



Peripheral Atmospheres:
A Native Bird Centre for the Manukau Harbour

Peripheral Atmospheres:

A Native Bird Centre for the Manukau Harbour

Andrew Benjamin Lowe
Student Identification: 1383827
Bachelor of Art and Design (Honours), Spatial Design
School of Art and Design, Spatial Design

Co-Supervisors: Carl Douglas & Sue Gallagher
January 2018

An exegesis submitted to Auckland University of Technology
in partial fulfilment of the requirements for the degree of
Master of Art & Design.

Abstract

Our peripheral experiences are an agency for the inter-personal. In this practice-led research, *light, movement, and textural surfaces* become crucial in peripheral engagement in producing an '*ecology of we*' (Baek, 2016, p. 72).

The project responds to an idea put forward by a collection of community groups for a Manukau Harbour Native Bird Centre in Ambury Regional Park, where people can view and come to understand the significant bird life and complex ecology of the region.

Disengaging from our surroundings diminishes our personal experience, our interpersonal engagements, and our empathy for the natural world. Peripheral experiences provide a means to anchor us in our surroundings, where we share our daily exercises with other subjects. There is no single measure of experience; rather we advance collectively and approach the world intersubjectively. This is not only limited to other humans. We share the vibrant ephemeral qualities of the world with other organisms and non-living things, in an ecology of we. This embeddedness, which Gernot Böhme and Peter Zumthor refer to as '*atmosphere*', is the orchestration of ephemeral effects. Sensory experiences of *light, movement, and textural surfaces* become crucial in this engagement. Peripheral experience is an agency, it acts on us.

The practice work has been strategised in two interlocking and overlapping stages: an installation entitled '*Microcosm*', and the design of the Manukau Harbour Native Bird Centre (MHNBC) itself.

Acknowledgements

To Carl Douglas and Sue Gallagher, for your supervision, support and encouragement throughout the year.

To Harriet Stockman, for your generosity and patience.

To Jewel Yan, Taewoo Kang and Kate Nalesu, for your unwavering support and optimistic studio culture.

To Frank Liu, for your generous time and support during examination installing.

To Sue Hedges and the Spatial Design department.

And to my family.

Contents

Abstract	V
Acknowledgements	VII
Contents	IX
List of Figures	XIII
Introduction	1
Chapter One: Research Contexts	
Godwits, the others, and I	7
The Peripheral	8
Atmosphere	12
‘ecology of we’	20
Chapter Two: Methods	
Making and breaking	29
Walking and Flying: Mobile Perspectives	32
Microcosm: Peripheral experiences of Manukau Harbour	44
Paths and Volumes: Modelling and Drawing	72
Particulate Surfaces: Material Narratives	92
Findings	118
Exhibition: Manukau Harbour Native Bird Centre	120
Appendices	152
References	168

Attestation of Authorship

I hereby declare that this submission is my own work and that, to the best of my knowledge and belief, it contains no material previously published or written by another person (except where explicitly defined in the acknowledgements), nor material which to a substantial extent has been submitted for the award of any other degree or diploma of a university or other institution of higher learning.

A handwritten signature in black ink, consisting of a stylized, cursive 'S' followed by a horizontal line and a small flourish.

signature

5 October 2017

date

List of Figures

- Figure 1. Lowe, Andrew. Walking and Flying: Mobile Perspectives – Panorama. 2017
- Figure 2. Lowe, Andrew. Walking and Flying: Mobile Perspectives – Lagoon. 2017
- Figure 3. Lowe, Andrew. Walking and Flying: Mobile Perspectives – Foreshore. 2017
- Figure 4. Lowe, Andrew. Walking and Flying: Mobile Perspectives – Diagram. 2017
- Figure 5. Lowe, Andrew. Walking and Flying: Mobile Perspectives – Foreshore. 2017
- Figure 6. Lowe, A. (2016). Host of Shadows: Slowness, wabi-sabi, and the tea ceremony. (Bachelor in Art & Design, Honours, Spatial Design Disseration), Auckland University of Technology.
- Figure 7. Lowe, Andrew. Walking and Flying: Mobile Perspectives – Mountain. 2017
- Figure 8. Lowe, Andrew. Walking and Flying: Mobile Perspectives – Foreshore. 2017
- Figure 9. Lowe, Andrew. Walking and Flying: Mobile Perspectives – Foreshore. 2017
- Figure 10. Lowe, Andrew. Walking and Flying: Mobile Perspectives – Lagoon. 2017

- Figure 11. Baek, J. (2015). The ecology of 'we' and ambient warmth: Richard Neutra's ecological architecture. *ARQ: Architectural Research Quarterly*, 19(4), 349-359. doi:10.1017/S135913551600004X
- Figure 12. Ha, T.-H. (2015). WE HUMANS. Inside the world's best kindergarten
- Figure 13. Ha, T.-H. (2015). WE HUMANS. Inside the world's best kindergarten
- Figure 14. Lowe, Andrew. Walking and Flying: Mobile Perspectives - Map. 2017
- Figure 15. Lowe, Andrew. Walking and Flying: Mobile Perspectives – Tempest. 2017
- Figure 16. Lowe, Andrew. Walking and Flying: Mobile Perspectives – Sunday stroll. 2017
- Figure 17. Lowe, Andrew. Walking and Flying: Mobile Perspectives – Mountain. 2017
- Figure 18. Lowe, Andrew. Walking and Flying: Mobile Perspectives – Bird panorama. 2017
- Figure 19. Lowe, Andrew. Walking and Flying: Mobile Perspectives – Flying. 2017
- Figure 20. Lowe, Andrew. Microcosm – Panorama. 2017
- Figure 21. Lowe, Andrew. Microcosm – Setup. 2017
- Figure 22. Lowe, Andrew. Microcosm – Setup. 2017
- Figure 23. Lowe, Andrew. Microcosm – Material. 2017
- Figure 24. Lowe, Andrew. Microcosm – Detail. 2017
- Figure 25. Lowe, Andrew. Microcosm – Lighting. 2017
- Figure 26. Lowe, Andrew. Microcosm – Cut. 2017
- Figure 27. Lowe, Andrew. Microcosm – Cut. 2017
- Figure 28. Lowe, Andrew. Microcosm – Movement. 2017
- Figure 29. Lowe, Andrew. Microcosm – Movement. 2017
- Figure 30. Lowe, Andrew. Microcosm – Light shaft. 2017
- Figure 31. Lowe, Andrew. Microcosm – Camber. 2017
- Figure 32. Lowe, Andrew. Microcosm – Light and water. 2017
- Figure 33. Lowe, Andrew. Microcosm – Camber light. 2017
- Figure 34. Lowe, Andrew. Microcosm – Underneath. 2017
- Figure 35. Lowe, Andrew. Microcosm – Happy accident. 2017
- Figure 36. Lowe, Andrew. Microcosm – Light surface texture. 2017
- Figure 37. Lowe, Andrew. Microcosm – Diffused camber. 2017

- Figure 38. Lowe, Andrew. Microcosm – Materialise light. 2017
- Figure 39. Lowe, Andrew. Microcosm – Wandering. 2017
- Figure 40. Lowe, Andrew. Modelling and Drawing – Studio space. 2017
- Figure 41. Lowe, Andrew. Modelling and Drawing – Auckland CBD - Manukau Harbour. 2017
- Figure 42. Lowe, Andrew. Modelling and Drawing – Plantation and wildlife. 2017
- Figure 43. Lowe, Andrew. Modelling and Drawing – Climate, wind, and tides. 2017
- Figure 44. Lowe, Andrew. Modelling and Drawing – Site specific. 2017
- Figure 45. Wasit Natural Reserve Visitor Centre / X Architects (22 Mar 2016). Retrieved from <http://www.archdaily.com/784055/wasit-natural-reserve-visitor-centre-x-architects>
- Figure 46. Wasit Natural Reserve Visitor Centre / X Architects (22 Mar 2016). Retrieved from <http://www.archdaily.com/784055/wasit-natural-reserve-visitor-centre-x-architects>
- Figure 47. Zumthor, P. (2016). Allmannajuvet Zinc Mine Museum. Retrieved from http://www.archdaily.com/796345/allmannajuvet-zinc-mine-museum-peter-zumthor?ad_medium=widget&ad_name=navigation-next
- Figure 48. Zumthor, P. (2016). Allmannajuvet Zinc Mine Museum. Retrieved from http://www.archdaily.com/796345/allmannajuvet-zinc-mine-museum-peter-zumthor?ad_medium=widget&ad_name=navigation-next
- Figure 49. Lowe, Andrew. Modelling and Drawing – Sawtooth roof. 2017
- Figure 50. Lowe, Andrew. Modelling and Drawing – Light and lines. 2017
- Figure 51. Lowe, Andrew. Modelling and Drawing – Cross volumes 1. 2017
- Figure 52. Lowe, Andrew. Modelling and Drawing – Cross volumes 2. 2017
- Figure 53. Formanfantasma. (2012). Craftica. Retrieved from <http://www.formafantasma.com/craftica>
- Figure 54. Formanfantasma. (2014). De Natura Fossilium. Retrieved from <http://www.formafantasma.com/de-natura-fossilium>
- Figure 55. Lowe, Andrew. Material Narrative – Tile 1. 2017

- Figure 56. Lowe, Andrew. Material Narrative – Tile 2. 2017
- Figure 57. Lowe, Andrew. Material Narrative – Tile 3. 2017
- Figure 58. Lowe, Andrew. Material Narrative – Tile 4. 2017
- Figure 59. Lowe, Andrew. Material Narrative – Tile 5. 2017
- Figure 60. Lowe, Andrew. Material Narrative – Tile 6. 2017
- Figure 61. Lowe, Andrew. Material Narrative – Accidental shell glaze. 2017
- Figure 62. Lowe, Andrew. Material Narrative – Shell glazing. 2017
- Figure 63. Lowe, Andrew. Material Narrative – Glaze 1. 2017
- Figure 64. Lowe, Andrew. Material Narrative – Glaze 2. 2017
- Figure 65. Lowe, Andrew. Material Narrative – Glaze 3. 2017
- Figure 66. Lowe, Andrew. Material Narrative – Glaze 4. 2017
- Figure 67. Lowe, Andrew. Material Narrative – Tile Light 1. 2017
- Figure 68. Lowe, Andrew. Material Narrative – Tile Light 2. 2017
- Figure 69. Lowe, Andrew. Material Narrative – Tile Light 3. 2017
- Figure 70. Lowe, Andrew. Material Narrative – Lime mortar. 2017
- Figure 71. Lowe, Andrew. Material Narrative – Gloss and matte. 2017
- Figure 72. Lowe, Andrew. Material Narrative – Shell-lime mortar. 2017
- Figure 73. Lowe, Andrew. Material Narrative – Slaking lime. 2017
- Figure 74. Lowe, Andrew. Material Narrative – Material Exhibition. 2017
- Figure 75. Lowe, Andrew. Material Narrative – Experiments. 2017
- Figure 76. Lowe, Andrew. Material Narrative – Irregular edge. 2017
- Figure 77. Lowe, Andrew. Material Narrative – GRC slab. 2017
- Figure 78. Lowe, Andrew. Material Narrative – Negative Detail. 2017
- Figure 79. Lowe, Andrew. Exhibition setup – Cluster setup
- Figure 80. Lowe, Andrew. Exhibition setup – Part 1: Microcosm
- Figure 81. Lowe, Andrew. Exhibition setup – Part 2: MHNBC
- Figure 82. Lowe, Andrew. Exhibition setup – Objects, models, proposal
- Figure 83. Lowe, Andrew. Exhibition setup – CNC model, sawtooth 'education'

- Figure 84. Lowe, Andrew. Exhibition setup – CNC model, sawtooth ‘exhibition’
- Figure 85. Lowe, Andrew. MHNBC – Roof plan
- Figure 86. Lowe, Andrew. MHNBC – First floor plan
- Figure 87. Lowe, Andrew. MHNBC – Ground floor plan
- Figure 88. Lowe, Andrew. MHNBC – Arrival visualisation
- Figure 89. Lowe, Andrew. MHNBC – Roof tile details
- Figure 90. Lowe, Andrew. MHNBC – Ramp visualisation
- Figure 91. Lowe, Andrew. MHNBC – Interior exhibition visualisation
- Figure 92. Lowe, Andrew. MHNBC – Exhibition cabinet detail
- Figure 93. Lowe, Andrew. MHNBC – Clay kit detail



Introduction

A quiet Sunday afternoon, the sun draws close to the peak. An unplanned walk on the foreshore coastal track. Autumn light, not too cold nor too hot but just right. Warmth radiating off the concrete track. Signs of relief from trees arching over cambers and inland foliage. Pleasantly green leaves, alive and vibrant. Speckles of light, barely falling through dense foliage, paving spotlights in the shadow, lightly prickling my skin with warmth. Perhaps not so quiet, locals walking past. I nod, they respond – I'm not so alone after all. Activity in the foliage, out of sight, but I can hear them. The chirp of birds and insects – rhythmic, dense but also distinct. We are sharing the same tree away from the sun. The experiences that make up my encounter with this place are not directly attended to but are peripheral, on the edges of my perception. (Figure 2)

How can *peripheral experiences* become an agency for the *inter-personal*? In particular, how might *light, movement* and *textural surfaces* be crucial in producing an 'ecology of we'? (Baek, 2016, p. 72).

This research project questions our tendency to disengage from our peripheral experiences. Peripheral experiences include movement caught from the corners of our central vision, or subtle changes in ground conditions unconsciously altering our body's movement in space. The periphery extends beyond our vision but to sensory experiences that sit adjacent to it. We only fully comprehend our surrounding as our existence is immersed by unstable states of atmospheric conditions. Peripheral experiences shape our world from the fringes. They are experienced but not necessarily noticed.

Figure 2. An Autumn afternoon along Māngere Lagoon, warm light filtered through foliage.

It is crucial to consider the 'things around' as the constructs of the world rather than our focused, cognitive consciousness of particular objects. From our awareness of space, we begin to acknowledge and act upon the presence of being within these shared conditions amongst other humans, organisms, and things. The peripheral breaks from cognitive focus, pointing towards the inter-personal intersections of things around us. Through the periphery, we engage the world collectively.

The research turns on a proposal for a new Manukau Harbour Native Bird Centre in conjunction with the Manukau Harbour Restoration Society (MHRS), Birds NZ, local iwi, and industry partners. For many years, Manukau Harbour has been a dumping ground polluted by wastewater discharged, affecting local wildlife and harbour community. Over the years of Auckland expansion, Watercare has managed water services throughout Auckland; their facilities have improved over the years, but pollution damage persists. Manukau Harbour is home to a diverse land and marine eco-system specifically focusing on the illusive godwit / kuaka. Godwits are migratory birds flying between New Zealand and Alaska. Thus, the implementation of a native bird centre performs as more than just a platform to view birds, creating a sense of community, care, and empathy with the harbour.

As of May 2017, MHRS are currently seeking funds and are in negotiation with Auckland Council. My site explorations and design proposal will be presented to them as a concept for the native bird centre to use in mobilising the project.

Embedded in the native bird centre project is a philosophy for sustainable design that will become an exemplary movement for a better relationship with nature. The project adopts spatial theorist Jin Baek's critique of our current sustainable design practices which emphasises on the reduction of material and energy consumption but lose traction with inter-personal factors of designed environments. In Baek's argument, nature is not a separate entity which we encounter but rather the present surrounding condition which we are inhabiting of which he calls an *ecology of we* (2016).

The research project is carried out in two phases: an immersive installation that diagrams and prototypes atmosphere, and the development of this experience into the MHNBC.

'Microcosm: Peripheral experiences of Manukau Harbour' is a 1:1 scale installation, iterating from a previous work investigating ingression and discrepancy of atmosphere thematised around Japanese tea ceremony (Lowe, 2016). This phase engages peripheral experiences from a series of walks around the Manukau Harbour, extrapolating conditions of light and movement thematising the installation.

This engagement is particularly interested in atmospheric conditions of light, movement, and textural surfaces as the few peripheral experiences that engage with our surroundings. *Light* reveals and conceals space – a blanket of shadow to animating and composing movement of space. *Movement* of the self or other things captured within the corners of our eyes suggests life inviting participation with the atmosphere. *Textural surfaces* unconsciously engage in our daily effects to movement and pause in space, emphasising material narrative.

In Chapter one, I discuss my critical contexts, particular ideas of peripheral experience, atmosphere, and the *ecology of we*. In Chapter two, I discuss my methodology and working methods through the two phases of the project. In “Findings”, I draw these threads together and point towards the work to be exhibited in November 2017.

Thus, my research follows up on subjective ideas of atmosphere, extending them to become a shared experience than a singular encounter in space. I hope to share a developing practice that takes atmosphere as a core spatial concern, practising empathic processes that consider things animate and inanimate. Instead of ‘I feel ...’, the atmosphere that embodies other subject, things, and organisms become ‘we feel ...’ – thus, we begin to empathise with others encouraging an inter-personal assembly (Baek, 2016).

Godwits, the others, and I

Introduction

Space is never encountered as a solo subject but rather as a shared condition amongst others. As a designer, it is important to consider the collectively shared conditions of space in establishing empathic processes. In this chapter, I outline three key research contexts. I first examine peripheral vision through the anatomy of the human eye as a reference to compare with the godwit's peripheral experiences. The periphery is a multi-sensory experience rather than just peripheral vision; second, the multi-sensory experience is theorised as atmosphere. Here, I follow up on ideas of atmosphere from a previous project, *Host of Shadows* (Lowe, 2016), resituating atmosphere as an inter-subjective encounter and specifically discussing the effects of light, movement, and textural surface engagement with the periphery. Lastly, the ecology of we is explicated as an inter-personal exchange emerging from our shared inter-subjective encounter. I embody empathic processes – this project is viewed through I, godwits, we, and others. (Figure 3)



Figure 3. A dotterel warning sign in front of the shell bank, indicating the presence of dotterels and others.

The Peripheral

Juhani Pallasmaa, in *Eyes of the Skin: Architecture and the senses*, writes,

“The very essence of the lived experience is moulded by hapticity imagery and unfocused peripheral vision. Focused vision confronts us with the world whereas peripheral vision envelops us in the flesh of the world.” (Pallasmaa, 2012, p. 10).

“Peripheral unfocused vision” forms the enveloping world around us (Pallasmaa, 2012, p. 10). Our world is not only made up of the things we focus on, claims Pallasmaa, but also the things around us that we barely register. It does not confront us – it envelops us. Physiologically, our unconscious peripheral vision has always been influencing our conscious experience.

The retina of an eyeball contains multiple neural layers filtering light. The photoreceptor layer contains receptors of rods and cones, managing two major light information. Rods are sensitive to light intensities while cones work better in brighter condition with a better perception of colour. The uneven distribution rods and cones on the surface of the retina vary our perception of colour and light values in different regions of our vision. (Hitzel, 2015). Our periphery is affected by this distribution of cone and rods. The periphery reads light intensity better than our focused attention, the fovea range. The fovea range (the central region of the retina) contain more cones, thus sends more colour information to our visual senses. While outside the fovea range, rods are more prominent and sensitive to the subtleties of light intensity. Thus, the periphery is better at picking up movement or dimmer lighting conditions. (Hitzel, 2015)A simple test is conducted by staring into the night sky where our focused area tends to be darker. The non-fovea range better responds to faint glows in the night sky due to more rods; *light*, in general, is more sensitive in our peripheral sensory domain.

In comparison, birds – particularly godwits – have wider periphery views than humans due to the position of their eyes, see Figure 4. These conditions set a larger field of vision of their surroundings, which becomes key to their migration technique to fly in formation (Fernandez-Juricic, 2010). The godwits are known to fly in V-shape formation for the formation’s aerodynamic capabilities making efficient use of their energy reserve (Battley, 2014). In this formation, they maintain sight of each other so that they can stay as a flock during their eight-day journey across the planet.

The importance of peripheral vision to the godwits suggests a significant part of my design strategy – one that emphasises peripheral experience as a means of being subconsciously aware of subtleties of the environment and empathising with the other organisms which we share. Rather than just watching birds, the native bird centre should help us acknowledge our shared place. It is not merely for looking at or attending to – it is for looking with, co-habiting. (Figure 5)

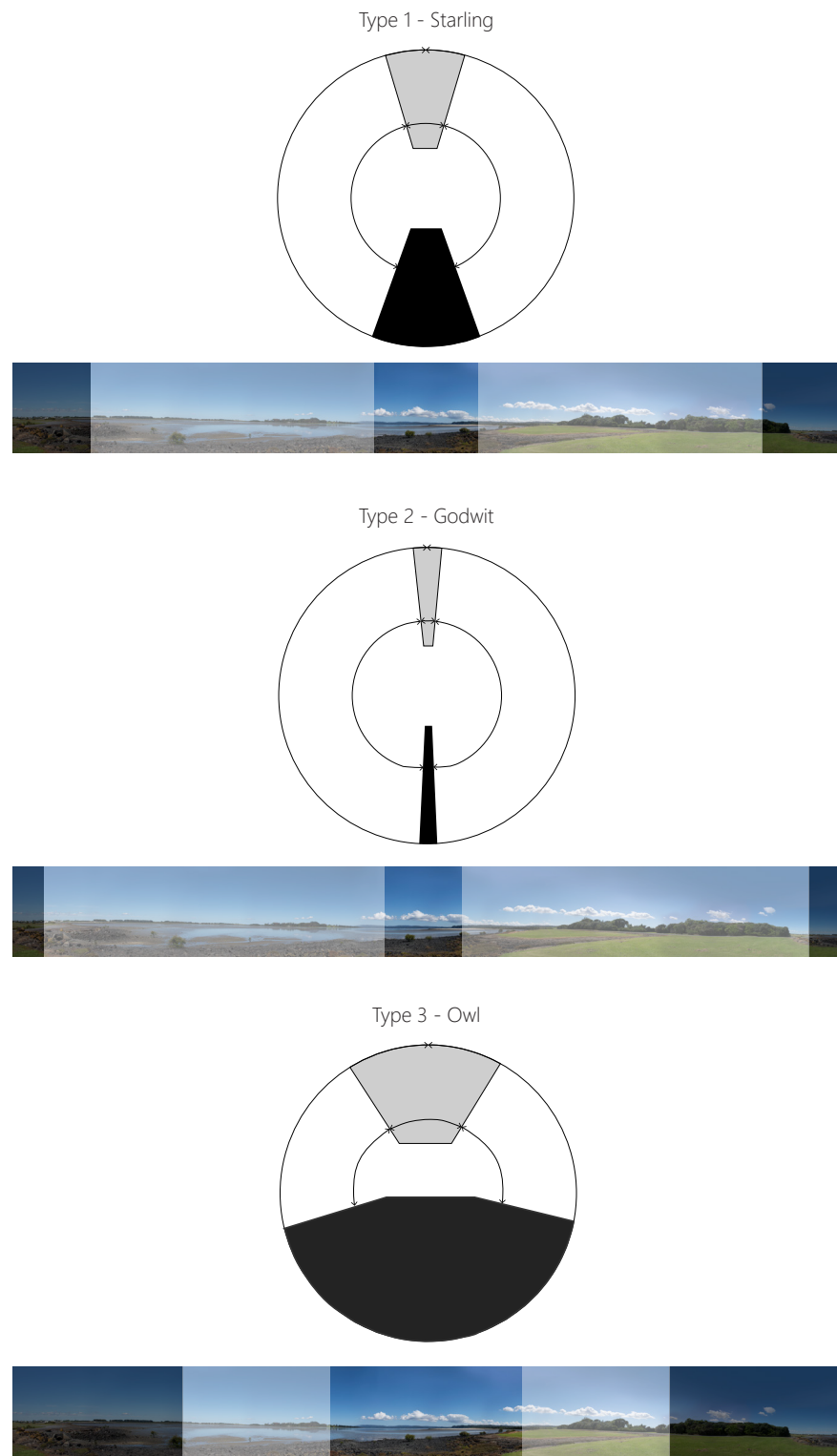

Figure 4. Diagrams comparing three types of birds peripheral vision, redrawn from National Science Foundation - Bird vision explained.



Figure 5. Gravel pathway with dense foliage creeping in harbouring vibrant wildlife.

Atmosphere

As I walked through dense foliage along the Manukau Harbour's coastline, the lives of birds and insects resonated with the air around me. Unaware of the ambient sound that surrounds the edge of our periphery, the vibrant microcosm of life lives inside the dense foliage. Speckles of sunlight penetrate through the foliage onto our skin which "reads the texture, weight, density and temperature" (Pallasmaa, 2012, p. 56). Like our vision able to see the text of shadows, our haptic senses are also able to pick up on the texture of light and warmth through the foliage. This entails the world around us is embodied through unconscious multi-sensory experiences.

Peripheral experiences expand beyond the scope of visual experiences. The world around us is more than just visual and passive; we constantly negotiate with our surroundings in finding equilibrium. "Our bodies and movements are in constant interaction with the environment; the world and the self inform and redefine each other constantly." (2012, p. 40). This holistic, embodied experience is what Pallasmaa calls haptic experience, which has also been theorised as atmosphere.

In a previous project, *Host of Shadows* (a reinterpretation of the traditional Japanese tea house), (Lowe, 2016) I used atmospheric ideas from philosopher Gernot Böhme and architect Peter Zumthor to focus on subjective experiences. I considered atmospheric conditions – particularly *light* and *heat* – from the perspective of a single human subject. (Figure 6) In this project, I want to address atmospheres as shared and empathised between subjects. Here, I resituate the notion of atmosphere as multiple encounters as gestures to an empathic process of designing.



Figure 6. 'Host of Shadow' (2016), a tea ceremony held in a cavernous space with penetrating sunlight through slits of newspapers.

Böhme writes that atmosphere is “that which mediates the objective qualities of an environment with bodily-sensual states of a person in this environment” (2014, p. 92). It is the “in-between (Zwischen): between objective conditions and subjective states, between object and subject.” (2014, p. 92). The term connotes climatic phenomena; Böhme notes how a “looming thunderstorm brings with it an agitated mood.” (2014, p. 93). Atmosphere is also perceived as drifting feelings or “spaces pregnant with a mood” (2014, p. 93). It links internal subjective experience with external conditions, situating atmosphere as a shared encounter. Atmosphere becomes discernable through ‘*ingression* and *discrepancy*’ (2014, p. 93). *Ingression* is the initial wafting of atmosphere; (Böhme, 2014) peripheral experiences of warmth and light unconsciously impact our first impression of atmosphere. *Discrepancy* is when we become aware of atmosphere through a change in conditions (Böhme, 2014).

Zumthor recounts his personal experience of atmosphere, writing:

“It is Maundy Thursday 2003. Here I am. Sitting in the sun. A grand arcade – long, tall, beautiful in the sunlight. The square offers me a panorama – the facades of houses, the church, the monuments. Behind me is the wall of the café. Just the right number of people. A flower market. Sunlight. Eleven o’clock. The opposite side of the square in the shade, pleasantly blue. Wonderful range of noises: conversations nearby, footsteps on the square, on stone, birds, a gentle murmuring from the crowd, no cars, no engine sounds, occasional noises from a building site.” (2006, p. 15)

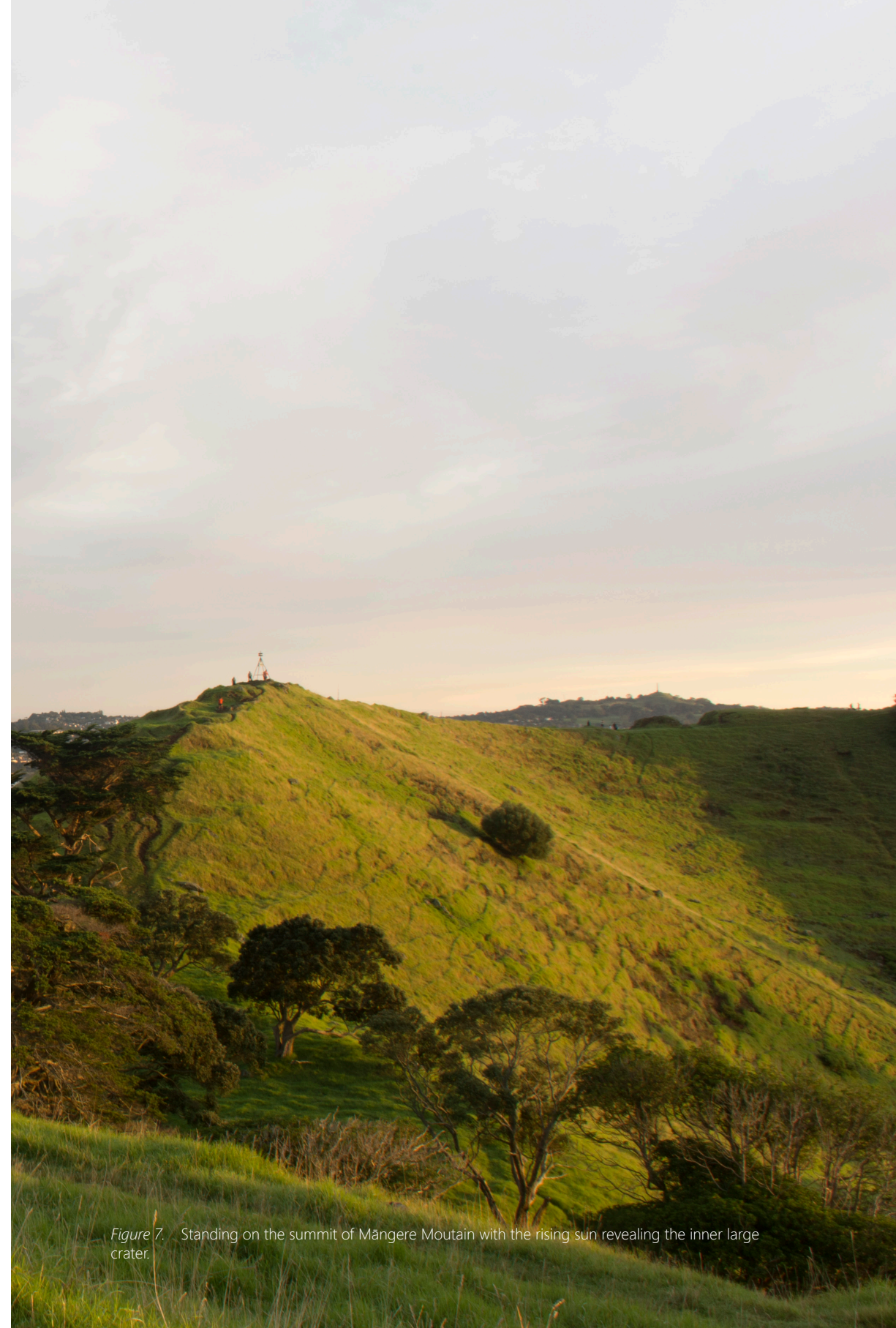

Figure 7. Standing on the summit of Māngere Mountain with the rising sun revealing the inner large crater.

He recounts the multiple experiences surrounding everyone in the plaza from “air, noises, sound, colours, material presences, textures, forms too” (2006, p. 17). Thus, atmosphere is shared as an inter-subjective encounter.

Zumthor describes light as worldly matter. This became apparent to him as he started to notice the way light fell upon surfaces, illuminating new life to even dull spaces (2006). (Figure 7) Zumthor approaches light like carving into a solid material – shadow becomes a mass and light is the substance that seeps through, slitting the material. This could be thought as the bright streaks of light seeping through tree foliage or a passing cloud revealing the emanating glow of curtains in the living room, revitalising mundane spaces. Light interplays with movement:

“It was incredibly important for us to induce a sense of freedom of movement, a milieu for strolling, a mood that had less to do with directing people than seducing them.” (2006, p. 43)

Movement at the corner of our vision dilutes the tension between interior and exterior – physical planes in the background are homogenised by movement. The periphery can evoke containment with any physical compression; movement captured at the corner of our vision suggests something beyond our peripheral capacity. Imagine a forest of tawa trees, tall and linear. This sets up visual planes or boundaries to our horizontal horizon. *Movement* diffuses the in-between space, animating void space by diluting static surfaces to take part with the *movement*. We lose the static surfaces from attention directed towards the movement.

Textural surface conjoins *weight, sound, light, and temperature*. It can exaggerate and complement – think of how black steel poles against white woven fabric exaggerate the lightness of the fabric and complement the structural integrity of steel. Textural surface tunes and builds vibrancy of atmosphere; surfaces can reflect, absorb, diffract, contract, and expand manifesting material narrative. (Figure 8)

Light, movement, and textural surfaces have become key registers for my design – particularly in their subtleties and variations. States of *ingression* and *discrepancy* are induced through these means, orchestrating moods in space. As externalised conditions or spatialised moods, atmosphere is a shared, inter-personal phenomena. (Figure 9)



Figure 8. Varying textural layers of natural foliage reveal and shade heat of sunlight.



Figure 9. Foreshore fence – a loose feather caught onto the rough wood grains.

'ecology of we'

In his *"Architecture as the Ethics of Climate"* (2016), Jin Baek describes atmosphere as not merely subjective but as *inter-subjective*. He derives his idea of atmosphere as an "ecology of we" (p. 72) from the Japanese philosophical notion *fudo*, climate, as described by philosopher Tetsuro Watsuji. The *ecology of we* redirects our attention from how I feel to how we feel. He begins:

"There are spaces first. Then, space emerges as a concept abstracted from our experiences of space. Likewise, before there is nature, there is *fudo*, or climate. Nature as such, or pure nature, is an abstraction." (2016, p. 17)

Nature should not be regarded as a separate entity to humans. When the wind changes, our first experience is not a scientific comprehension of hot or cool air but as "a mountain blast or the cold, dry wind that sweeps through Tokyo at the end of the winter" (2016, p. 17). In our phenomenological encounter, there are inseparable bonds between humans and nature. Similarly, such atmospheric experiences place us on a plane in which multiple subjects participate, emerging as an inter-subjective encounter. Because we are pre-exposed to the atmosphere before engaging with it, participants are adjoined by the same conditions. In this participatory atmosphere, 'I's become a part of an ecology of we, detaching from their singular subjectivity. (Figure 10)

Watsuji adopts Martin Heidegger's concept of *ex-sistere*: "*ex-sistere* is to be amongst other 'I's" (Baek, 2016, p. 21). Baek quotes Heidegger,

"When 'I' go toward the door of the lecture hall, 'I' am already there, and 'I' could not go to it at all if 'I' were not such that 'I' am there. 'I' am never here only, as this encapsulated body; rather, 'I' am there, that is, 'I' already pervade the space of the room, and only thus can 'I' go through it." (2016, p. 21)

Other 'I's inhabit the atmosphere, producing a mirror of reflection for self-discovery. Watsuji exemplifies this point with his experiences of coldness:

"When we feel cold, we ourselves are already in the coldness of the outside air. [...] While the relationship between one and coldness is that of intentionality, the relationship between different 'I's in the coldness is that of mutual compassion." (Baek, 2016, p. 21)

The mutually shared condition of atmosphere between others where 'we' emerge from the collective mutual experiences – 'we' always exist before the presence of 'I'. The world is not just the personal encounter – it is constantly being shared as inter-subjective encounters.

Baek exemplifies this with a scenario of a father and son walking about during the summer season in Japan. Both father and son are exposed to the heat. This overheating prompts the father to find shade – reinforcing the mutuality of experience – as the father empathises with his son's overheating condition. Verandas are arching off buildings cast shades of relief from the sun. His intention in that atmosphere turns towards the shadow. Empathy unfolds into action – he invites his son into the shade with him simply by his action, without saying a word. (Baek, 2016)



Baek makes a reading of Richard Neutra's houses in these atmospheric terms, claiming he achieves the *ecology of we* in his Corona School, Los Angeles, by using architectural elements in tuning atmospheric conditions of coldness and hotness, promoting empathic moves from the dichotomous relationship. The dichotomy between cold and hot encourages the joining of 'we' in the migratory movement between the shaded interior and sunny exterior activity patio. Rather than a subjective view of the world around us, ecology is shared as a setting for the t (Figure 11)

Takaharu Tezuka's recent kindergarten in Tokyo might also be seen as the setting for an *ecology of we* to emerge. The centre is shaped ovate. Tezuka explains: "We designed the school as a circle, with a kind of endless circulation." (Ha, 2015) While the architectural form does denote a radial centre suggesting a microcosmic gesture of internalising an ecology, it could be better understood as a gesture towards a shared atmosphere. Undulated surfaces of mud mounds and changes of tactility on the wooden rooftop encourage children to run and make noise. Occupants are constantly aware of movement in their peripheral vision. Laughter reverberates across the central courtyard. The shared atmosphere is produced through sound and movement, common sensations of peripheral engagement, and *inter-personal* actions of joining microcosmic interaction between children. (Figure 12,13)

In both these examples – and I intend in my design for the MHNBC – peripheral experience takes on *inter-personal* agency. That is, peripheral experience acts on us in a shared way. In the commonality of being adjoined by common atmospheric sensation, we transcend the feeling of empathy – 'I feel' for others become 'we' feel, adjoined by the atmosphere in our everyday encounters. (Baek, 2016)

Figure 10. They shared the same shade – I empathised with them in seeking relief from the heat.



Figure 11. Richard Neutra, Corona School, 1935, children empathise through their shared climate.



Figure 12. Tezuka Architects, Katsuhisa Kida, 2007, the ovulate form encourages continuous activity critical to the generation of kindergarten atmosphere.



Figure 13. Tezuka Architects, Katsuhisa Kida, 2007, activity to reverberate throughout the school as an ecology of we.

Making and breaking

Introduction

This project employs a phenomenological methodology, with emphasis on atmosphere as a shared peripheral experience. That is, I have been concerned with atmospheric experience first and then sought the materials, spatial arrangement, and form of the Bird Centre in light of this. Accordingly, the project was structured in two phases: first, a 1:1 atmospheric installation entitled *Microcosm: Peripheral experiences of Manukau Harbour* and second, the design for the Manukau Harbour Native Bird Centre or MHNBC, carried out through scaled models, drawings, and full-scale prototyping of materials.

'*Microcosm*' translates my peripheral experiences walking beside the Manukau Harbour as grounds to experiment modes of atmosphere embedded within our periphery. This installation puts emphasis on *light* and *movement* as two prominent elements that were embodied walking through foliage and open spaces along the harbour.

It was necessary to shift into a representational mode for the MHNBC proposal, using drawings and models. However, I continued to engage with the 1:1 mode of experimentation, with an emphasis on *textural surfaces* as strategies in materialising narratives. I alternated between an embodied experience of prototyping peripheral experiences and the representational mode of experiences as an opportunity to design and anticipate spatial and atmospheric arrangements.

In this chapter, I first explore phenomenologically two mobile perspectives – *walking and flying*, embedded methodologically in my two phases. I then reflect on the construction and thinking of atmospheric qualities through the *Microcosm* installation, considering how these qualities have been pursued in the shift to models and drawings. Finally, I share accidental findings that have morphed and shaped the project. These could be thought as unknown forces within the project that picked up speed and revealed itself as something else.



Figure 14. Walking series – peripheral engagements through these tracks taken between Mangere Mountain and Mangere Lagoon.

Walking and Flying: Mobile Perspectives

Walking

As a method, *walking* acts as a gesture to engage with peripheral experiences. While in motion, our body is constantly finding equilibrium internally and externally to the atmosphere. Similarly, Richard Long uses *walking* as a generator for his works. He walks through a vast range of terrains, leaving marks on the land as methods remnant to his embodiment of the unique features of the site. Long first establishes an idea then maps in detail to avoid topographical restrictions. (O'Rourke, 2013) Whereas his artworks only show remnants of his walks, fronting the unique land features he embodied. I draw on a similar approach in embodying peripheral experiences of light and movement captured in a series of photographs as a means to recount on the unconscious peripheral experiences. Preliminary site visits were planned as a series of walks here called *Tempest*, *Sunday Stroll*, and *Morning Māngere Mountain*. (Figure 14)

Tempest, 12th March 2017

1135, reports of flooding throughout Auckland dispersing throughout the coming week – a fleeting moment of high water season. Thrashing waves in the unusably filled Māngere Lagoon, waves dampened by eroding edges of the lagoon filled with clay and dirt. Constant rainfall is tapping on the roof of my raincoat poncho. (Figure 15) Impairing gusts of wind limits my vision through frosted fogged glasses as I am forced to face the ground, guided solely by the edges of my peripheral vision barely making the lagoon on my left.

1203, a slight camber to the right reveals the expansive harbour stretching further than my visual capacity. Surprised by locals also walking the foreshore track with their tightly flexed umbrellas. Ecology of we is suggested in the form of a slight glance of acknowledgment to the present shared state of the atmosphere.



Figure 15. Tempest – looking out into the hazy lagoon silhouetting an outline of the opposite end of the lagoon.

Sunday stroll, 19th March 2017

Starkly different with the tempest subsiding midweek revealing the sun for the first time. This week I invited my parents along – a comfortable walk for both them and me.

1055, Autumn light falls softly over midday while intensities still feeling like summer. I passed on simple directions to my parents, “walk down the path, turn right with the lagoon on your left, continue walking till you find the coastline and keep that to your left”. Peripherally briefed over screeching insects, silent shores, and the odd bird call under a canopy of foliage. (Figure 16)

1115, walking through speckled light pushing through dense foliage from overgrown trees beside the walking track. The heat has started to take effect; relief from the sun is welcomed by my parents and me. Shifts in air pressure from the concrete radiating heat penetrating into the stillness of shade. Unconsciously, all these fluctuations build the world around us; without recalling the heat, sound, and shadows we are only presented with a visual memory of the concrete track.

Morning Māngere Mountain, 01st April 2017

0634, slowly warming up by the sunrise while shivering all over standing on the submit. Faint glow reveals the reflective horizon. Facing out into the west coast, sunrise projecting light into the infinite horizon. Comfort from the emanating glow wrapping around my rear periphery light animates the harbour and reveals a unique perspective from my elevated horizon line. In elevating the body onto the mountain, looking over the harbour detaches my ground experiences to an aerial view over site. (Figure 17)



Figure 16. Sunday stroll – covered by arching canopies of foliage enveloping the periphery with shadow, white noise, and heat.



Walking adopts a personal encounter to site, while introducing my parents into the walks detached my perspective to empathise them and others. It also enabled me to feel the terrain and experience the site in motion. Walking along Māngere Lagoon under a canopy of tree branches, space was compressed by casted shadows. This is represented in a 360-degree stitched panoramic photograph as a means to capture the singular moment, including the wider periphery. Panoramic stitching becomes a crucial tool for the rest of the project in representing the periphery. Peripheral vision is not the only peripheral experience – it envelops us.

Figure 17. Looking out into the Manukau Harbour from Māngere Moutain – light reveals the reflective water patches across the mud flats exaggerating the verticle periphery.

Flying – Detaching from the subjective

Flying detaches my subjective views of Manukau to consider the godwit's experiences. Godwits are migratory birds; they migrate to southern hemisphere islands to avoid northern winters. Godwits leap into the horizon with no map or guide towards New Zealand, and their only lead is to orientate and fly southwards – an endurance-challenging flight of about 11,000 km in 8-9 days. (Woodley, 2013) The project adopts these gestures of orientation from the godwits. While in the air, godwits keep the rising and setting sun within their peripheral to fly southbound; my experience on ground draws attention to my orientation on shadow lines. Being aware of these greater forces in smaller wildlife enacts a more holistic approach.

The godwits experience a lowered horizon datum of the world. The shifts exaggerate the vertical periphery, reminding us the periphery is not just the horizontal – the difference in vertical periphery encourages the attention to things above. (Figure 18)

Whereas, the flight experience is interpreted in the form of photographic panoramas manipulated from two ground panoramas: foreshore and Māngere Mountain. (Figure 19) Joining the sky as the common ground of a bird's flight, the view is an exaggerated two-sidedness due to the position of their eyes. Both stitched panorama emphasizes the view of the sky from its disproportional sky-to-land ratio. This engages our vertical periphery as a reminder to our ever-changing horizon orientation. Vertical periphery is later carried out into a 1:1 installation redefining approaches to exploring a project through photography techniques.

Walking frames the horizontalness of our experiences, whereas flying disorientates and reminds us the vertical periphery is just as important. Also, the shifting of our horizon views light differently that are further tested in a 1:1 test installation. This manifested particularly through my panoramic explorations and manipulations.



Figure 18. Phone, two-part panorama stitched, panning across from a crouched position focuses on the tree line, setting the ground to our side periphery.



Figure 19. Vertical -two ground panorama joined by the common sky.

Microcosm: Peripheral experiences of Manukau Harbour

Microcosm was constructed through suspension of newsprints generating mass like Zumthor's approach to constructing shadows. (Figure 20) First, through the mass of shadows as a mass of material cutting away for *light* to seep through, this method controls the light levels of space. I worked with primary materials like steel wires, paper clips, and masking tape. (Figures 21, 22, 23, 24, 25) The simplicity of materials allowed the contingencies of the installation to affect it – allowing failures to become interesting findings.

The suspension of paper is a translation, an interpretation to the density of foliage experienced around Manukau Harbour. I first established one rule when carving through the layers of newsprint to mimic the body's arm radius. (Figures 26, 27) The body responds to the proportionality of space amplifying the effects of peripheral engagement. (Figures 28, 29) Consciously, I was recounting my experience walking through the site, carving each sheet to replicate and interpret my site encounters into a built environment. Detaching myself from the embodied experiences, I placed myself above the installation, viewing from a different scale. This considered the installation like an architectural model, reshaping my approaches of carving paths and the tension between interior and exterior emerging out from the camber, see Figures 30, 31.

All this was documented through the lens of a camera. A camera is a reoccurring tool to documenting these ephemeral experiences, but the camera also challenges the engagement of space in the framed view. Reflecting on certain methods in photographing, the lowering of the body is reminiscent of a godwit's view of the world – further realising the world below the suspension of paper. (Figure 32) The lowered body shifts the horizon datum, picking up reflectivity of the floor and textures created by offcuts. (Figures 33, 34, 35) Thus, the camera could be considered more than a tool with which we document a project,

as a way to reconstruct the installation. The limitations of the frame embody another perspective on the world.

This spatial prototype can be seen as an installation in its own right, but it was also a step on the way to the design of the Bird Centre, establishing a spatial and atmospheric language of orientations, paths, textural effects, and light. (Figures 36, 37, 38, 39)



Figure 20. Revealing of the exterior microcosmic space contrasted to the interior path.

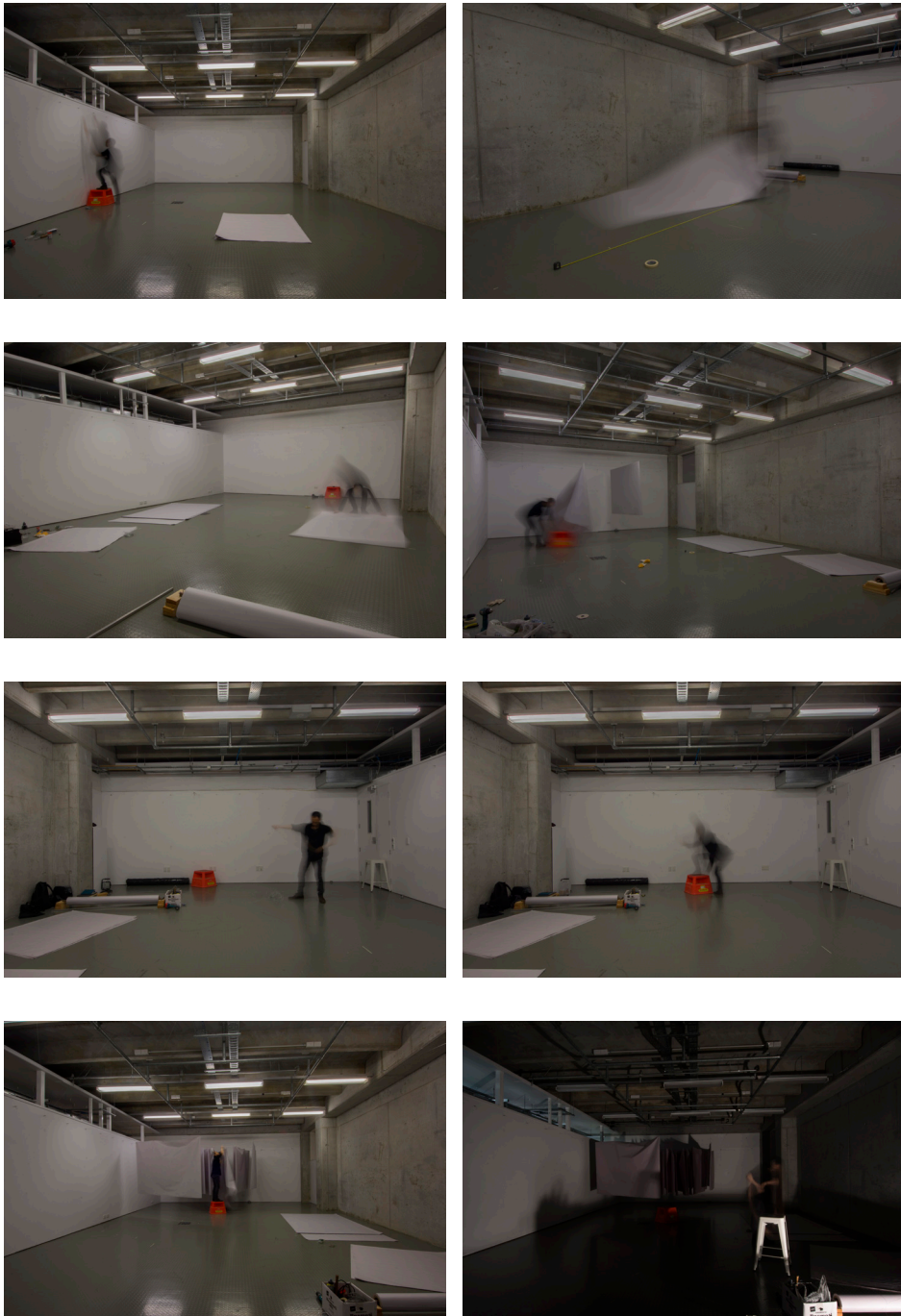

Figure 21. Series of stills from a stop-motion film of preparing *microcosm*.

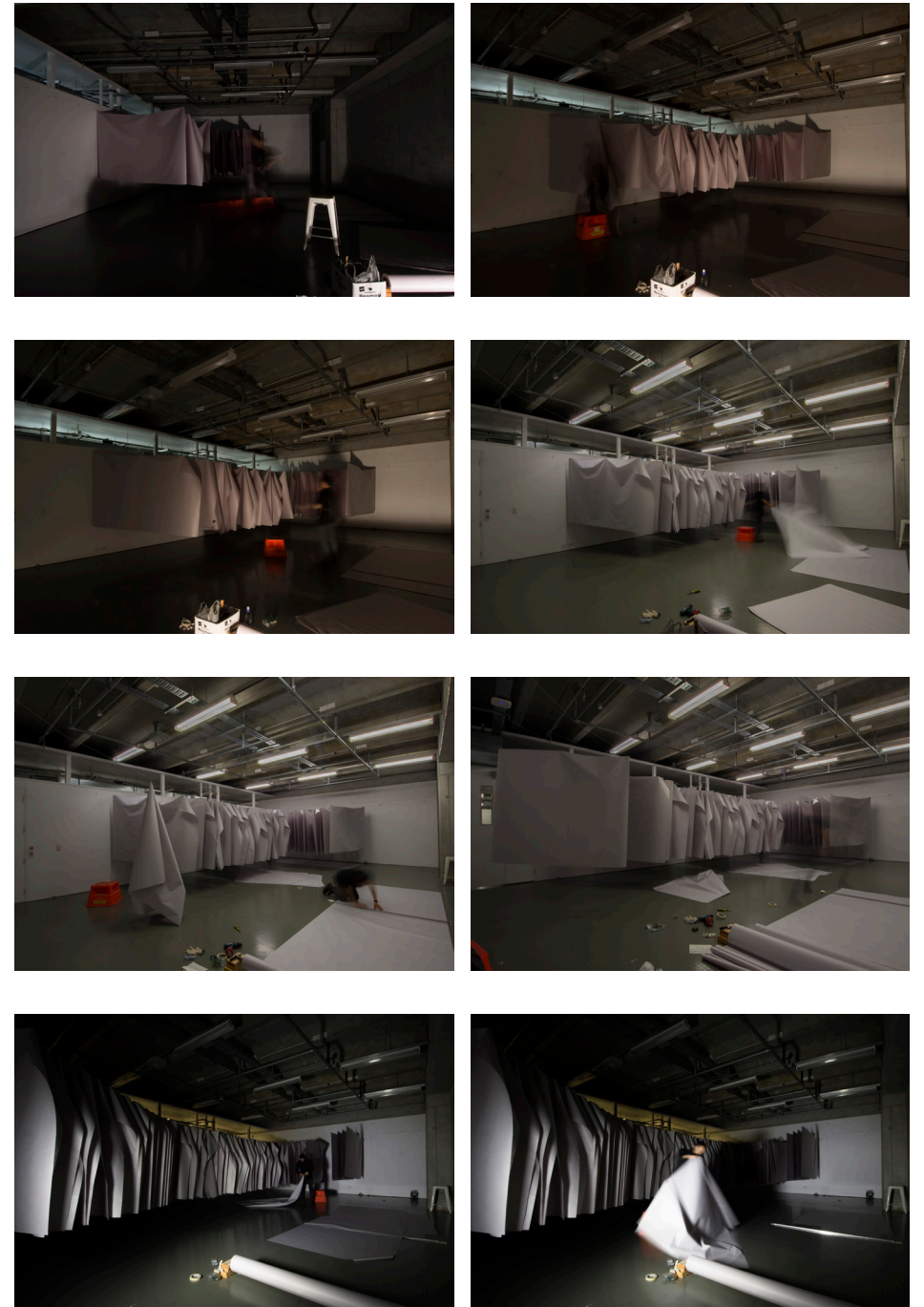

Figure 22. Stop-motion stills of cutting, hanging, and carving.

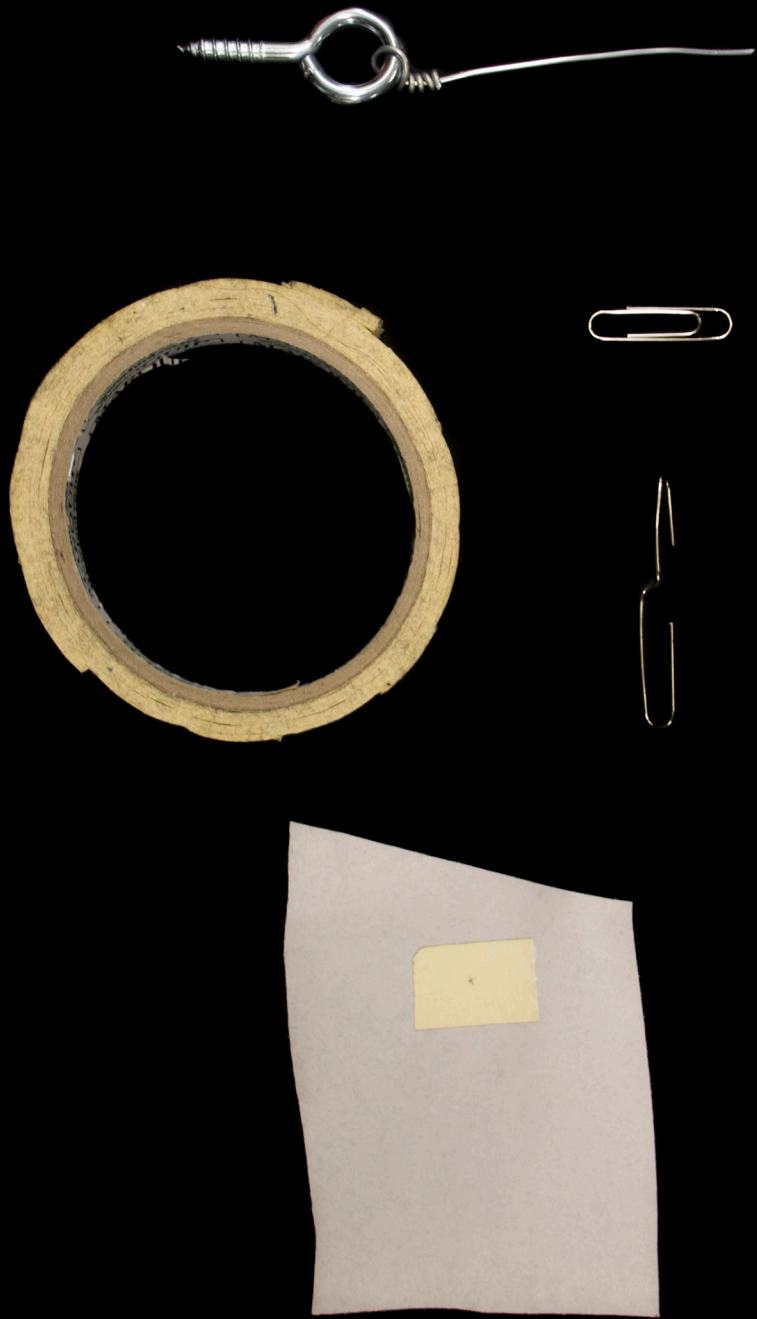

Figure 23. Core ingredients to *microcosm* - screw eye, masking tape, paper clip, and newsprint.

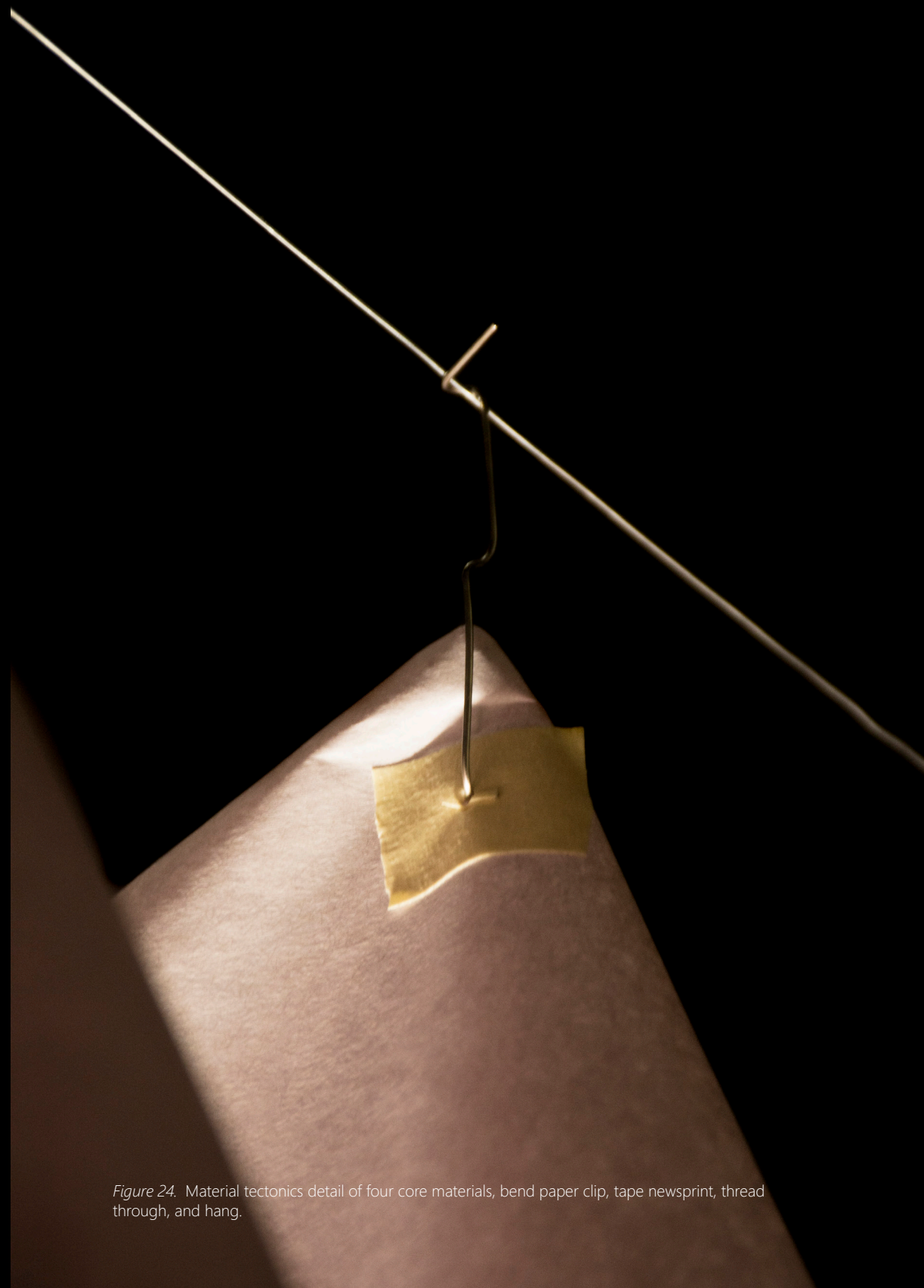

Figure 24. Material tectonics detail of four core materials, bend paper clip, tape newsprint, thread through, and hang.

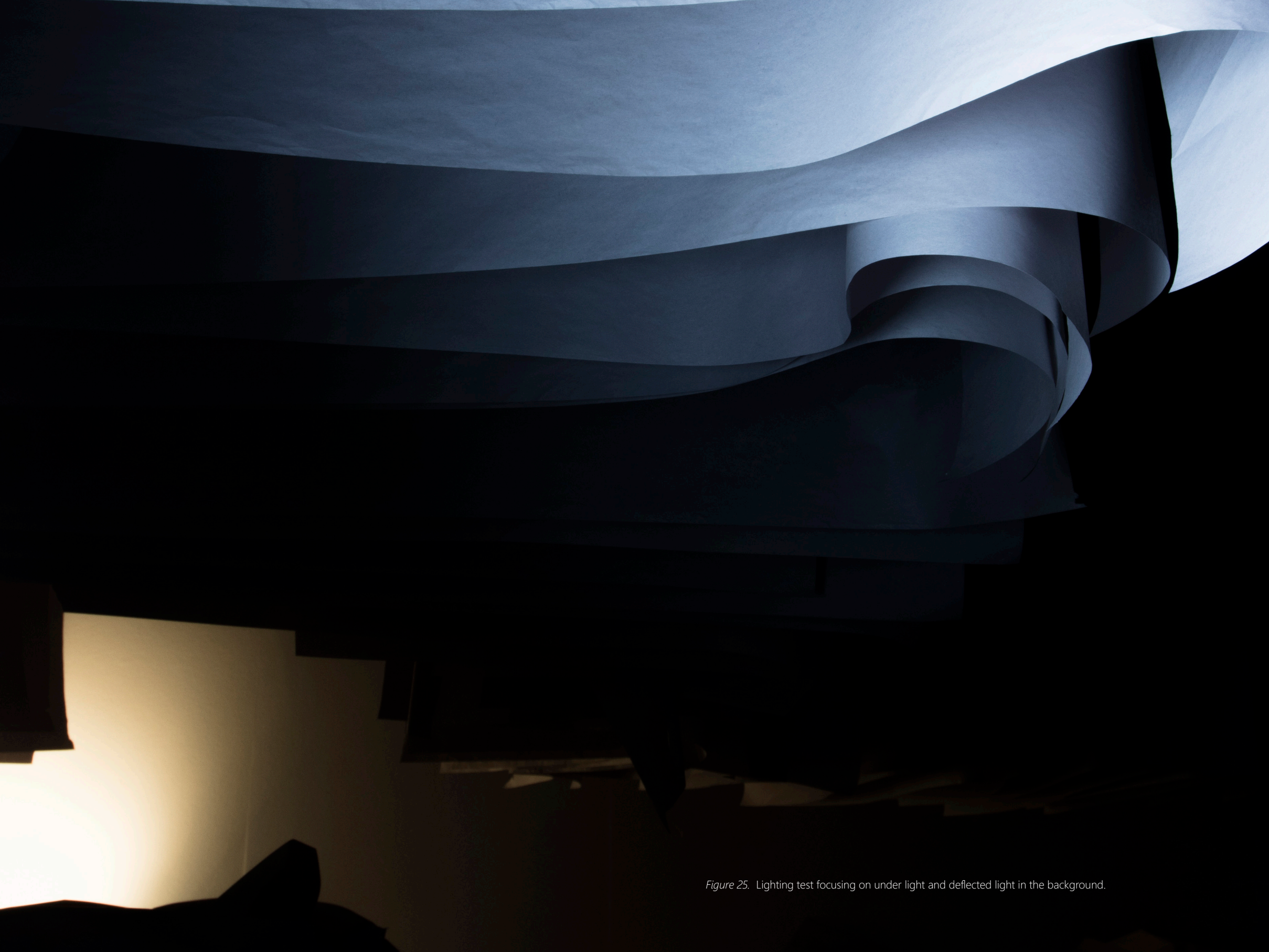

Figure 25. Lighting test focusing on under light and deflected light in the background.



Figure 26. Upon entering *microcosm*, a wall of newsprint pauses any further movement.



Figure 27. Clearing and carving a wandering path gaining access to the exterior.



Figure 28. Careful steps are taken influenced by the crunching newspaper.



Figure 29. Losing balance from the disorienting haptic experience, uses the wall to recalibrate balance.



Figure 30. Shafts of light reminiscent to tree line framing the clear skies.



Figure 31. Around corners with lowered cambers – curiosity strikes and amplifies the soft deflected warm flood light.



Figure 32. Naturally deflected light off white walls gives the soft, pervasive glow conjoined with the tactility of the vinyl floor and water.



Figure 33. Exaggerated carving tests the difference between warm flood lights and cool led lights caught on varying depth of newsprint.



Figure 34. The lowered body exaggerates the light caught upon the roof of the carved space.



Figure 35. Unexpected folds from the edge of newsprint – happy accident.



Figure 36. Standing perpendicular to the light source exaggerates the natural folds and texture of the material.



Figure 37. Negative detail between newsprint exaggerated by diffused camber light.



Figure 38. Layers of newsprint materialise the how light travels along surfaces.



Figure 39. Light draws movement through space, ambiguity and curiosity of corner lighting invites the milieu for wandering.



Figure 40. Workspace – working across mediums of rough drawings, modelling station, and digital modelling.

Paths and volumes: Modelling and Drawing

The transition from an embodied experiential testing space to representations – models and drawings – took me to relational scales beyond the body. The adoption of an iterative drawing and modelling process intersects the qualitative findings of microcosm with the pragmatic programming of MHNBC. (Figure 40) The intersection is concerned particularly with the programmatic planning of volumes, and with journeys to and from the centre. Working from the outline brief provided (see Appendix A), I established six main programme areas: exhibition, café, function, classroom, office, and services. Each of these needed to be articulated as an ecologically shared atmosphere through light, movement, and textural surface. The aim is to shape peripheral experiences rather than to make a formal or visual statement.

Drawing Scales and Paths

Drawing on scales beyond the body orients us to site. (Figures 41, 42) It is important for MHNBC to connect to the locality of the site. As our peripheral experiences suggest, we share the world with vibrant ephemera and other organisms. I considered sun orientation, prevailing south-westerly winds, and existing features around – particularly Māngere mountain. (Figure 43) These orientation axes are important to consider, as the atmosphere is not solely built on the immediate relationship of body to space. Orientating the entry of the exhibition area in relation to the mountain draws a connection between land and water from the interior volume. The entry of the exhibition area is also facing east to receive the sunrise when walking out towards the foreshore, while visitors experience the afternoon sunset against their backs when walking towards the mountain. Setting orientation axes in relation to the sun draws attention to the progression of time and provides a basis for differentiating programmes by lighting conditions. (Figure 44) The sawtooth roof form, usually used to ensure even light in industrial spaces, is here

turned to produce variable sun penetration. The classroom, office studio, and function rooms are set to north axis orientation for the sun rising and setting views.

The Wasit Natural Reserve Visitor Centre by X Architects (2016) helped me to think through this microcosmic gesture. Architecturally, the centre considers the existing topography, reducing visual impact by continuing the datum roof line with existing hills which setup homogenisation of architecture mass and microcosms formed between hills. Within the two microcosmic spaces of bird habitats, a central exhibition space runs along the site, partitioning two micro eco-systems, see Figures 45, 46. The perspectival space and one-sided exposure amplify the peripheral experiences received – simple lines can gesture effective microcosmic spaces, dramatically amplifying contrast of peripheral spaces.

As I drew paths, I recalled my experience of walking around Manukau Harbour, conjoining my embodied walking experiences to the lines of the drawings. An experience is not solely of one setting in a built environment but also drawn through the in-between space, the foreshore, and the journey back. The spaces are experienced in motion. A central path marked with white stone and ceramics passes through the exhibition space, between two small hills, and down to the foreshore with its white shell banks; it includes moments of cambered space and changes of level. This creates microcosms in the interior and encourages visitors to engage with things in their periphery.

Map and plan drawings tend to view site as static moments indexed to the age of the aerial photographs being traced (in this case 2004). Site conditions are constantly morphing, however, which prompted a move into modelling.



Figure 43. Mapping orientation to climate phenomena of sun, wind, and water level projection. Marked walks give reference to embodied experiences and photographs taken.

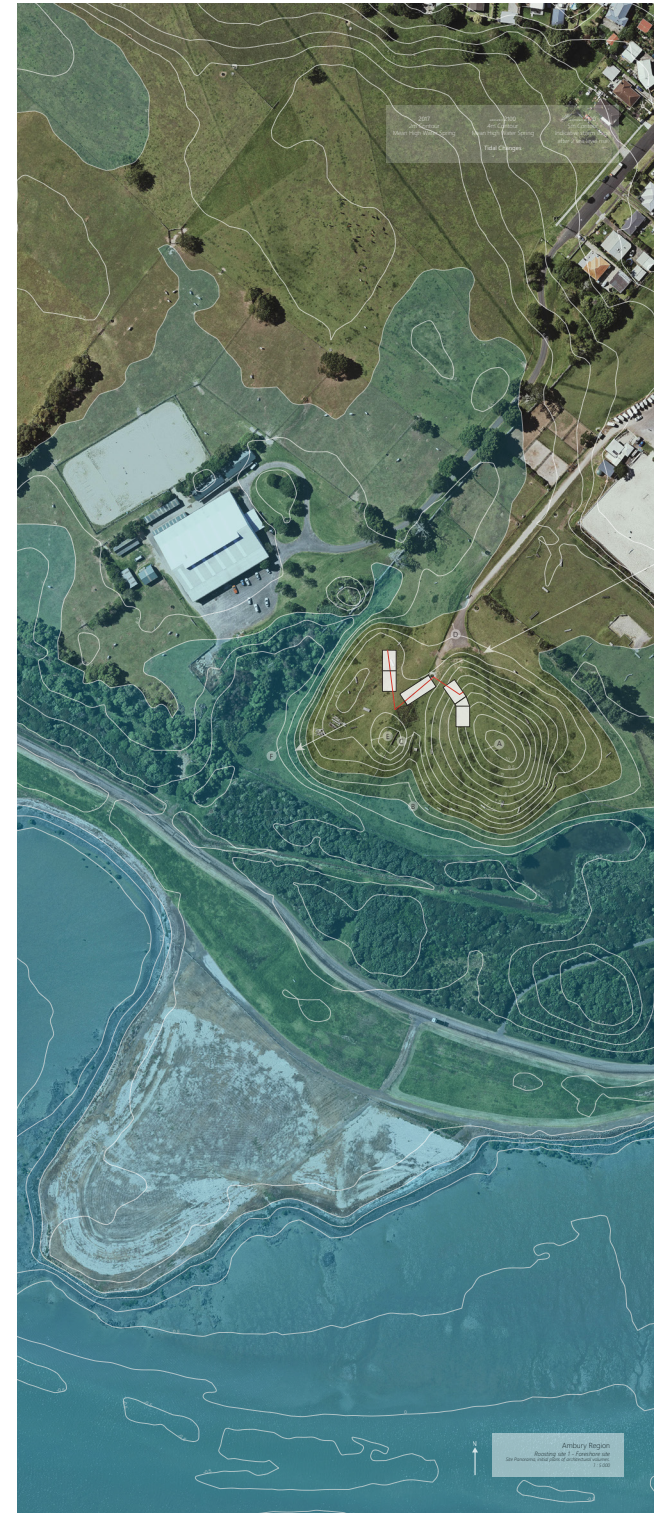

Figure 44. Early conceptual planning of volumes orientating to surrounding significant features, beginning to set up views about land topography.



Figure 45. X Architect, Wasit Natural Reserve Visitor Centre, 2016, draws simple lines demarcating two micro eco-systems.



Figure 46. X Architect, Wasit Natural Reserve Visitor Centre, 2016, full window glazing with exhibition along the linear perspectival space pointing exhibiting material into the roosting areas.

Modelling Atmosphere – roofs and volumes

I built a model at 1:50 scale, an ideal scale to bring together architecture details, volumes of space, and the behaviour of light. The modelling process asks two related questions: first, what is the relationship between the interior volumes and the site? And second, what kind of atmospheric quality is enacted by the site conditions? The in-between spaces of volume create microcosmic spaces set in the periphery of the building facades. This was further emphasised by the fissure on the ground plane shifting the body in establishing a demarcation of the exterior public space formed between volumes. The volumes were initially modelled as free elements so I could move them around to explore the possibilities of their in-between conditions.

I drew on Zumthor's Zinc Mine Museum, sited along a tourist highway in Alamanna Canyon in Sauda, Norway, which seeks to honour the history of the zinc mine by using atmospheric gestures. (Zumthor, 2016) He used simple architectural forms of exposed structural wooden framings encapsulating an enclosed volume with mono-pitched roofs. (Figures 47) Importantly, he focused on the interior atmosphere as a means to elevate artefacts in the open museum. A small exhibition shelf with carefully controlled natural light flooding in gives a transcendental effect to the artefact, see Figure 48. Zumthor orchestrates these atmospheric gestures as a means to connect and invite the audience towards the next pavilion. The modelling process adopts this thinking of the interior atmosphere to orchestrated flow and curiosity throughout the site. The contrast between the dark interior and exterior mediated by movement and flow through volumes.

Building a model was beneficial to knowing what works atmospherically than relying on renders to articulate lighting. Simple tests – like changing the opacity of light-diffusing materials – were used to test volumetric effects. I used simple materials: masking tape, card, and paper. This meant disregarding the actuality of proposed materials, but studies of volumetric space were the emphasis here. (Figures 49, 50, 51, 52)



Figure 47. Peter Zumthor, Allmannajuvet Zinc Mine Museum, 2016, three of the four buildings placed along the walking track with the incentives of finding the next building from the atmospheric experience

on the interior.



Figure 48. Peter Zumthor, Allmannajuvet Zinc Mine Museum, 2016, natural lighting detail is illuminating the artefacts contrasted with the dark surrounding.

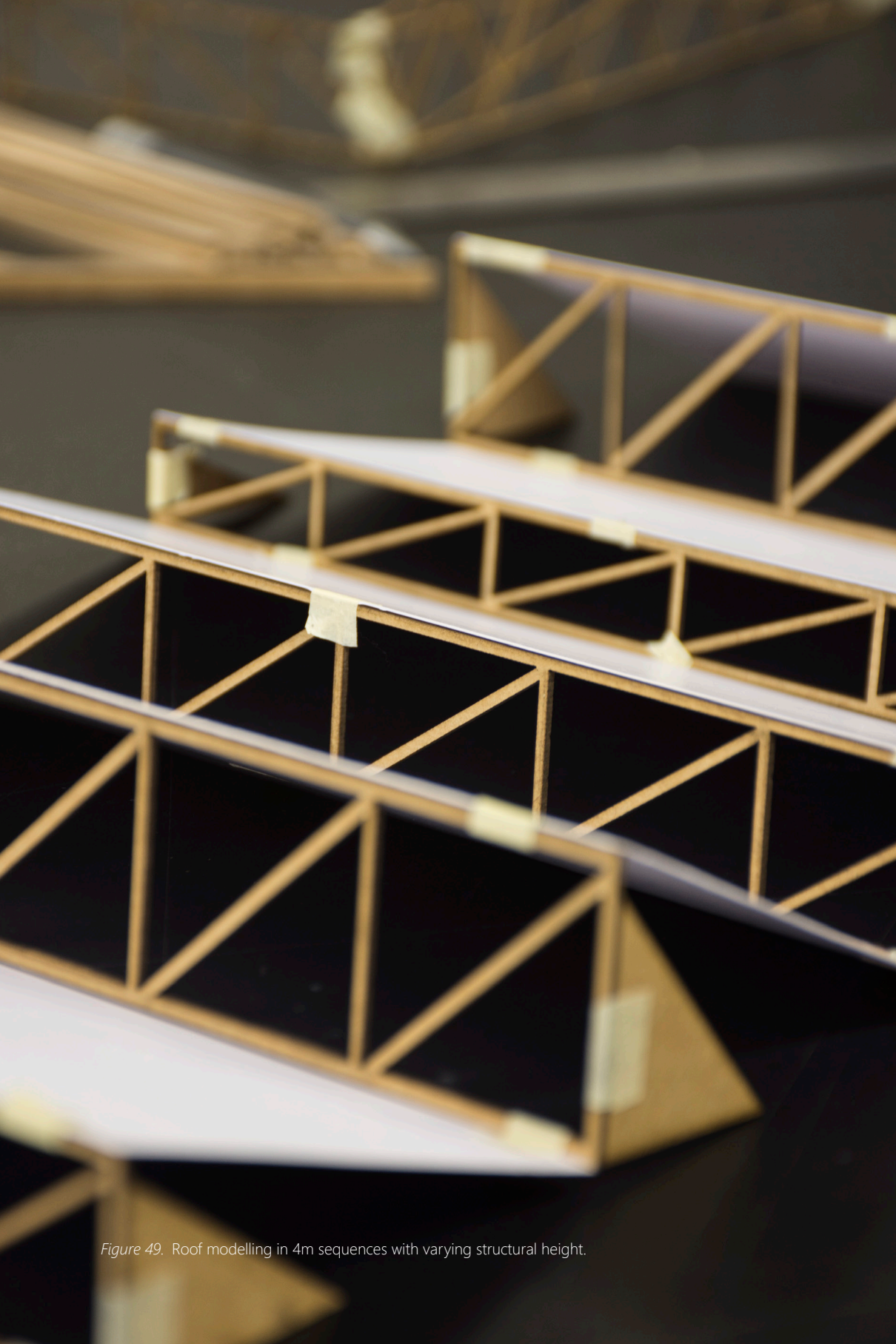

Figure 49. Roof modelling in 4m sequences with varying structural height.



Figure 50. The lighting test is investigating shadows cast from the linear lines of glazing and structure.



Figure 51. Conceptual model view from café space through volumes builds complex arrangement of vertical lines in space like the dense foliage around Manukau Harbour.



Figure 52. Sawtooth roof exposes northern axes, gaining access to Māngere Mountain looking back.

Particulate Surfaces: Material Narratives

I did not stop my 1:1 material experiments, but I shifted them into experiments with material narratives, working with ceramic tiles. I saw these as a continuation of the full-scale installation work of *Microcosm*. The decision to use shells as a core material of investigation unfolds from an adaptive reuse practice and intersects us with the godwits' experiences of the site, particularly the banks of oyster shells on which they roost. Interpreting and transforming their experience of their roosting site, the 'we' emerges on this plane of material surface.

Material Narrative – Formafantasma

My approach recalls Formafantasma, an Italian design duo stretching material limits and inventing unconventional methods. They work with themes of adaptive reuse, in the sense of critical sustainability adjoining tradition and local. Their experimental practice ranges from "fish skin, cow bladders, animal blood and even lava." (Figure 53) (Hobson, 2013). In *Craftica* (2012), they used fish skins from a company in Iceland that are being discarded in the food industry. Investigating "leathercraft in conversation with other hand-worked, natural materials", they developed fine-grained fish-skin textiles. (Formafantasma, 2012) As a studio practice, it continues to be extremely experimental to work first-hand with the material. In *De Natura Fossilium* (2014) they experimented with lava, creating a mesh out of basalt volcanic rock. By rethinking different states of material and adapting different techniques, they refined the materiality of rock into a fine mesh, an unexpected materiality. (Figure 54)



Figure 53. Formafantasma, *Craftica*, 2012, fish skin as discarded material, repurposed as hot water bottles.



Figure 54. Formafantasma, De Natura Fossilium, 2014, scoria rocks melted back into the state of lava and prepared into a thread for embroidery work.

Material origins and adaptive reuse

I explore the use of invasive Pacific Oyster shells and Watercare's implementation of shell bank roosting sites for shorebirds. This mode of adaptive reuse, as a practice, sets a tone for the project to be considerate to material consumption. On a contextual term, the shells implemented along the foreshore are homes to migratory shorebirds that roost over northern winters. Here, we consider the perspective of the birds, reinterpreting the vast whiteness and tactility of the shell banks. To do this, the shells are crushed, pulverised, fired, mixed, slaked, and reused. This material exploration is an atmospheric generator and a symbolic reminder to shared place.

I experimented with using shell in conjunction with ceramics. There were three basic processes: tile-making, glazing, and slaking. Accidents and unexpected results were significant design generators. Tile-making first focuses on the surface articulation of sequenced patterns and tiling patterns as a means to shift movement and light relief through patterned surfaces. (Figures 55, 56, 57, 58, 59, 60) The patterns were created by the repetitive imprinting onto a 3mm slab-rolled body of clay. There was no preference on which crushed piece of shell used. Here, I intentionally let the experiment lead itself allowing the processes of tile-making, the materiality of clay and shells to narrate tidal rhythms. Working by hand introduced irregularities and variations in the shells amplified through repetition.

Next, I cured the surface through glazing, adding a glass-like layer on top of the bisque-fired clay. Glazing creates a range of surfaces treatment varying from mirror-like reflectivity to matte diffusion; the glaze is a way to articulate light. Experiments revealed unexpected and unique properties of seashells. (Figures 61, 62) I introduced pulverised calcium carbonate to the glaze recipe, hypothesising it would act as a whitener or make the glaze opaque. (Figures 63, 64, 65, 66) I also

tried simply stacking shells on top of clay fired at roughly 1100 degrees Celsius. The hidden salt content embedded in the shells due to their porosity leached out and was absorbed into the chemical structure of the clay during firing, producing a natural gloss and shine on the tiles. This process is like salt or soda firing kilns where the ceramist throws salt in the middle of glaze-firing, changing the glaze outcome. The chemical reaction lifts and draws out the natural silica content embedded within the clay. While shell glazing is not a controllable parameter, through this method, I allowed contingency into the regularity of the tile-making processes. (Figures 67, 68, 69)

Lastly, I tried using the seashells to make lime cement. Limestone is harvested, burned, and slaked to make lime, a core ingredient of cement. Shells are traditionally used to make lime-based mortar or bricks for construction. A church near Māngere Bridge also uses this lime-based construction technique, see Figures 70, 71, 72, 73. Learning and trying the slaking process has changed my perspective on materials like concrete. It is not only specifying a material to be used in a proposal, but also the source and processes involved in making cement that can bear the material narrative of the project. The designer does not simply apply materials – it is an embodied process participating in the material tectonics.

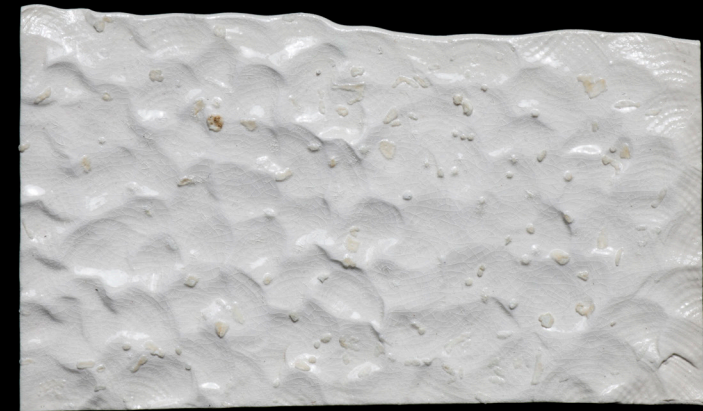

Figure 55. Slightly agitated – focused on transferring shell patterns like the surface of Māngere Lagoon, the slightest ripple surface.

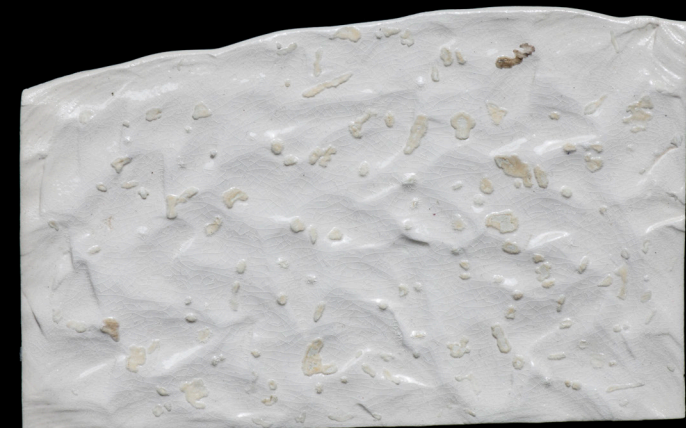

Figure 56. Random rifts – lightly imprinting patterns onto the surface while rotating and overlapping.



Figure 57. Lightly pressed and smoothed by tugging the clay a little.



Figure 59. Shells washed back and forth with the tides – crushed shells rolled along clay surface, some stuck whilst some gave way.

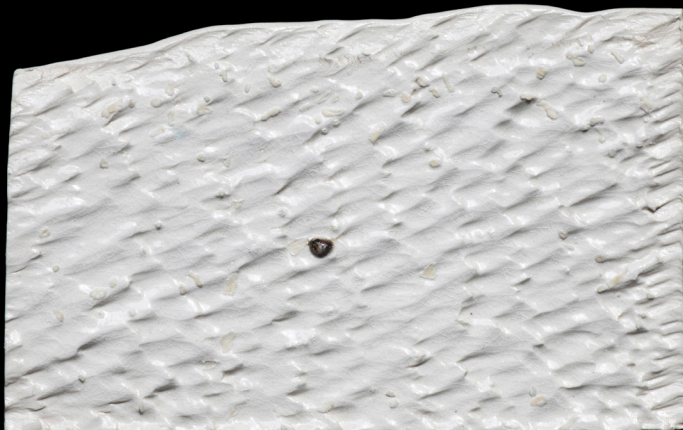

Figure 58. Punctured in – edgy piece forced into clay for larger negative detail.

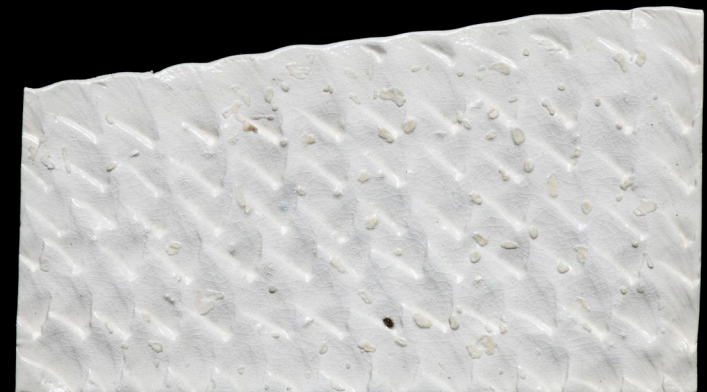

Figure 60. Sharp-edged shell lightly pressed into the clay – random but only slightly skewed.

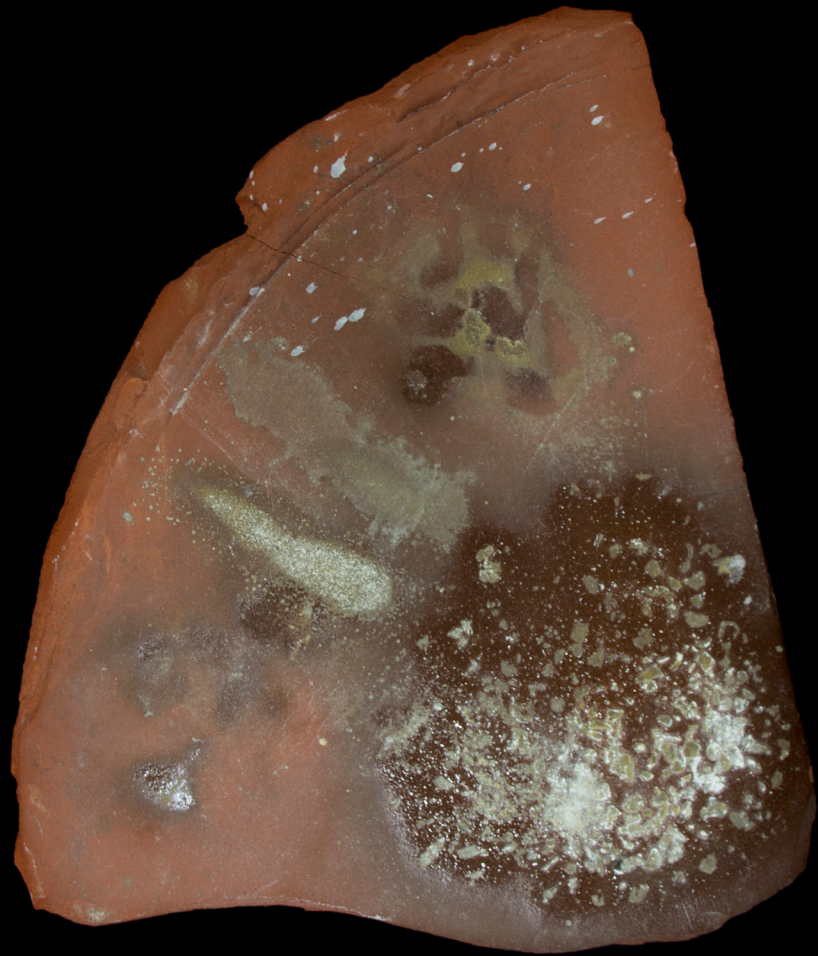

Figure 61. First accidental shell glazing on spare terracotta kiln shelf.



Figure 62. Shell glazing, using hidden salt contents from seashells. Clay + Shells + 1100 degrees Celsius heat.

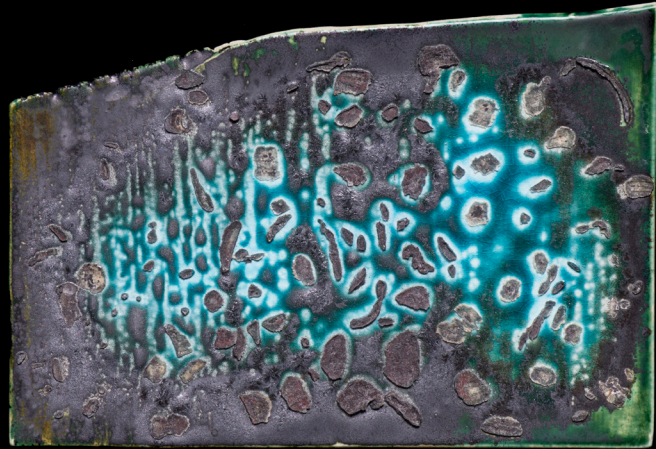

Figure 63. Glaze: Copper Oxide + Calcium carbonate + Gloss glaze base + Shells stacked

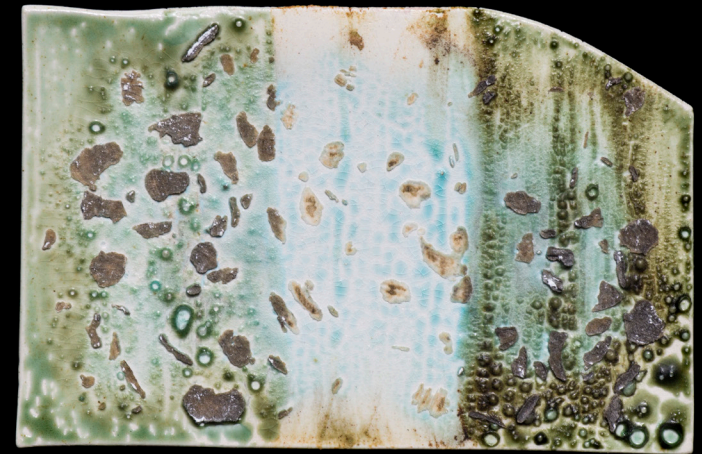

Figure 65. Glaze: Copper Oxide + Iron Oxide + Calcium carbonate + Gloss glaze base + Shells stacked



Figure 64. Glaze: a mixed of everything + Shells stacked

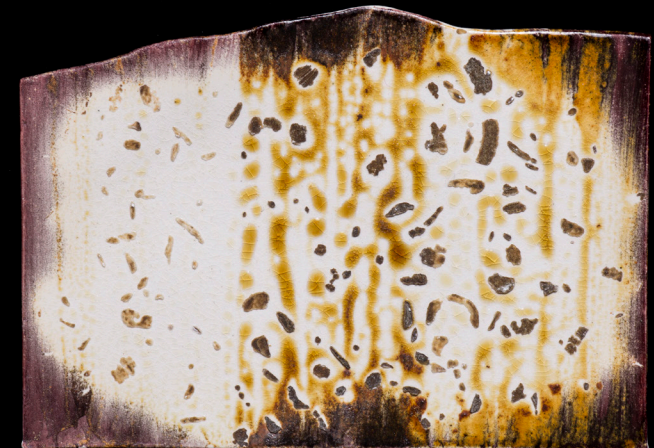

Figure 66. Glaze: Iron Oxide + Calcium carbonate + Gloss glaze base + Shells stacked



Figure 67. Exaggerating the cavity with top-down lighting for dramatic shadows.



Figure 68. Top-down lighting in animating the smoother subtle pattern.



Figure 69. Clay + Crushed scoria + Shell glaze - coloured glaze from the iron contents.



Figure 70. Lime based mortar with sand stuck onto clay.



Figure 71. Clay hardens with lime, half glazing the brick from greenware achieving a gloss and matte contrast – Clay + Finely crushed scoria + Half-gloss glaze



Figure 72. Lime-shell based mortar – Crushed shells + Slaked lime



Figure 73. Stills from video of batch slaking quicklime from fired shells.

These particulate surfaces are a crucial part of my material palette. I exhibited them in *Material*, a show of work by postgraduate Spatial Design students, see Figure 74. To frame the material palette, I welded a steel frame display device to test an idea for furnishing the exhibition spaces of the MHNBC. The frame has surfaces at varied heights, setting datum lines at 1.2m, 0.8m, and 0.3m; I also built a low stool. (Figures 75, 76) These varied heights caused the tiles to catch light and prompt tactile engagement in unique ways. As I anticipate their use for MHNBC, the tiles reflectivity joins with the reflectivity of the water in the distance as a means to mediate interior and exterior. The details of material surface connect with the broad planes of the shell banks and the infinite light of the sky through which the godwits pass. (Figures 77, 78)

My design approach for the MHNBC brings together a concern for the spatial environment and material details. My methods allow an interplay between these two registers, opening a dialogue resolved through iterative making.



Figure 74. Exhibition setup of material with stool and mainframe staging three dimensions of material exploration: raw, experimental, and tiles.



Figure 75. The experimental layer holds a range of material tests: adobe bricks, leftover clay, and marbling red and white clay.



Figure 76. Using the exhibition to test tile tessellation and potential methods in using the raw edge left for each tile.



Figure 77. The lightness of glass-reinforced concrete slabs are exaggerated by the lightness of welded frame.

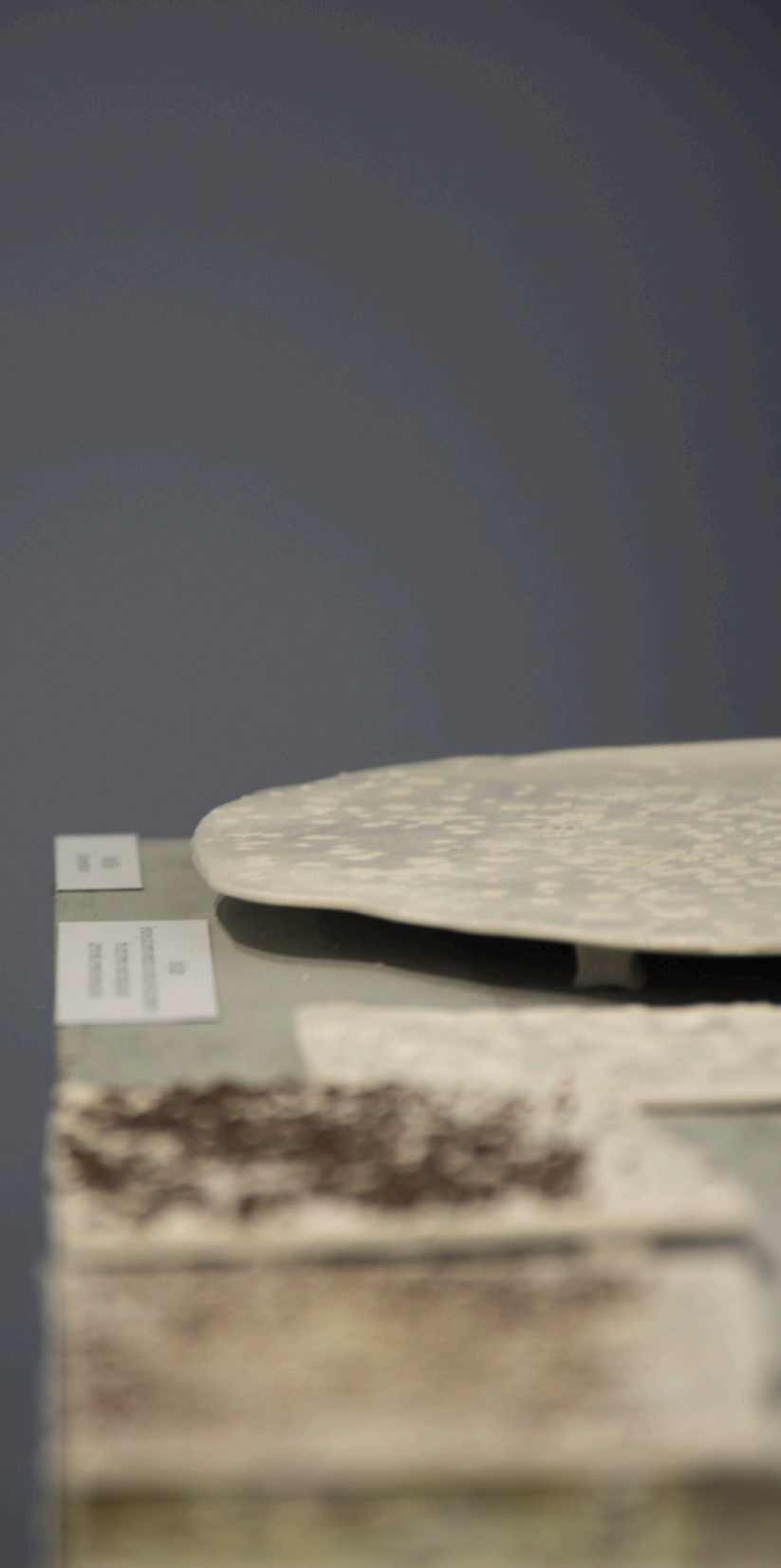

Figure 78. Negative detail under tiles investigates strategies for exhibition material for the conceptual proposal.

Findings

My concept proposal for a new MHNBC will be exhibited in the first week of November 2017. The MHNBC performs more than a platform for viewing bird rather stages conditions to diffuse the perception of a boundary between human – nature – other organism, encouraging an ecology of we. The proposal will consist of maps, a drawing set, perspectival renders, models, and material samples focusing on narrating the experiential encounters throughout the proposal.

This practice-led research asks how *peripheral experiences* can become an agency for the *inter-personal*? In particular, how might *light*, *movement*, and *textural surfaces* be crucial in producing an 'ecology of we'?

I seek to explore our peripheral experiences with the world and critique our tendency to disengage with our surroundings. The existence of our being is built from the unconscious, shared peripheral experiences rather than a subjective encounter. *Light*, *movement*, and *textural surfaces* as atmospheric conditions open up peripheral engagement through Gernot Böhme and Peter Zumthor's theories of atmosphere as externalised forces. Atmosphere establishes grounds for the *inter-subjective* encounter where an *ecology of we* emerge.

My core practice focuses on experiential engagement as methods to understand atmospheric spatial arrangements. While my methods seem to lack any direct inter-personal dialogue between people, which my research hinges on – forces within the project suggests the *inter-personal* occurred internally. Moments within: site walks considered views of my parents, *Microcosm* invited public viewing of my work, *material narratives* collaborated and conversated with Harriet (AUT Wetlab technician) were all significant inter-personal encounters. Inter-personal in this project does not limit to the viewing of another's engagement rather, as the designer, I also embodied the *inter-personal* moments that I seek to design.

This exegesis (along with my practice work) has advanced a dialogue of peripheral engagement as an agency for *inter-subjective* experience. What is the agency of *peripheral experience*? How can it act on us? This project attempts to demonstrate how *peripheral experience* can construct an atmosphere that is more than personal, creating *empathy* with others – human and nonhuman.

Exhibition: Manukau Harbour Native Bird Centre

Firstly, addressing examination was taken one month after the exegesis submission when the final architectural scheme was at the final stages of design and visualisation. This chapter documents exhibition/examination setup and a discussion of how earlier experiments working between installation and ceramic practices influenced spatial configuration.

The research brief works in conjunction with MHRS and their aspiration for the proposal of a native bird centre along the foreshore of Manukau Harbour. MHRS are currently in the stages of gathering resources and in discussion with Auckland Council and the local iwi: Ngāti Te Ata, Ngāti Tamaoho, and Te Ākitai Waiohua. (Kōkiri, 2005)

However, the research project detaches from this timeline and proceeds to conceptualise a draft scheme for MHRS that can be considered for future development. My earlier decision to advance the project allows the project to set a different pace for a live project and continue a more experimental making. In hindsight, the inclusion of MHRS would have offered more opportunity for inter-personal exchanges and broadening parties involved that could have further sophisticated the final architectural scheme.

Exhibition/examination setup

Drawing on earlier installation practices, the format of the presentation was considered a more participatory reading of the project final scheme. The exhibition/examination setup was strategised into two sides: Microcosm and MHNBC. By withdrawing from a conventional pin-up of work on a flat surface, the work hovers in the room as clusters of objects, inviting movement around the work. Consequently, this amplifies the effectiveness of the draped prints and models (Figure 79). The A-frame suspension system is the property of AUT fabricated by Meredith Hayward.

Microcosm exhibits four enlarged curated photographs, 1380 x 500 mm, marking four crucial moments of the installation experiments. These moments consist of camber moments, vertical periphery, draping paper edge conditions, and reflective surfaces (Figure 80). These four selected photographs become precedent to the interior lighting, reflective material qualities and edge conditions between spaces.

Along the opposite side displays five panels, 1380 x 800 mm, of the architectural scheme: site investigation, floor plans, arrival, ramp feature, and exhibition interior (Figure 81). Accompanying the prints are the tiles from particulate surfaces and a 1:100 scale CNC-laser cut model. (Figure 82, 83, 84)

Architectural scheme

MHNBC immerses occupants to their peripheral experiences through atmospheric gestures of light, movement, and textural surfaces producing an 'ecology of we'. The precedential atmospheric gestures draw from earlier experiments, working between the embodied and representation.

Firstly, the formality of the scheme is developed through modes of Modelling and Drawing that roughly plans the allocation of programmes. (Figure 85, 86, 87) Light exploration in Microcosm informs the forms of the sawtooth structure. The lightness of this roof construction allows the breath and flow between interior and exterior while exaggerating the sense of horizontal and vertical periphery (Figure 88). Utilising the sawtooth structure as a strategy for a repetition of light channels mimics my experiences in Walking and Flying under overgrown foliage. This is revised with tile-clad ceiling from Particulate Surfaces, utilising the reflective quality and varying textures to dampen and soften the northbound sunlight. By offsetting

the tiles to a 10-degree angle, this produces shadows under each row of tiles rippling throughout the interior ceiling (Figure 89) – a similar effect to the organic edges from the overarching foliage.

These slight adjustments to light conditions follows Pallasmaa's "[p]eripheral unfocused vision" (Pallasmaa, 2012, p. 10), so the subtle spectrum of light envelopes our periphery tuning one to the atmosphere. The success works between representation and embodied methodologies drawing on Modelling and Drawing architectural formality to the sensory experiences of Microcosm. It is crucial to work between scales; the embodied and architectural forms are intertwined. Whether the occupants view the external form, our sensory experiences already engages with the interior light and embodies the spectrum of effects. Though the sawtooth roof considered seasonal changes, the design was lacking in further addressing the potential heat and ventilation aspect of this exposed roof system. However, this was viewed as a minor issue during the development and did not detract from the primary study of light.

Secondly, movement through the architectural scheme adopts a motif of edge conditions discovered in Particulate Surfaces ceramic studies (Figure 90). I derived lines from the edges of my ceramic tiles suggesting ground fractures on topography introducing varying level changes. Wasit Natural Reserve Visitor Centre utilises these topological shifts into the landscape to hide and mask into the natural landscape. The use of these topological shifts mimic a bird's mobile perspective, inciting an empathic process to consider other organisms. Further, I implemented large glossy ceramic tiles scattered throughout the concrete manmade topography as a strategy to project and multiply subtle movements – movement, considered an atmosphere condition, thusly tunes occupants to engage with their peripheral surroundings, alluding to an inter-subjective space. A shared space between subjects

is connected by this engagement, and an acknowledgement of others further alludes to building an 'ecology of we'.

Lastly, the implementation of textual surfaces occurs on the laser etched tiles in the exhibition area as a strategy to offer a haptic experience, tying in to the education tile making programme (Figures 91, 92). The implementation of a tile making programme was intended to educate people to the locally source materials used in the scheme. The kits are designed as a pair activity with the effort of two to imprint patterns from the exhibition plaques and around the site (Figure 93). This encourages movement through and around the architecture; considering the sensory experience of seeing movement, running, or shouting of children livens the centre as an approach to an 'ecology of we'.



Figure 79. Examination/exhibition formatted as a cluster of objects separated into Microcosm and MHNBC.



Figure 80. Microcosm, 4 curated photographs printed on 1300 x 500 mm canvas marking 4 key moments of camber, vertical periphery, edge condition, and the micro.



Figure 81. Manukau Harbour Native Bird Centre proposal, 5 panel reading left to right; site analysis, plans, arrival, ramp (edge condition), and interior of exhibition. The proposal is read between the models

and material palette framed on steel welded frames.



Figure 82. MHNBC, perspective of exhibition layout centred around the model.



Figure 83. CNC contour model with laser cut of main structural form at 1:100 scale.



Figure 84. 1:100 scale model, looking back onto the east façade of exhibition pavilion drawing the edge condition and shift of topography from the artificial terrain.

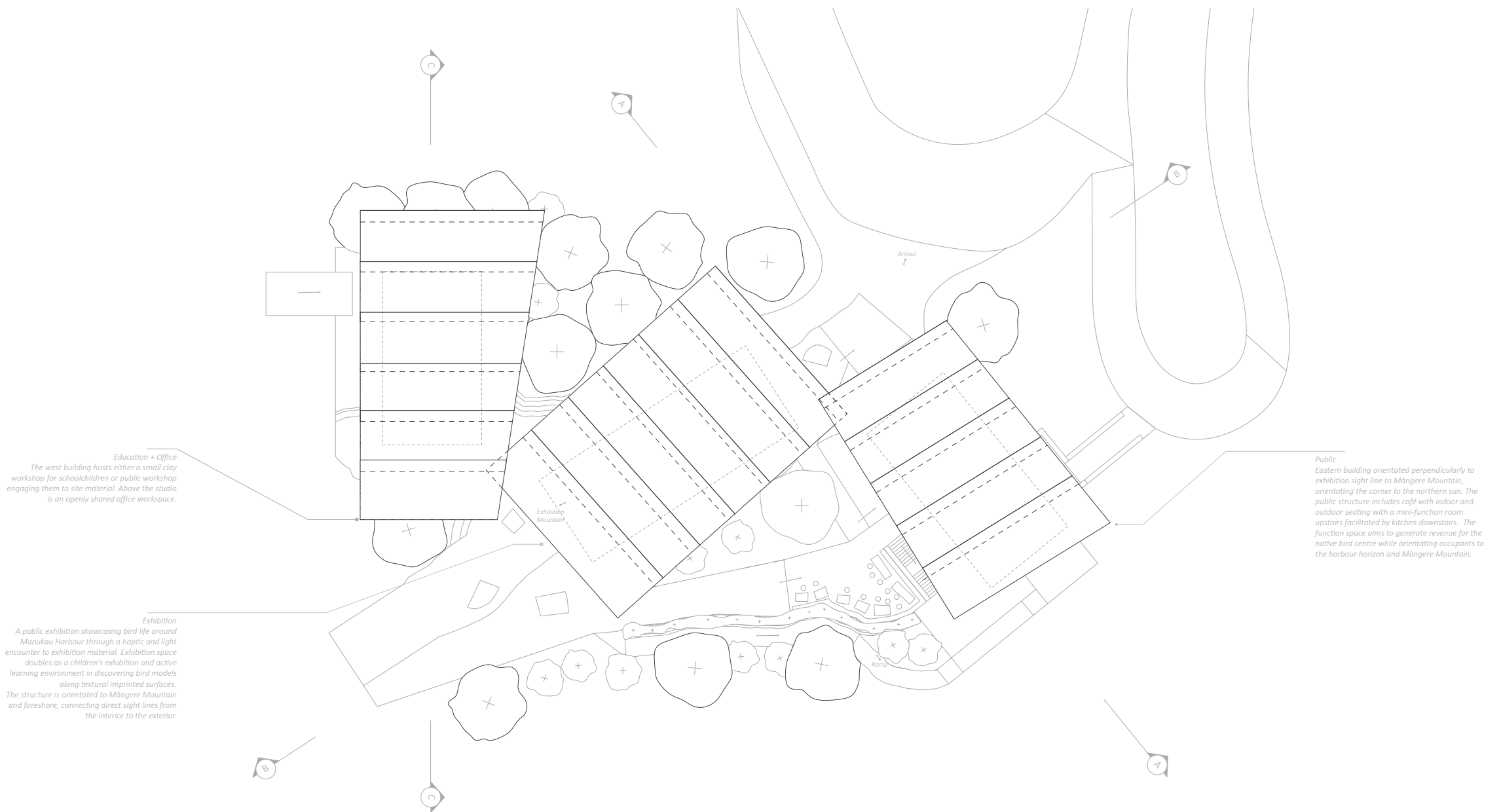
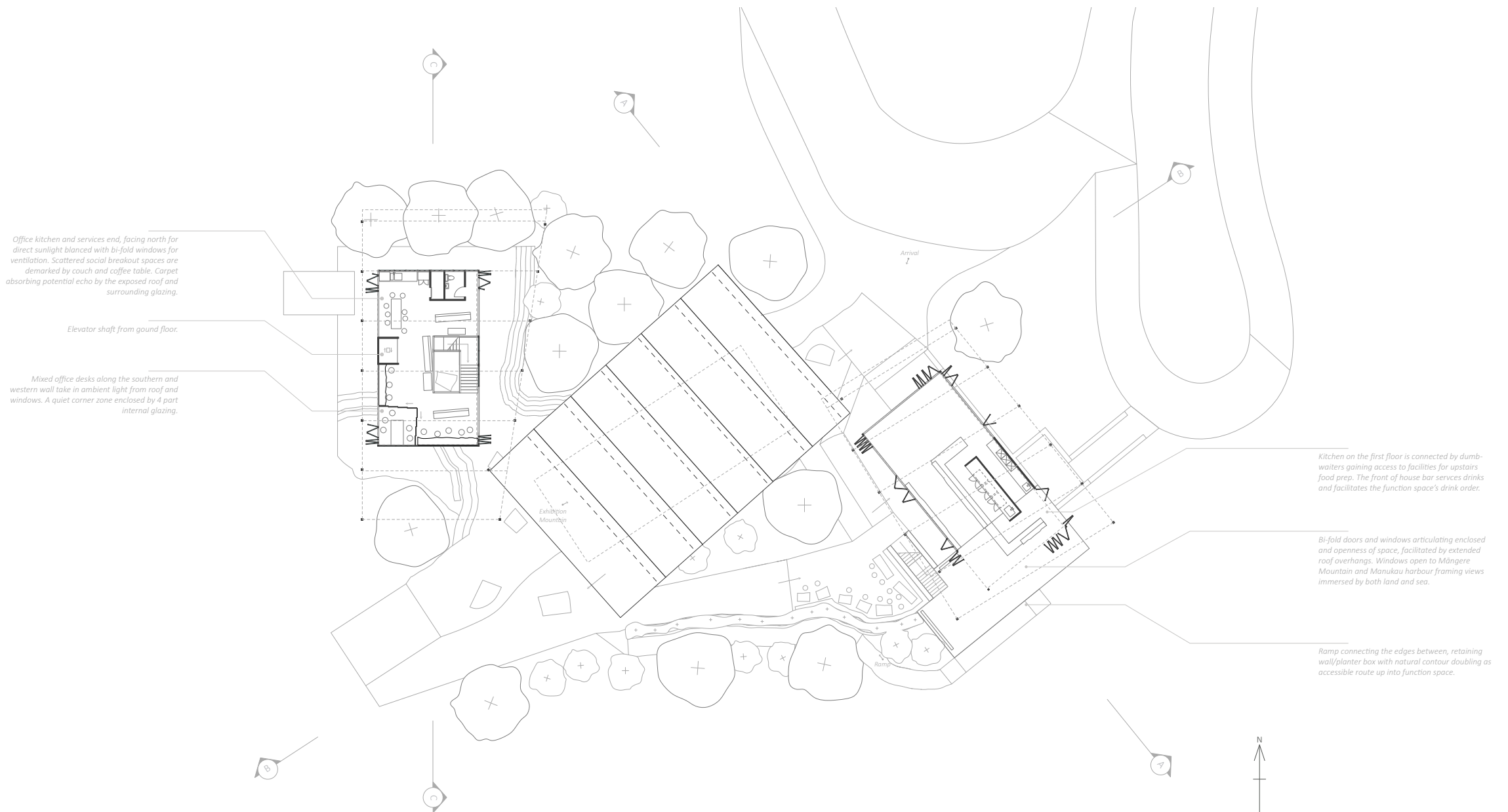

Figure 85. Roof plan, form and extension of eaves.



First floor plan

Figure 86. First floor plan, function room and offices.

A range of proposed trees consisting of tawa as a potential self-regenerative species, pohutukawa, totara and rimu.

Garage and storage for site surveying tools.

Mini-amphitheater workshop area with seats set into the ground, bringing occupants down to the ground line. This draws their horizon lower, so they react to subtle movement projected from reflective tiles scattered throughout the ground. It's covered by extended double height overhangs, creating a buffer zone with an overgrown tawa tree filtering external elements. The interior is controlled by bi-fold doors, enclosing and exposing to the elements.

Exhibition line traces the edge of rolled out clay to create varying movements of expansion and contraction of the edge. Interior steps with laser-etched tiles containing shore bird facts arrayed along the organic line.

Scattered tiles creating reflected lightwells into dark interiors and mirroring movement into the periphery around the centre. White Clay + Shell glazing (crazing effect leaving chips of shells giving texture and grip to ground surface) + Imprinting shell pressed texture per tile + Cracked (to fire in smaller pieces) and joined by slaked lime

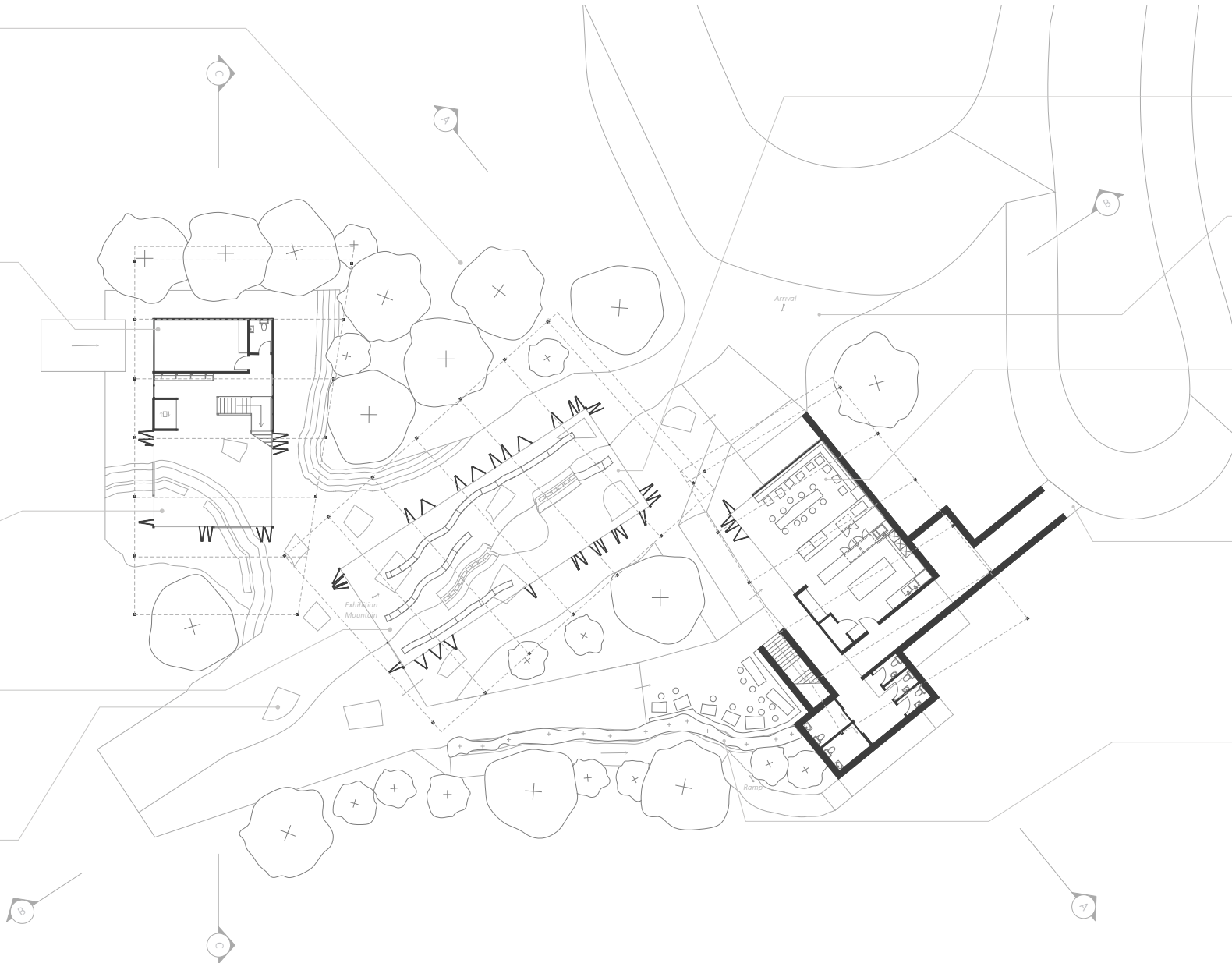

Reception/information desk set into the edge of exhibition step; the form of the desk continues and joins the lines. A central contour piece orientates viewers towards significant land features.

Arrival drop-off zone passes through bus-turns and services entrance. Ground – white concrete composition with more lime and shell aggregate exposed by grinding top layer with a matte circular grind finish.

Corner bench seats set into the ground with ambient light flooding through window glazing, brushing through trees and greenery whilst illuminating the central shadow of the café table.

Services entrance for café and function space.

The planter box overgrows, covering lime wall with chiselled texture supported by steel frames, lifting plants from the wall. The box consists of shrubs of pohutukawa, harakeke flax or needlegrass.

Ground floor plan

Figure 87. Ground floor plan, concrete topography, café, exhibition, and education space.

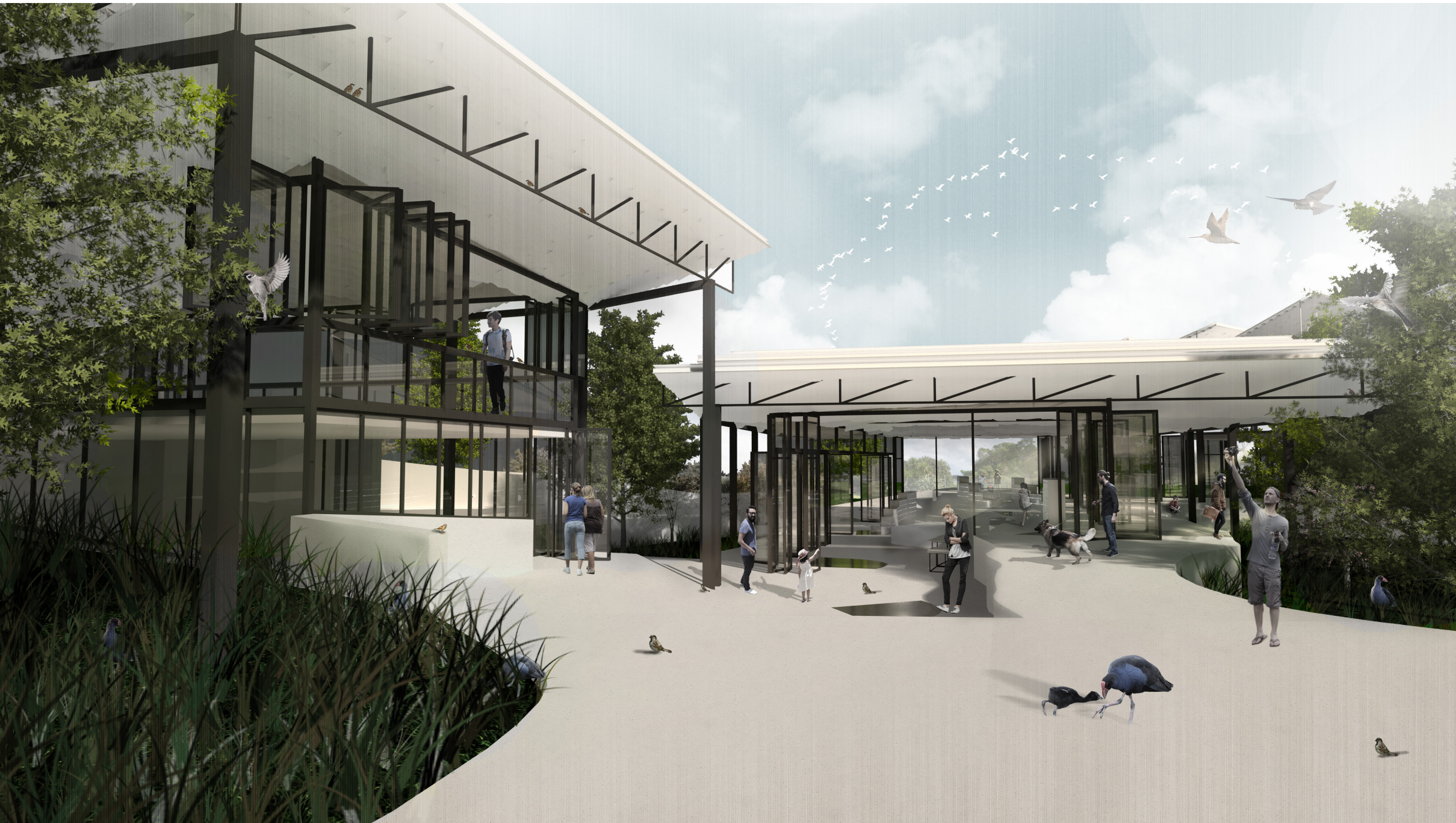
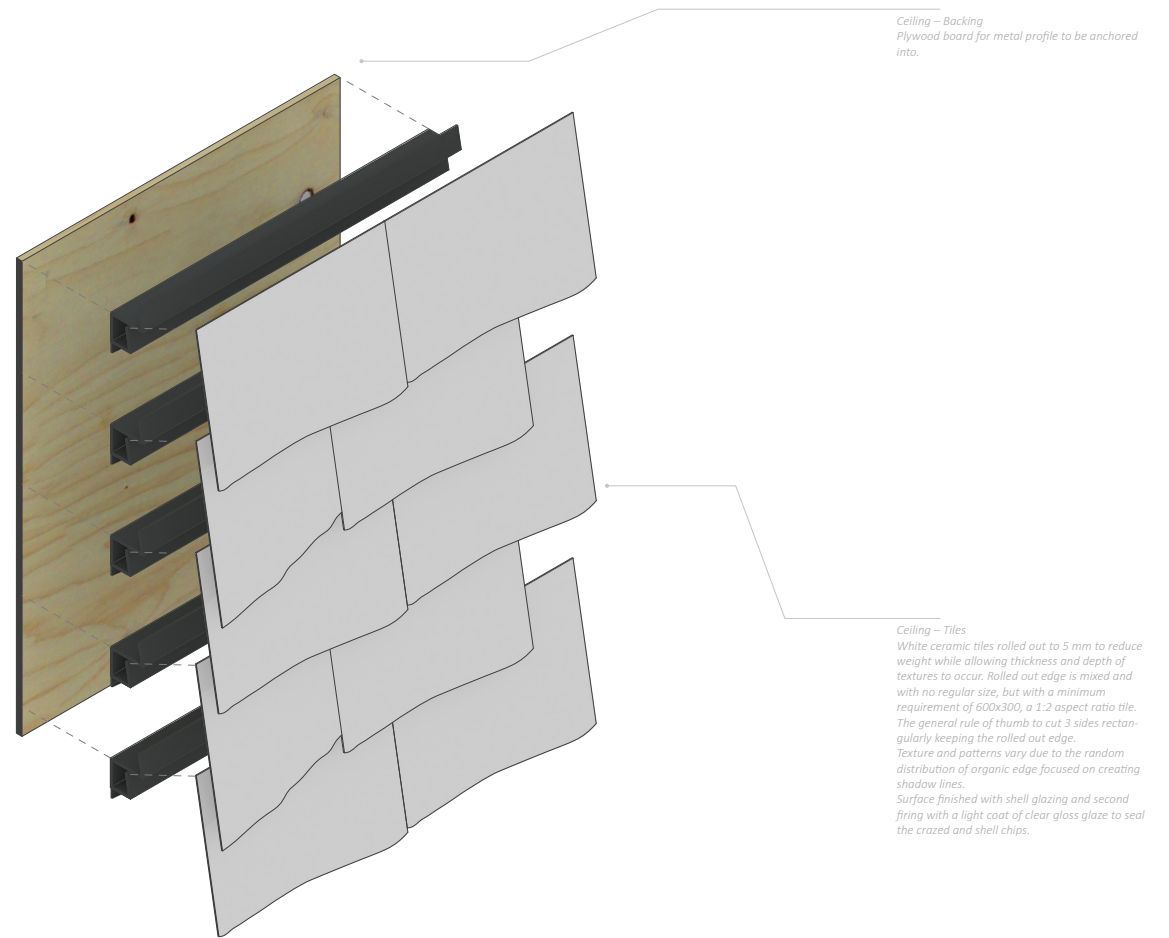

Figure 88. Arrival – entering from bus turn or vehicle drop-off zone looking through the exhibition pavilion framing the Manukau Harbour foreshore.

Ceiling – Metal profile
3mm Aluminium sheets bent to shape with a bottom flange welded for extra surface anchor points.

Ceiling – Tiles
White ceramic tiles screwed onto the lower half of the metal profile elevated by the next metal beam, retaining a consistent 10 degrees with 190mm centres.
The slight elevation creates shadow lines mimicking the organic, rolled out edge of the tile. A repeated element like tides of waves with different density and variation by the varying pitches of roofs.

Ceiling



Ceiling

Figure 89. Roof tile detail, exploded axonometric detailing the tectonics and materiality of the ceiling.

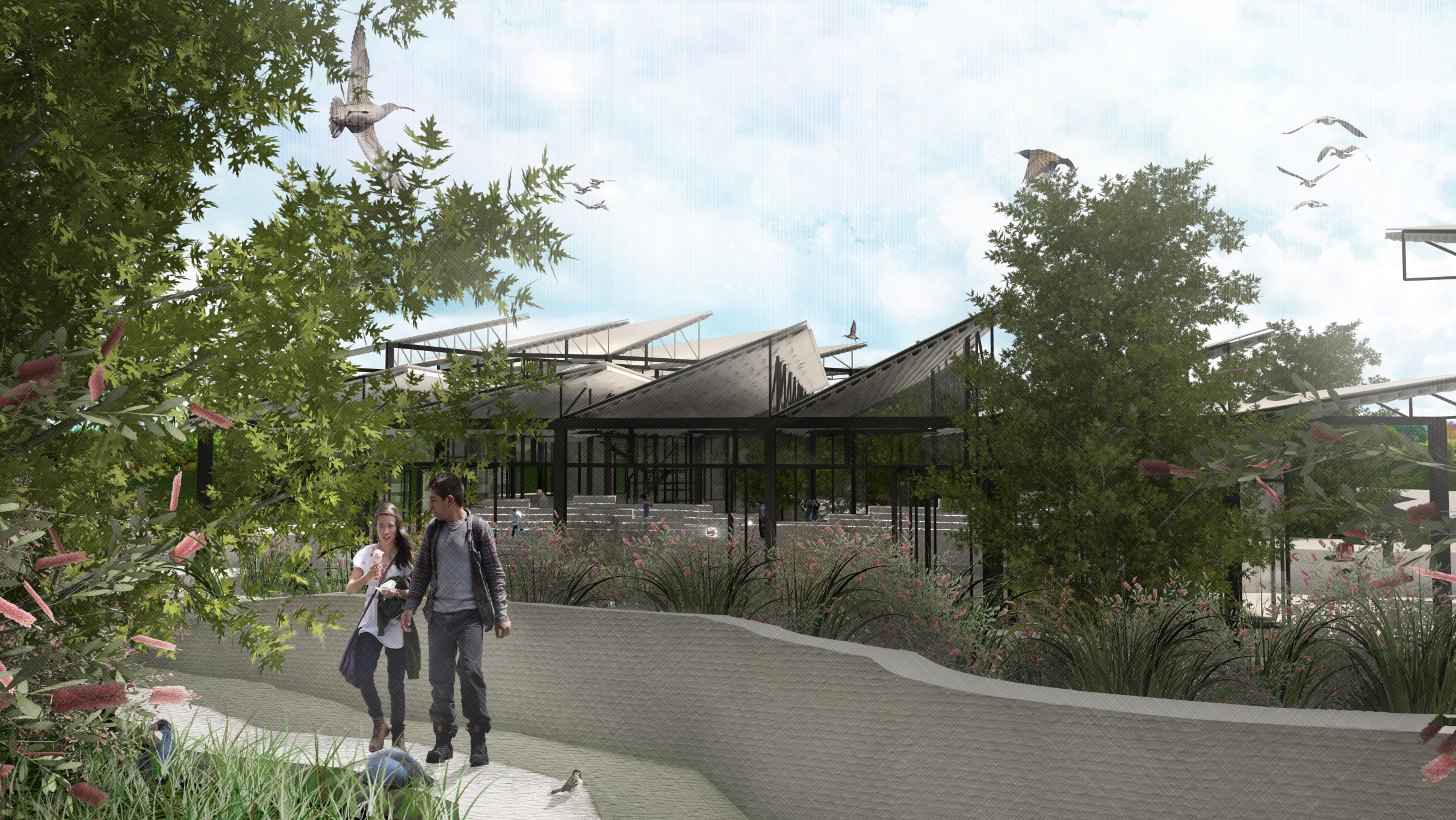

Figure 90. Ramp – standing by the perimeter of the artificial topography looking through layers of foliage facing the East elevation of exhibition pavilion.

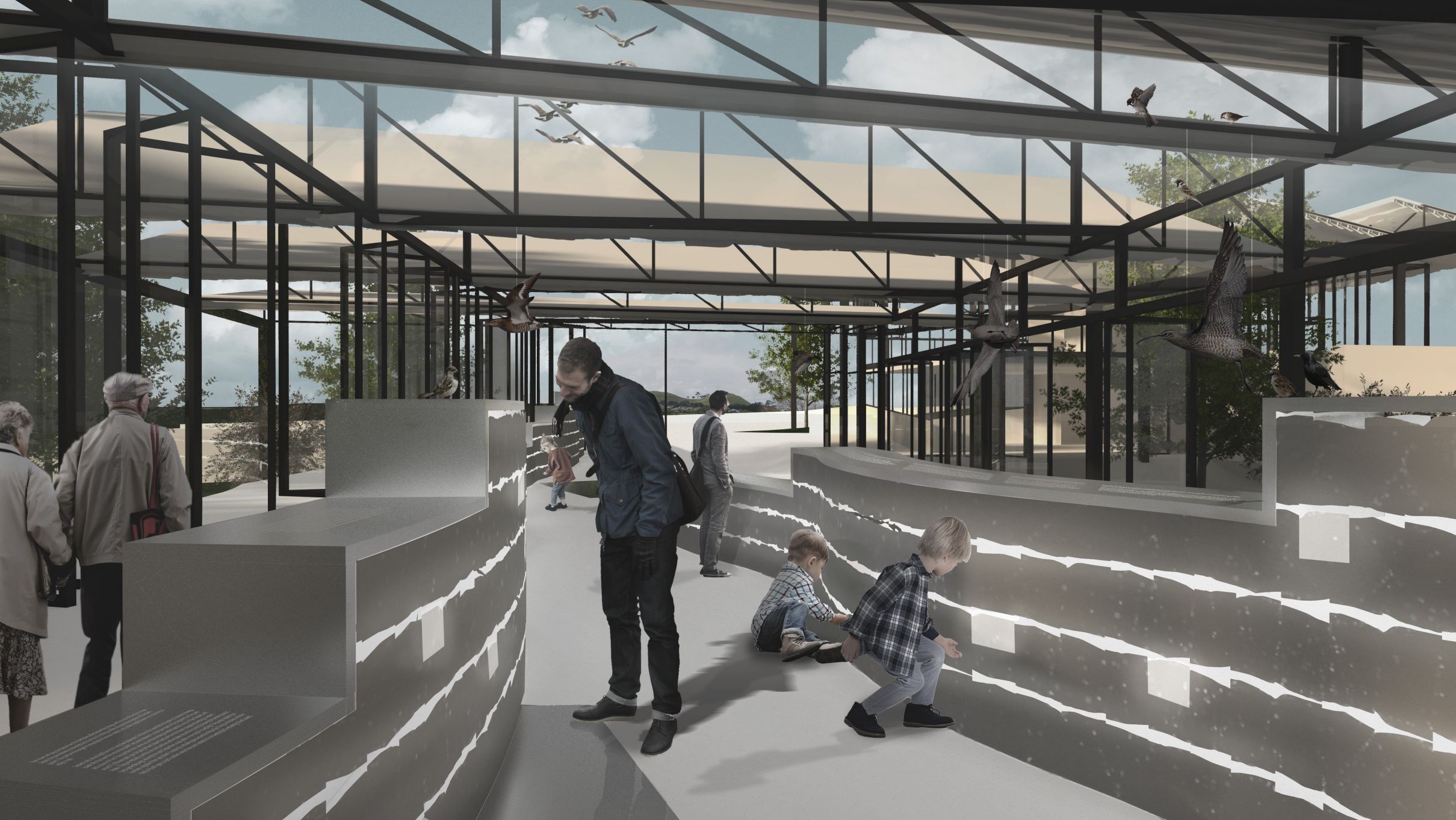
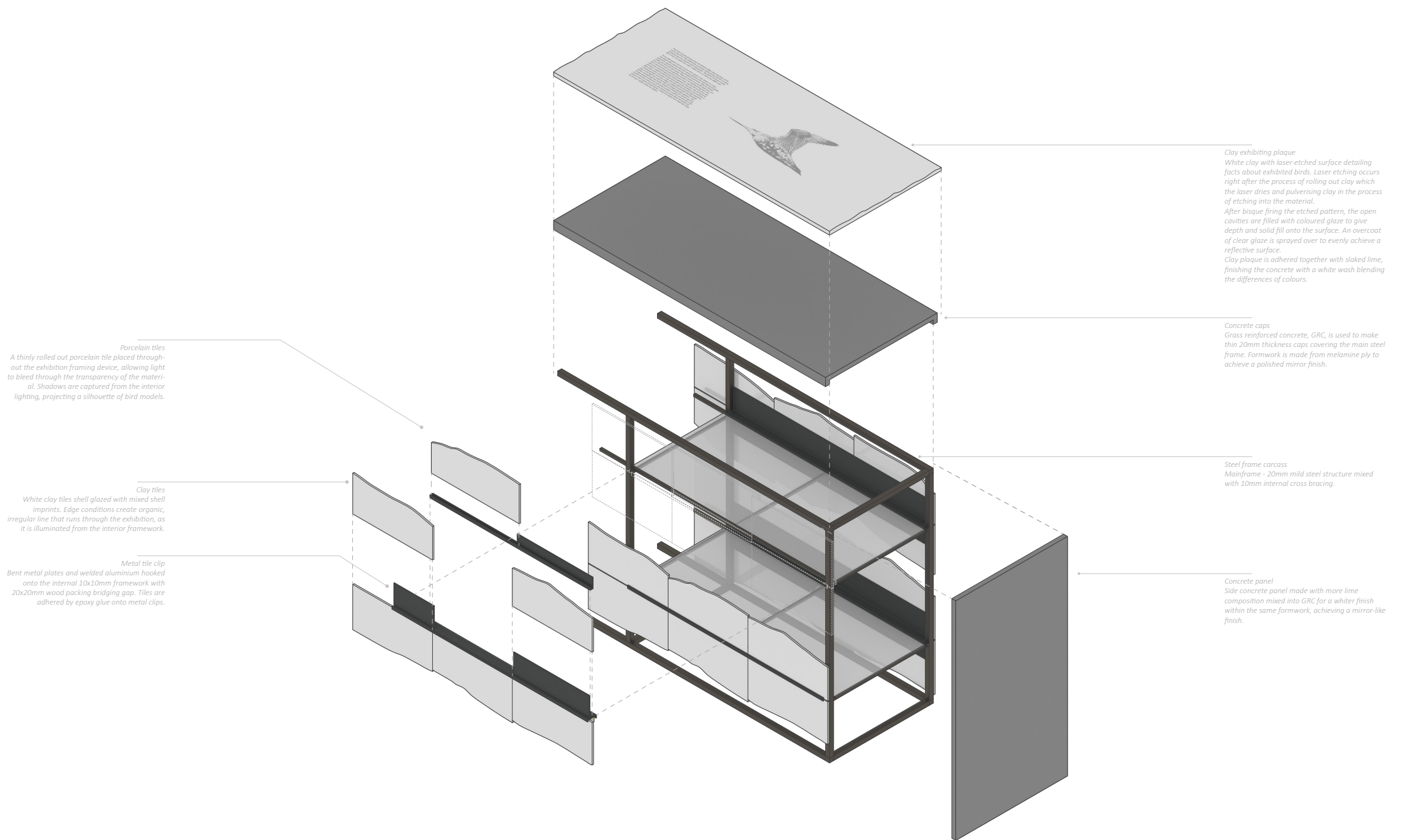
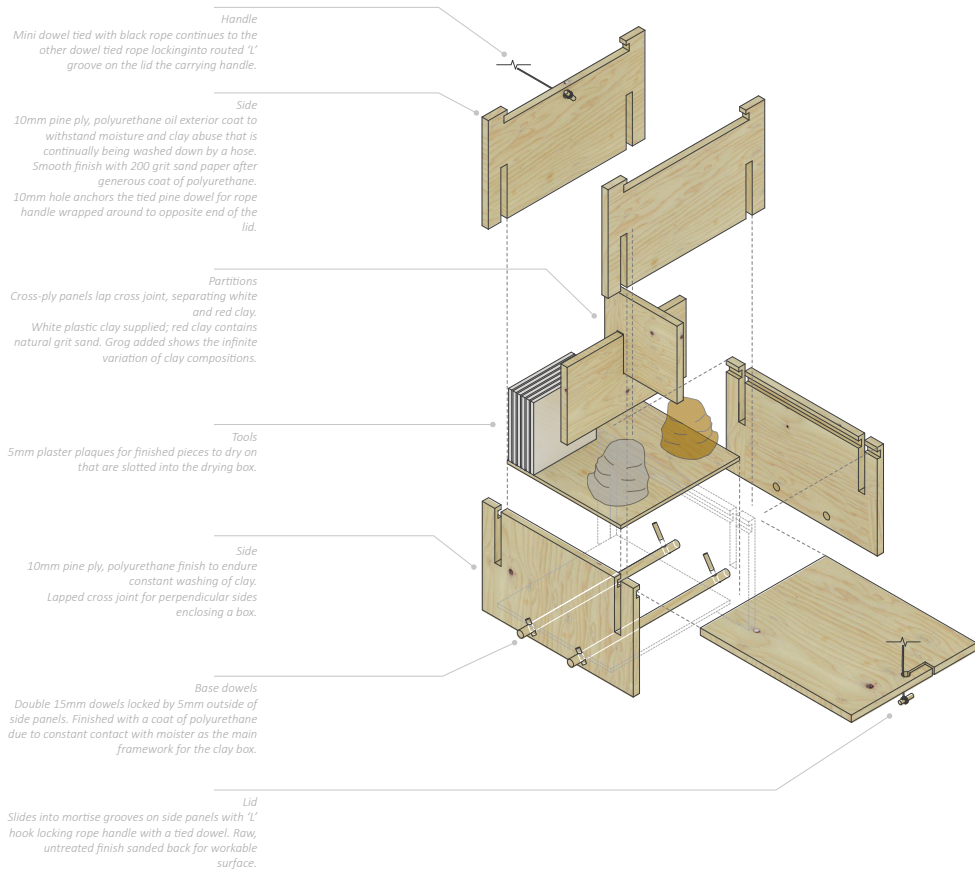

Figure 91. Exhibition – looking back towards Māngere Mountain framed by the steel structure housing exhibition cabinets with laser etched plaques transparent ceramic tiles.



Framing light box

Figure 92. Exhibition cabinets, exploded axonometric detailing tectonic, materiality, and kinetic element of porcelain tile.



Clay kit - Clay box

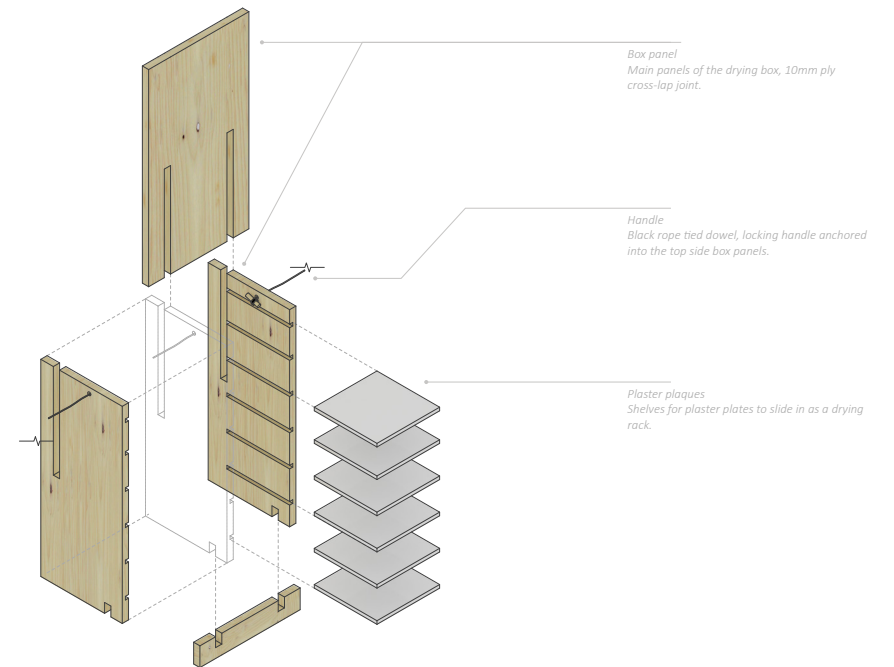

Clay kit - Drying box

Figure 93. Clay kit, axonometric detailing of clay kits for children to take imprints of laser etched tiles containing patterns of birds being exhibited.

Appendices

Appendix A. Concept brief provided by MHNBC working group

MANUKAU HARBOUR NATURE CENTRE

1

CONCEPT PAPER OUTLINE

Draft April 10, 2016

This lays out potential activities and facilities for discussion. It is intended these concepts will be refined through engagement with interested groups and feasibility analysis. Not all activities or facilities may be pursued while new ones may be identified through the input and analysis phases. Complementarity with cultural and recreation nodes around the foreshore and broad community support for the centre are desired.

Vision: to develop a nature centre that showcases the birds and the natural history of the Manukau Harbour, that is imbedded in the harbour community and is a renowned international research and education resource. It encourages people to support appropriate protection and management of the harbour for the birds and other natural features.

Target audiences:

- Primarily Auckland residents
- Local community
- Schools
- Tertiary and scientific institutions for teaching and research
- Natural history special interest groups
- Also local tourists and from overseas

Activities:

Education

- Displays
- Guided walks
- Self-guided walks (pamphlets, signage and/or phone apps)
- Lectures, talks and events
- Teach part of the school science curriculum

Monitoring and Research

- Support interest groups
- Tertiary and scientific institutions
- Citizen science projects
- Individual projects on topics of interest
- Watercare Centre of Excellence

Generate revenue

- Shop
- Café

DRAFT APRIL 2017

1

MANUKAU HARBOUR NATURE CENTRE

2

- Accommodation
- Space rental and events

Facilities:

- Visitor centre to meet and greet with displays, support facilities
- Shop
- Classrooms, lecture /presentation facility, meeting room
- Café plus kitchen/tea room for volunteers, researchers, staff
- Research facilities and equipment including office, lab space and gear storage
- Laundry facilities, gear and personal
- Accommodation
- Handicapped access
- Information nodes at key sites
- Multitmodal and handicapped- accessible trails connecting to foreshore, maunga, local communities, and regional trail network
- Utilities (power, water etc) and telecommunications, sufficient to support research
- Parking and turning for vehicles and buses

Initial staff:

- Manager/coordinator
- Specialist educator for schools and public

Location:

Preferably Ambury Regional Park, Watercare foreshore, Gun Club at Otutata Stonefields

- Easy access to bird watching vantage points, features of interest
- Close to Auckland with good access for community - public transport and regional trail network connections, handicapped accessible
- Close to airport
- Complementary to other regional nodes on foreshore
- Boat access to harbour for research?
- Easy, low cost access to trunk utilities; low land acquisition costs

Initial work program:

- Prepare concept
- Refine concept with input from community and iwi, business, local bodies and local interest groups and develop support
- Stage the project into manageable and sequential steps
- Seek funding to get started.
- Work through the planning stages.

DRAFT APRIL 2017

2

Initial potential funders:

- Auckland Council, Local Boards
- Foundation North
- Logan Campbell Trust?
- Tindall foundation
- Local gaming trusts?
- Watercare?
- Donated services

Initial potential partners:

- Local interest groups eg shell club, Botanical Society etc
- Local community groups
- Local and national government – Auckland Council, Watercare, DOC
- Iwi
- Local and national research institutions eg Auckland Museum, AU, AUT, NIWA
- Local businesses eg Airport, Villa Maria, Waste Management/Living Earth, fishing companies

Potential benefits:

- Making it easy for Aucklanders and other visitors to learn about the birds and develop a passion for their care and protection.
- Community awareness of the harbour, pride and increased awareness of its values.
- Economic benefit to the local community
- A community centre for community activities and events
- Accessible green space
- Tourism centre for a world class birding site.
- Top quality education and research centre for local schools, tertiary and scientific institutions
- Directly and indirectly generate knowledge that allows better management of the harbour for birds and other natural values.
- Generate support for appropriate care of the harbour

Lead Organization:

- A working group comprised of representatives of MHRS, BirdsNZ, local community, iwi, Auckland Council, Watercare, and special interest groups







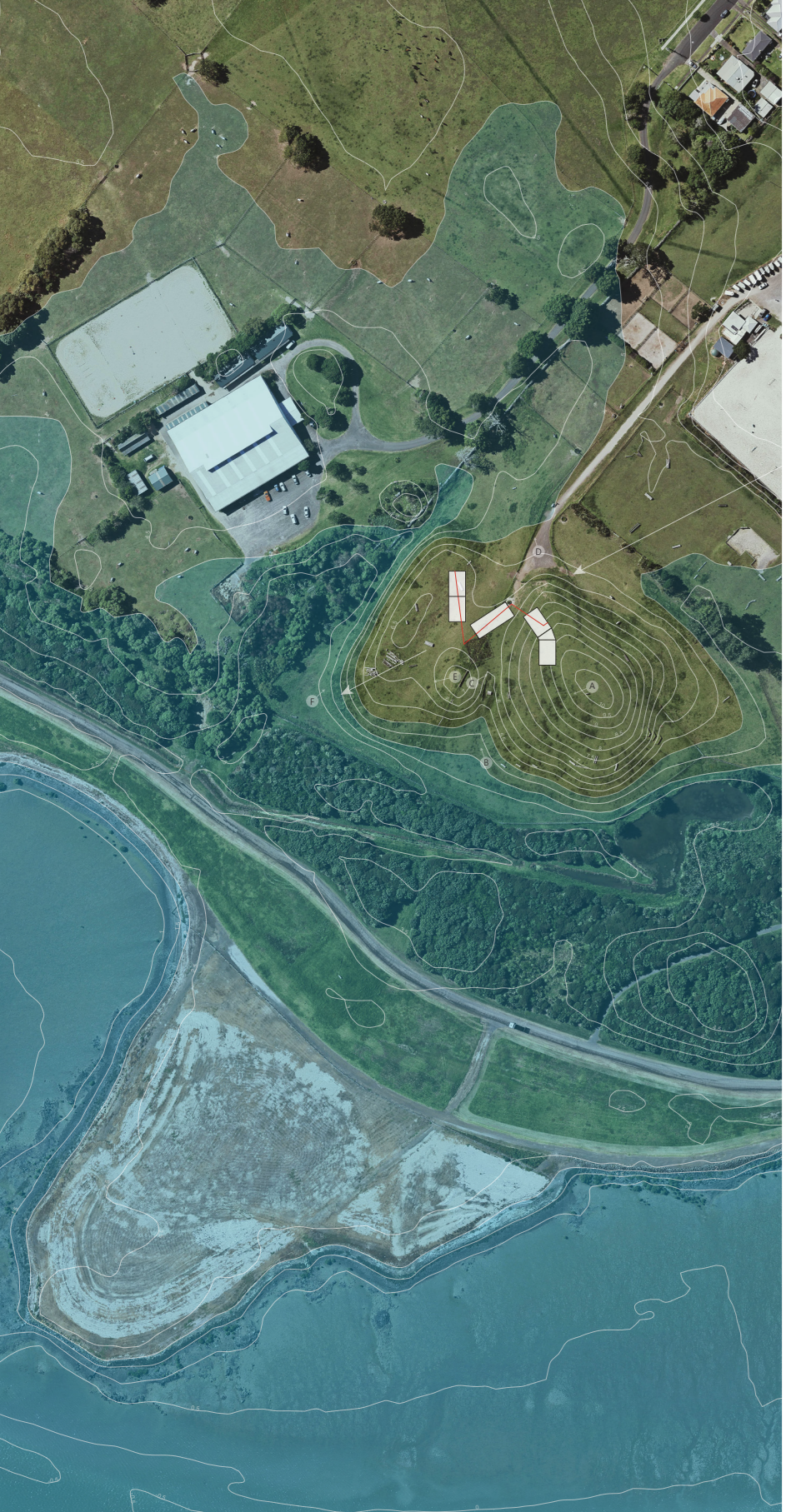

Hill Top - Muddy, sinking, gusty winds. Puketutu Island sitting on the horizon line peering through foliage along the foreshore.



Between Hills - Unexpectedly quiet, closed off, where is Mangere Mountain? Standing beside the foreshore fence line dense still foliage.



Right Side Fence - A little lift on contour but foreshore is still covered by the tree line. Proposal demolishes fences for easier transition between sides.

N

C

S



Cross Road - Gravel road, patchy water. Three way intersection proposed vehicle traffic with bus turn.

S

D

N



References

Baek, J. (2015). The ecology of 'we' and ambient warmth: Richard Neutra's ecological architecture. *ARQ: Architectural Research Quarterly*, 19(4), 349-359. doi:10.1017/S135913551600004X

Baek, J. (2016). *Architecture as the ethics of climate*: Abingdon, Oxon ; New York : Routledge, 2016.

(2014, 2014). The Flight of the Godwit - Science Express [Retrieved from http://channel.tepapa.govt.nz/audio/the-flight-of-the-godwit/?utm_source=feedburner&utm_medium=feed&utm_TePapaScienceExpress+%28Te+Papa+Science+Express%29&utm_content=FeedBurner

Böhme, G. (2014). *The theory of atmospheres and its applications* (translated by A.-Chr. Engels-Schwarzpaul). *Interstices: Journal of Architecture and Related Arts*.

Fernandez-Juricic, E. (2010). Bird vision explained. Retrieved from <http://estebanfj.bio.purdue.edu/birdvision/visualfields.html>

Formafantasma. (2012). *Craftica*. Retrieved from <http://www.formafantasma.com/craftica>

Formafantasma. (2014). *De Natura Fossilium*. Retrieved from <http://www.formafantasma.com/de-natura-fossilium>

Ha, T.-H. (2015). *WE HUMANS*. Inside the world's best kindergarten Retrieved from <http://ideas.ted.com/inside-the-worlds-best-kindergarten/>

Hitzel, E. (2015). *Effects of peripheral vision on eye movements : a virtual reality study on gaze allocation in naturalistic tasks*: Wiesbaden : Springer, 2015.

Hobson, B. (2013). Eindhoven design studio Formafantasma is "experimenting with lava". Retrieved from <https://www.dezeen.com/2013/11/29/movie-formafantasma-unusual-materials-fish-skin-cow-bladders-animal-blood-lava/>

Kōkiri, T. P. (2005). *Te Kāhui Māngai* Retrieved from <http://www.tkm.govt.nz/>

Lowe, A. (2016). *Host of Shadows: Slowness, wabi-sabi, and the tea ceremony*. (Bachelor in Art & Design, Honours, Spatial Design Disseration), Auckland University of Technology.

O'Rourke, K. (2013). *Walking and mapping : artists as cartographers*: Cambridge, Massachusetts : The MIT Press, [2013].

Pallasmaa, J. (2012). *The eyes of the skin: architecture and the senses*: John Wiley & Sons.

Tezuka, T. (2014). The best kindergarten you've ever seen. Retrieved from https://www.ted.com/talks/takaharu_tezuka_the_best_kindergarten_you_ve_ever_seen#t-575344

Wasit Natural Reserve Visitor Centre / X Architects (22 Mar 2016). Retrieved from <http://www.archdaily.com/784055/wasit-natural-reserve-visitor-centre-x-architects>

Woodley, K. (2013, 2017). *Bar-tailed godwit*.

Zumthor, P. (2006). *Atmospheres: Architectural Environments-Surroundings Objects*. Germany: Birkhäuser.

Zumthor, P. (2016). Allmannajuvet Zinc Mine Museum. Retrieved from http://www.archdaily.com/796345/allmannajuvet-zinc-mine-museum-peter-zumthor?ad_medium=widget&ad_name=navigation-next

