

Assessing Microclimate and Outdoor Thermal Comfort in the Urban Environment: A Case Study of Auckland, New Zealand

A thesis submitted to Auckland University of Technology in fulfilment of the requirements for the degree of

Doctor of Philosophy (PhD)

May 2024

School of Future Environments

Auckland University of Technology

By

Saghar Hashemi

Primary supervisor: Professor Amirhosein GhaffarianHoseini

Second supervisor: Professor Ali GhaffarianHoseini

Third supervisor: Associate Professor Nicola Naismith

Abstract

Urban microclimate and outdoor thermal comfort play a critical role in enhancing liveability, particularly in dense urban environments. The impacts of climate change, the urban heat island effect, and growing urban populations necessitate a deeper understanding of how urban design influences microclimates and thermal comfort. This research aims to investigate these dynamics at Auckland University of Technology (AUT), New Zealand, focusing on identifying thermal risk areas and proposing strategies to mitigate negative impacts through informed urban design.

The research addresses a significant gap in the literature on outdoor thermal comfort in temperate oceanic climates (Cfb), especially in the context of Auckland. Despite extensive studies in other climate zones, research on cities with similar climates remains underexplored. This thesis provides a comprehensive analysis, drawing on insights from New Zealand, and aims to contribute to the development of design guidelines to improve thermal comfort in urban settings.

A mixed-methods approach was employed, combining field measurements, site observations, and surveys, alongside computational fluid dynamics (CFD) simulations using Envi-met and ANSYS software. Field data were collected to assess meteorological conditions, while surveys captured pedestrian thermal perceptions. Simulations were used to model the microclimate and outdoor thermal comfort across various design scenarios.

The research follows six main phases: (1) assessing previous location selection criteria for analysing microclimate and outdoor thermal comfort, (2) reviewing existing studies on outdoor thermal comfort in Cfb cities, (3) analysing microclimatic research in New Zealand and Australia to identify gaps and provide recommendations, (4) identifying thermal risk areas at Auckland University of Technology (AUT) and proposing new design scenarios to reduce

thermal discomfort, (5) assessing pedestrian wind speed levels at AUT by defining a modified wind comfort criterion for Auckland, and (6) analysing the impacts of historical and predicted future climate data on the outdoor thermal comfort of Auckland.

The key findings reveal that high-density areas with limited greenery exhibit elevated thermal discomfort, particularly during summer. Replacing concrete walls with green walls and planting trees significantly reduces thermal discomfort. Wind analysis demonstrates that street orientation, especially those angled at 45 and 90 degrees to prevailing winds, exacerbates wind discomfort, whereas parallel orientations reduce wind speed impact. Future climate scenarios predict an increase in outdoor thermal discomfort, with projected temperature rises of 5°C in summer and 4.5°C in winter by 2110 under RCP 8.5.

The research contributes original insights by proposing a modified wind comfort criterion for Auckland and demonstrating the critical role of greenery in mitigating thermal discomfort. It highlights the importance of street orientation and aspect ratios in wind-speed regulation. These findings offer valuable guidelines for urban designers, local authorities, and policymakers to enhance outdoor comfort in Auckland's urban environment, aligning future developments with climate-resilient strategies.

Content

Abstract.....	ii
Attestation of Authorship.....	xiv
Co-Authored works and Declaration of Collaboration.....	xv
Acknowledgements.....	xviii
Chapter 1 Introduction.....	1
1.1 Overview.....	1
1.2 Definition of urban microclimate and outdoor thermal conditions.....	1
1.3 The significance of microclimate and outdoor thermal studies.....	3
1.4 The definition of thermal risk areas.....	3
1.4.1 The layer of hazard (extreme thermal condition).....	4
1.4.2 The layer of exposure.....	4
1.4.3 The layer of vulnerability.....	4
1.5 Different approaches to investigating outdoor thermal conditions.....	4
1.5.1 Field measurements.....	5
1.5.2 Field surveys.....	5
1.5.3 Software simulations.....	5
1.5.4 Outdoor thermal indices.....	7
1.6 The parameters which influence outdoor thermal conditions.....	9
1.6.1 Geometry.....	9
1.6.2 Vegetation.....	10
1.6.3 Material.....	11
1.7 Rationale and Significance of the Study.....	12
1.7.1 Projections for future population growth in Auckland, New Zealand.....	12
1.7.2 Future climate change projections in Auckland, New Zealand.....	13
1.7.3 The number of studies that have been focused on "maritime climate" and "mild climate" are limited.....	15
1.7.4 A limited number of studies focus on outdoor thermal conditions in New Zealand, specifically in Auckland.....	15
1.7.5 Undeniable impact of outdoor thermal conditions on user's wellbeing, satisfaction, and quality of life.....	16
1.8 Research aim.....	17
1.8.1 Objective 1: location selection criteria and trends in previous microclimate and outdoor thermal comfort research.....	18

1.8.2 Objective 2: An assessment of existing microclimate and outdoor thermal comfort studies in temperate oceanic (Cfb) cities	18
1.8.3 Objective 3: Analysing previous microclimate and outdoor thermal comfort studies in Australia and New Zealand.....	19
1.8.4 Objective 4: Identify outdoor thermal risk areas.....	20
1.8.5 Objective 5: Analysing the impact of the most challenging climate factor, namely wind speed, on the pedestrian level of comfort	21
1.8.6 Objective 6: Analysing the impacts of historical and future climate change projections on the outdoor thermal comfort patterns of Auckland, New Zealand.....	22
1.9 Research contribution	23
1.10 Research method.....	24
1.10.1 Field surveys	24
1.10.2 Field observations	25
1.10.3 Field measurements.....	25
1.10.4 Software simulations.....	25
1.11 Location of research.....	27
1.12 Thesis organization	28
Chapter 2 Navigating the microclimates and outdoor thermal comfort studies: A comprehensive review of location selection criteria and trends	33
2.1 Prelude	33
2.2 Introduction.....	34
1. The impacts of morphology, vegetation, and building materials on microclimate	36
2. Thermal comfort and health risk evaluations.....	36
3. The productivity/competence of simulation tools in microclimatic studies and analysing outdoor thermal comfort	36
2.3 Method.....	37
2.4 Results.....	42
2.4.1 Neighbourhoods.....	42
2.4.2 Urban Street	48
2.4.3 University Campuses	53
2.4.4 Public Squares and Urban Parks	56
2.4.5 Public Courtyards.....	59
2.5 Discussion.....	62
2.6 Conclusions.....	65
Chapter 3 An assessment of existing microclimate and outdoor thermal comfort studies in temperate oceanic (Cfb) cities- A systematic review	69
3.1 Prelude	69
3.2 Introduction.....	69
3.3 Methodology	76
3.4 Critical analysis of microclimatic studies in Cfb cities.....	80

3.4.1 London	80
3.4.2 Melbourne	84
3.4.3 Other Cfb cities	88
3.5 Discussion	95
3.6 Conclusion	97
Chapter 4 A systematic review of microclimate and outdoor thermal comfort studies in Australia and New Zealand.....	100
4.1 Prelude	100
4.2 Introduction.....	100
4.3 Climate of Australia and New Zealand	102
4.3.1 Research significance.....	104
4.4 Methodology	107
4.5 Analysing existing papers in Australia and New Zealand.....	110
4.5.1 Melbourne	110
4.5.2 Sydney.....	115
4.5.3 Adelaide, Geelong and Darwin	118
4.5.4 Results of microclimatic and outdoor thermal comfort studies in Australia.....	122
4.5.5 New Zealand (Christchurch, Auckland, Wellington)	123
4.5.6 Results of microclimatic and outdoor thermal comfort studies in New Zealand.....	127
4.6 Discussion.....	128
4.7. Conclusion	130
Chapter 5 Summer Outdoor Thermal Risk Area Mapping on a University Campus in Auckland, New Zealand.....	132
5.1 Prelude	132
5.2 Introduction.....	132
5.3 Method	137
5.3.1 Research structure	137
5.3.2 Defining the layer of hazard (Phase 1a).....	138
5.3.3 Defining the layer of exposure (Phase 1b).....	141
5.3.4 Defining the layer of vulnerability (Phase 1c)	142
5.3.5 Future PET predictions for summer (Phase 2).....	143
5.3.6 Defining new scenarios (Phase 3).....	144
5.4 Results and Discussion	144
5.4.1 Preparing the layer of hazard (thermal stress).....	145
5.4.2 Preparing the layer of exposure (user intensity)	151
5.4.3 Preparing the layer of vulnerability.....	153
5.4.4 Identifying thermal risk areas	158
5.4.5 Investigating future PET for years 2050 and 2080 at outdoor thermal risk areas.....	159

5.4.6 Results of new scenarios for reducing PET (hazard layer) in outdoor thermal risk areas .	162
5.5 Discussions and limitations of the study	166
5.6 Conclusions.....	169
Chapter 6 Pedestrian-level wind speed analysis: A case study at Auckland University of Technology.....	171
6.1 Prelude	171
6.2 Introduction.....	171
6.3 Method.....	177
6.4 Evaluating public sensations of wind speed (Phase 1).....	178
6.5 Utilizing CFD to simulate wind speeds based on historical data (Phase 2).....	180
6.5.1 Agreement between Field Measurements with CFD Simulation Data	183
6.5.2 Results of wind speed analysis location 1.....	187
6.5.3 Results of wind speed analysis location 2.....	189
6.5.4 Results of wind speed analysis location 3.....	190
6.5.5 Results of wind speed analysis location 4.....	191
6.6 Defining mitigation scenarios in high-risk areas (Phase 3)	192
6.6.1 First Scenario: Increasing Aspect Ratio (add a new level).....	194
6.6.2 Second Scenario: Decreasing Aspect Ratio (remove an existing level).....	195
6.7 Discussion.....	195
6.8 Limitations of the study	197
6.9 Moving beyond local context.....	197
6.10 Conclusions.....	200
Chapter 7 The impacts of historical and future climate change projections on the outdoor thermal comfort patterns of Auckland, New Zealand.....	202
7.1 Prelude	202
7.2 Introduction.....	202
7.3 Method.....	206
7.4 Results.....	208
7.4.1 Validate the accuracy of Envi-met (Phase 1)	208
7.4.2 Analysing the average range of outdoor thermal comfort (Phase 2).....	213
7.4.3 Analysing the predicted future range of outdoor thermal comfort based on RCP 4.5 and RCP 8.5 (Phase 3).....	215
7.4.4 Results of new scenarios for mitigating outdoor thermal discomfort (Phase 4)	219
7.5 Limitations of the study and discussion.....	225
7.6 Conclusion	227
Chapter 8 Discussions, Conclusions and Recommendations	230
8.1 Overview.....	230
8.2 The Fulfilment of the Research Aim.....	230

8.2.1 Objective 1: location selection criteria and trends in previous microclimate and outdoor thermal comfort research	230
8.2.2 Objective 2: An assessment of existing microclimate and outdoor thermal comfort studies in temperate oceanic (Cfb) cities	232
8.2.3 Objective 3: Analysing previous microclimate and outdoor thermal comfort studies in Australia and New Zealand.....	233
8.2.4 Objective 4: Identify outdoor thermal risk areas.....	235
8.2.5 Objective 5: Analysing the impact of the most challenging climate factor, namely wind speed, on the pedestrian level of comfort	237
8.2.6 Objective 6: Analysing the impacts of historical and future climate change projections on the outdoor thermal comfort patterns of Auckland, New Zealand.....	239
8.3 Contribution and Significance of the Research.....	240
8.4 Research Limitations and Recommendations for Future Research	242
References.....	244
Appendices.....	303
Appendix A. Distribution of survey responses collected at both locations (n=347).....	303
Appendix B. A sample questionnaire.....	305
Appendix C. Relationship between Thermal sensation and responses to questions.....	305
Appendix D. Ethics approval and documents.....	309

List of Figures

Figure 1.1 Outdoor Thermal Comfort Parameters(Das et al., 2020).....	2
Figure 1.2 Differences and similarity between different software (Albdour & Baranyai 2019)	7
Figure 1.3 Previous number of studies that used different thermal indices (Lam et al., 2021)	8
Figure 1.4 Future climate prediction of Auckland (Davidson et al., 2020).....	14
Figure 1.5 Research framework	27
Figure 2.1 Paper Selection Criteria	39
Figure 2.2 The main locations studied by previous researchers, based on selected papers	40
Figure 2.3 Location selection criteria analysis - single neighborhoods	47
Figure 2.4 Location selection criteria analysis – multiple neighborhoods.....	48
Figure 2.5 Location selection criteria analysis - single urban streets	51
Figure 2.6 Location selection criteria analysis - multiple urban streets.....	53
Figure 2.7 Location selection criteria analysis – university campuses	55
Figure 2.8 Location selection criteria analysis – single public squares and urban parks.....	58
Figure 2.9 Location selection criteria analysis – multiple public squares and urban parks	59
Figure 2.10 Location selection criteria analysis – single public courtyards	61
Figure 2.11 Location selection criteria analysis – multiple public courtyards.....	62
Figure 2.12 The most popular criteria for selecting locations.....	63
Figure 2.13 The number of selected papers in different climate types	67
Figure 3.1 Microclimate publications in the field of built environment and design from 2012 to 2022 (The dimensions and Web of Science search results were included in this figure)	73
Figure 3.2 The number of microclimatic publications in different Köppen climate classification.....	74
Figure 3.3 Temperate oceanic (Cfb) areas around the world (Beck et al., 2018).....	76
Figure 3.4 Methodological process	78
Figure 3.5 The map of microclimatic papers in Cfb cities around the world	80
Figure 3.6 Results of microclimatic studies in London	83
Figure 3.7 Results of microclimatic studies in Melbourne	87
Figure 3.8 Results of microclimatic studies in other Cfb cities	94
Figure 3.9 Results of microclimatic studies for all selected papers.....	95
Figure 4.1 Köppen climate classification map of Australia (Peel et al., 2007).....	104
Figure 4.2 Köppen climate classification map of New Zealand (Peel et al., 2007).....	104
Figure 4.3 Population growth and density of Australia (Cameron et al., 2019).....	107
Figure 4.4 Population growth and density of New Zealand (Source: Stats NZ).....	107
Figure 4.5 Methodological process.....	109
Figure 4.6 Number of selected papers in different years for Australia and New Zealand	110

Figure 4.7 Results of microclimate and outdoor thermal comfort studies in Australia	123
Figure 4.8 Results of microclimate and outdoor thermal comfort studies in New Zealand.....	128
Figure 4.9 Results of microclimatic and outdoor thermal comfort studies for all selected papers	129
Figure 5.1 The structure of the research.....	138
Figure 5.2 The locations of Davis 6152 Wireless Vantage Pro2 weather stations	140
Figure 5.3 Scatter plot illustrating the measured and Envi-met simulated data points, along with the best fit line obtained from linear regression analysis.....	147
Figure 5.4 Density plots to compare distribution of field measurements and Envi-met simulated data in location 1 and location 2	148
Figure 5.5 The results obtained from the field measurements and Envi-met simulation for air temperature, wind speed, and humidity on March 14, 2023, for location 1 and March 15, 2023, for location 2.....	149
Figure 5.6. a: Layer of hazard for location 1, showing the distribution of thermal stress areas based on field measurements and simulations b: categorization PET level for different thermal perception in a Cfb climate (Potchter et al., 2018) c: the input data for Envi-met	150
Figure 5.7. a: Layer of hazard for location 2, showing the distribution of thermal stress areas based on field measurements and simulations b: categorization PET level for different thermal perception in a Cfb climate (Potchter et al., 2018) c: the input data for Envi-met	151
Figure 5.8 Layers of the number of people distribution (a) location 1, (b) location 2.....	152
Figure 5.9 (a): Layer of exposure for location 1, (b): Layer of exposure for location 2.....	153
Figure 5.10. Layer of vulnerability for location 1.....	154
Figure 5.11 Layer of vulnerability for location 2.....	155
Figure 5.12 Distribution of PET index for outdoor thermal sensation votes	156
Figure 5.13 Bubble plot of the relationship between respondents' thermal sensation and the physiological Equivalent (PET) index (Note: For TSV scale, -3, - 2, - 1, 0, 1, 2, and 3 represent cold, cool, slightly cool, neutral, slightly warm, warm, hot respectively).....	157
Figure 5.14 The construction of thermal risk map for location 1	158
Figure 5.15. The construction of thermal risk map for location 2	159
Figure 5.16 The PET levels and percentage for the areas with high outdoor thermal risk in location 1, depicting the years 2023(a), 2050(b), and 2080(c)	160
Figure 5.17 The PET levels and percentage for the areas with high outdoor thermal risk in location 2, depicting the years 2023(a), 2050(b), and 2080(c)	162
Figure 5.18 (a) PET levels of outdoor thermal risk area at location one under the current scenario. (b) PET levels of outdoor thermal risk area at location one under the defined scenario	165
Figure 5.19 (a) PET levels of outdoor thermal risk area at location two under the current scenario. (b) PET levels of outdoor thermal risk area at location two under the defined scenario.....	166
Figure 6.1 Wind speed pattern of Auckland New Zealand from 2000 to 2022 per month (source: https://www.wunderground.com/history/daily/nz/auckland).....	173
Figure 6.2 The structure of the research.....	177
Figure 6.3 Research location.....	178

Figure 6.4 Wind sensation based on surveys	180
Figure 6.5 The locations of Davis 6152 wireless vantage pro2 weather stations	182
Figure 6.6 Details of the CFD simulations, (number of mesh elements: 7260609).....	183
Figure 6.7 scatter plot illustrating the measured and CFD simulated data points.....	184
Figure 6.8 Modified comfort criteria based on wind speed	186
Figure 6.9 Different zones of AUT for analysing wind speed	187
Figure 6.10 Results of wind speed analysis location 1	188
Figure 6.11 Results of wind speed analysis location 2	189
Figure 6.12 Results of wind speed analysis location 3	191
Figure 6.13 Results of wind speed analysis location 4	192
Figure 6.14(a): current scenario during summer, (b):current scenario during winter, (c): mitigation scenario during summer, (d): mitigation scenario during winter, (e): risk areas, (f): current and mitigation wind speed in risk areas.....	193
Figure 6.15 (a): first scenario (increasing aspect ratio) (b): second scenario (decreasing aspect ratio, part 1) (c): second scenario (decreasing aspect ratio, part 2).....	194
Figure 7.1 The structure of the research.....	207
Figure 7.2 Research location.....	208
Figure 7.3 The results obtained from field measurements and Envi-met simulations for air temperature, wind speed, and humidity on March 14, 2023, in Location 1 and March 15, 2023, in Location 2	210
Figure 7.4 Scatter plot illustrating the measured and Envi-met simulated data points, along with the best fit line obtained from linear regression analysis.....	212
Figure 7.5 Various outdoor areas of AUT	213
Figure 7.6 (a): the outdoor thermal comfort range for summer from 2000 to 2023, (b): the outdoor thermal comfort range for winter from 2000 to 2023, (c): categorization PET level for different thermal perception in a Cfb climate (d): : the input data for Envi-met.....	214
Figure 7.7 Predicted future summer PET based on scenarios RCP 4.5 & RCP 8 .5.....	218
Figure 7.8 Predicted future winter PET based on scenarios RCP 4.5 & RCP 8.5.....	219
Figure 7.9(a): Increasing the aspect ratio by adding a level for analysing the level of PET, (b): Decreasing the aspect ratio by removing a level for analysing the PET level.....	221
Figure 7.10 (a): The PET level by current aspect ratios, (b): The PET level by increasing aspect ratios, (c): The PET level by decreasing aspect ratios, (d): Comparing the impacts of various aspect ratios on PET	222
Figure 7.11 (a): Adding trees for analysing the PET level (b): altering 50% of wall's materials with greenery for analysing the PET level.....	224
Figure 7.12 The PET level by current aspect ratios, (b) The PET level by adding trees, (c) The PET level by adding trees and green walls, (d) Comparing the impacts of various greeneries on PET	225

List of Tables

Table 1.1 The number of publications focusing on outdoor thermal comfort in different climate from 1985 to 2021 (Source: Google Scholar, Dimensions, Scopus)	15
Table 1.2 Publications on urban microclimate in New Zealand	15
Table 2.1 Climate types according to Köppen (Beck et al., 2018).....	41
Table 2.2 The list of selected papers of neighbourhoods based on Köppen climate classification and their achievements	42
Table 2.3 The list of selected papers of urban streets based on Köppen climate classification and their achievements.....	49
Table 2.4 The list of selected papers of university campuses based on Köppen climate classification and their achievements.....	53
Table 2.5 The list of selected papers of public squares and urban parks based on Köppen climate classification and their achievements.....	56
Table 2.6 The list of selected papers of public courtyards based on Köppen climate classification and their achievements	59
Table 3.1 Climate types according to Köppen (Kottek et al., 2006, Beck et al., 2018)	72
Table 3.2 The number of papers in various Cfb cities	78
Table 3.3 The number of microclimatic papers in London	80
Table 3.4 The number of microclimatic papers for Melbourne Climate.....	84
Table 3.5 The number of microclimatic papers in other Cfb cities	88
Table 4.1 Population growth and climate change in Australia and New Zealand.....	105
Table 4.2 Previous microclimate and outdoor thermal comfort papers in Australian cities	110
Table 4.3 Previous microclimate and outdoor thermal comfort studies in Melbourne, Australia.....	111
Table 4.4 Previous microclimate and outdoor thermal comfort studies in Sydney, Australia.....	115
Table 4.5 Previous microclimate and outdoor thermal comfort studies in Adelaide and Geelong, Australia.....	119
Table 4.6 Previous microclimate and outdoor thermal comfort papers in New Zealand cities	123
Table 4.7 Previous microclimate and outdoor thermal comfort studies in New Zealand	124
Table 5.1 Mean(μ) and standard deviation (σ) of field measurements and simulated data by Envi-met for Location1 (St. Paul Street) and Location2 (Hikuwai Plaza)	145
Table 5.2 Features of thermal risk areas.....	163
Table 5.3 Features of future scenarios for high thermal risk areas	164
Table 6.1 Beaufort scale (Bennett, 2007).....	175
Table 6.2 The results of CFD simulation	185
Table 6.3 Comparing the results of this study and previous studies.....	198
Table 7.1 Predicted future outdoor thermal comfort for future summers	217
Table 7.2 Predicted future outdoor thermal comfort for future winters	218

List of Appendices

Appendix A. Distribution of survey responses collected at both locations (n=347).....	302
Appendix B. A sample questionnaire.....	304
Appendix C. Relationship between Thermal sensation and responses to questions.....	304
Appendix D. Ethics approval and documents.....	308

Attestation of Authorship

I hereby declare that this submission is my own work and that, to the best of my knowledge and belief, it contains no material previously published or written by another person. Additionally, I affirm that no substantial portion of this work has been submitted for the award of any other degree or diploma from a university or other institution of higher learning.

Saghar Hashemi

24 March 2024

Co-Authored works and Declaration of Collaboration

Chapter Number:	2
Manuscript Title:	Navigating the microclimates and outdoor thermal comfort studies: A comprehensive review of location selection criteria and trends
Publication Status:	Submitted for Publication
Reference if published:	
AUTHOR SURNAME: (order as per manuscript)	CONTRIBUTION (May copy from the guidelines above)
Saghar Hashemi	responsible for writing, ideas, and the content of the research
Prof. Amirhosein Ghaffarinahoseini	provided guidance and support to improve the quality of the research
Prof. Ali Ghaffarianhoseini	provided guidance and support to improve the quality of the research
Assoc. Prof. Nicola Naismith	provided guidance and support to improve the quality of the research
Assoc. Prof. Zhihua Wan	provided expertise and advice as construction experts to support the research

Chapter Number:	3
Manuscript Title:	An assessment of existing microclimate and outdoor thermal comfort studies in temperate oceanic (Cfb) cities- A systematic review
Publication Status:	Submitted for Publication
Reference if published:	
AUTHOR SURNAME: (order as per manuscript)	CONTRIBUTION (May copy from the guidelines above)
Saghar Hashemi	responsible for writing, ideas, and the content of the research
Prof. Amirhosein Ghaffarinahoseini	provided guidance and support to improve the quality of the research
Prof. Ali Ghaffarianhoseini	provided guidance and support to improve the quality of the research
Assoc. Prof. Nicola Naismith	provided guidance and support to improve the quality of the research
Dr. Edward Halawa	provided expertise and advice as construction experts to support the research

Chapter Number:	4
Manuscript Title:	A systematic review of microclimate and outdoor thermal comfort studies in Australia and New Zealand
Publication Status:	Accepted for Publication
Reference if published:	http://dx.doi.org/10.1108%2FSASBE-10-2023-0322
AUTHOR SURNAME: (order as per manuscript)	CONTRIBUTION (May copy from the guidelines above)
Saghar Hashemi	responsible for writing, ideas, and the content of the research
Prof. Amirhosein Ghaffarinahoseini	provided guidance and support to improve the quality of the research
Prof. Ali Ghaffarianhoseini	provided guidance and support to improve the quality of the research
Assoc. Prof. Nicola Naismith	provided guidance and support to improve the quality of the research
Prof. Elmira Jamei	provided expertise and advice as construction experts to support the research

Chapter Number:	5
Manuscript Title:	Summer Outdoor Thermal Risk Area Mapping on a University Campus in Auckland, New Zealand
Publication Status:	Submitted for Publication
Reference if published:	
AUTHOR SURNAME: (order as per manuscript)	CONTRIBUTION (May copy from the guidelines above)
Saghar Hashemi	responsible for writing, ideas, and the content of the research
Prof. Amirhosein Ghaffarinahoseini	provided guidance and support to improve the quality of the research
Prof. Ali Ghaffarianhoseini	provided guidance and support to improve the quality of the research
Assoc. Prof. Nicola Naismith	provided guidance and support to improve the quality of the research
Mrs. Sahar Barmomanesh	provided expertise and advice as construction experts to support the research
Prof. David Sailor	provided expertise and advice as construction experts to support the research
Prof. Umberto Berardi	provided expertise and advice as construction experts to support the research

Chapter Number:	6
Manuscript Title:	Pedestrian-level wind speed analysis: A case study at Auckland university of technology
Publication Status:	Submitted for Publication
Reference if published:	
AUTHOR SURNAME: (order as per manuscript)	CONTRIBUTION (May copy from the guidelines above)
Saghar Hashemi	responsible for writing, ideas, and the content of the research
Prof. Amirhosein Ghaffarinahoseini	provided guidance and support to improve the quality of the research
Prof. Ali Ghaffarianhoseini	provided guidance and support to improve the quality of the research
Assoc. Prof. Nicola Naismith	provided guidance and support to improve the quality of the research
Prof. Mattheos Santamouris	provided expertise and advice as construction experts to support the research
Assoc. Prof. Hideki Kikumoto	provided expertise and advice as construction experts to support the research

Chapter Number:	7
Manuscript Title:	The impacts of historical and future climate change projections on the outdoor thermal comfort patterns of Auckland, New Zealand
Publication Status:	Submitted for Publication
Reference if published:	
AUTHOR SURNAME: (order as per manuscript)	CONTRIBUTION (May copy from the guidelines above)
Saghar Hashemi	responsible for writing, ideas, and the content of the research
Prof. Amirhosein Ghaffarinahoseini	provided guidance and support to improve the quality of the research
Prof. Ali Ghaffarianhoseini	provided guidance and support to improve the quality of the research
Assoc. Prof. Nicola Naismith	provided guidance and support to improve the quality of the research
Prof. Ayyoob Sharifi	provided expertise and advice as construction experts to support the research

Acknowledgements

I extend my deepest gratitude to my esteemed supervisors, Prof. Amirhosein Ghaffarianhoseini, Prof. Ali Ghaffarianhoseini, and Assoc. Prof. Nicola Naismith, for their unwavering support throughout this academic journey.

I am sincerely thankful to the Auckland University of Technology (AUT) for awarding me the Vice Chancellor's Doctoral Scholarship, providing me with the opportunity to conduct my research at this prestigious institution.

I would like to acknowledge the invaluable assistance of the AUTECH Secretariat for their meticulous review and approval of the ethics applications related to my questionnaire surveys. The ethics application number, 22/316, received approval on 09/02/2023. I extend my heartfelt thanks to the AUT family for their active participation in my questionnaire surveys.

Lastly, I wish to express my heartfelt appreciation to my partner for his unwavering love and support. I also extend my gratitude to my beloved sister and parents, who have been pillars of strength at every stage of my PhD journey.

Chapter 1 Introduction

1.1 Overview

Urbanization is rapidly transforming the built environment, leading to significant changes in microclimates within cities. These changes, compounded by the effects of climate change, have a direct impact on outdoor thermal comfort (OTC), a critical factor influencing the usability and livability of outdoor spaces. Understanding and optimizing thermal conditions in outdoor environments are crucial for enhancing urban residents' well-being and mitigating the urban heat island effect.

Despite growing interest in outdoor thermal comfort research, knowledge gaps remain regarding how specific urban design elements—such as street orientation, building arrangement, and greenery—interact with microclimates, especially in temperate oceanic climates like Auckland, New Zealand. This research addresses these gaps by investigating the microclimatic conditions and outdoor thermal comfort at the Auckland University of Technology (AUT) city campus.

This chapter provides an overview of the research background, discussing the importance of microclimate and outdoor thermal comfort studies. It presents the research rationale, objectives, and questions. The methods are briefly described, followed by the contribution of the research to urban design and the construction industry. Lastly, the structure of the thesis and a preview of the results are outlined.

1.2 Definition of urban microclimate and outdoor thermal conditions

Rapid urbanization in recent years has heightened the significance of outdoor thermal comfort (OTC) as a key indicator of outdoor space quality. OTC is one of the most critical aspects affecting the usability and livability of urban spaces, as it directly influences residents' well-being and the attractiveness of outdoor areas (Eusuf et al., 2014, Jamaludin et al., 2015, Li et

al., 2016). This topic has garnered increasing attention from researchers, making it a crucial focus of urban studies in the context of urbanization and climate change (Tseliou et al., 2016, Emmanuel & Steemers, 2018, Fang et al., 2019, Fabbri et al., 2020).

According to the American Society of Heating, Refrigerating and Air-Conditioning Engineers (ASHRAE), thermal comfort is defined as “the condition of mind which expresses satisfaction with the thermal environment and is assessed by subjective evaluation” (Schiavon et al., 2014). In outdoor environments, thermal comfort is influenced by a combination of climatic factors (Lau et al., 2019) such as Air Temperature (T_a), Wind Velocity (V_a), Relative Humidity (RH), and Mean Radiant Temperature (T_{mrt}) (Fang et al., 2021), and non-climatic factors, including personal characteristics like age, gender, and activity levels (Amindeldar et al., 2017, Krüger et al., 2017, Galindo & Hermida, 2018) (Figure 1.1).

The microclimatic conditions of urban spaces, including air temperature, wind speed, and solar radiation, are significantly influenced by urban form elements such as building height, street orientation, site coverage, and greenery. These factors collectively shape the microclimate and, consequently, impact both outdoor thermal comfort and the energy demand of surrounding buildings (Deng et al., 2016).

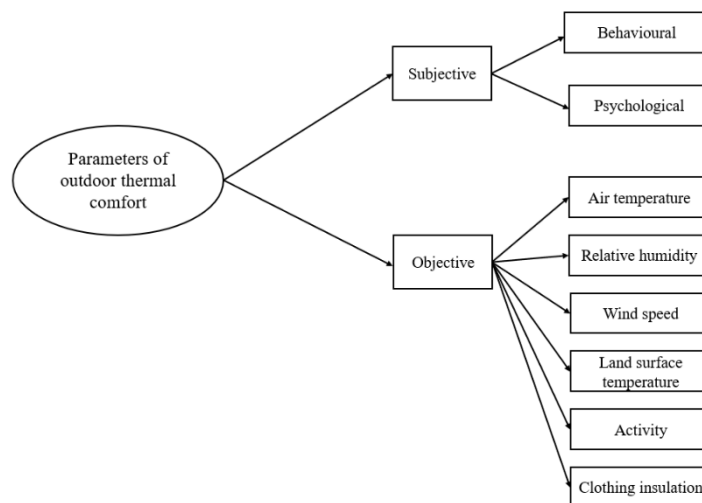

Figure 1.1 Outdoor Thermal Comfort Parameters(Das et al., 2020)

1.3 The significance of microclimate and outdoor thermal studies

More than half of the world's population today lives in cities (Salata et al., 2016), and the rate of urban population increase is 1.8 percent each year (Colunga et al., 2015). This urbanization process contributes to the urban heat island (UHI) effect, which is the phenomenon where urban areas experience higher air temperatures than surrounding rural regions due to human activities and built environments (Oke, 1982, Stewart & Oke, 2012, Taleghani et al., 2015, Bai et al., 2017, Aflaki et al., 2017). UHI has been observed in over 400 cities worldwide (Su, et al., 2021), and while it affects cities in different ways depending on local climates (Leal et al., 2021), it universally degrades outdoor thermal comfort and poses health risks to urban populations (Bai et al., 2017).

Climate change exacerbates urban overheating through rising temperatures, heatwaves, and prolonged thermal discomfort, leading to heat stress and increased mortality rates in cities (Emmanuel & Krüger, 2012, Morakinyo et al., 2017, Santamouris et al., 2017, Ashraf et al., 2019, Jamei et al., 2024). Given these trends, studies on microclimate and outdoor thermal comfort have gained substantial attention, as evidenced by over 21,000 publications across databases like Dimensions, Google Scholar, and Scopus.

1.4 The definition of thermal risk areas

Layers of hazard, exposure, and vulnerability can identify a high thermal risk location (Huang et al., 2018). Hazard indicates the potential for negative consequences in the future (Peduzzi et al., 2009), such as natural disasters caused by severe rain or extreme weather. Exposure is the inventory of elements in an area where hazard occurrences occur (Reduction, 2004). Vulnerability describes the tendency of exposed components, such as humans, to suffer negative consequences due to hazard events (Peduzzi et al., 2009). Previous research has attempted to use these factors to assess the risk in a specific area (Sara et al., 2016). The highest

thermal risk area is thus identified by superimposing the layers of the three features above and examining the overlapping area (Huang et al., 2018).

1.4.1 The layer of hazard (extreme thermal condition)

Thermal stress is considered a hazard in the context of outdoor thermal comfort. The risk of thermal stress in a particular area is assessed using outdoor thermal comfort indices, with higher index values indicating a greater risk of experiencing thermal discomfort (Huang et al., 2018).

1.4.2 The layer of exposure

Exposure is defined by the spatial intensity of space usage. Areas with higher exposure have larger numbers of people present for prolonged periods. This is measured by tracking the number of individuals and their time spent outdoors, creating a spatial and temporal map of exposure in urban spaces (Huang et al., 2018).

1.4.3 The layer of vulnerability

Vulnerability reflects the likelihood of individuals in a space experiencing negative effects due to hazardous conditions. Research shows that tourists, being less familiar with local climates, are more vulnerable to thermal stress compared to residents, who are better adapted to the environment (Lin & Matzarakis, 2008). As a result, spaces frequented primarily by tourists are considered more vulnerable, while those used mostly by residents are deemed lower-risk areas (Huang et al., 2018).

1.5 Different approaches to investigating outdoor thermal conditions

Meteorological data and occupants' actual thermal perceptions can be obtained by the investigation combining subjective and objective approaches, including on-site field measurements, site observations, a structured questionnaire, and software simulations (Huang et al., 2017).

1.5.1 Field measurements

The majority of measurements are made in the field, providing "real-world" records of the urban thermal environment (Lai et al., 2019). Throughout the case study, various in-situ measurement points will be chosen using multiple weather stations and weather measuring instruments to monitor and record each point's air temperature, air humidity, wind speed, the mean radiant temperature and globe temperature for a specific length of time. Long-term monitoring is done using a fixed meteorological station (Johansson & Emmanuel, 2006), and meteorological stations can only record parameters of the thermal environment in a restricted number of spaces (Srivanit & Hokao, 2013, Lai et al., 2019). Different sensors and data loggers are employed for short-term measurements to capture the urban climate mobile measurements (Voogt & Oke, 2003, Kong et al., 2012, Klemm & Lin, 2016, Yilmaz et al., 2021).

1.5.2 Field surveys

The impression of outdoor thermal conditions influences people's outdoor behaviour (Nikolopoulou et al., 2001, Thorsson et al., 2004, Eliasson et al., 2007). To explore the impact of urban geometry and hence urban microclimate on pedestrian comfort, a questionnaire survey will be conducted alongside physical measurements (Sharmin et al., 2015, Sharmin et al., 2019). Questionnaire surveys are used to collect demographic, clothing, and activity data, as well as to assess the individuals' thermal perceptions (Shen et al., 2017).

1.5.3 Software simulations

Field measurements have been used to investigate the impact of urban design on urban microclimate (Lai et al., 2019). However, due to the limitations of the observational approach, their findings could only reflect the current condition in a specific time and space. The simulation approach has been used in studies to examine the impact of various urban designs on urban microclimate and outdoor thermal comfort in order to develop future climate-sensitive

urban design (Montazeri et al., 2017). In recent years, researchers and designers have become more interested in modelling microclimates; understanding the modelling capabilities and constraints of tool applicability has become critical (Naboni et al., 2017). Users can get critical microclimate performance indicators including air temperature (Ta), mean radiant temperature (MRT), relative humidity (RH), predicted mean vote (PMV), and wind speed from microclimate simulation programs (Albdour & Baranyai, 2019). The comparison of different CFD software for wind modelling reveals significant discrepancies. There is no single market-leading software at this time. Thus, one must select software based on prior expertise and project-based objectives (Brook-Lawson & Holz, 2020). The spatial and temporal distribution of microclimate cannot be adequately demonstrated using a single simulation tool (Hwang et al., 2018).

In the Figure 1.2, the similarities and differences of different software simulations are illustrated, As ANSYS, Autodesk CFD, and Meteodyn do not support any outdoor thermal indices; they are excluded from our research. Although Ryman would be a good software for calculating outdoor thermal comfort, this software cannot calculate wind speed and direction; therefore, we cannot select Ryman. Building form and shapes are limited in CitySim pro, and this software cannot support common outdoor thermal indices such as TAS, Ladybug and Honeybee; therefore, this software is excluded.

Detailed comparison of CFD software serving the scope of the research (General criteria and Specific outputs)

Choosing Criteria	RayMan	Envi-met	ANSYS	Autodesk® CFD
General criteria				
User Interface	Friendly	Friendly	Extremely Complex	Friendly
Reliability & Accuracy	High	High	Very High	High
Cost	Free	Low	Very High	Free
Operating System	Windows	Windows	Windows and MAC	Windows
Compatibility	Low	Moderate	High	Very High
Visualization and Graphics	Moderate	High	High	High
Comfort Prediction Index	PET	PMV	-	-
Specific Outputs				
PMV	Yes	Yes	No	No
PET	Yes	Yes	No	No
PDD	Yes	Yes	No	No
MRT	Yes	Yes	Yes	Yes
Relative Humidity	Yes	Yes	Yes	No
Air Temperature	Yes	Yes	Yes	Yes
Wind Speed	No	Yes	Yes	Yes
Wind Direction	No	Yes	Yes	Yes
Solar Radiation	Yes	Yes	Yes	Yes
Sky-view Factor	Yes	Yes	Yes	Yes
CO ₂	No	Yes	Yes	Yes

Detailed comparison of CFD software serving the scope of the research (Strategies and elements can be investigated by the tool in outdoor environment)

Strategies and elements can be investigated by the tool in outdoor environment				
	Yes	Yes	No	No
Plantation	Yes	Yes	No	No
Materials and Albedo	Yes	Yes	Yes	No
Waterbody	No	Yes	Yes	Limited
Green Roofs	No	Limited	Limited	Limited
Green Walls	No	Limited	Limited	Limited
Shading	Yes	Yes	Yes	Yes
Streets Canyon Geometry	No	Yes	Yes	Yes
Streets Wind Orientation	No	Yes	Yes	Yes
Building Form and Shape	No	Limited	Yes	Yes
Buildings Height	Limited	Yes	Yes	Yes
Site Landform	No	No	Yes	Yes
Heat Sinks	No	Yes	Yes	Yes
Urban Form	Limited	Yes	Yes	Yes
Building Adjacency	Limited	Limited	Yes	Yes
Buildings Arrangement	Limited	Yes	Yes	Yes
Building Envelope	No	No	Yes	Yes
Building Roof Shape	No	No	Yes	Yes
Natural Ventilation	No	Limited	Yes	Yes
Inducers, Shafts, Projections, Double Skin Façade				
Final Results	Excluded	Chosen	Excluded	Excluded

Detailed comparison of CFD software serving the scope of the research (General criteria and Specific outputs)

Choosing Criteria	CitySim Pro	TAS	Metodyn	Ladybug and Honeybee
General Criteria				
User Interface	Friendly	Friendly	Friendly	Friendly
Accuracy	moderate	High	Moderate	Very High
Cost	Free	Low	Low	Free
Operating System	Online	Windows	Windows	Windows and mac and Linux
Compatibility	Low	High	Moderate	Very High
Visualization and Graphics	Moderate	High	High	High
Comfort Prediction Index	PET	PDD	No	SET
Specific Outputs				
PMV	No	No	No	No
PDD	No	Yes	No	No
PET	Yes	No	No	No
MRT	Yes	Yes	No	Yes
Relative Humidity	No	Yes	No	No
Air Temperature	Yes	Yes	Yes	Yes
Wind Speed	Yes	Yes	Yes	Yes
Wind Direction	Yes	Yes	Yes	Yes
Solar Radiation	Yes	Yes	No	Yes
Sky-View Factor	Yes	Yes	No	Yes
CO ₂	No	Yes	No	No

Detailed comparison of CFD software serving the scope of the research (Strategies and elements can be investigated by the tool in outdoor environment)

Strategies and elements can be investigated by the tool in outdoor environment				
Plantation	No	No	No	Yes
Materials and Albedo	No	Yes	No	Yes
Waterbody	No	No	Yes	No
Green Roof	No	No	No	Yes
Green Wall	No	No	No	Yes
Shading	Yes	Yes	Yes	Yes
Streets Canyon Geometry	Yes	Yes	Yes	Yes
Streets Wind Orientation	Yes	Yes	Yes	Yes
Building Form and Shape	Limited	Yes	Yes	Yes
Buildings Height	Yes	Yes	Yes	Yes
Site Landform	No	Yes	Yes	Yes
Heat Sinks	Yes	Yes	Yes	No
Urban Form	Yes	Yes	Yes	Yes
Building Adjacency	Yes	Yes	Yes	Yes
Buildings Arrangement	Yes	Yes	Yes	Yes
Building Envelope	Limited	Yes	No	Limited
Building Roof Shape	Yes	Yes	No	Yes
Natural Ventilation	Limited	Yes	Limited	Limited
Inducers, Shafts, Projections, Double Skin Façade				
Final Results	Excluded	Excluded	Excluded	Excluded

Figure 1.2 Differences and similarity between different software (Albdour & Baranyai 2019)

According to the previous papers, Envi-met software is the most appropriate compared to other tools for calculating outdoor variables (Albdour & Baranyai, 2019). The results suggest that ENVI-met's serious flaw is its inability to input sun radiation hourly in its current version, which can have an impact on the simulation's temperature environment. ENVI-met tended to overestimate the leaf surface temperature and underestimate the vapour flux for the tree model's physiological parameters, especially at midday in summer. One of the key explanations could be the tree model's simpler calculation. Furthermore, for each microclimate variable, the thermal influence of trees, that is, the differences between surrounding treeless sites and shaded areas, was completely underestimated in ENVI-met (Liu et al., 2018).

1.5.4 Outdoor thermal indices

Thermal indices based on the human body's energy balance measure the physiological component of thermal comfort, considering basic Thermo-physio regulatory processes such as peripheral blood vessel constriction or dilation and physiological sweat rate (Martinelli & Matzarakis, 2017). For analysing the thermal comfort state of outdoor places, many indicators integrate thermal comfort elements with human heat balance (Hwang et al., 2018). Only four

of the 165 human thermal indices developed (PET, PMV, UTCI, and SET*) appear to be widely used for outdoor thermal perception studies (Potchter et al., 2018). PET (The Physiologic Equivalent Temperature), PMV (Predict the mean value of votes), and UTCI (Universal Thermal Climate Index) are the three most commonly used indices, and they all have the same characteristics: they are universal indices that can be used in both cold and hot thermal conditions, they cover a wide range of thermal sensation or stress classification, and they have 7 to 10 categories. Other indices, such as SET*(Standard Effective Temperature), THI (Temperature Humidity Index), WBGT (Wet-bulb globe-temperature), and OUTSET*, are designed for hot areas and encompass a small range of thermal sensations, ranging from mild to very hot (Potchter et al., 2018). Calculating thermal indices (e.g. PET) using meteorological factors and then comparing them to data from questionnaires to gain exact information on inhabitants' temperature perception (Lin & Matzarakis, 2008, Herrmann & Matzarakis, 2012, Ketterer & Matzarakis, 2014). Figure 1.3 shows the number of previous studies that used different thermal indices.

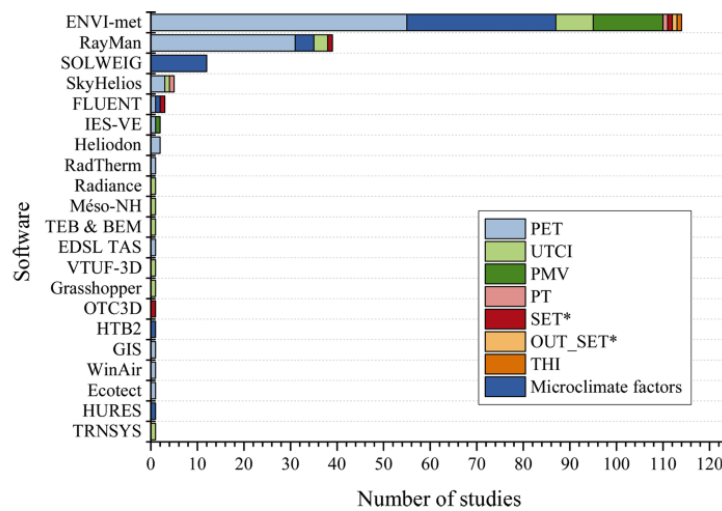

Figure 1.3 Previous number of studies that used different thermal indices (Lam et al., 2021)

1.6 The parameters which influence outdoor thermal conditions

Different variables affect microclimate conditions and human thermal comforts in the outdoor environment, Such as urban geometry (Jamei et al., 2016), the amount of vegetation and water bodies (Lai et al., 2019, Lam et al., 2021), materials of building surfaces (Gaitani et al., 2014) and natural ventilation (Tablada et al., 2009, Jomehzadeh et al., 2020). This section discusses in detail the most common variable factors, namely geometry, vegetation, and material.

1.6.1 Geometry

Urban open areas can be characterized by different geometric configurations, such as the arrangement of buildings, street layouts, and the spacing between structures (Lai et al., 2019). The fundamental impact of urban geometry on the urban thermal environment is that it alters radiative and convective heat exchange in urban open spaces (Krüger et al., 2011, Jamei et al., 2016). Solar radiation is often blocked by dense urban morphology, which also affects wind speed (Emmanuel & Johansson, 2006, Xu et al., 2019). Aspect ratios, street orientations, and sky view factors are commonly used to quantify urban geometry in thermal environment research (Jamei et al., 2016).

1.6.1.1 Aspect ratio

The aspect ratio is defined as the ratio between the average height (H) of the canyon and the canyon width (W), is one of the most important criteria in establishing canyon geometry (Oke, 1988, Ali-Toudert & Mayer, 2006, Gromke & Ruck, 2012). The canyon is uniform if the aspect ratio is equal to 1 (with no noticeable openings on the walls), shallow if the aspect ratio is less than 0.5, and deep if the aspect ratio is greater than 2 (Ahmad et al., 2005, Jamei et al., 2016).

1.6.1.2 Street orientation

Street orientation is one of the most important factors in determining solar access and wind speed in urban canyons, and it has a significant impact on sidewalk thermal comfort (Johansson

& Emmanuel, 2006, Andreou, 2013). The issue of solar access in blocked and densely built-up areas has been addressed by a number of authors (Littlefair, 1998, Yu et al., 2009, Gago et al., 2013, Garcia-Nevado & Coch, 2016). As well as the preferred street orientation for different geographical locations (Jamei et al., 2016, Jamei & Rajagopalan, 2019). When compared to N–S oriented streets, the majority of research on the effect of street orientation on thermal comfort determined that E–W oriented streets have the worst thermal conditions during the day. E–W oriented streets also have a longer time of solar exposure throughout the summer (Qaid & Ossen, 2015, Jamei et al., 2016, Wang et al., 2016, Jamei & Rajagopalan, 2019, He et al., 2020).

1.6.1.3 Sky view factor

"The ratio of the proportion of sky that can be seen from a given place on a surface to that potentially available" is how Sky View Factor (SVF) is defined (Yuan & Chen, 2011, Yang et al., 2013, Chatzipoulka et al., 2018). The level of view toward the sky is defined by the level of urban obstructions, such as buildings and vegetation (Voogt & Oke, 2003, Jamei et al., 2016, Masson et al., 2020). SVF is a crucial metric in determining the geometry, density, and thermal balance of urban environments. The heat island effect is generated and controlled by this parameter, which is a dimensionless value between 0 and 1 (Jamei et al., 2016, Yin et al., 2018). Because of obstructions in the urban sky vault, SVF in urban areas is always less than 1 (Yuan & Chen, 2011, Xi et al., 2012, Jamei et al., 2016).

1.6.2 Vegetation

Apart from the aesthetic benefits, trees and other vegetation in urban contexts assist in alleviating the effects of the urban heat island by increasing the latent heat flux through evapotranspiration and decreasing the sensible heat flux through shading, resulting in lower air temperatures (Feyisa et al., 2014, Li & Norford, 2016). Increased urban greenery is closely

linked to better thermal comfort, especially during heat waves (Salata et al., 2017, Sodoudi et al., 2018). Thus, increasing the amount of vegetation in cities is one of the most important ways to reduce air and radiative temperatures while improving thermal comfort through shading and transpiration. Vegetation, like buildings, suppresses short-wave radiation and slows the wind (Cortês, 2013). Furthermore, vegetation can lower air temperature through transpiration. Long-wave radiation can be minimized in outdoor environments by using a lawn or green wall to lower the surface temperature (Wong et al., 2003, Shashua-Bar et al., 2011, Sheweka & Magdy, 2011). In high-density cities, the most important vegetation effect is to minimize heating in urban canyons by reducing solar radiation absorption through shading and evapotranspiration (Gago et al., 2013, Duarte et al., 2015). Plants can help reduce ambient air temperature in a variety of ways, including urban parks, road trees, the environment around buildings, and rooftop gardens. Furthermore, rooftop gardens or vertical gardening could help to lower surface temperatures (Givoni, 1991, Duarte et al., 2015, Ali & Patnaik, 2019).

1.6.3 Material

The thermal and radiative qualities of urban surfaces are determined by the composition of the urban fraction (for example, the percentage of wood, brick, and stone in walls and the percentage of asphalt shingle, ceramic tile, and wood shingle in roofs) (Jackson et al., 2010, Tornay et al., 2017, Garuma, 2018). Cool materials have been extensively researched as a means of improving the outdoor thermal environment; the materials can be used on the ground or on the building exterior surfaces, such as cool roof coatings, permeable pavements (Rosso et al., 2018, Tsoka et al., 2018, Tsoka et al., 2020). They absorb less solar radiation due to their thermophysical qualities, resulting in less heat storage and lower surface temperatures (Abu-Hamdeh & Alnefaie, 2019). Cool materials, which have a high solar reflectivity and infrared emittance, are thought to be a solution for reducing urban heat islands (Zinzi & Agnoli, 2012, Rossi et al., 2014). Cool roofs, cool asphalts and pavements, and coupled cool envelope facades

and cool ground surfaces are among the three subcategories of simulated cool materials situations (Akbari & Kolokotsa, 2016, Tsoka et al., 2018, Tsoka et al., 2018).

Reflective surfaces absorb less sunlight and so have a cooler surface temperature than typical surfaces (Synnefa et al., 2011, Qin et al., 2016). As a result, a cool surface emits less longwave radiation than ordinary materials, and the surrounding air temperature is lower (Künzel et al., 2002, Ali-Toudert & Mayer, 2007). However, some simulation studies have shown that the increase in reflected solar radiation by reflective surfaces surpasses the reduction in longwave radiation, reducing pedestrian thermal comfort (Morakinyo et al., 2017, Lai et al., 2019). Natural or artificial materials with high solar radiation reflectivity are used on the facades and roofs of buildings, as well as the pavements of urban spaces, to counteract the impacts of an urban heat island (Akbari & Kolokotsa, 2016, Pigliautile et al., 2020).

1.7 Rationale and Significance of the Study

1.7.1 Projections for future population growth in Auckland, New Zealand

Based on the Auckland city council, Auckland has a population of 1.66 million people, which is anticipated to increase by 720,000 to 2.4 million in the next 30 years. Therefore, Auckland requires a specific urban development strategy which serves as Auckland's Future Development plan. According to Auckland city council 2017, this development will be focused on existing and new urban areas. Improving the life quality in existing and new locations is one of the key factors in a successful urban development strategy, and outdoor thermal comfort conditions are determined as a critical matter for creating high-quality outside environmental design (Huang et al., 2018). Furthermore, creating comfortable urban areas through climate-responsive attitudes (Wang et al., 2018) and the impacts of urban form on outdoor thermal comfort (Yigitcanlar & Lönnqvist, 2013, Fahmi et al., 2014, Sidawi et al., 2014, Taleghani et al., 2015, Long & Wu, 2016, Yu et al., 2020) plays an important role in creating pleasant

outdoor areas. Despite this, in Auckland's future urban development plan, there is an obvious gap between the correlation of urban expansions and the impact of outdoor thermal conditions on enhancing well-being and satisfaction of people in urban context.

1.7.2 Future climate change projections in Auckland, New Zealand

Based on the national institute of water and atmospheric research (Niwa), New Zealand enjoys a moderate and temperate climate. Auckland is a major city in New Zealand, summers tend to be warm and humid, while winters are relatively mild. Rainfall is prevalent throughout the year. The majority of Auckland gets roughly 2000 hours of strong sunlight every year. Both average and maximum temperatures are likely to climb as the phenomenon of climate change, and the frequency of hot days in Auckland, New Zealand, is expected to rise (Mullan et al., 2016, Jalali et al., 2024). Temperatures are projected to increase in the future (Figure 1.4), and extreme weather events - such as heatwaves and extremely high temperatures - are also likely to become more common (Eames, 2017). Days with temperatures above 25 °C is anticipated to rise by 40 to 100 percent before 2040, and from 40 to 300 percent by 2090 (Mullan et al., 2016). In essence, Aucklanders will face three months of extra hot days, significantly increasing the risk of heat-related morbidity and mortality (Eames, 2017, Mannetje et al., 2018). Extreme heat events pose a significant threat to the health and well-being of Auckland's population (Joynt & Golubiewski, 2019), particularly for those who are either more sensitive to heat or have less capacity to adapt to their surroundings (Glover et al., 2017, Joynt & Golubiewski, 2019). As a result of future climate change, urban planners and architects should concentrate on analysing microclimate conditions, filling knowledge gaps, and designing a guideline for improving outdoor thermal conditions in Auckland, which is New Zealand's largest and most populous city.

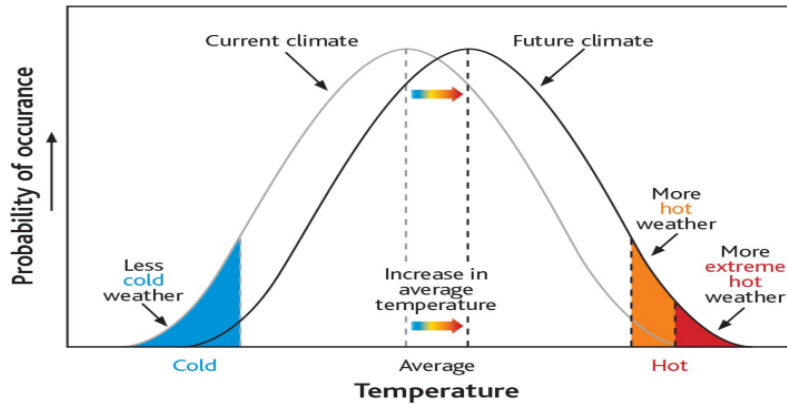

Figure 1.4 Future climate prediction of Auckland (Davidson et al., 2020)

1.7.2.1 Auckland's climate plan

In December 2020, the New Zealand government announced a climate emergency, and the country is on track to achieve net-zero emissions by 2050. The Auckland Climate Strategy is critical for achieving a zero-emissions, resilient, and healthier region that is more environmentally integrated and capable of thriving in the face of constant change and disruption (Davidson et al., 2020). Based on the Auckland city council, their core goals are:

1. To cut greenhouse gas emissions by half by 2030 and to attain net-zero emissions by 2050
2. To prepare for the effects of climate change by ensuring that they plan for the changes that will occur as a result of our present emissions trajectory (Davidson et al., 2020).

As the priorities of Auckland's climate plan, focusing on the built environment plays a vital role in adapting to climate change. Therefore, architects and urban designers should take responsibility not only in reducing the emissions in buildings but also in designing based on climate trends trying to decrease the impacts of urban designs on accelerating climate change. For this aim, microclimatic studies in the urban context play an important role in Auckland's climate plan.

1.7.3 The number of studies that have been focused on "maritime climate" and "mild climate" are limited

According to the Google Scholar, Dimensions, and Scopus, a limited number of studies have focused on microclimate and outdoor thermal conditions in a mild and maritime climate. However, based on climate change trends and urban heat island effects throughout the world, it is necessary to examine outdoor thermal conditions worldwide. In Table 1.1, the number of previous research publications in a different climate is illustrated.

Table 1.1 The number of publications focusing on outdoor thermal comfort in different climate from 1985 to 2021 (Source: Google Scholar, Dimensions, Scopus)

Climate:	The number of publications:
Hot and humid	327
Humid	311
Hot	155
Cold	147
Hot and Dry	140
Mild	35
Maritime	16

1.7.4 A limited number of studies focus on outdoor thermal conditions in New Zealand, specifically in Auckland

There are a limited number of studies on the urban microclimate in New Zealand. Previous research has only looked at a small number of cities in New Zealand (Table 1.2). The numerical models utilized are oversimplified and lack the precision accuracy to make decisions. Overall, these studies highlight the need for more research on the urban microclimate in New Zealand.

Table 1.2 Publications on urban microclimate in New Zealand

Reference	Study area	Study focus
-----------	------------	-------------

(Tuller, 1980)	Christchurch	Thermal bioclimatic effects
(Tapper et al., 1981)	Christchurch	Urban heat island
(Spronken-Smith et al., 2006)	Christchurch	Energy storage fluxes
(Chambers & Griffiths, 2008)	Australia and New Zealand	Extreme temperature
(Boretti & Watson, 2011)	New Zealand	Temperature rise analysis
(Nouri, 2015)	Auckland	Thermal Sensitive Urban Design- UHI
(Tavares et al., 2019)	Christchurch	Microclimate and urban comfort
(Perera et al., 2020)	Christchurch	Outdoor Thermal comfort and adaptation

1.7.5 Undeniable impact of outdoor thermal conditions on user's wellbeing, satisfaction, and quality of life

The significance of well-designed open spaces in enhancing quality of life has gained increasing recognition, especially in the context of rapid urbanization and the challenges posed by climate change (Klemm et al., 2015). Outdoor thermal comfort (OTC) emerges as a critical variable influencing the quality of life and livability of urban environments (Golasi et al., 2018, Zhao et al., 2018). As cities face rising temperatures and more frequent extreme weather events due to climate change, the role of OTC in public spaces becomes even more vital. The ability of these spaces to provide comfort—through acceptable temperature conditions—determines not only user satisfaction but also their resilience against climate impacts (Soares et al., 2021). In a liveable city, meeting outdoor thermal comfort needs is essential, particularly in light of the urgency to reduce global temperatures by 1.5°C as outlined in international agreements like the Paris Agreement. As urban areas expand, it is crucial to align development strategies with emission reduction goals to mitigate the impacts of climate change (Altunkasa & Uslu, 2020). Increasing the comfort of urban environments can enhance walkability and overall livability, contributing to better public health and well-being. The environmental performance of neighbourhoods significantly affects the health of urban populations, particularly as we

navigate the dual challenges of population growth and climate resilience (Lau et al., 2018). Moreover, integrating comfort with health is increasingly recognized as a key to defining well-being in the built environment (Bluyssen, 2010). New design priorities must therefore include improved health and well-being, reduced heat and cold stress, and increased comfort in line with New Zealand's decarbonization plan. Addressing these factors will not only foster sustainable urban development but also create resilient communities capable of thriving amid climate uncertainties (Albdour & Baranyai, 2019).

1.8 Research aim

The overall aim of this research is to conduct a comprehensive analysis of the microclimate and outdoor thermal comfort conditions specifically in the Central Business District (CBD) of Auckland, New Zealand. The main objectives are:

- 1) Identify previously investigated locations in microclimate and outdoor thermal comfort studies and delineate the key criteria that have guided these selections.
- 2) Review existing studies conducted in cities with climates similar to Auckland, New Zealand, to gain insights applicable to this research context.
- 3) Assess prior research specifically within the contexts of Australia and New Zealand to identify significant factors necessitating further investigation into microclimate and outdoor thermal comfort.
- 4) Identify outdoor thermal risk areas by developing hazard, exposure, and vulnerability layers.
- 5) Understand the influence of the most challenging climate factor, namely wind speed, on pedestrians' thermal comfort.
- 6) Investigate outdoor thermal comfort conditions using historical data, current observations, and predicted future climates.

1.8.1 Objective 1: location selection criteria and trends in previous microclimate and outdoor thermal comfort research

Identifying an appropriate location is emphasized as a key component of microclimate and outdoor thermal comfort studies. However, the lack of readily available guidelines to support the selection of case study locations complicates a unified approach towards such matters. This objective explores the most prominent locations of previous microclimatic and outdoor thermal comfort studies by recognizing the range of criteria considered for selecting locations. The findings of this objective are anticipated to be utilized as guidelines for selecting locations for future studies.

As a result, three research questions are expected to be answered to achieve this objective, including:

- 1) Which locations have been identified as the most widely used in previous microclimate and outdoor thermal comfort studies?
- 2) How can locations be categorized into single or multiple ones based on the Köppen climate classification?
- 3) What are the achievements and recommendations for improving microclimate and outdoor thermal comfort conditions for each category?
- 4) What is the range of criteria considered for selecting case studies in previous research on microclimate and outdoor thermal comfort?

1.8.2 Objective 2: An assessment of existing microclimate and outdoor thermal comfort studies in temperate oceanic (Cfb) cities

Based on the Köppen climate classification, Auckland has a Cfb climate, characterized by a temperate oceanic or maritime climate with mild to warm summers and cool to cold winters

(Jalali et al., 2022). This classification raises concerns in light of population growth, potential urban expansions, and the urban heat island (UHI) effect. To address these issues, a deeper understanding of microclimatic and outdoor thermal comfort conditions in various Cfb cities is necessary to compare their achievements and recommendations for facing challenges with Auckland. This objective critically examines previous urban microclimatic studies in Cfb cities, aiming to analyse past research, highlight gaps in the study of urban microclimate, and provide recommendations for neglected but crucial aspects for future studies. Urban planners and those responsible for developing climate change policies in Cfb regions will gain an improved understanding of the impact of urban microclimate from the findings.

As a result, three research questions are expected to be answered to achieve this objective, including:

- 1) What is the current overview of existing studies on urban microclimate and outdoor thermal comfort in Cfb cities?
- 2) What are the identified gaps in urban microclimate studies within Cfb cities?
- 3) What recommendations are proposed for addressing neglected but critical aspects of urban microclimate in future studies within Cfb cities?

1.8.3 Objective 3: Analysing previous microclimate and outdoor thermal comfort studies in Australia and New Zealand

The examination of microclimate and outdoor thermal comfort in Australia and New Zealand is an emerging field, but there is currently a lack of adequate research in these regions. Due to the distinct climates in these countries, findings from studies conducted elsewhere may not directly apply. Therefore, it is essential to conduct research specifically tailored to the unique climatic conditions of Australia and New Zealand to ensure precision and relevance. This study aims to assess existing studies in these countries, establish a foundation for future research,

identify gaps in current knowledge, and draw attention to areas that require further exploration. The identified research gaps are intended to shape the development of a comprehensive guideline for future studies in Australia and New Zealand, offering architects and urban designers key considerations for improving outdoor thermal conditions in their designs.

As a result, three research questions are expected to be answered to achieve this objective, including:

- 1) What is the analysis of previous research on urban microclimate and outdoor thermal comfort in Australia and New Zealand?
- 2) What gaps have been identified in studies on outdoor thermal comfort and urban microclimate in Australia and New Zealand?
- 3) What recommendations are proposed for addressing neglected but critical aspects of urban microclimate in future studies within Australia and New Zealand?

1.8.4 Objective 4: Identify outdoor thermal risk areas

Outdoor thermal risk areas result from the combination of high thermal stress and intense human presence. The significance of this objective becomes more apparent when considering the warnings of predicted climate change and global population growth. It is crucial to pinpoint the areas within cities that pose the highest risk due to both high thermal stress and human intensity. In greater detail, certain areas may experience high levels of outdoor thermal stress, but they are rarely utilized and do not warrant improvement. Thus, this objective sets out to identify outdoor thermal risk areas based on overlying three different layers (high hazard areas, high exposure areas, high vulnerability areas) and specific methodologies for each layer, which can be applied in future studies for various locations.

As a result, four research questions are expected to be answered to achieve this objective, including:

- 1) What are the best ways to define the three different layers of hazard, exposure, and vulnerability?
- 2) Which methods should be used to determine the specific layers of hazard, exposure, and vulnerability?
- 3) What future scenarios can be derived based on the predicted climate change in high thermal risk areas?
- 4) What improvement scenarios can help alleviate thermal stress in high thermal risk areas?

1.8.5 Objective 5: Analysing the impact of wind speed, on the pedestrian level of comfort

Wind speed plays a critical role in analysing human comfort within urban environments. Although Auckland, New Zealand experiences relatively high average wind speeds, there is a research gap regarding the analysis of the urban context on wind comfort within this city. Therefore, this objective aims to analyse wind speed and wind comfort criteria at the pedestrian level by defining modified comfort criteria based on wind speed. The goal is to incorporate advanced analytical methods, devise practical solutions for urban issues, and approach user experiences comprehensively. The aim is to expand methodologies and insights, offering relevant knowledge to enhance the optimization of urban environments in various cultural and geographical contexts.

As a result, four research questions are expected to be answered to achieve this objective, including:

- 1) What are the public perceptions of wind speeds during both summer and winter?

- 2) What is the average wind speed, based on historical data, in micro-scale urban areas using computational fluid dynamics?
- 3) What are the impacts of urban design elements, namely street orientations, aspect ratios, and building arrangements, on wind speed at the pedestrian level?
- 4) How can we design a comfort criteria based on wind speed for specific locations to assess the level of pedestrian comfort under different wind speed conditions?

1.8.6 Objective 6: Analysing the impacts of historical and future climate change projections on the outdoor thermal comfort patterns of Auckland, New Zealand

While Auckland, New Zealand, currently experiences a moderate climate, projections based on various Representative Concentrations Pathways (RCPs) suggest a significant future warming trend for the city (Jalali et al., 2022). Analysing outdoor thermal comfort patterns and understanding the influence of urban contexts on microclimates are vital to mitigate potential adverse impacts on future thermal comfort, enhance climate adaptation, and improve the health and well-being of residents. The insights gained from this objective can guide the implementation of strategies aimed at improving human comfort, considering anticipated climate change scenarios. Such initiatives have the potential to enhance the overall liveability of outdoor spaces within urban areas.

As a result, three research questions are expected to be answered to achieve this objective, including:

- 1) How can outdoor thermal comfort patterns be analysed based on historical data of Auckland for both summer and winter?

2) What are the projected future thermal comfort patterns for Auckland in the near future (2040), mid-future (2090), and far future (2110) based on RCP 4.5 and RCP 8.5, considering both summer and winter?

3) What are the various mitigation scenarios that can be defined to decrease thermal discomfort?

1.9 Research contribution

This research contributes to the field by achieving specific objectives that enhance the understanding of microclimate and outdoor thermal comfort in the context of Auckland, New Zealand. The key contributions of this research include:

Development of a Microclimate Assessment Model: A comprehensive model that integrates historical climate data, current observations, and predictive climate scenarios to evaluate microclimate conditions in urban areas.

1. Guidelines for Urban Design: Practical guidelines for urban planners and designers that outline strategies for optimizing urban geometry, vegetation placement, and material selection to improve outdoor thermal comfort.
2. Identification of Thermal Risk Areas: A framework for identifying and mapping outdoor thermal risk areas based on layers of hazard, exposure, and vulnerability, facilitating targeted interventions in urban planning.
3. Strategies for Climate Adaptation: Recommendations for adapting urban environments to mitigate the effects of extreme weather conditions, particularly focusing on wind speed and its impact on pedestrian comfort.
4. Data-Driven Insights for Future Studies: A comprehensive review of existing studies in similar climates, providing a foundation for future research initiatives aimed at enhancing urban sustainability and resilience.

Through these contributions, this research aims to guide urban planning and climate adaptation efforts, ensuring the creation of more comfortable and sustainable urban environments.

1.10 Research method

This study adopts a mixed methods approach, combining qualitative and quantitative data. To be more precise, the field surveys, field measurements, and software simulations in this research used a quantitative approach for gathering data that can be numerically analysed and statistically summarized. Field observations were conducted using a qualitative approach to gather descriptive data about human preferences. Field measurements were conducted in March 2023.

1.10.1 Field surveys

Individuals exhibit diverse perceptions of thermal comfort, leading to variations in their durability and vulnerability to thermal stress (Lin & Matzarakis, 2008, Huang et al., 2018). To assess the vulnerability of people in this research, a questionnaire was employed. Due to resource limitations, it was not possible to collect data from every individual present at the locations. However, efforts were made to conduct questionnaires with as many participants as feasible. To ensure a representative sample, participants of different genders and ages were selected.

The questionnaires encompassed inquiries about participants' subjective thermal sensations, their perception of comfort, and their preferences regarding environmental factors such as humidity, wind speed, and air temperature. Moreover, relevant physical attributes including age, gender, clothing type, and level of activity were recorded to understand the relationship between thermal preference and participants' characteristics.

1.10.2 Field observations

To understand people's preferences and their adaptation to the location, they were observed to identify their preferred gathering spots and popular walking paths. Additionally, the physical features of these areas were analysed to discern how people choose outdoor locations for use (Kyle et al., 2004).

1.10.3 Field measurements

Field measurements were conducted to observe meteorological data values using the Davis 6152 Wireless Vantage Pro2 weather station. The Vantage Pro2 employs high-quality sensors designed to provide accurate and reliable measurements of temperature, humidity, wind speed, direction, and rainfall (Oberascher et al., 2022). The sensors used in the Vantage Pro2 are accurate to within ± 0.5 °C for temperature, $\pm 2\%$ for relative humidity, ± 2.2 km/h for wind speed, and $\pm 5\%$ for rainfall.

1.10.4 Software simulations

To assess the risk associated with thermal stress, the research utilized the Physiological Equivalent Temperature (PET) index. The PET index serves as a metric for evaluating the level of thermal risk present in a specific location (Höppe, 1999, Blazejczyk et al., 2012). Higher PET values indicate a greater degree of thermal risk within the examined area (Huang et al., 2018). The results derived from PET prove beneficial for comparative studies involving diverse spatiotemporal variations, given the prevalence of its usage in several studies- (Chen & Matzarakis, 2018).

Envi-met is the first software which was employed to model the complete thermal environment in this research, a capability that has been affirmed through numerous research endeavours demonstrating its efficacy in replicating neighbourhood-scale thermal conditions (Shinzato et al., 2019, Lachapelle et al., 2022). Envi-met is a three-dimensional microclimatic model with

a one-dimensional boundary model, three-dimensional atmospheric model, soil model, and plant model (Chatzinikolaou et al., 2018, Rui et al., 2019). The second software which employed in this research is Ansys Fluent as our Computational Fluid Dynamics (CFD). Ansys Fluent is a computational fluid dynamics (CFD) software suitable for modelling various fluid flow phenomena, including wind speed in urban areas (Mirzaei & Carmeliet, 2013). In ANSYS, a high-quality mesh is crucial for accurate simulations, allowing the capture of urban area details. The boundary conditions for simulation encompass specifying inflow conditions (wind speed, direction, turbulence properties), where turbulence significantly affects urban airflow (Pantusheva et al., 2022). Envi-met was chosen due to its comprehensive modelling capabilities for neighbourhood-scale thermal conditions (Shinzato et al., 2019), while Ansys Fluent was selected for its precision in simulating wind speed in urban areas (Mirzaei & Carmeliet, 2013).

Figure 1.5 shows the research framework designed with clear objectives and methods to guide the research efforts, which is described as follows:

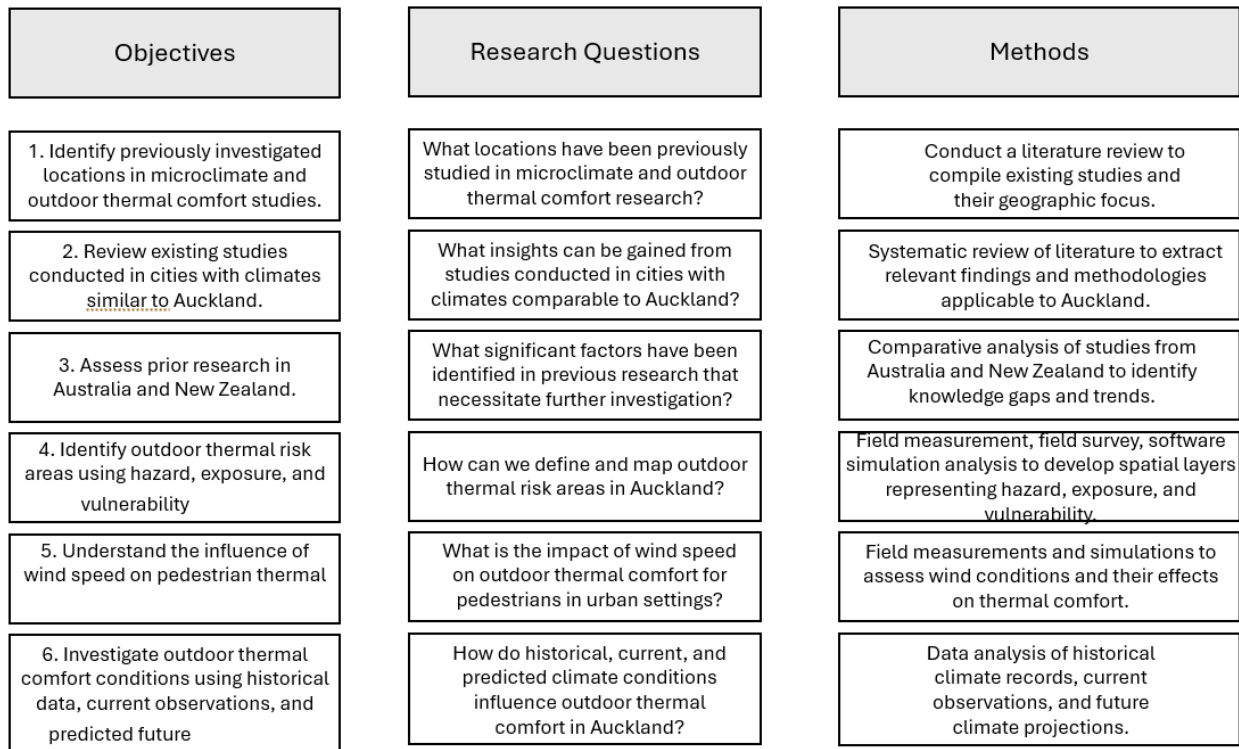

Figure 1.5 Research framework

1.11 Location of research

For selecting a location as a case study, it was decided to choose an area in the Central Business District (CBD) of Auckland. This area is the most populated and utilized part of Auckland, making it a priority for identifying thermal risk areas, and assessing the level of outdoor thermal comfort especially when considering the impacts of urban heat islands. Furthermore, the effects of urban planning, particularly the use of different materials and high-rise buildings with less greenery, on the microclimate are highlighted (Jalali et al., 2022). Auckland University of Technology was selected as a sample area in the CBD because this location comprises various urban design elements, including different geometries and materials, and also provides a conducive environment for conducting field surveys and gathering perceptions on outdoor thermal comfort from individuals of diverse ages and nationalities (Kumar & Sharma, 2020).

1.12 Thesis organization

This PhD thesis is organised into eight chapters as follows:

Chapter 1 introduces the research, providing definitions of microclimate and outdoor thermal comfort and highlighting the significance of these subjects for the study. This chapter defines thermal risk areas and explains how they can be identified through the design of different layers, namely the layer of hazard, layer of exposure, and layer of vulnerability for locations. It extensively describes the various approaches that can be utilized for assessing microclimate and outdoor thermal comfort. Geometry, materials, and vegetation are identified as the main parameters that impact microclimate and outdoor thermal comfort. The chapter then showcases research gaps, demonstrating the rationale and significance of the current study. It outlines the research aim based on six different objectives, each raising various questions addressed in six subsequent chapters. Following this, the chapter presents research contributions, methods, and thesis organization.

Chapter 2, addressing objective 1, presents a comprehensive review of location selection criteria and trends for microclimate and outdoor thermal comfort research. Despite the emphasis on selecting appropriate locations, the absence of readily available guidelines complicates a unified approach. The chapter thoroughly reviews 178 relevant articles published from 2015 to 2022, identifying common location typologies such as neighbourhoods, urban streets, universities, parks, squares, and courtyards. While previous studies cover a satisfactory range of locations, there are still areas for future exploration. The chapter categorizes criteria for location selection, including climate type, study period, location dimensions, density, intensity, and investigated factors impacting microclimate and thermal comfort. The findings highlight a focus on geometry and greenery in high-density temperate climates, which constitute the majority of studied locations. Over half of the documents were conducted in temperate regions, emphasizing the priority of investigating microclimatic conditions and

thermal comfort in these climates, known for fluctuating temperatures and significant rainfall (Böcker et al., 2013). The findings of this research are anticipated to be utilized as guidelines for selecting locations for microclimate and outdoor thermal comfort studies.

Chapter 3, corresponding to objective 2, delves into previous studies on microclimate and outdoor thermal comfort in cities with a Cfb climate based on the Köppen climate classification. Despite ample warnings from earlier researchers regarding the Urban Heat Island (UHI) effect and global climate change in Cfb cities worldwide (Ulpiani, 2021), these concerns have been overlooked in the realm of microclimatic studies and outdoor thermal comfort. The findings indicate that, out of more than 50 Cfb cities globally, the number of microclimatic publications meeting our criteria is fewer than 45, with representation from only 17 Cfb cities. On average, each Cfb city has fewer than 3 papers. Despite limited exploration, the selected papers underscore mean radiant temperature and air temperature as significant considerations in microclimatic studies of Cfb cities. Attention has been drawn to vegetation cover and material albedo, particularly acknowledging the role of trees in reducing air temperature through evaporation and shadowing. Suggestions include greening building facades to alleviate rising mean radiant temperatures and using low-albedo and lightweight materials to decrease mean radiant temperature, highlighting the need for further investigation in these crucial areas.

Chapter 4, aligned with objective 3, scrutinizes previous research on analysing microclimate and outdoor thermal conditions in Australia and New Zealand. Given the distinct climates, predicted climate change, population growth, and limited previous studies, a deeper understanding is essential. Examining major cities in both countries, this chapter analyses 42 papers meeting defined criteria—5 in Australia and 3 in New Zealand. Predominantly, these papers focus on people's thermal perceptions in residential areas during summer, with an emphasis on Melbourne and Sydney in Australia. However, a more comprehensive

understanding in Australia necessitates examining microclimate conditions in various cities, including often-neglected ones like Darwin with unique high humidity and heavy rains. In contrast, drawing conclusions about New Zealand faces challenges due to limited studies, neglect of urban morphology effects, and a lack of research in Central Business Districts (CBDs). Prior studies have not proposed solutions for mitigating wind speed, rainfall, and the impacts of urban contexts on microclimate conditions. In summary, past studies in Australia and New Zealand underscore the significant role of greenery in improving microclimatic conditions and outdoor thermal comfort, particularly during summer.

Chapter 5, aligned with objective 4, aims to identify outdoor thermal risk areas by utilizing a multi-layered approach involving hazard, exposure, and vulnerability on specific summer days in 2023. This process involves overlaying Physiologically Equivalent Temperature (PET) exceeding 23°C from the hazard layer, utilizing Envi-met simulation, identifying areas with the highest intensity from the exposure layer through on-site observations, and pinpointing discomfort areas based on meteorological conditions through field surveys. To comprehend future thermal comfort patterns, PET (hazard layer) in high-risk areas for the summers of 2050 and 2080 was analysed using future climate data generated by climate change world weather file generators (CCWorldWeatherGen) and representative concentration pathways (RCPs). This analysis reveals projected increased PET values in high thermal risk areas, particularly under the RCP8.5 scenario. As an intervention, replacing a concrete wall with a green wall and planting trees resulted in an average PET reduction, creating more comfortable outdoor thermal areas based on current conditions.

Chapter 6, aligning with objective 5, focuses on wind speed as a crucial factor influencing human comfort in diverse urban areas. Given Auckland's consistently high wind speeds throughout the year, the research aims to analyse the range of wind speeds for different time periods. The selected location is segmented into four distinct areas, further divided into 12

zones based on aspect ratios. Chapter findings reveal that over 55% of respondents reported experiencing windy conditions in both summer and winter. Survey results, correlated with the Beaufort Scale for wind intensity, categorize areas with wind speeds below 3.3 m/s as comfortable (perceptible and tolerable ranges) and those exceeding 3.4 m/s as high-risk areas (moderately/significantly unpleasant), based on ANSYS simulation maps for Auckland. The research identifies north-east winds during summer as the most challenging conditions, affecting seven zones, deemed moderately/significantly unpleasant. ANSYS simulations underscore that similar aspect ratios can lead to varied wind speed patterns during comparable time periods. This emphasizes the importance of considering location orientation, wind directions, building arrangements, and aspect ratio shapes in understanding the impact of urban designs on wind speeds, as recommended in previous studies (Ali-Toudert & Mayer, 2006, Abd Razak et al., 2013).

Chapter 7, aligning with objective 6, investigates the impacts of historical and future climate change projections on outdoor thermal comfort patterns. Utilizing historical climate data from 2000 to 2022 and predicted future climate patterns based on RCP 4.5 and RCP 8.5 for the near future (2040), mid-future (2090), and far future (2110), the research examines Auckland's climate. With the current urban design, the selected location experiences slight heat and cold stress during both summer and winter. Analysing future outdoor thermal comfort patterns indicates a moderate increase for both scenarios across the three selected time periods in both seasons. In the worst-case scenario, thermal perceptions may reach moderate heat stress in summer by 2110. Predicted future climate scenarios suggest that increasing air temperature will transition thermal perceptions from slight cold stress to comfortable and neutral conditions during winter. The study highlights that positive impacts of greenery are more significant than changing the aspect ratio. While increasing the aspect ratio could worsen PET levels,

decreasing it has no significant impact. Greenery positively influences PET levels, indicating a range of thermal perceptions within the comfort and neutral range in the selected location.

In Chapter 8, the research aim, objectives, research questions, significant findings, and recommendations for Auckland urban design are reviewed, followed by discussions. The chapter also presents the contribution to knowledge and discusses limitations and recommendations for future research.

To enhance the impact of the research findings on existing knowledge, the thesis adopts the approach of 'thesis by publications' or Pathway 2. This method, gaining global popularity, allows PhD candidates to integrate journal articles into their theses (Matas, 2012, Barry et al., 2018). This practice is increasingly recognized as a standard for securing positions in the competitive international job market for doctoral graduates (East et al., 2017, Mason, 2018). Furthermore, it serves to elevate the overall quality of universities' students, enabling them to solidify and broaden their standing in the academic market (Matas, 2012).

Moreover, adopting this method ensures the research's quality. It is observed that contemporary thesis examiners increasingly expect theses to represent publishable research (Matas, 2012). Additionally, the esteemed status of journal articles is undeniable, as they hold recognition in local, national, and international evaluation systems (Golding et al., 2014, Merga, 2015). Consequently, Pathway 2 is deemed the fitting approach for this research. In essence, the thesis chapters, encompassing research aims and objectives, are crafted as articles intended for submission to high-quality journals. This allows for expert feedback through the peer-review process, validating and confirming the results and contributions of each chapter in the thesis.

Chapter 2 Navigating the microclimates and outdoor thermal comfort studies: A comprehensive review of location selection criteria and trends

2.1 Prelude

This chapter aims to provide insight into criteria for selecting locations for analysing microclimate and outdoor thermal comfort. Due to predicted climate change and population growth worldwide, the initial step in enhancing city liveability involves identifying previous research locations. In this chapter, three main factors are considered for identifying these locations. The first factor is the type of climate based on the Köppen climate classification, aiming to determine which climates have received the most and least attention in studies. The second factor examines the types of locations considered in previous studies, while the last factor assesses the criteria and features that make these locations suitable for research. The popular locations for previous researchers and the neglected areas in this field will be demonstrated in this chapter. A peer review focused on 178 studies published between 2015 and 2022 in the field of microclimate and outdoor thermal comfort, utilizing both field measurements and software simulations. The results highlight several gaps that need to be addressed in future studies. Firstly, there is a predominant focus on single locations rather than comparing multiple areas, hindering a comprehensive understanding of the relationship between climate and design factors. Additionally, the majority of studies concentrate on hot periods, emphasizing the need for a broader analysis during cold periods to improve liveability and address anticipated climate change patterns. The selected areas typically fall within a limited size range, neglecting the potential detailed insights gained from smaller locations. Furthermore, the investigated parameters primarily emphasize geometry and vegetation, overlooking the significant role of materials in optimizing outdoor thermal conditions. The bias towards outdoor spaces neglects the importance of semi-outdoor areas, especially in challenging climates. The concentration on high-density and high-intensity areas leaves a gap

in understanding microclimatic conditions in medium and low-density settings, crucial for addressing population growth and climate change. Finally, the lack of studies on various climate types, particularly in neglected areas like Am (Tropical monsoon climate), emphasizes the need for future researchers to broaden their focus, considering predicted climate change, the urban heat island effect, and population growth in their analyses. Addressing these gaps is essential for developing more holistic and effective urban designs that prioritize outdoor thermal comfort in diverse climatic contexts. The findings of this research are anticipated to be utilized as guidelines for selecting locations for microclimate and outdoor thermal comfort studies.

2.2 Introduction

Over half of the world's population lives in cities (Matasov et al., 2020), urban planning must address local climate changes, mitigate urban heat islands (Abdi et al., 2020), and enhance outdoor thermal comfort (Elnabawi & Hamza, 2020). Unless the present rate of increase is managed (Wilkinson, 2016) global temperatures will rise by about 1.5°C between 2030 and 2050 (Elnabawi & Hamza, 2020). This will cause significant degradation to human wellbeing and ecosystem health. Mental and physical performance deteriorates at uncomfortably high temperatures; the urban environment experiences higher air temperatures than surrounding rural areas, known as the urban heat islands (UHIs) effects (Elnabawi & Hamza, 2020).

As a result of urbanization, the impact of the micro-thermal environment on thermal comfort levels has changed (Kim et al., 2020). Before identifying and mitigating the effects of micro-thermal climate change, planners must first comprehend the city's physical environment (Kim & Brown, 2022). Outdoor environments are diverse, with a variety of urban forms, surface materials, and landscapes (Elnabawi & Hamza, 2020). Direct sun radiation, reflection patterns, wind speed, and direction are all affected by these variables to contribute to a local microclimate (Elnabawi & Hamza, 2020). Providing shade to reduce direct sunlight exposure

improves the thermal comfort of urban residents since the ability to control air temperature in urban environments is limited (Taleghani et al., 2015). In short, each urban area is unique in terms of its population, cultural and socioeconomic development, as well as environmental challenges. Thus, the selection of location for urban climate studies is of critical importance to tailor the locality-dependent needs and to prioritize sustainable urban solutions.

In the past few decades, improving outdoor microclimatic and thermal comfort conditions has been a critical focus of research (Stathopoulos et al., 2004, Makaremi et al., 2012, Brown et al., 2015, Achour-Younsi & Kharrat, 2016, Huang et al., 2017, Gong et al., 2018, Abaas, 2020, Elnabawi & Hamza, 2020, Evola et al., 2020, Rossi et al., 2020, Xiong et al., 2020, Zhang et al., 2020, Cilek & Cilek, 2021, Kamal et al., 2021, Krebs & Johansson, 2021, Rosso et al., 2022). Both climatic and non-climatic factors influence the thermal comfort of outdoor environments (Morakinyo et al., 2019). Air Temperature (T_a), Relative Humidity (RH), Relative Wind Velocity (RVa), and The Mean Radiant Temperature (T_{mrt}) (Banerjee & Chattopadhyay, 2020) are the key climatic determinants of outdoor thermal comfort while personal aspects such as age, sex, and activity levels also have a significant impact on outdoor thermal preferences (Huang et al., 2018, Yang et al., 2020).

Specifically, there have been over 1600 scholarly works on the topic of "Thermal Comfort" and "Microclimate" since 1985, according to Dimensions. Similarly, Web of Science has recorded over 1300 works, while Scopus has documented more than 1700. These studies primarily concentrate on three key domains:

1. The impacts of morphology, vegetation, and building materials on microclimate
2. Thermal comfort and health risk evaluations
3. The productivity/competence of simulation tools in microclimatic studies and analysing outdoor thermal comfort

A critical factor in microclimate and outdoor thermal comfort studies is the selection of location since climate and environmental conditions differ from location to location (Yilmaz et al., 2022). Different areas of a city can experience different microclimates due to factors such as topography (Aksu & Küçük, 2020), vegetation (Weng et al., 2004), building density (Rezaei Rad et al., 2019), and surface materials (Forouzandeh, 2021). Outdoor thermal comfort (Ignatius et al., 2015), energy consumption (Pisello et al., 2016), and building performance (Hong et al., 2021) can all be affected by these microclimate differences. Additionally, different activities and occupations may require varying levels of thermal comfort (Havenith et al., 2002). Encouraging people to spend more time in outdoor spaces and enhancing liveability in outdoor areas has become a key factor in urban design (Shamsuddin et al., 2012). Therefore, the location factor must be considered when analysing microclimates and outdoor thermal comfort. An understanding of the unique environmental conditions (Nikolopoulou & Steemers, 2003) of a particular location can help designers and planners design outdoor spaces (Yang & Lin, 2016), buildings (Najafi & Shariff, 2011), and landscapes (Saelens et al., 2003) that are more energy efficient, provide more thermal comfort, and maximize overall user satisfaction (Chen & Ng, 2012). Although location selection in such trending scholarly works is one of the vital steps for evaluating microclimatic conditions, no previous attempt has comprehensively identified the characteristics of case study locations and the criteria behind it. As such, this research aims to provide a comprehensive overview of location selections and the criteria behind them for microclimatic studies, analysing outdoor thermal comfort. The objectives of this study are summarized as follows:

1. Identifying the most widely used locations in previous studies.
2. Categorizing locations into single or multiple ones based on the Köppen climate classification and analysing their achievements and recommendations for improving microclimate and outdoor thermal comfort conditions.
3. Recognizing the range of criteria considered for selecting them as case studies.

Hence, the outcomes of this study can be beneficial for future researchers seeking a deeper understanding of the criteria for selecting locations in microclimatic studies and analysing outdoor thermal comfort. The findings can also have implications for future research on microclimatic conditions in urban contexts by highlighting features of locations neglected in past research. Additionally, these findings may be of interest to architects and urban planners for analysing microclimatic conditions in various urban areas, aiming to reduce the impacts of urban contexts on climate change and the urban heat island effect.

2.3 Method

The selection of a database is of crucial in conducting scientific reviews due to its direct impact on the quality of findings (Kaynak, 2003). Dimensions is a cutting-edge and innovative, linked research data infrastructure and tool, re-imagining discovery and access to research: grants, publications, citations, clinical trials, patents, and policy documents. It provides access to over 106 million publications and has over 1.2 billion cited references across many disciplines (Hook et al., 2018). Due to its scientific integrity and completeness, the Dimensions has been selected as the main database for extracting publication items.

To begin, a search syntax was created to include phrases associated with the concept of "Microclimatic studies." In order to do this, the search string was created utilizing terms like "Microclimate," "Microclimatic conditions," and "Microclimatic studies." These keywords were then combined with "outdoor thermal comfort" using Boolean operators ("AND") to

create the search query that was used to access the Dimensions database and acquire the essential data.

The initial search was carried out using the titles, abstracts, and keywords of publication materials within the Dimensions. This search returned 17308 documents from 1985 to 2022 including 12349 articles, 442 monographs, and 390 proceedings, 178 preprints, 3076 book chapters, and 873 edited books. To eliminate out papers unrelated to the goals of this study, various filters were applied. First, only articles were included in the search because of their thoroughness and reputation as “certified knowledge” (Olawumi & Chan, 2018). Second, publications written in non-English languages were excluded. Third, resources unrelated to the building and environment (e.g., resources belonging to medical, and forestry sciences) were excluded. As a result, 793 documents were found that met the initial criteria. Next, to primarily emphasize published papers with the highest potential level of result accuracy – papers that focused on the integration of “software simulation” and “field measurement” – following a deductive approach, 420 articles out of the total poll of 793 were shortlisted. Eventually, since over 50% of all the shortlisted articles were published from 2015 onwards and software simulations as well as field measurement methods have become more advanced (Ma et al., 2019) in these years, 146 of the most relevant articles covering the 2015-2022 period were selected and thoroughly reviewed. To ensure that no research-worthy content was missed, similar keywords were searched on additional scholarly platforms like Scopus, Web of Science, and Google Scholar (in case it would not be indexed by Dimensions). If there were no duplicates, the detected resources were compared to the preliminary database and taken into consideration for inclusion. As a result, the preliminary database was expanded by 32 more articles, bringing the total number of identified items to 178 (Figure 2.1).

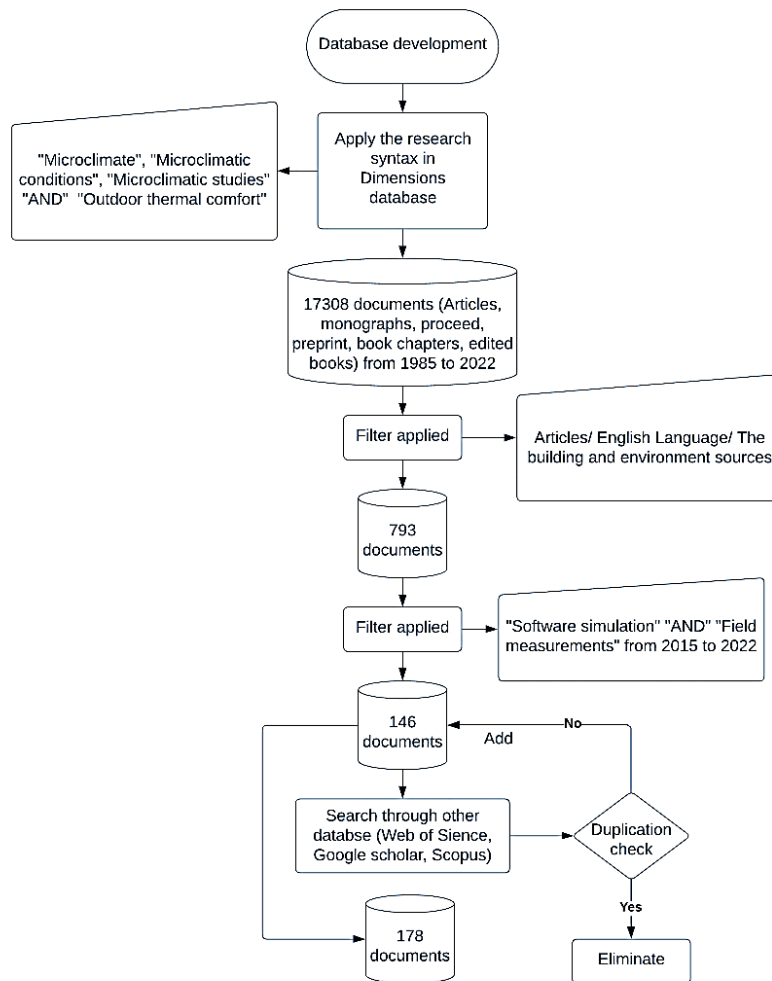

Figure 2.1 Paper Selection Criteria

After analysing the 178 selected papers for this review, we found that previous researchers focused on studying specific locations, namely neighbourhoods, urban streets, university campuses, public squares, urban parks, and public courtyards (Figure 2.2). While other locations, such as governmental buildings (Fabbri et al., 2020), were considered, they were excluded from this research due to their infrequent occurrence. Therefore, after excluding infrequent locations, we analysed the criteria of 173 selected papers in detail.

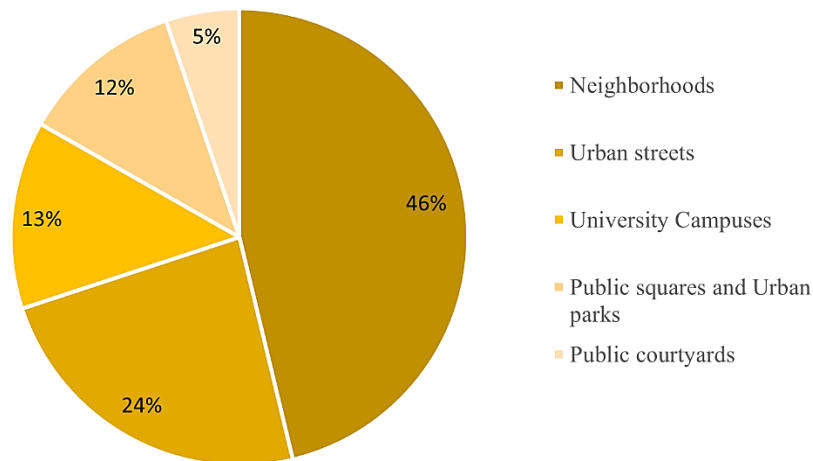

Figure 2.2 The main locations studied by previous researchers, based on selected papers

As stated earlier, this research categorized studies into a) single-case and b) multiple-case research works.

- a) For single-case research works, factors of “climate based on Köppen classification”, “the study period”, “dimensions”, “investigated parameters”, “intensity”, and “density” were analysed.
- b) For multiple-case research works, in addition to the above parameters, “quantity of investigated areas”, “similarities” and “differences”, were also assessed.

In the following analysing, spaces that are partially open towards the outdoors are referred to as semi-outdoor areas; hot seasons are defined as summer and spring, while cold seasons are defined as fall and winter. Density is the number of people or elements of an urban form (like dwelling units or floor area) per unit area of land, whereas intensity is the concentration of commercial and service activities on the ground floors along city streets (Sevtsuk et al., 2013).

Moreover, within each location category, we also investigated the climate of the respective locations. This exploration aimed to understand the frequency of previous studies in different climates and to analyse the achievements and recommendations for improving microclimate

and outdoor thermal comfort conditions under various climatic conditions. For climate classification, we used the Köppen climate categories.

Köppen climate categorization is one of the most widely used climate systems (Chen & Chen, 2013). According to the Köppen climate classification, climates are divided into five primary groups based on seasonal precipitation and temperature trends, A (tropical), B (dry), C (temperate), D (continental), and E (polar) are the five primary types (Chen & Chen, 2013, Beck et al., 2018). The main climatic groups are determined by the types of vegetation that thrive in each climate classification region. While the second letter denotes the type of seasonal precipitation, the third letter indicates the degree of heat (Belda et al., 2014, Beck et al., 2018). In the following, we classified the relevant papers of each category based on Köppen climate classification (Table 2.1).

Table 2.1 Climate types according to Köppen (Beck et al., 2018)

Group	Second letter code	Third letter code
A-Tropical	f (Rainforest)	
	m(Monsoon)	
	w(Savanna, Dry winter)	
	s(Savanna, Dry summer)	
B-Dry	w(Desert)	h(Hot)
	s(Steppe)	k(Cold)
C-Temperate	w(Dry winter)	a (Hot summer)
	f(No dry season)	b (Warm summer)
	s(Dry summer)	c (Cold summer)
D-Continental	w (Dry winter)	a (Hot summer)
	f (No dry season)	b (Warm summer)
	s (Dry summer)	c (Cold summer)
		d (Very cold winter)
E-Polar	T (Tundra)	
	F (Eternal frost (ice cap))	

2.4 Results

After classifying the selected papers into various categories based on the types of locations and their climate classifications, we initially endeavoured to comprehend their accomplishments and recommendations for enhancing microclimate and outdoor thermal comfort in the chosen locations. Subsequently, we organized these findings into the following tables. Additionally, we sought to identify the primary criteria that previous researchers considered when selecting their locations.

2.4.1 Neighbourhoods

Daily life, health, education, work, and other variables are all influenced by a neighbourhood (Israel et al., 1994) As a result, most of our selected papers have chosen various neighbourhoods as the locations of microclimatic studies, with 49 papers for single neighbourhoods and 31 total papers for multiple ones out of 80 papers. In Table 2.2, we classified all selected papers in this category. Based on selected papers, most of the chosen neighbourhoods have high population density, which can result in increased heat buildup and thermal discomfort. Selecting neighbourhoods as a case study provides researchers with an opportunity to analyse microclimate and outdoor thermal comfort on a relatively large scale, encompassing a variety of factors such as different building heights, orientations, and materials, as well as green spaces. Moreover, in neighbourhoods, researchers can conduct field surveys with a wide range of people with varying thermal acceptance ranges.

Table 2.2 The list of selected papers of neighbourhoods based on Köppen climate classification and their achievements

Authors (2015-2022) – Focusing on software simulation & field measurements	
Different climate classifications	Achievements
A (tropical) Af: (Jamei et al., 2017, Roth & Lim, 2017, Nazarian et	<ul style="list-style-type: none"> • High-albedo pavement materials and water bodies are not effective in reducing heat stress in hot and humid climate conditions. • Shade trees over grass are the most effective landscape strategy for cooling the microclimate in hot and humid climates.

<p>al., 2018, Yang et al., 2018, Wai, et al., 2020, Acero et al., 2021)</p> <p>Aw:(Sharmin et al., 2015, Sharmin et al., 2017, Yahia et al., 2018, Chatterjee et al., 2019, Mehrotra et al., 2019, Banerjee et al., 2020, Srivanit & Jareemit, 2020, Rajan & Amirtham, 2021, Banerjee et al., 2022)</p>	<ul style="list-style-type: none"> • Providing adequate urban parameters for high-rise developments can improve outdoor thermal comfort in hot and humid tropical regions. • Strategies to enhance urban ventilation are favored in higher densities, while strategies to minimize radiation are needed for lower urban packing densities. • Dense trees help to reduce heat stress, but vegetation may negatively affect wind ventilation. • Uniform heights, equal building separation, and plot sizes can lead to harsher urban microclimates. • Pedestrians in formal planned areas or less diverse traditional areas are less comfortable than those in more variable areas. • The aspect ratio and street canyon orientation can significantly improve outdoor thermal comfort performance compared to increases in building density or decreases in tree-planting distance. • Vegetation plays the most significant role in determining the surface energy balance in the study area compared to cool roofs and cool pavements.
<p>B (Dry)</p> <p>Bwh: (Song & Wang, 2015, Jihad & Tahiri, 2016, Ragheb et al., 2016, Barakat et al., 2017, Shaeri et al., 2018, Zhao et al., 2018, Abaas, 2020, Aghamolaei et al., 2020, Crank et al., 2020, Galal et al., 2020, Habibi et al., 2020, Bande et al., 2021)</p> <p>Bwk: (Sosa et al., 2017)</p>	<ul style="list-style-type: none"> • Designing the optimal tree arrangement is important to maximize overall thermal benefits for residential neighborhoods, especially in hot arid desert environments. • In a desert city like Phoenix, xeric trees may be preferred to mesic urban lawns for daytime cooling. • Lawns can reduce urban temperatures through evaporative cooling but require large amounts of water for continuous irrigation. • High-rise structures can offer tolerable solutions by providing ample shade through casting shadows. • The Urban Heat Island (UHI) effect can be reduced by using high-albedo construction materials. • Aspect ratio and orientation are the most impactful factors at the neighborhood scale for improving outdoor thermal comfort. • At the neighborhood level, increasing the average residential density provides a higher rate of thermal comfort in hot and arid climates. Also, the higher overall open space area to total area broadens the spectrum of observed areas with severe heat stress. • Buildings with deep streets can still maintain acceptable pedestrian comfort over the year in urban design. • Creating thermally efficient cities in arid zones requires using the best combination of urban grids forms and urban canyons design.
<p>C (Temperate)</p> <p>Cfa: (Li et al., 2016, Liu et al., 2016, Ali & Li 2018, Lobaccaro et al., 2018, Zhang et al., 2018, Ma et al., 2019, Wang et al., 2019, Lemonsu et al., 2020, Ouyang et al., 2021, Kim & Brown, 2022)</p> <p>Cfb:(Gros et al., 2016, Lee & Mayer, 2016,</p>	<ul style="list-style-type: none"> • The impact of vegetation on both heat environment and ventilation depends on tree arrangement, crown width, and tree height. • Evergreen species with an Aspect Ratio of Trees < 2 can decrease wind speed in winter and block direct sunlight, resulting in negative effects on PET. • Tall trees with a large Leaf Area Index and canopy diameter should be a priority to improve the comfort of outdoor environments. • A surface cover of 30–40% greenspace within the built-environment can maximize summer cooling without much compromise in the winter. • The combined use of cool materials and additional tree planting can contribute to lower air temperatures through shading and leaves' evapotranspiration. • Designing awning textiles with highly-reflective, highly-emissive properties upward and highly-reflective but low-emissive properties downward can be beneficial. • Cool pavements can cause significant reductions in surface air temperatures and small changes in mean radiant temperature during the day.

Martins et al.,
2016, Lee &
Mayer, 2018,
Deng et al., 2019,
Hertel & Schlink,
2019, Jamei et al.,
2019, Othmer et
al., 2020, Lehnert
et al., 2021,
Rahman et al.,
2022)

- The increase in height of taller high-rise buildings can cause a corresponding increase in wind speed in neighborhood districts.
- Trees have a significant influence in reducing heat stress in urban centers during summer days.
- Lawns cannot provide any substantial reduction of thermal exposure compared to paved surfaces.
- The combination of cool materials (e.g., white reflective plaster) and an increase in the buildings' height could reduce thermal discomfort.
- A larger sky view factor (SVF) is preferred for cooling open spaces in hot and humid regions if direct sunlight is already blocked by urban morphology.

Csa:(Battista et al.,
2016, Taleghani et
al., 2016, Tsitoura
et al., 2016,
Tumini et al.,
2016,
Makropoulou,
2017, Tsoka et al.,
2017,
Chatzinikolaou et
al., 2018, Lau et
al., 2018, Laureti
et al., 2018,
Mohsen et al.,
2020, Rossi et al.,
2020, Aghamolaei
et al., 2021,
Hadavi &
Pasdarshahri,
2021, Chen et al.,
2022)

Cwa: (Tan et al.,
2016, Lai et al.,
2017, Wang et al.,
2018, Lau et al.,
2019, Morakinyo
et al., 2019, Tan et
al., 2019)

<p>D (Continental)</p> <p>Dwa:(Wu et al., 2016, Taleghani & Berardi, 2018, Han et al., 2019, Berardi et al., 2020, Gatto et al., 2020, HosseiniHaghighi et al., 2020, Leng et al., 2020, Mi et al., 2020, Brozovsky et al., 2021, Dardir & Berardi, 2021, Su et al., 2022, Yin et al., 2022)</p> <p>Dfb: (De Luca et al., 2021)</p>	<ul style="list-style-type: none"> • The outdoor thermal environment in Dalian can be improved by adjusting the orientation of buildings, increasing the sunshine spacing coefficient, dislocating buildings, or adopting a peripheral-type building layout. • Vegetation can significantly reduce near-surface air temperature, especially the combination of grass and mature trees. • While grass can help improve outdoor thermal comfort, trees are more effective in reducing the duration and expansion of suffering from severe heat stress. • Greater building height or length has a greater hindering force to air (heat) flow. • Optimum design strategies for open spaces were proposed within the implementation of shelterbelts, shaded facilities, and deciduous trees. • Trees and green cover have the important potential to offset climate change impact and to make urban environments less thermally stressful and wind sheltering resulted in an increase in outdoor thermal comfort.
---	--

Results of analysis single neighbourhoods

While most of these studies have been conducted in high-density neighbourhoods (Song & Wang, 2015, Gros et al., 2016, Li et al., 2016, Liu et al., 2016, Tan et al., 2016, Tumini et al., 2016, Barakat et al., 2017, Tsoka et al., 2017, Ali & Li, 2018, Lee & Mayer, 2018, Taleghani & Berardi, 2018, Yahia et al., 2018, Zhang et al., 2018, Zhao et al., 2018, Hertel & Schlink, 2019, Ma et al., 2019, Mehrotra et al., 2019, Morakinyo et al., 2019, Abaas, 2020, Banerjee et al., 2020, Crank et al., 2020, Lemonsu et al., 2020, Rossi et al., 2020, Wai et al., 2020, Acero et al., 2021, Dardir & Berardi, 2021, Hadavi & Pasdarsahri, 2021, Rajan & Amirtham, 2021, Kim & Brown, 2022) and temperate areas, low-density areas were not the main focus point (Ragheb et al., 2016, Roth & Lim, 2017, Shaeri et al., 2018, Jamei et al., 2019, Banerjee et al., 2020, Ouyang et al., 2021). Also, several studies have been done on high-intensity mixed-use neighbourhoods (Song & Wang, 2015, Battista et al., 2016, Gros et al., 2016, Lee & Mayer,

2016, Taleghani et al., 2016, Tan et al., 2016, Barakat et al., 2017, Ali & Li, 2018, Shaeri et al., 2018, Yang et al., 2018, Ma et al., 2019, Mehrotra et al., 2019, Abaas, 2020, Lemonsu et al., 2020, Mohsen et al., 2020, Wai et al., 2020, Acero et al., 2021, Rajan & Amirtham, 2021, Kim & Brown, 2022, Rahman et al., 2022), followed by residential instances (Li et al., 2016, Liu et al., 2016, Tsoka et al., 2017, Nazarian et al., 2018, Yahia et al., 2018, Zhang et al., 2018, Zhao et al., 2018, Hertel & Schlink, 2019, Dardir & Berardi, 2021, Hadavi & Pasdarshahri, 2021). A majority of the reviewed studies looked at outdoor thermal comfort during a hot period (Battista et al., 2016, Gros et al., 2016, Barakat et al., 2017, Roth & Lim, 2017, Ali & Li, 2018, Lee & Mayer, 2018, Yahia et al., 2018, Yang et al., 2018, Zhao et al., 2018, Abaas, 2020, Banerjee et al., 2020, Lemonsu et al., 2020, Mohsen et al., 2020, Wai et al., 2020, Acero et al., 2021, Rajan & Amirtham, 2021, Kim & Brown, 2022), and the average area of investigations from all review studies was more than 250000 m² (Li et al., 2016, Ragheb et al., 2016, Tumini et al., 2016, Chatzinikolaou et al., 2018, Nazarian et al., 2018, Taleghani & Berardi, 2018, Zhang et al., 2018, Zhao et al., 2018, Mehrotra et al., 2019, Crank et al., 2020, Acero et al., 2021, Rajan & Amirtham, 2021, Su et al., 2022). While urban geometry and vegetation have been the major points of emphasis in determining outdoor thermal comfort in neighbourhoods (Song & Wang, 2015, Battista et al., 2016, Li, et al., 2016, Liu et al., 2016, Barakat et al., 2017, Roth & Lim, 2017, Lee & Mayer, 2018, Nazarian et al., 2018, Yahia et al., 2018, Zhang et al., 2018, Zhao et al., 2018, Deng et al., 2019, Mehrotra et al., 2019, Morakinyo et al., 2019, Abaas, 2020, Crank et al., 2020, Acero et al., 2021, Dardir & Berardi, 2021, Ouyang et al., 2021, Rajan & Amirtham, 2021, Kim & Brown, 2022, Rahman et al., 2022, Su et al., 2022), few studies have investigated the effects of materials (Lee & Mayer, 2016, Ragheb et al., 2016, Chatzinikolaou et al., 2018, Shaeri et al., 2018, Taleghani & Berardi, 2018, Yang et al., 2018, Ma et al., 2019) and have analysed semi-outdoor areas (Song & Wang, 2015, Barakat et al., 2017, Yahia et al., 2018, Othmer et al., 2020, Wai et al., 2020).

Location selection criteria analysis for single locations, focused on analysing microclimatic conditions in one neighbourhood, are visually summarized in Figure 2.3.

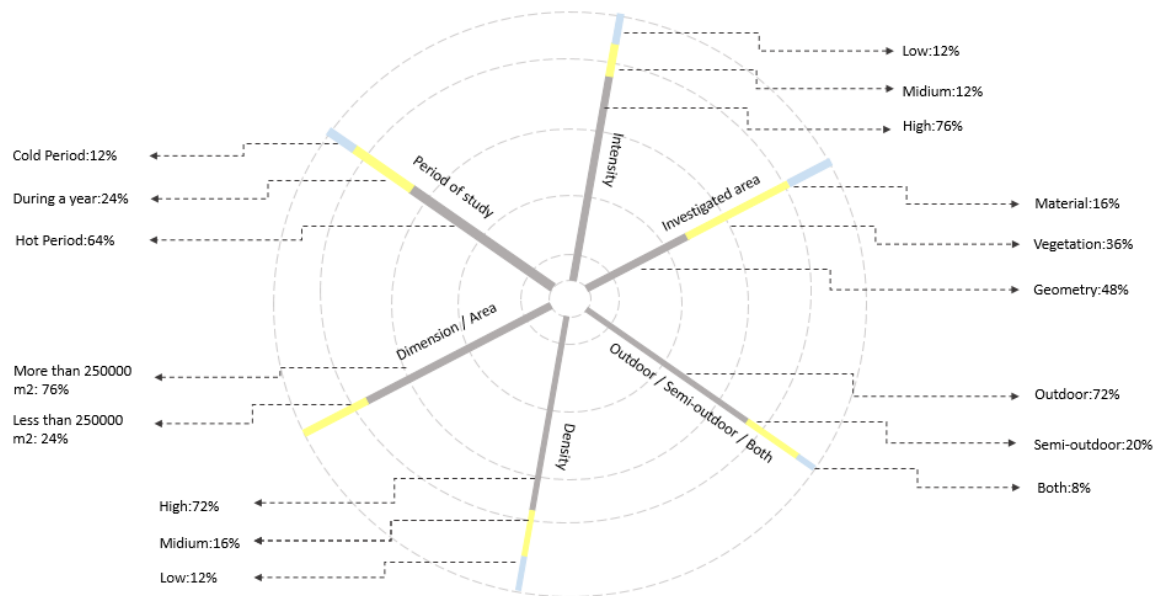

Figure 2.3 Location selection criteria analysis - single neighborhoods

Results of analysis multiple neighbourhoods

The most common comparison was identified as the review of traditional neighbourhoods against modern neighbourhoods (Tsitoura et al., 2016, Lau et al., 2018, Galal et al., 2020, Habibi et al., 2020, Bande et al., 2021, Lehnert et al., 2021, Banerjee et al., 2022), followed by comparing varied usage of mainly residential and commercial areas (Jihad & Tahiri, 2016, Jamei et al., 2017, Lau et al., 2018, Srivanit & Jareemit, 2020, De Luca et al., 2021), and a majority of these investigations included at least 3 neighbourhoods (Sharmin et al., 2015, Sosa et al., 2017, Lau et al., 2018, Wang et al., 2018, Chatterjee et al., 2019, Galal et al., 2020, Leng et al., 2020) which were evaluated during hot periods in temperate climates (Lai et al., 2017, Lau et al., 2018, Lobaccaro et al., 2018, Wang et al., 2019). The greater portion of studies compared neighbourhoods based on varying densities, architectural designs, significantly different building heights, orientations, aspect ratios, materials, and vegetation coverage

(Sharmin et al., 2015, Jihad & Tahiri, 2016, Jamei et al., 2017, Lai et al., 2017, Sharmin et al., 2017, Sosa et al., 2017, Wang et al., 2018, Berardi et al., 2020, Habibi et al., 2020, Srivanit & Jareemit, 2020, Bande et al., 2021, Lehnert et al., 2021).

Location selection criteria analysis for multiple locations are visually summarized in Figure 2.4.

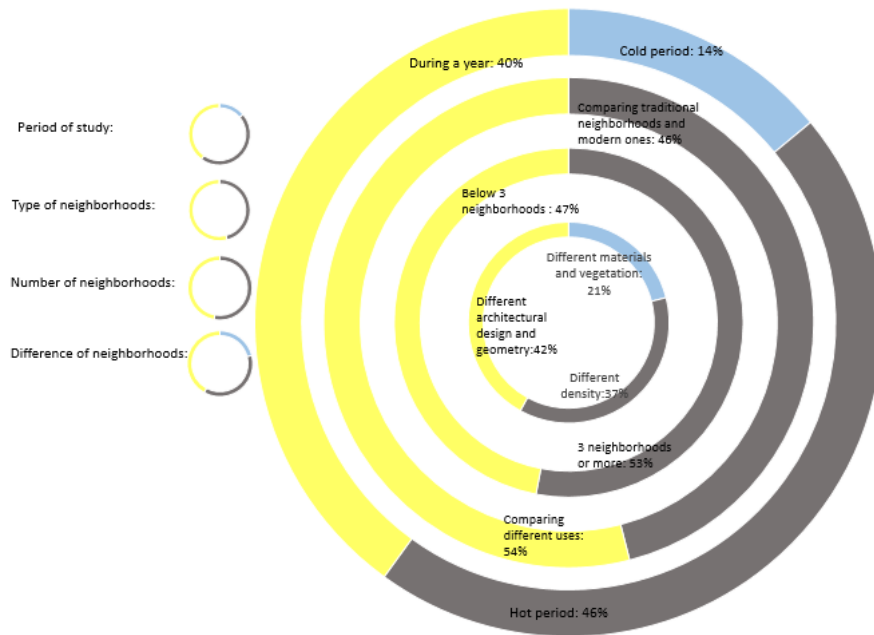

Figure 2.4 Location selection criteria analysis – multiple neighborhoods

2.4.2 Urban Street

Urban streets have been a prominent area for microclimate research (Ng et al., 2012). According to our criteria, 20 papers have focused on single urban streets and 21 total papers for multiple ones out of 41 papers. In Table 2.3, we classified all selected papers in this category. Based on selected papers, researchers often select high-rise and high-density urban streets, where the street is enclosed by walls of buildings. This can affect the distribution of solar radiation, wind patterns, and air temperature, which can significantly impact outdoor thermal comfort. The design of the street, including the pavement width, presence of trees and greenery, and placement of buildings and other structures, can all affect the microclimate and

outdoor thermal comfort. Additionally, researchers can conduct field surveys in urban streets with a wide range of people with various thermal acceptance ranges.

Table 2.3 The list of selected papers of urban streets based on Köppen climate classification and their achievements

Authors (2015-2022) – Focusing on software simulation & field measurements	
Different climate classifications	Achievements
<p>A (tropical)</p> <p>Af:(Yang et al., 2016, Meili et al., 2021)</p> <p>Aw:(De & Mukherjee, 2018, Rodríguez-Algeciras et al., 2018, Deevi & Chundeli, 2020)</p>	<ul style="list-style-type: none"> • NW-SE oriented street is more stressful than the NE-SW street in the afternoon in terms of thermal comfort. • An increase in tree and ground vegetation fractions provides a better outdoor thermal comfort compared to a change in vegetation. • E-W street canyons are the most thermally stressed ones.
<p>B (Dry)</p> <p>Bwh:(Venhari, Tenpierik et al., 2019, Elnabawi & Hamza, 2020, Hegazy & Qurnfulah, 2020, Nasrollahi et al., 2021)</p>	<ul style="list-style-type: none"> • People who live in hot arid climates have a wider range of adaptation and tolerance to local climatic conditions. • Increased average building height can effectively impede solar radiation during the daytime. • The effect of the Sky view factor on the West-East streets are more significant than in South-North streets. • By reducing the canyon aspect ratio, outdoor thermal comfort increases as well.
<p>C (Temperate)</p> <p>Cfa:(Chatzidimitriou & Yannas, 2017, Milošević et al., 2017, Zhang et al., 2017, Gong et al., 2019, Zhang et al., 2019, Deng & Wong, 2020, Muniz-Gaal et al., 2020, Abdollahzadeh & Biloría, 2021, Bartsaghi-Koc et al., 2021, Chen et al., 2021)</p> <p>Cfb:(Klemm et al., 2015, Martins et al., 2016, Sanusi et al., 2016, Lee & Mayer, 2018, Jamei & Rajagopalan, 2019)</p> <p>Csa:(Achour-Younsi & Kharrat, 2016, Evola et al., 2019, Lee et al., 2019, Evola et al., 2020,</p>	<ul style="list-style-type: none"> • There is an obvious correlation between the trees and the reduction of PET values. • Reduced percentage of hardened ground with lower albedo designers can use paving materials with higher albedo to improve the outdoor thermal environment. • Shallow canyons are susceptible to worse thermal condition when compared to their deeper counterparts with similar aspect ratio value. • The increase of the albedo worsens daytime thermal comfort for pedestrians, while shading by trees, which are planted in the right location, leads to a reduction of outdoor human heat stress at least on the sidewalks of street canyons. • Street orientation has a significant impact on the solar radiation received in a high-density street canyon. • Street canyons with West-East orientation receive higher solar irradiation during summer and lower during winter compared to those with South-North orientation. • A comfortable microclimate can be provided by roadside trees in heavily built-up urban environments in subtropical cities. • Canyons with a higher (height/width) aspect ratio increase the wind speed and shading by buildings, thereby improving the thermal comfort at the pedestrian level, especially in the summer. • The street canyons oriented southeast-northwest or with a higher aspect ratio provide more shade, higher wind speed, and better thermal comfort conditions for pedestrians.

<p>Natanian et al., 2020, Vasilikou & Nikolopoulou, 2020, El Bat et al., 2021) Csb:(Kim & Macdonald, 2017) Cwa:(Morakinyo et al., 2017, Tan et al., 2017, Gong et al., 2018, Morakinyo et al., 2018, Morakinyo et al., 2020, Ouyang et al., 2020)</p>	<ul style="list-style-type: none"> • In streets with high-percentage canopy cover, air temperature, relative humidity, solar radiation, and mean radiant temperature were significantly lower than in streets with low-percentage canopy cover.
<p>D (Continental) Dfb:(Yilmaz et al., 2021) Dwa:(Li et al., 2018, Ma et al., 2020)</p>	<ul style="list-style-type: none"> • The semi-open canopy design provided roads with high thermal comfort such that people can walk and cycle in wintertime. • Increasing average building height and building coverage ratio in canyon space can largely improve people’s thermal sensation. • There is a strong correlation between the reduction of PET and increases in the tree coverage ratio.

Results of analysis single urban streets

A large majority of the studies have been carried out in high-density, high-intensity urban streets (Martins et al., 2016, Kim & Macdonald, 2017, De & Mukherjee, 2018, Lee & Mayer, 2018, Li et al., 2018, Jamei & Rajagopalan, 2019, Lee et al., 2019, Zhang et al., 2019, Deevi & Chundeli, 2020, Deng & Wong, 2020, Ma et al., 2020, Morakinyo et al., 2020) and temperate climates, whereas others have been conducted out in medium-density, medium-intensity areas (Klemm et al., 2015, Yang et al., 2016, Morakinyo et al., 2017, Elnabawi & Hamza, 2020, Hegazy & Qurnfulah, 2020, Bartesaghi-Koc et al., 2021, El Bat et al., 2021, Yilmaz et al., 2021). Although most research has looked at outdoor thermal comfort during a hot period in most locations (Yang et al., 2016, Kim & Macdonald, 2017, De & Mukherjee, 2018, Lee et al., 2019, Zhang et al., 2019, Deevi & Chundeli, 2020, Deng & Wong, 2020, Hegazy & Qurnfulah, 2020, Ma et al., 2020, Bartesaghi-Koc et al., 2021), studying outdoor thermal comfort during the winter is also frequent in urban streets (Martins et al., 2016, Lee & Mayer, 2018, Jamei & Rajagopalan, 2019, Elnabawi & Hamza, 2020, El Bat et al., 2021, Yilmaz et al., 2021). Moreover, the average investigation street from all review studies was more than 20 meters

long (Klemm et al., 2015, Martins et al., 2016, Yang et al., 2016, Jamei & Rajagopalan, 2019, Zhang et al., 2019, Deevi & Chundeli, 2020, Morakinyo et al., 2020), and in studying outdoor thermal comfort in urban streets, urban geometry, particularly aspect ratio, is crucial (Yang et al., 2016, De & Mukherjee, 2018, Li et al., 2018, Lee et al., 2019, Zhang et al., 2019, Deevi & Chundeli, 2020, Deng & Wong, 2020, Elnabawi & Hamza, 2020, Ma et al., 2020, Bartesaghi-Koc et al., 2021, Yilmaz et al., 2021), followed by the impacts of materials (Morakinyo et al., 2017, Lee & Mayer, 2018, Li et al., 2018, Zhang et al., 2019, Hegazy & Qurnfulah, 2020, El Bat et al., 2021, Yilmaz et al., 2021). However, there have been fewer investigations on the effects of vegetation (Klemm et al., 2015, Martins et al., 2016, Kim & Macdonald, 2017, Morakinyo et al., 2017, Elnabawi & Hamza, 2020, Morakinyoe et al., 2020).

Location selection criteria analysis for single urban streets are visually summarized in Figure 2.5.

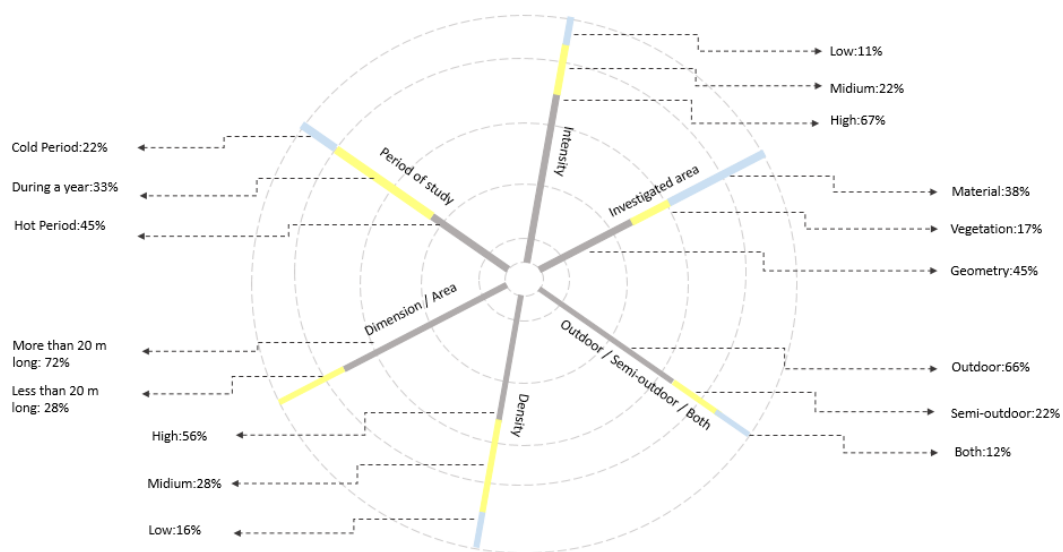

Figure 2.5 Location selection criteria analysis - single urban streets

Results of analysis multiple urban streets

Different pedestrian streets (Chatzidimitriou & Yannas, 2017, Zhang et al., 2017, Gong et al., 2018, Rodríguez-Algeciras et al., 2018, Evola et al., 2019, Venhari et al., 2019, Muniz-Gaal et

al., 2020, Vasilikou & Nikolopoulou, 2020, Abdollahzadeh & Bioria, 2021, Nasrollahi et al., 2021), especially those in commercial areas, are frequently compared, and over four streets (Chatzidimitriou & Yannas, 2017, Evola et al., 2019, Muniz-Gaal et al., 2020, Natanian et al., 2020, Ouyang et al., 2020, Chen et al., 2021, Nasrollahi et al., 2021) were picked and evaluated over a year (Achour-Younsi & Kharrat, 2016, Sanusi et al., 2016, Chatzidimitriou & Yannas, 2017, Milošević et al., 2017, Zhang et al., 2017, Morakinyo et al., 2018, Venhari et al., 2019, Natanian et al., 2020, Meili et al., 2021) in temperate climates during the majority of the investigation. Additionally, different streets have been examined based on differing densities, geometry, especially different building heights, street-wide, orientations, aspect ratios, and other materials (Achour-Younsi & Kharrat, 2016, Sanusi et al., 2016, Chatzidimitriou & Yannas, 2017, Milošević et al., 2017, Zhang et al., 2017, Gong et al., 2018, Rodríguez-Algeciras et al., 2018, Gong et al., 2019, Venhari et al., 2019, Muniz-Gaal et al., 2020, Vasilikou & Nikolopoulou, 2020, Abdollahzadeh & Bioria, 2021, Nasrollahi et al., 2021). Various vegetation coverages have been studied in less research (Tan et al., 2017, Gong et al., 2018, Morakinyo et al., 2018, Venhari et al., 2019, Evola et al., 2020, Ouyang et al., 2020, Chen et al., 2021, Meili et al. 2021).

Location selection criteria analysis for multiple urban streets are visually summarized in Figure 2.6.

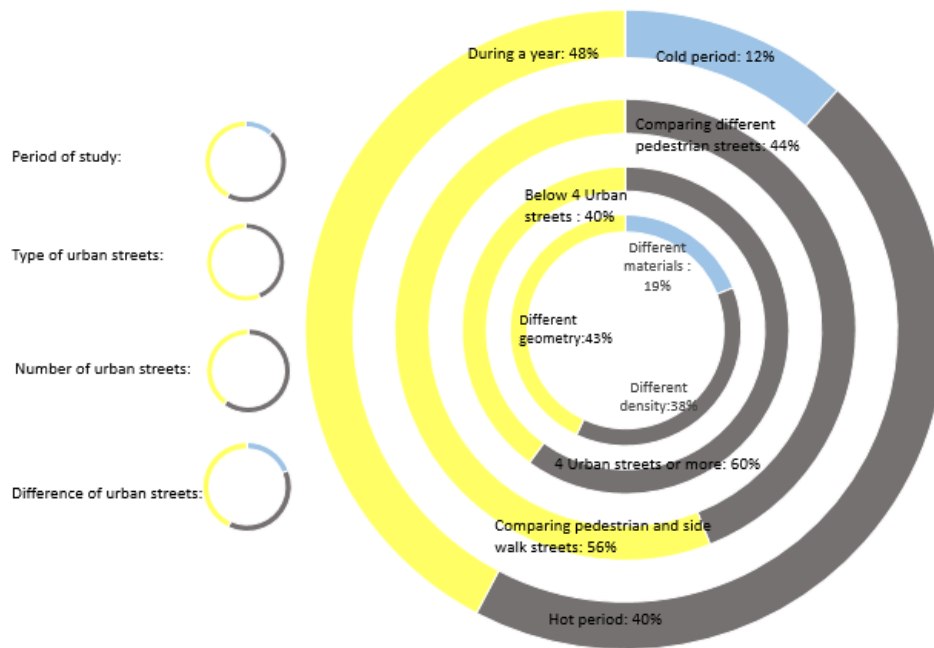

Figure 2.6 Location selection criteria analysis - multiple urban streets

2.4.3 University Campuses

Outdoor areas in universities are major gathering spots for students (Lau et al., 2014). Based on our criteria for literature review, we consider all papers of this section to be a single location because we have just found 23 studies focused on comparing different areas of a university. In Table 2.4, we classified all selected papers in this category. According to selected papers, universities are often chosen by researchers as a testbed for microclimate and thermal comfort research. This is because universities typically have large outdoor areas with different material covers and various building geometries. Furthermore, universities have an active environment and diverse population, which can have varying perceptions of thermal comfort. Additionally, universities often have existing infrastructure, such as weather stations and temperature sensors, which can be utilized for data collection and analysis.

Table 2.4 The list of selected papers of university campuses based on Köppen climate classification and their achievements

Different climate classifications	Achievements
<p>A (tropical)</p> <p>Af:(Aydin et al., 2019, Ghaffarianhoseini et al., 2019)</p>	<ul style="list-style-type: none"> • The significant impacts of shading and vegetation, can result in achieving outdoor spaces with high frequency of use and improved comfort level.
<p>B (Dry)</p> <p>Bwh:(Abdi et al., 2020, Fawzy Abdulsalam & Haleem Hussien, 2021, Shata et al., 2021)</p>	<ul style="list-style-type: none"> • The rectangular planting of evergreen trees in the outer rows and deciduous trees in the inner rows in a direction perpendicular to the prevailing wind produced the most optimal condition in improving outdoor thermal comfort. • Aspect ratio could be considered starting point to respect outdoor thermal comfort. • In summer, the results showed a significant direct impact of the sky view factor on mean radiant temperature (T_{mrt}), outdoor thermal comfort; however, in the winter, sky view factor did not affect the microclimatic variables.
<p>C (Temperate)</p> <p>Cfa:(Shooshtarian & Rajagopalan, 2018, Fang et al., 2019, Chen & Wu, 2020, Zhang et al., 2020, Fang et al., 2021)</p> <p>Cfb:(Taleghani 2018)</p> <p>Csa:(Salata et al., 2015, Salata et al., 2016, Salata et al., 2017, Battisti et al., 2018, Altunkasa & Uslu, 2020)</p> <p>Cwa: (Du et al., 2017, Huang et al., 2017, Du & Mak, 2018, Lee et al., 2020, Zhen et al., 2021)</p>	<ul style="list-style-type: none"> • Lift-up design can effectively improve pedestrian level wind environment and thermal comfort. • The role of cool materials in the mitigation of urban heat island effects. • The increase of albedo radiated more sun to the ground surface. • The position and orientation of high albedo materials can significantly affect pedestrians' thermal comfort in urban open spaces. • The importance of treed open spaces and the combination of permeable green pavements associated with cool roofs as the most effective strategy for the mitigation of summer heatwaves and the improvement of outdoor thermal comfort.
<p>D (Continental)</p> <p>Dfa:(Chen et al., 2021)</p>	<ul style="list-style-type: none"> • Changing the buildings' surface material resulted in no significant changes in microclimatic conditions. • The impacts of green roof and wind shelter on improving outdoor thermal comfort.

Results of analysis university campuses

A great majority of the research has selected more than three separate outdoor and semi-outdoor areas within a university (Salata et al., 2015, Salata et al., 2016, Du et al., 2017, Salata et al., 2017, Du & Mak, 2018, Shooshtarian & Rajagopalan, 2018, Taleghani, 2018, Aydin et

al., 2019, Ghaffarianhoseini et al., 2019, Altunkasa & Uslu, 2020, Lee et al., 2020, Brozovsky et al., 2021, Chen et al., 2021, Fawzy Abdulsalam & Haleem Hussien, 2021, Shata et al., 2021). Even though microclimatic studies were conducted in various climates, most of the universities were chosen in temperate climates (Salata et al., 2015, Salata et al., 2016, Du et al., 2017, Huang et al., 2017, Salata et al., 2017, Battisti et al., 2018, Du & Mak, 2018, Shooshtarian & Rajagopalan, 2018, Taleghani, 2018, Altunkasa & Uslu, 2020, Lee et al., 2020, Chen et al., 2021, Fang et al., 2021). It is popular to investigate the effects of geometry and material on outdoor thermal comfort during hot period (Salata et al., 2015, Du et al., 2017, Huang et al., 2017, Battisti et al., 2018, Shooshtarian & Rajagopalan, 2018, Taleghani, 2018, Aydin et al., 2019, Ghaffarianhoseini et al., 2019, Fang et al., 2021, Fawzy Abdulsalam & Haleem Hussien 2021, Shata et al., 2021). Some research however, has taken into account the effects of vegetation (Salata et al., 2016, Ghaffarianhoseini et al., 2019, Abdi et al., 2020, Altunkasa & Uslu, 2020).

Location selection criteria analysis for university campuses are visually summarized in Figure 2.7.

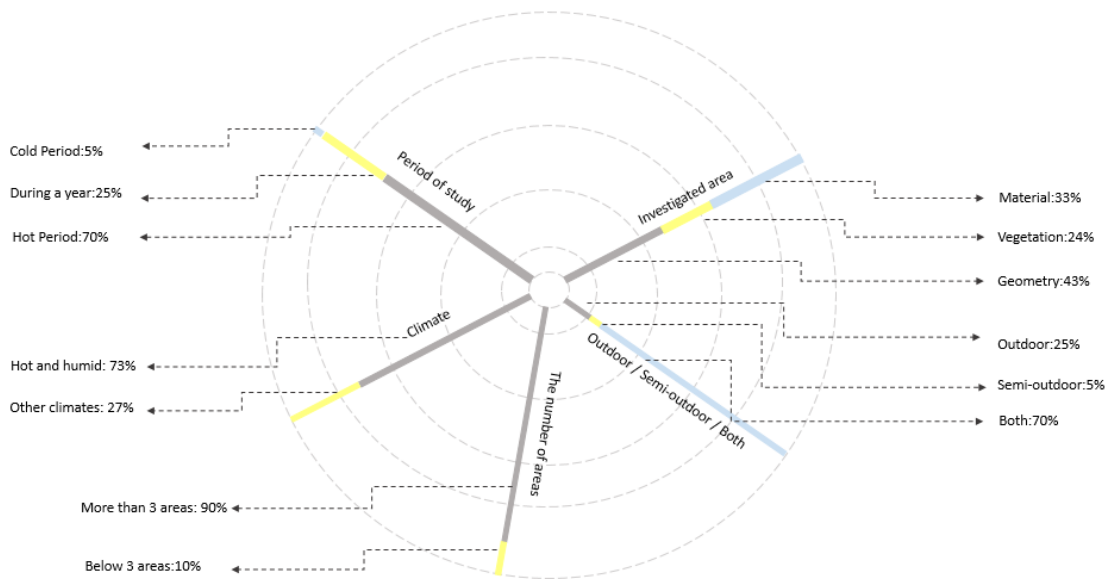

Figure 2.7 Location selection criteria analysis – university campuses

2.4.4 Public Squares and Urban Parks

Public squares and urban parks are common gathering places for people in cities, and many of them are regarded as both a symbol of the city and a tourist attraction (Cybriwsky, 1999). According to our criteria, 15 papers have focused on single urban parks or public squares and just 5 papers for multiple ones out of 20 papers. In Table 2.5, we classified all selected papers in this category. Based on the selected papers, urban parks and public squares can possess microclimates that differ from the surrounding areas due to factors such as vegetation, water features, and buildings. These areas are widely used by people, especially during the warm months, and it is essential to understand the microclimate and thermal comfort conditions in these spaces.

Table 2.5 The list of selected papers of public squares and urban parks based on Köppen climate classification and their achievements

Authors (2015-2022) – Focusing on software simulation & field measurements	
Different climate classifications	Achievements
A (tropical) Aw:(Johansson et al., 2018)	<ul style="list-style-type: none"> Local people accept thermal conditions which are above acceptable comfort limits in temperate climates and that the subjective thermal perception varies within a wide range.
B (Dry) Bwh:(Karimi et al., 2020)	<ul style="list-style-type: none"> There is a significant correlation between sky view factor and outdoor thermal comfort only during sunlight and sunset. The best thermal comfort condition can be reached by combining the low-albedo pavements, and trees with wide crowns and high trunks.
C (Temperate) Cfa: (Liu et al., 2016, Lu et al., 2017) Cfb:(Lam et al., 2018, Krüger et al., 2019, Chatzipoulka et al., 2020, Ahmadian et al., 2021, Hosseinzadeh & Keshmiri, 2021) Csa:(Martinelli et al., 2015, Nouri et al., 2018, Santos et al., 2018, Apreda et al., 2020)	<ul style="list-style-type: none"> The tree's mean nighttime cooling was significantly higher than the shelter. Sky view factor and LAI (Leaf index area) has less significant cooling effect due to the fact of dense-leaf season. Understanding the differences in visitors' thermal perception is important to improve the design. With the optimized arrangement of trees and using specific types of tree (e.g., birch), wind speeds at the pedestrian level are reduced. The wind velocity reduces when the crowns of the trees are located closer to the buildings and the ground. The importance of considering daily shading pattern when renovating open spaces. Trees can provide shade, which reduces the amount of direct sunlight and heat that reaches the ground. Plants release water vapor through a process called transpiration. This has a cooling effect on the surrounding air, and can help to reduce the temperature in urban areas.

Cwa:(Huang et al., 2015, Cheung & Jim, 2018, Lam & Lau, 2018, Wang et al., 2021)	
D (Continental)	<ul style="list-style-type: none"> • Shading devices like pavilions and shading meshes can be used in hot summers to prevent direct solar radiation to improve thermal comfort.
Dfa:(Brown et al., 2015)	<ul style="list-style-type: none"> • A negative correlation of the proportion of hardened ground with thermal comfort. Designers can use lawn or other kinds of vegetation to replace hardened ground to the largest acceptable extent.
Dfb:(Gál & Kántor, 2020)	
Dwa:(Sun et al., 2017)	<ul style="list-style-type: none"> • Trees and other vegetation can act as windbreaks, reducing wind speeds and creating a more comfortable microclimate.

Results of analysis single public squares and urban parks

Outdoor thermal comfort in a public square has been the subject of fewer investigations. Public squares in high-density, high-intensity areas are more popular (Huang et al., 2015, Martinelli et al., 2015, Lu et al., 2017, Sun et al., 2017, Cheung & Jim 2018, Johansson et al., 2018, Krüger et al., 2019, Apreda et al., 2020, Gál & Kántor, 2020, Wang et al., 2021), followed by squares in medium-density, medium-intensity regions (Lam et al., 2018, Nouri et al., 2018, Santos Nouri et al., 2018, Karimi et al., 2020, Hosseinzadeh & Keshmiri, 2021). Most research has looked at geometry and vegetation effects on over a year in temperate climates (Martinelli et al., 2015, Lu et al., 2017, Cheung & Jim, 2018, Lam et al., 2018, Nouri et al., 2018, Santos Nouri et al., 2018, Krüger et al., 2019, Apreda et al., 2020, Karimi et al., 2020, Hosseinzadeh & Keshmiri, 2021, Wang et al., 2021) because providing shade is so crucial in this location. The dimension of squares is varied in different case studies; however, most of the studies have focused on squares under 6000 m² (Huang et al., 2015, Martinelli et al., 2015, Lu et al., 2017, Lam et al., 2018, Santos Nouri et al., 2018, Apreda et al., 2020, Gál & Kántor, 2020, Karimi et al., 2020).

Location selection criteria analysis for single public squares and urban parks are visually summarized in Figure 2.8.

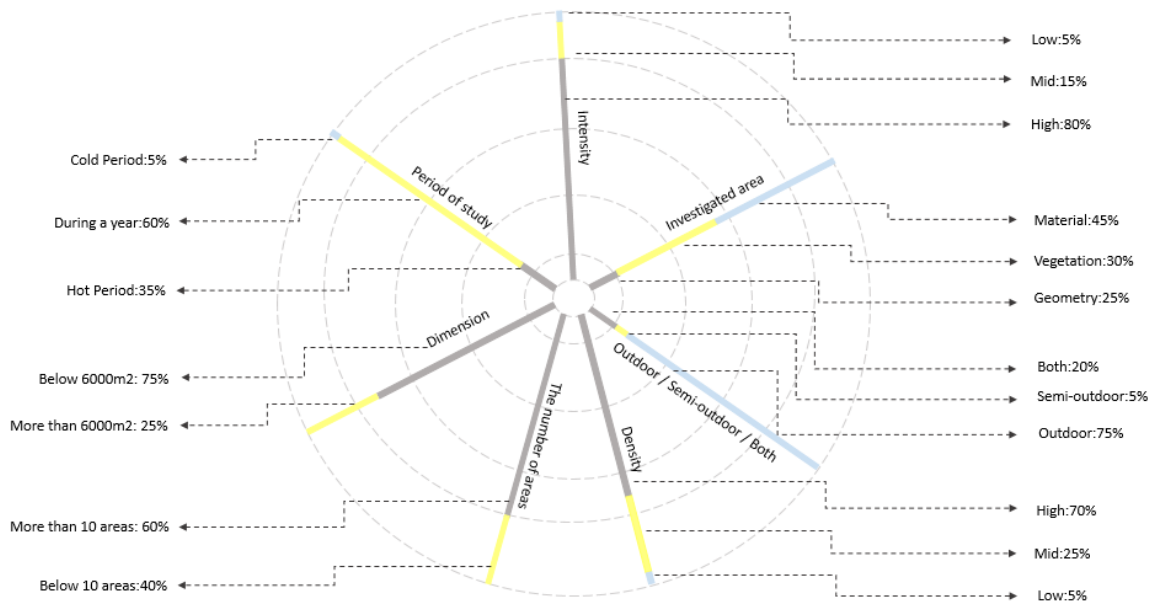

Figure 2.8 Location selection criteria analysis – single public squares and urban parks

Results of analysis multiple public squares and urban parks

Most of the studies have compared different areas in various cities of temperate climates (Liu et al., 2016, Lam & Lau, 2018, Chatzipoulka et al., 2020, Ahmadian et al., 2021). Some of these studies chose two cities in multiple countries to study outdoor thermal comfort in various climates throughout the year in temperate climates (Lam & Lau, 2018, Chatzipoulka et al., 2020). Furthermore, it is typical to select the most well-known public squares in multiple cities, analyse various architectural design and materials forms (Lam & Lau, 2018, Chatzipoulka et al., 2020, Ahmadian et al., 2021), and then select central parks to investigate diverse vegetation covering (Brown et al., 2015, Liu et al., 2016).

Location selection criteria analysis for multiple public squares and urban parks are visually summarized in Figure 2.9.

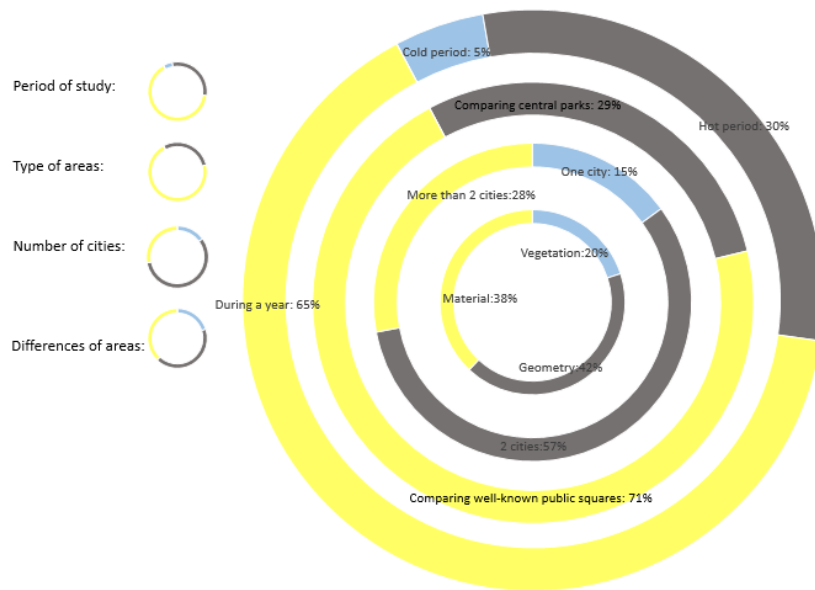

Figure 2.9 Location selection criteria analysis – multiple public squares and urban parks

2.4.5 Public Courtyards

Courtyards are vital architectural elements and have unique effects on their sounding space (Lau et al., 2014). According to our criteria, 5 papers have focused on single courtyards and just 4 papers for multiple ones out of 9 papers. In Table 2.6, we classified all selected papers in this category. Based on the selected studies, courtyards are often selected as a case study because they are surrounded by buildings or walls on all sides, creating an enclosed space. These areas are often used as outdoor spaces for socializing, relaxation, and other activities. Therefore, it is important to understand how the microclimate affects human comfort in these spaces.

Table 2.6 The list of selected papers of public courtyards based on Köppen climate classification and their achievements

Authors (2015-2022) – Focusing on software simulation & field measurements	
Different climate classifications	Achievements
A (tropical)	<ul style="list-style-type: none"> Green elements above 6 meters in the facade reduce significantly the impact at pedestrian level.
Af: (Ghaffarianhoseini et al., 2015, Acero et	<ul style="list-style-type: none"> The implementation and dimensions of Vertical green systems as urban infrastructure to improve the outdoor thermal environment.

al., 2019, Acero et al., 2020)	<ul style="list-style-type: none"> • An abundance in the amount of vegetation the courtyard can achieve an acceptable level of thermal comfort.
B (Dry)	<ul style="list-style-type: none"> • Increasing the shaded areas to reduce the cooling loads in the summer. • Courtyard length-to-height ratio and plays an important role in the mechanical behavior of the air temperature in the courtyard.
Bwh: (Kedissa et al., 2016, Zamani et al., 2018)	
C (Temperate)	<ul style="list-style-type: none"> • Special mention is given to the high impact of trees and soil humidity and the contrasting effects of pavement albedo. • Height/width proportions appear to have a stabilizing effect over thermal comfort.
Cfb: (Simon et al., 2018)	
Csa:(Chatzidimitriou & Yannas, 2016, Martinelli & Matzarakis, 2017, López-Cabeza et al., 2018)	

Results of analysis single public courtyards

Traditional courtyards are popular types in different studies (López-Cabeza et al., 2018, Simon et al., 2018, Acero et al., 2020), followed by new courtyards surrounded by different building heights (Chatzidimitriou & Yannas, 2016, Acero et al., 2019). The majority of studies have looked at the effects of geometry and vegetation over a year temperate climates (Chatzidimitriou & Yannas, 2016, López-Cabeza et al., 2018, Simon et al., 2018, Acero et al., 2019, Acero et al., 2020), and a significant number of studies from all review studies have selected courtyards with square shapes and nearly 400 m² of area (Chatzidimitriou & Yannas, 2016, Acero et al., 2019, Acero et al., 2020).

Location selection criteria analysis for single public courtyards are visually summarized in Figure 2.10.

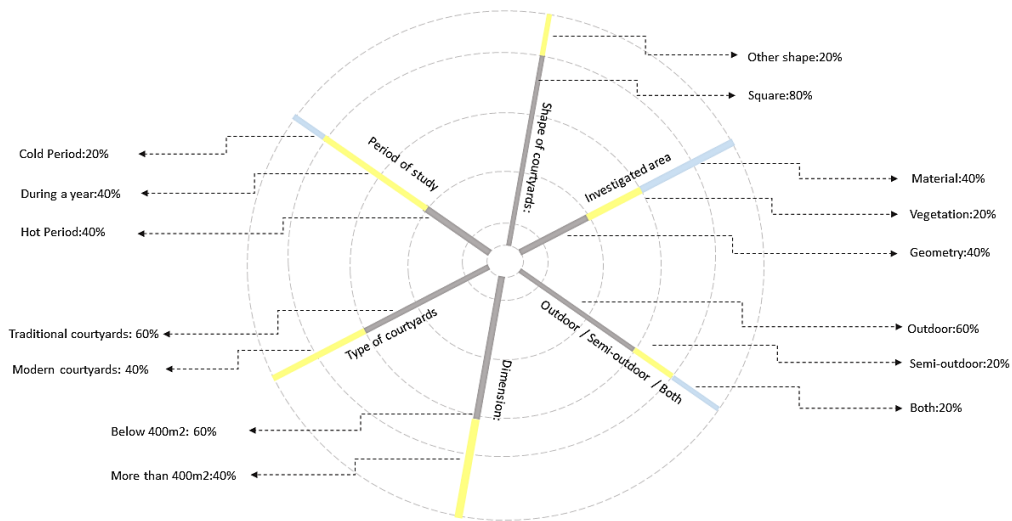

Figure 2.10 Location selection criteria analysis – single public courtyards

Results of analysis multiple public courtyards

A significant number of these studies chose courtyards with varying geometric characteristics and different vegetation covers during a year (Ghaffarianhoseini et al., 2015, Zamani et al., 2018). Fewer researchers have chosen courtyards in various climates (Martinelli & Matzarakis, 2017). Noticeably, in most of the studies from all review studies, courtyards are less than 400 m² (Ghaffarianhoseini et al., 2015, Kedissa et al., 2016, Martinelli & Matzarakis, 2017).

Location selection criteria analysis for multiple public courtyards are visually summarized in Figure 2.11.

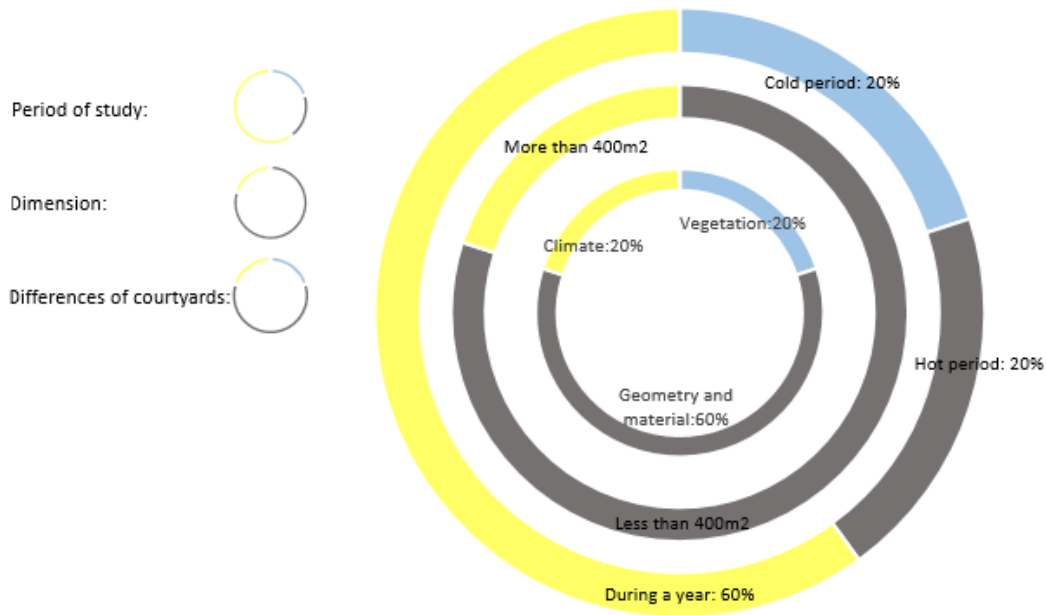

Figure 2.11 Location selection criteria analysis – multiple public courtyards

2.5 Discussion

This research aimed to establish a framework for future researchers in selecting study locations for urban microclimate research. The results identified neighbourhoods, urban streets, universities, urban parks, public squares, and courtyards as the most common typologies of locations utilized. The specific research results are achieved and visually summarized in Figure 2.12 for all types of locations. Upon analysing the criteria for selecting locations by previous researchers, future researchers can address the following recommendations to fill the identified gaps:

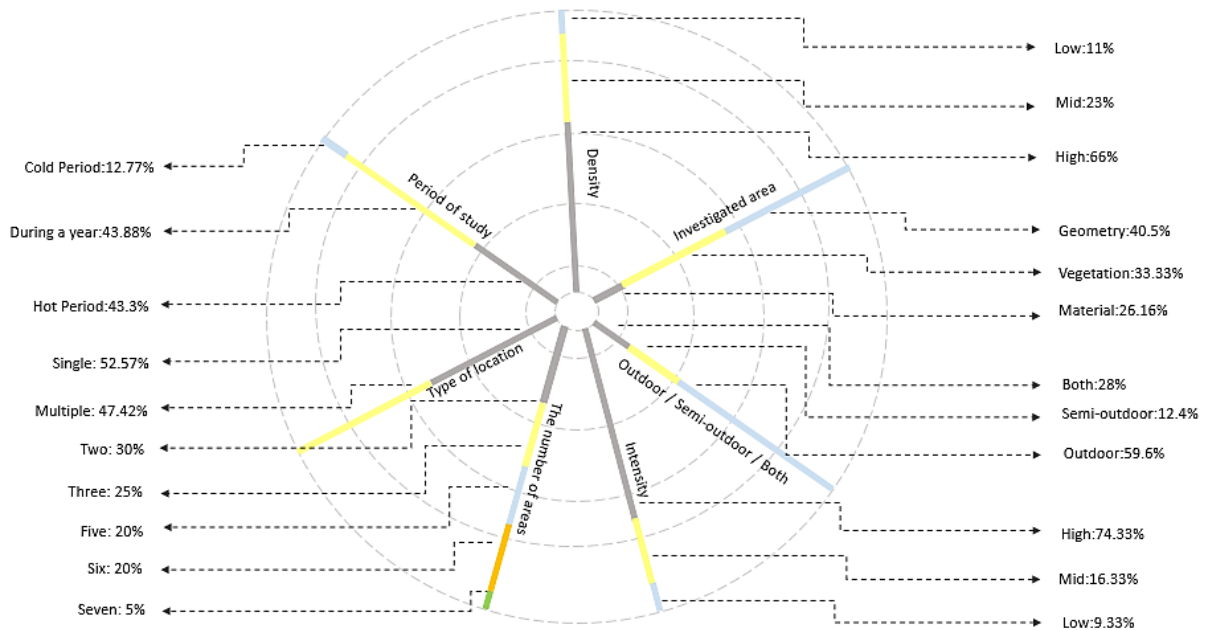

Figure 2.12 The most popular criteria for selecting locations

- **Single/ Multiple locations:** The majority of the reviewed urban microclimate research works emphasized a single location for their analysis rather than comparing multiple locations. However, comparing various locations may yield better solutions for improving the thermal conditions of areas, especially when selecting locations with different main features. For instance, analyzing microclimatic conditions in places with the same climates but varying materials or geometry, or selecting locations with similar design elements such as pavement and facade materials in various climates, can enhance our understanding of the relationship between climate and design factors. This, in turn, facilitates providing better outdoor thermal comfort and pleasant microclimate conditions.
- **Period of Study:** The majority of scholars conducted their research during summer (hot periods), followed by studies spanning the duration of a year. Nevertheless, there is a need to broaden the analysis of microclimatic conditions during cold periods to enhance livability and the quality of life in outdoor locations. Another crucial reason for

examining microclimate conditions during winter is the predicted climate change patterns worldwide. It is anticipated that temperatures will rise in various climates (Gasparri et al., 2017). Based on this assumption, analyzing the microclimate conditions of locations with cold winters, specifically cities with Dfb and Dfc climates based on the Köppen classification, becomes necessary. As these areas currently have a limited number of studies, it is essential to consider optimal urban designs now. This approach may enable these regions to provide better outdoor thermal comfort during winter in the future.

- **Area/ Dimension:** The majority of the selected locations had an area ranging between 3000 m² and 35000 m². While the impacts of urban heat islands and morphologies can be considered on a large scale (Liu et al., 2020), focusing on smaller areas allows for a more detailed analysis of microclimatic conditions in different parts of the locations. To be more precise, improving microclimate conditions and outdoor thermal comfort encourages people to spend more time outdoors, leading to positive impacts on energy efficiency in buildings. For example, by optimizing outdoor areas of educational and commercial complexes, people are encouraged to spend their leisure time outdoors, thereby reducing the energy use of indoor spaces.
- **Investigated Parameters:** Geometry has been the most investigated parameter, followed by vegetation. Majority of studies focus on more than one parameter. The significance of materials should be more considered in future research, as materials would play vital roles in optimization scenarios for improving outdoor thermal conditions. In more details, for defining new scenarios for locations that are constructed before and now we aim to improve microclimate and outdoor thermal conditions, altering geometry factors is the most challenging scenarios as these scenarios have needs in changing buildings shape most of the time, and adding new vegetations specially trees need

sufficient space, therefore changing pavement and façade materials can be considered as one of the most realistic scenarios that need to be investigated more in future research.

- **Outdoor/ Semi-outdoor:** The bulk of studies were performed on outdoor areas, followed by a combination of outdoor and semi-outdoor spaces. Analyzing thermal comfort in semi-outdoor places should be given more consideration in future studies, especially for locations with challenging climates such as hot and humid summers or cold winters. In these areas, designing semi-outdoor spaces can protect people from direct sun exposure during summer and from rain, and snow during winter. In windy locations, semi-outdoor areas can also shield people from unpleasant wind speeds. Therefore, future researchers should investigate the impacts of semi-outdoor areas on microclimate and outdoor thermal comfort conditions in more detail.
- **Density/ Intensity:** While high-density and high-intensity areas were the main points of focus in location selection, only a limited number of studies delved into low-density areas. Nevertheless, due to population growth, climate change, and the urban heat island effect, it is vital to analyze microclimatic conditions in medium and low-intensity/density areas. In more detail, as the population increases in different parts of the world, we will face more high-density areas in the future. Therefore, by analyzing microclimate and outdoor thermal comfort conditions in current scenarios, we can mitigate the negative impacts of urban designs in future scenarios, especially considering the predicted climate change.

2.6 Conclusions

This literature review focuses on the most prominent locations of previous microclimatic studies from 2015 to 2022. The results identified neighbourhoods, urban streets, universities, urban parks, public squares, and courtyards as the most common typologies of locations

utilized. While previous studies have examined a satisfactory range of locations, there are still other areas that could be investigated in future studies. To be more precise, for improving liveability in cities and encouraging people to spend more time outdoors, the microclimate and outdoor thermal comfort conditions of various location types should be considered. Improving outdoor conditions in various location types means decreasing energy use in buildings as well. Moreover, improving the outdoor thermal conditions and creating pleasant outdoor spaces have positive impacts on people's well-being.

The study also rigorously reviewed the criteria behind the selection of locations in urban microclimate studies, both in single and multiple cases. Previous researchers usually considered a defined range of criteria for selecting a location. The features that a location was selected can be divided into types of climates and defining a period of study, dimension of the location and its density and intensity, and selecting investigated factors that have a direct impact on microclimate and outdoor thermal comfort conditions of the selected location. Many previous researchers compared microclimate and outdoor thermal comfort conditions of various locations based on analysing similarities and differences criteria. Based on selected studies, analysing the impacts of geometry and greenery in high-density and intensity neighbourhoods of temperate climates was the most popular location type among researchers.

This study also investigated the number of microclimate and outdoor thermal comfort studies in different climate classifications. According the Köppen climate classification, Tropical (A), Dry (B), Temperate (C), and continental (D) are the main climate categories, in Figure 2.13 the selected papers are classified in different climate types.

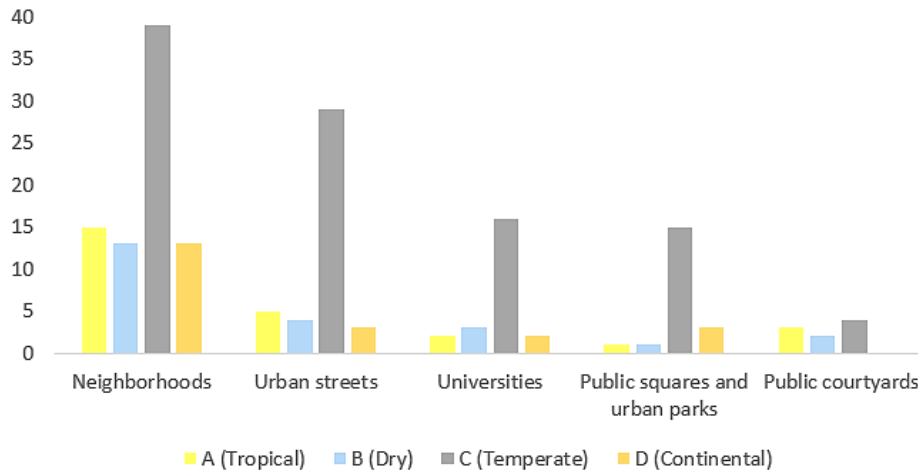

Figure 2.13 The number of selected papers in different climate types

Based on the selected papers for this review the following results are drawn:

- Over half of the selected documents (103 out of 173) were conducted in temperate regions. To elaborate further, investigating microclimatic conditions and outdoor thermal comfort in temperate climates across all location categories ranks as the highest priority. Previous studies have typically used various forms of greenery and geometry to improve thermal comfort in temperate climates, which often experience significant rainfall and can have both hot summers and cold winters, with temperature fluctuations occurring within a single day (Böcker et al., 2013).
- The assessment of microclimatic conditions and outdoor thermal comfort in tropical climates has been deemed equally significant by previous researchers as the analysis of these factors in dry climates, across all selected categories. To be more specific, 26 research papers were conducted in tropical climates followed by 23 research papers in dry climates. The climate challenges in tropical climates include high temperatures, humidity, and heat (Baruti et al., 2019). In dry climates, extreme temperatures with hot summers and cold winters, as well as drought, are common challenges (Rummukainen, 2012). Shading is a common technique used to reduce the amount of direct sunlight that

reaches buildings and outdoor spaces, which can be achieved through the use of trees and vegetation or building geometries in both tropical and dry climates. Additionally, materials with different ranges of reflection and absorption can be used in dry climates.

- A comparatively smaller subset of the chosen papers (21 out of 173) concentrated on continental climates. Out of the selected papers, 13 papers examined the microclimate and outdoor thermal comfort in neighbourhoods with continental climates, while only 8 papers conducted in urban streets, universities, urban squares, and urban parks located in areas with continental climates. Previous studies have employed strategies such as incorporating building geometries, using vegetation and shade, and implementing cool pavements to mitigate thermal discomfort in continental climates, which are known for their extreme temperature range with hot summers and cold winters (Mosbrugger et al., 2005).

To summarize, except for the temperate Csa climate category, which has 33 publications, there is a limited number of studies on microclimate and outdoor thermal comfort in other climate types. Some climate types, such as Am, are even considered neglected areas. Although there are various reasons for selecting locations, such as addressing high temperatures during summer in Csa cities, future researchers should focus on a wider range of climate types due to predicted climate change, the urban heat island phenomenon, and population growth. It is important to mitigate the impacts of urban designs on climate change and improve outdoor thermal comfort in various climate types. Architects and urban designers should take these factors into account when developing new designs that aim to enhance outdoor thermal conditions.

Chapter 3 An assessment of existing microclimate and outdoor thermal comfort studies in temperate oceanic (Cfb) cities- A systematic review

3.1 Prelude

Chapter 2 focused on analysing criteria for selecting locations for microclimate and outdoor thermal comfort studies, revealing significant gaps, particularly a limited number of studies in Cfb cities based on the Köppen climate classification. Chapter 3 extends this exploration to worldwide Cfb cities, uncovering that out of over 50 such cities, less than 45 meet criteria for microclimatic publications, with only 17 cities represented and an average of fewer than 3 papers per city. Despite evident research gaps, efforts to develop a comprehensive guideline are deemed challenging. Future studies must address critical gaps, emphasizing the need to broaden geographical investigations beyond residential neighbourhoods and urban streets to include diverse urban spaces. While existing studies often focus on the impact of greenery, it is crucial to recognize the roles of materials and geometry in determining microclimatic conditions. Adopting a more effective combined approach of field measurements and computer modelling is essential, and the predominant focus on summer underscores a critical gap, urging researchers to extend considerations to winter conditions in Cfb cities. Despite limited investigation, selected papers highlight mean radiant temperature and air temperature as key concerns, emphasizing the roles of vegetation cover, material albedo, and innovative use of building materials in mitigating microclimatic challenges.

3.2 Introduction

While nearly 55% of the world's population lives in urban areas (Vlahov et al., 2007, Buffel & Phillipson, 2016), this number is projected to increase to approximately 67% by 2050 (Passel & D'Veira Cohn, 2008, Huang et al., 2019). Continuous urbanizations mean more complex urban morphologies including a wide range of built density, layout, and forms (Taubenböck et

al., 2009, Song et al., 2018, Javanroodi & Nik 2019). Rapid urbanization has a vital role in increasing the urban heat island (UHI) effect (He et al., 2007, Hu & Jia, 2010, Singh et al., 2020), a phenomenon where urban areas have a higher temperature than rural areas, especially during warm periods (Yagüe et al., 1991, Alavipanah et al., 2015, Founda & Santamouris, 2017). The construction materials, the complex geometry of the urban contexts, and the reduction of greenery cover contribute to UHI effect (Emmanuel & Fernando, 2007, Aflaki et al., 2017, Lin et al., 2017, Mutani & Todeschi, 2020). The UHI effect has significant impacts on outdoor thermal comfort, air quality, and building energy consumption (Hong & Lin, 2015, Baniassadi et al., 2018, Taleghani, 2018). More than 400 cities around the world have reported findings about the UHI effect (Santamouris, 2020). UHI can have pronounced impacts on the health and wellbeing of city residents (Tan et al., 2010, Heaviside et al., 2017), outdoor thermal comfort, urban air quality, and building energy use, and it exacerbates the adverse effects of climate change (Golden, 2004, Taleghani et al., 2015, Marando et al., 2019).

Moreover, during the past decades, urbanization leads to changes in the morphology of cities (Denis & Marius-Gnanou, 2010, Zhou & Chen, 2018); more complicated microclimate conditions result from complex urban areas with various urban densities, layout typologies, and different architectural forms (Strømman-Andersen & Sattrup, 2011, Ng et al., 2012, Natanian et al., 2019, Heris et al., 2020). Microclimatic conditions affect design strategies of cities, energy performance of buildings, as well as urban climate comfort (Tan et al., 2016, Zinzi et al., 2018, Javanroodi & Nik, 2019, Mauree et al., 2019). The correlation between microclimate and outdoor thermal comfort has become a popular topic in urban research (Nikolopoulou et al., 2001, Nikolopoulou & Steemers, 2003, Fang et al., 2017). Thermal comfort is the ‘condition of mind that expresses satisfaction with the thermal environment and can be assessed by subjective evaluation (Ali-Toudert & Mayer, 2006, Johansson, 2006, Li et al., 2016). The level of outdoor thermal comfort is influenced by physical factors, namely air

temperature, relative humidity, solar radiation, wind speed, and personal and social factors, including a resident's sex, age, metabolism, residence time, emotional status, cultural background, environmental attitude, and clothing (Huang et al., 2017, Rosso et al., 2018, Cheung & Jim, 2019, Elnabawi & Hamza, 2019).

Because of the issues related to climate change and the UHI phenomenon, a significant number of research studies have focused on analysing the microclimatic conditions of various urban contexts around the world for improving the level of outdoor thermal comfort (Ramyar et al., 2019, Rosso et al., 2022). For example, synthesizing recent literature, (Aghamolaei et al., 2023) pinpointed key parameters for a comprehensive Outdoor Thermal Comfort (OTC) assessment framework, shaped by environmental and user-related factors. (Lin & Brown, 2021) explored strategies in landscape architecture to optimize thermal comfort in outdoor spaces, while (Zhao et al., 2021) delved into adaptive thermal comfort models, concentrating on data-driven techniques for both indoor and outdoor environments. (Aghamolaei & Lak, 2023) provided insights into variations in sensations and preferences among different age groups, particularly the elderly, and (Jamei et al., 2016) explored the impact of urban greening and building geometry (Johansson & Emmanuel, 2006) underscored the standardization of subjective assessment tools in field studies outdoors, while (Chen & Ng, 2012) specifically investigated the experiences and perceptions of pedestrians in studies on outdoor thermal comfort. (Nouri, 2018) assessed approaches to identify local thresholds for outdoor thermal comfort in urban design. Concurrently, (Azevedo & Leal, 2017) evaluated current climate and comfort policies, (Taleghani, 2018) studied strategies to mitigate urban heat island effects, and (Lai et al., 2019) investigated the cooling effects of various mitigation strategies.

According to Köppen(1936) climate categorization (Beck et al., 2005), which is one of the most widely used climate systems (Beck et al., 2005, Beck et al., 2018), climates in the world

are divided into five primary groups based on seasonal precipitation and temperature trends (Köppen, 1884, Chmielewski et al., 2011). As shown in Table 3.1, A (tropical), B (dry), C (temperate), D (continental), and E (polar) are the five primary types (Köppen, 1936). The main climatic groups are determined by the types of vegetation that thrive in each climate classification region (Kottek et al., 2006, Almeida et al., 2021). The second letter in the classification denotes the type of seasonal precipitation, whilst the third letter indicates the degree of heat (Chen & Chen, 2013).

Table 3.1 Climate types according to Köppen (Kottek et al., 2006, Beck et al., 2018)

Group	Second letter code	Third letter code
A-Tropical	f (Rainforest)	
	m(Monsoon)	
	w (Savanna, Dry winter)	
	s (Savanna, Dry summer)	
B-Dry	W (Desert)	h(Hot)
	S (Steppe)	k(Cold)
C-Temperate	w (Dry winter)	a (Hot summer)
	f (No dry season)	b (Warm summer)
	s (Dry summer)	c (Cold summer)
D-Continental	w (Dry winter)	a (Hot summer)
	f (No dry season)	b (Warm summer)
	s (Dry summer)	c (Cold summer)
		d (Very cold winter)
E-Polar	T (Tundra)	
	F (Eternal frost (ice cap))	

Microclimatic studies have been the focus of a great deal of recent research in the various

Köppen climate classification; according to Dimensions, Web of science, and google scholar, over 2700 scholarly works have focused on investigating “Microclimate” in built environment and design since the beginning of these research types (from 1985), and more than half of these studies were published within the past 10 years (2012-2022) as shown in Figure 3.1.

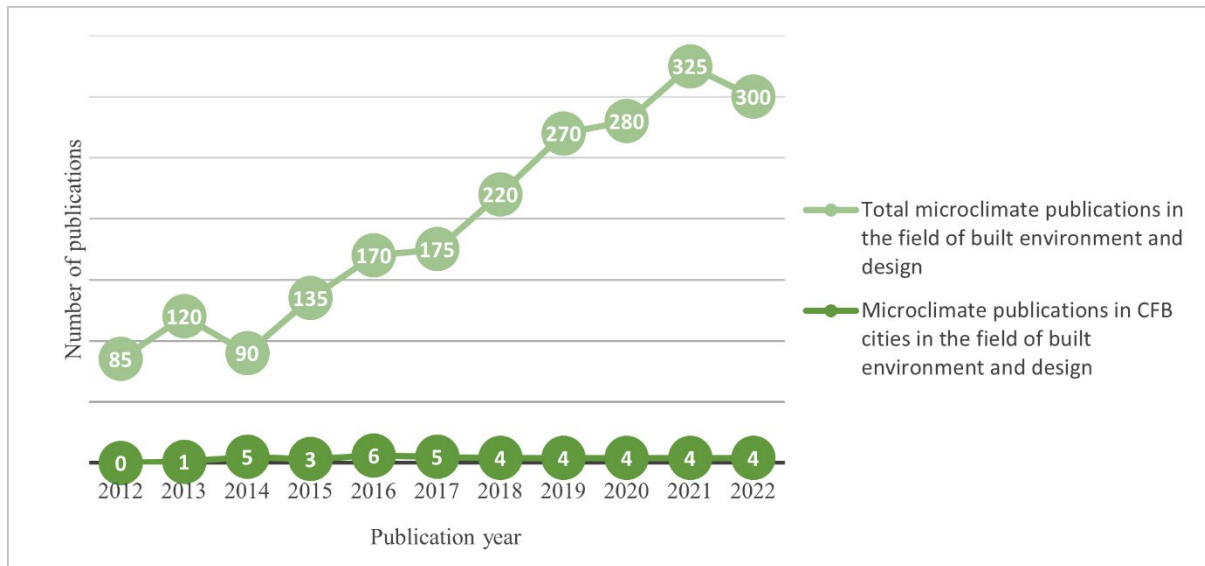

Figure 3.1 Microclimate publications in the field of built environment and design from 2012 to 2022 (The dimensions and Web of Science search results were included in this figure)

According to Dimensions and as displayed in Figure 3.2, the number of microclimatic publications in the field of the built environment and design, based on Köppen climate classifications, indicates that most of the previous research has been carried out in dry climates, with 1253 publications, followed by microclimatic research in tropical climates, with 868 publications. Only 2% of previous microclimatic research in temperate climates has been carried out in Cfb cities; a significant number of studies in temperate climate have been conducted in monsoon-influenced humid subtropical climates (Cwa) and cold-summer Mediterranean climates (Csc).

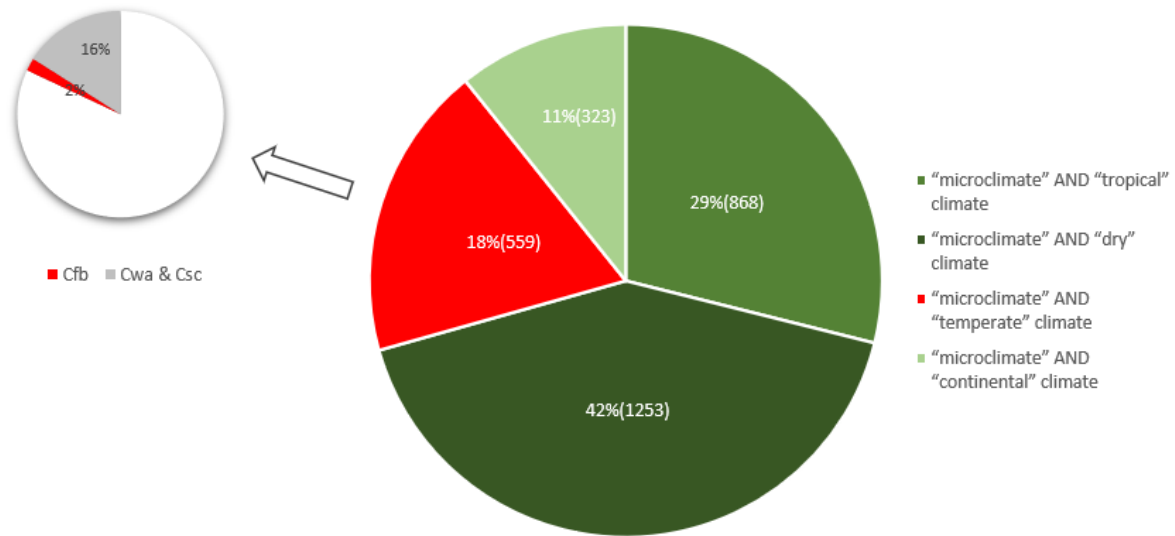

Figure 3.2 The number of microclimatic publications in different Köppen climate classification

The outcomes of this review demonstrate gaps in urban microclimate research in Cfb cities and lay the groundwork for future research on neglected yet significant aspects of the urban microclimate.

The Cfb climate classification signifies a temperate oceanic or maritime climate. Summer temperatures range from mild to warm, averaging above 10°C, while winter temperatures are cool to cold, with averages below 18°C in the coldest month (Steenefeld et al., 2010, Bozzhigitov et al., 2022). Precipitation is evenly spread across the year, without a distinct dry season (Bozzhigitov et al., 2022). Typically, regions with Cfb climates encounter mild, damp winters and cool, pleasant summers (Baquero & Forcada, 2022). Therefore, based on the climate conditions of these areas, it seems that microclimate challenges and outdoor thermal discomfort are not the critical issues that need to be addressed immediately. However, population growth pressure and various reports of future climate change predictions (Salimi Turkamani, 2021, Currie & Clarke, 2022) may have an impact on Cfb cities' microclimate. For example, Auckland, New Zealand, currently has a population of 1.66 million people, and it is

anticipated to increase by 720,000 to 2.4 million in the next 30 years (Source: Auckland City Council). Furthermore, temperatures are projected to increase in the future, and extreme weather events, such as heatwaves and extremely high temperatures, are also likely to become more common in Auckland (Eames, 2017). In London, another Cfb city, the population is expected to reach 9.8 million people by 2043, representing an increase of 800 thousand people compared to 2021 (Source: London Council). London's summers are expected to become hotter and drier; by the middle of the century, an average summer is projected to be a fifth drier, with an average summer day being 3°C warmer (Source: London Council). The forecasts indicate that by 2041, the number of people living in the City of Melbourne is expected to double, reaching over 308,000. Melbourne is already experiencing hotter days, currently averaging 11 days with temperatures greater than 35 degrees. By 2050, Melbourne is expected to experience an average of 16 days with temperatures exceeding 35 degrees (Source: City of Melbourne).

Consequently, a deeper comprehension of the microclimatic conditions in these areas is required. The significance of considering the urban microclimate in strategies for people's adaptation to and mitigation of various factors, as well as for the future development of urban areas in Cfb cities, is emphasized. Additionally, modifications to the urban microclimate have significant impacts on the energy efficiency of the built environment, as well as on the happiness and well-being of city residents. The location of the Cfb climate zone on the world map is shown in green colour in Figure 3.3.

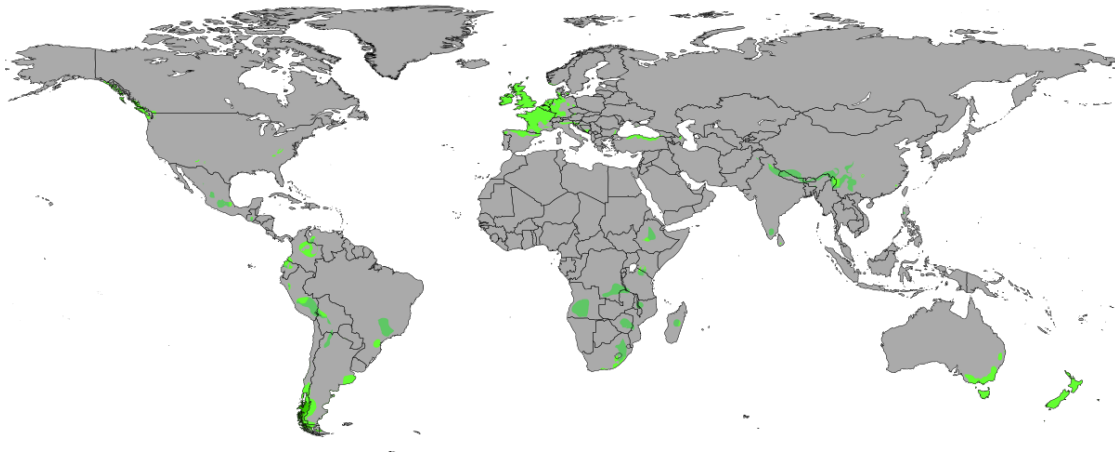

Figure 3.3 Temperate oceanic (Cfb) areas around the world (Beck et al., 2018)

This paper aims to provide a review of existing studies on the urban microclimate in temperate oceanic (Cfb) cities. The objectives of this study are: 1) to present an overview of existing studies on urban microclimate and outdoor thermal comfort in Cfb cities, 2) to highlight gaps in urban microclimate studies in Cfb cities, and 3) to provide recommendations for neglected but critical aspects of urban microclimate for future studies in Cfb cities. Urban planners and those responsible for developing climate change policies in Cfb regions will gain an improved understanding of the impact of urban microclimate from the findings.

3.3 Methodology

The objectives of the research were attained through three logical steps. First, establishment of research objectives as mentioned in introductory section. This was followed by identification and collection of relevant studies reported in the literature review based on inclusion and exclusion criteria. Data emerging from second step was then processed, charted, analysed, and finally summarised and reported as the findings in this review paper.

The selection of a database is of crucial importance in conducting scientific reviews due to its direct impact on the quality of findings (Kaynak, 2003). Dimensions- a scientific research database- is a cutting-edge and innovative, linked research data infrastructure and tool, re-

imagining discovery and access to research: grants, publications, citations, clinical trials, patents, and policy documents. It provides access to over 106 million publications and has over 1.2 billion cited references across many disciplines. Due to its scientific integrity and completeness, the Dimensions has been selected in the current paper as the main database for extracting publication items.

To begin, a search syntax was created to include phrases associated with the concept of "Microclimatic studies." To do this, the search string was created utilizing terms like "Microclimate," "Microclimatic conditions," and "Microclimatic studies." These keywords were then combined with "The name of major Cfb cities" using Boolean operators ("AND") to create the search query that was used to access the Dimensions database and acquire the essential data (The major cities considered for this review have been classified in Table 2). To eliminate out papers unrelated to the goals of this study, various filters were applied. First, only articles were included in the search because of their thoroughness and reputation as "certified knowledge" (Olawumi & Chan, 2018). Second, publications written in non-English languages were excluded. Third, resources unrelated to the building and environment were excluded. The exploration of the database occurred from October to December 2022, utilizing keywords derived from the logic grid within publication titles, keyword lists, and abstracts. Initially, 37 documents met the set criteria. To ensure comprehensive coverage, similar keywords were employed in searches on supplementary scholarly platforms such as Science Direct, Web of Science, and Google Scholar (in case some content was not indexed by Dimensions). Upon confirming the absence of duplicates, the located resources were cross-referenced with the initial database and deemed eligible for inclusion. This iterative process resulted in the incorporation of seven more articles into the preliminary database. Additionally, a second search was conducted through the reference lists of the chosen publications to identify related papers that may have been missed in the initial database search, yielding four more papers for

full-text screening. Consequently, the total count of identified items reached 43 (Figure 3.4).

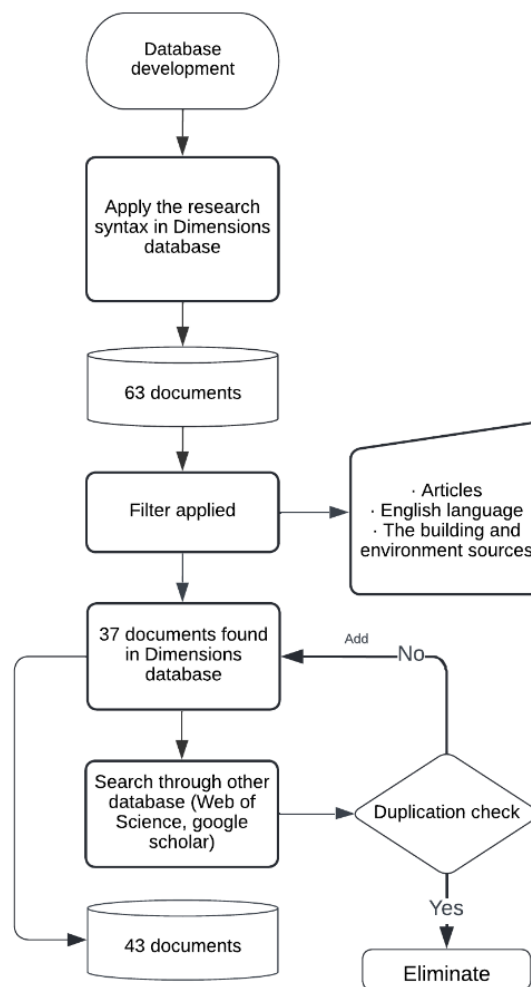

Figure 3.4 Methodological process

Based on selected papers, London has the most microclimatic studies with 10 papers, and Melbourne, Australia, comes in second with 7 papers. In Table 3.2, the number of papers in other Cfb cities has been illustrated; 27 Cfb cities do not have any microclimatic papers. Figure 3.5 displays the map of microclimatic papers in Cfb cities around the world.

Table 3.2 The number of papers in various Cfb cities

Cfb cities with more than 4 publications:	Cfb cities with between 1 and 3 publications:	Cfb cities without publications:
Melbourne, Australia	Vienna, Austria	Graz, Austria
London, UK	Antwerp, Belgium	Canberra, Australia

Curitiba, Brazil	Brussels, Belgium
Prague, Czechia	Sofia, Bulgaria
Cuenca, Ecuador	Bogota, Colombia
Lyon, France	Copenhagen, Denmark
Toulouse, France	Quito, Ecuador
Munich, Germany	Bordeaux, France
Stuttgart, Germany	Paris, France
Budapest, Hungary	Strasbourg, France
Amsterdam, Netherlands	Düsseldorf, Germany
Bilbao, Spain	Frankfurt, Germany
Lausanne, Switzerland	Hamburg, Germany
Zurich, Switzerland	Dublin, Ireland
Manchester, UK	Luxembourg, Luxembourg
	Utrecht, Netherlands
	Auckland, New Zealand
	Simferopol, Russia
	Donostia-San Sebastian, Spain
	Geneva, Switzerland
	Bratislava, Slovakia
	Bangor (North Wales), UK
	Birmingham, UK
	Brighton, UK
	Edinburgh, UK
	Glasgow, UK
	Santa Fe, USA

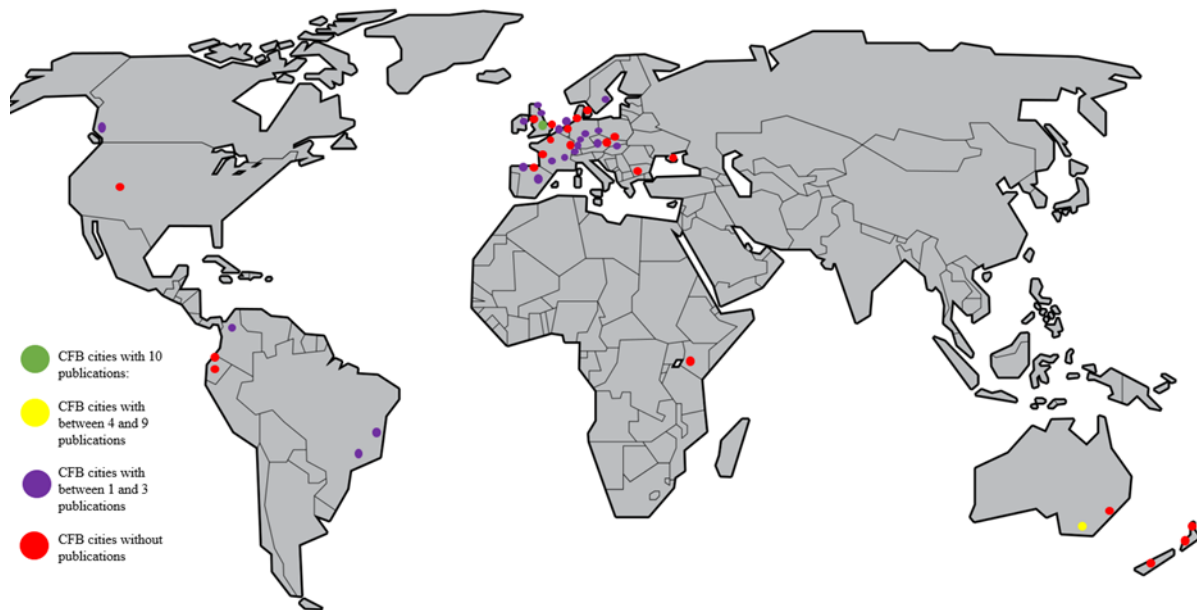

Figure 3.5 The map of microclimatic papers in Cfb cities around the world

3.4 Critical analysis of microclimatic studies in Cfb cities

In the following, previous microclimatic studies in Cfb cities are analysed based on city classifications. In this research, cities with more than four papers, namely London, and Melbourne are considered the main Cfb cities in microclimatic studies and are analysed in detail.

3.4.1 London

London has Cfb climate, the average temperature for the year in London is 10.3°C. The warmest month, on average, is July with an average temperature of 17.3°C. The coolest month on average is January, with an average temperature of 4.3°C (Source: Weather Spark). Based on our criteria, a total 10 microclimatic papers were found in London.

Table 3.3 The number of microclimatic papers in London

	Year	Location	Method of study	Period of study	Investigated factors	Achievements
London (Salvati et al., 2022)	2022	Residential area	Field measurements and Envi-met and energy plus	Summer	Material impacts on microclimate	Increasing high albedo material for walls in wide canyons with more road reflectivity
London (Hosseinzadeh & Keshmiri, 2021)	2021	Urban Park	Field measurements and Solid works	Summer	Greenery impacts on microclimate	Wider-crowned trees or placing trees closer to the edge of buildings for mitigating wind speed
London (Salvati & Kolokotroni, 2020)	2020	Residential area	Field measurements and Envi-met	Summer	Material impacts on microclimate	Reducing façade's albedo decrease heat stress level
London (Gunawardena et al., 2019)	2019	Residential and commercial neighborhood	Field measurements and urban climate model	Summer	Material impacts on microclimate	Using lightweight materials for decreasing thermal stress
London (Kwon et al., 2019)	2019	Street	Ecotect and Ryman and WinAir 7 Daysim	One year period	Geometry impacts on microclimate	Using flexible canopy for decreasing solar radiation in summer and permitting sunlight in winter
London (Taher et al., 2019)	2019	Street	Field measurements and Envi-met	Summer	Greenery impacts on microclimate	More trees generally have a considerable impact on thermal comfort, followed by live façades
London (Solera Jimenez, 2018)	2018	University campus	Field measurements	Summer	Greenery impacts on microclimate	Impacts of green facades for decreasing temperature
London (Cammelli & Stanfield, 2017)	2016	Residential area	Field measurements and BMT Fluid Mechanics	Summer	Greenery impacts on microclimate	Improving greenery for reducing wind speed
London (Shahrestani et al., 2015)	2015	Street	Field measurements	Summer	Geometry and greenery impacts on microclimate	Increasing vegetation's evapotranspiration effects for cooling
London (Yannas, 2001)	2001	Residential area	Field measurements	Summer	Geometry impacts on microclimate	Increasing aspect ratio mean decreasing thermal stress

Referring to Table 3.3 it can be concluded that in London, many of microclimatic research works have concentrated on the UHI effect (Yannas, 2001, Solera Jimenez, 2018, Gunawardena et al., 2019, Kwon et al., 2019, Taher et al., 2019, Salvati & Kolokotroni, 2020, Salvati et al., 2022). According to earlier research, the mean radiant temperature and air temperature are the key issues in the future (Taher et al., 2019, Salvati & Kolokotroni, 2020). As a result, attention has been given to the albedo of materials for pavements, facades, and vegetation. Utilizing low albedo (Salvati & Kolokotroni, 2020), lightweight materials (Yannas, 2001) as well as increasing vegetation cover, especially green façades (Solera Jimenez, 2018, Taher et al., 2019), were suggested as ways to mitigate the rise in mean radiant temperature and air temperature. The other option was to design high-rise buildings to shield them from direct sun radiation (Shahrestani et al., 2015).

In other papers (Shahrestani et al., 2015, Cammelli & Stanfield, 2017, Hosseinzadeh & Keshmiri, 2021), wind speed in various urban settings has been studied. To reduce wind, increasing vegetation cover (Shahrestani et al., 2015, Cammelli & Stanfield, 2017), especially trees (Hosseinzadeh & Keshmiri, 2021), is important. The other option was to make streets that ran parallel to the direction of the wind to lessen wind speed (Shahrestani et al., 2015).

Results of microclimatic studies in London:

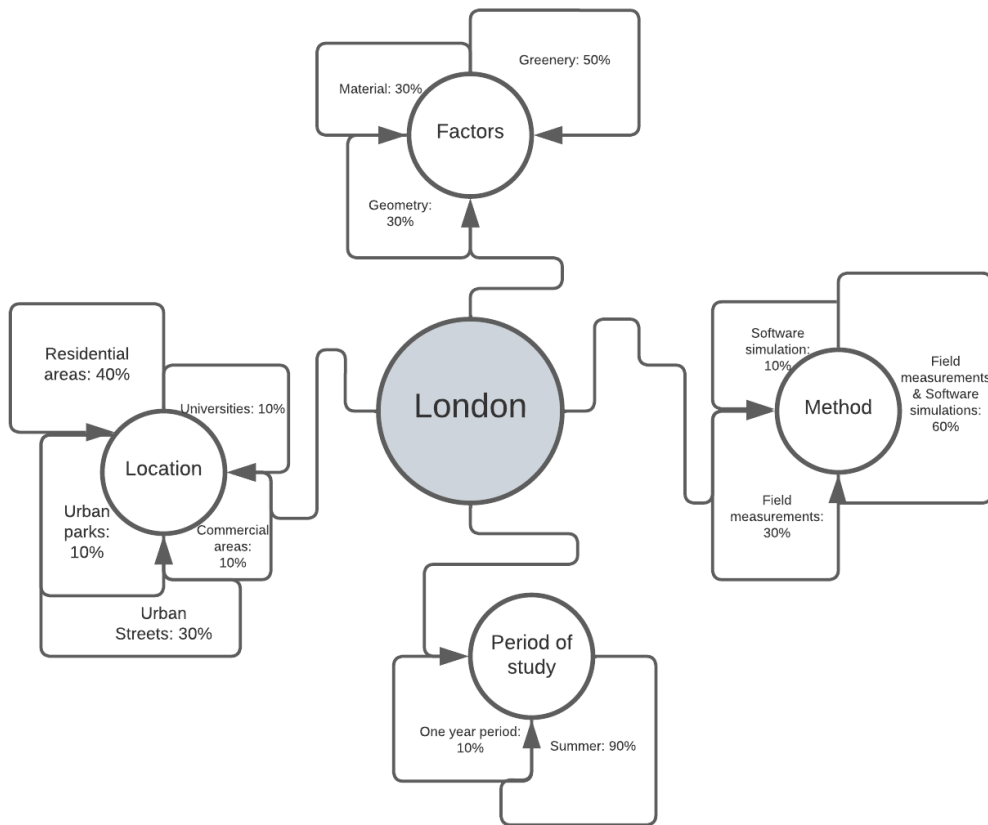

Figure 3.6 Results of microclimatic studies in London

According to Figure 3.6, based on the papers analysed, most of the previous microclimatic papers in London have focused on greenery especially in residential areas during summer. The method of study for about 60% of papers was both field measurements and software simulations. The research gap for microclimatic studies in London is classified into the following:

- Analysing microclimatic conditions in less investigated areas such as urban parks and squares as well as commercial parts of the city
- Analysing microclimatic conditions and the level of outdoor thermal comfort during winter
- Focusing on various variables together for example analysing geometry, material, and vegetation effects for the research instead of focusing on one variable

- For geometric aspects, analysing various orientations and the impact of sky view factors

3.4.2 Melbourne

Melbourne has a Cfb climate, and the average temperature for the year is 14.4°C. The warmest month, on average, is January, with a mean temperature of 20°C. The coolest month, on average, is July, with an average temperature of 8.9°C (Source: Weather Spark). Based on our criteria, a total 7 microclimatic papers were found for Melbourne climate.

Table 3.4 The number of microclimatic papers for Melbourne Climate

	Year	Location	Method of study	Period of study	Investigated factors	Achievements
Melbourne (Balany et al., 2022)	2022	Residential area	Field measurements and Envi-met	Summer	Greenery and blue infrastructure impacts on microclimate	The impacts of trees on reducing air temperature are significantly more important than green roofs and walls the effect of water only being felt up to a certain distance away from the fountain
Melbourne (Ng et al., 2020)	2020	Residential area	Field measurements and Envi-met	Summer	Greenery and geometry impact on microclimate	Green areas have low temperatures in all hours against of high-rise areas
Melbourne (Motazedian et al., 2020)	2020	Urban Park	Field measurements	Summer	Greenery impacts on microclimate	The impact of sky view factor and distribution of vegetation on cooling in nights
Melbourne (Jamei & Rajagopalan, 2019)	2018	Residential and commercial area	Field measurements and Envi-met	Summer	Geometry and greenery impact on microclimate	Increasing aspect ratio for decreasing air temperature E-W orientations have the worst thermal comfort level, improving shading in these orientations with buildings and trees
Melbourne (Sharifi & Boland, 2018)	2018	Residential area	Field measurements and field observation	Summer	Human thermal perceptions	The crucial zero-activity threshold of 48°C may be extended by space designs, regional climatic assumptions, and flexible activity choices
Melbourne (Shooshtarian & Ridley, 2016)	2016	University campus	Field measurements and questionnaires	Summer	Human thermal perceptions	The significant influence of a few human-dependent variables on outdoor thermal perceptions
Melbourne (Shooshtarian et al., 2015)	2015	Residential area	Field measurements and questionnaires	Summer/ Spring	Human thermal perceptions	Moderately to slightly comfortable conditions in the spring to just right to

Referring to Table 3.4 it can be concluded that analysing outdoor thermal comfort is crucial to microclimatic studies in Melbourne (Shooshtarian et al., 2015, Shooshtarian & Ridley, 2016, Sharifi & Boland, 2018, Jamei & Rajagopalan, 2019, Motazedian et al., 2020, Balany et al., 2022). Previous studies employed several outdoor thermal comfort indices (Shooshtarian et al., 2015, Jamei & Rajagopalan, 2019, Balany et al., 2022) and field measurements (Shooshtarian & Ridley, 2016, Sharifi & Boland, 2018, Motazedian et al., 2020) to address the urban heat island phenomenon and reduce heat stress in urban settings. The essential zero-activity threshold was 48°C (Sharifi & Boland, 2018), and both summer and spring were perceived as warm in terms of outdoor thermal comfort, with summer being notably warm in this regard (Shooshtarian et al., 2015). Increased green infrastructure was found to improve outdoor thermal comfort (Jamei & Rajagopalan, 2019, Motazedian et al., 2020, Balany et al., 2022), especially the effects of the tree-based scenario, which primarily reduces heat stress through evaporation and shadowing. The effects of green roofs and walls, however, were minimal.

Prior researchers recognized that the air temperature will drop as the aspect ratio is increased for the feature of geometry (Jamei & Rajagopalan, 2019, Balany et al., 2022). Additionally, Melbourne's E-W street orientations will experience the worst outdoor thermal comfort. To a certain distance, water features have effects on outdoor thermal comfort (Balany et al., 2022).

Results of microclimatic studies for Melbourne climate:

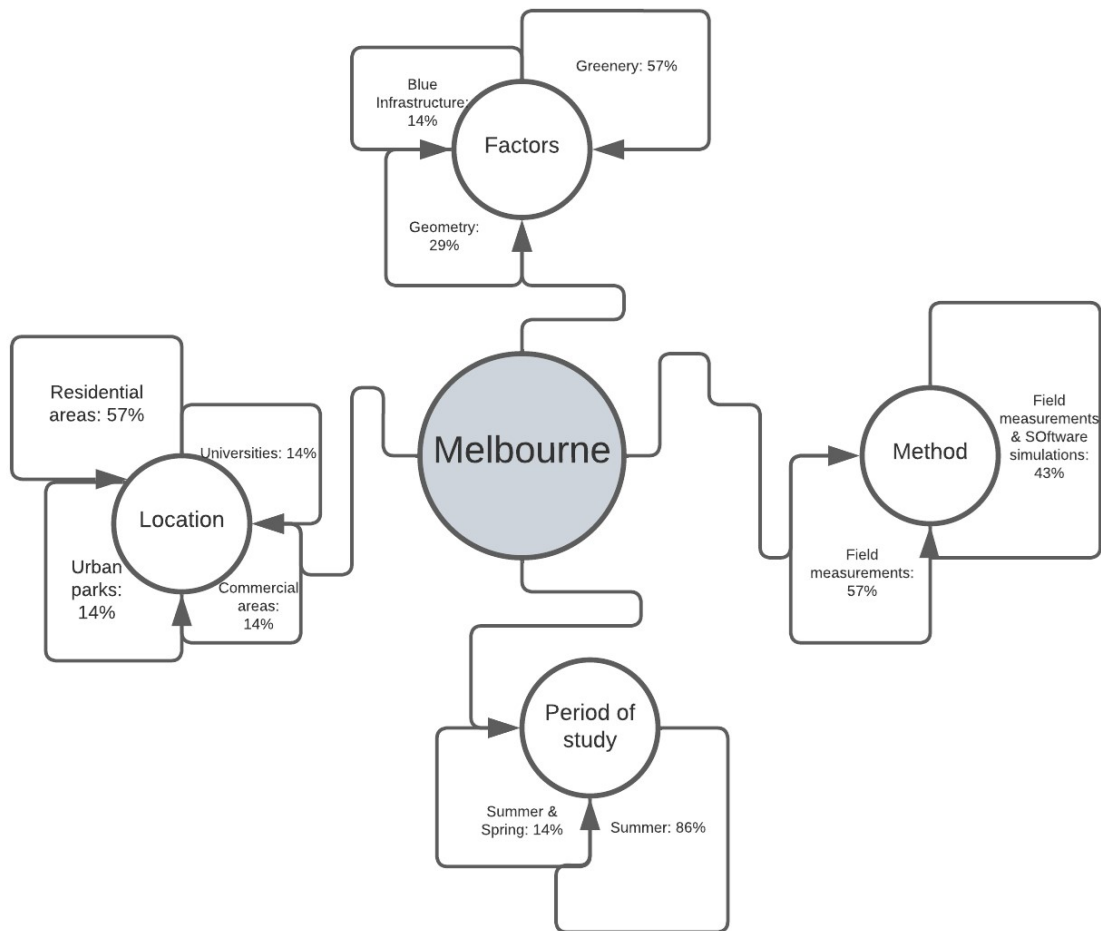

Figure 3.7 Results of microclimatic studies in Melbourne

According to Figure 3.7, based on the papers analysed, most of the previous microclimatic papers in Melbourne have focused on greenery especially in residential areas during summer. The method of study for about 60% of papers was field measurements. The research gap for microclimatic studies for Melbourne climate is classified into the following:

- Analysing microclimatic conditions in less investigated areas such as urban streets and squares
- Analysing microclimatic conditions and the level of outdoor thermal comfort during winter
- For improving the accuracy of results, using various software simulations with field measurements

- Analysing the impacts of materials in microclimatic studies

3.4.3 Other Cfb cities

In this section, we analysed the other Cfb cities under three microclimatic papers. The average temperature in a year for all following cities is between 8.3°C and 14.3°C (Source: Weather Spark). In the following, we analysed 26 microclimatic papers in these cities.

Table 3.5 The number of microclimatic papers in other Cfb cities

	Year	Location	Method of study	Period of study	Investigated factors	Achievements
Munich (Erlwein & Pauleit, 2021)	2022	Residential area	Field measurements and Envi-met	Summer	Greenery impacts on microclimate	Increasing greenery, specially trees for reducing air temperature and wind speed
Munich (Fleckenstein et al., 2022)	2022	Street	Field measurements and Ladybug	Summer	Material impacts on microclimate	Using self-shading façades for improving thermal comfort
Munich (Morille & Musy, 2017)	2017	Squares	Field measurements	Summer	Greenery impacts on microclimate	Increasing greenery, especially trees for reducing air temperature and wind speed
Stuttgart (Alsaad et al., 2022)	2022	Residential area	Field measurements and Envi-met	Summer	Greenery impacts on microclimate	The impacts of façade greenery on the mean radiant temperature
Amsterdam (Taleghani, 2018)	2018	Delft university	Field measurements and Envi-met	Summer	Material impacts on microclimate	High albedo materials mean increasing reflections and more solar radiation
Amsterdam (Klok et al., 2019)	2017	Park and street and square	Field measurements	Summer	Urban water and greenery impact on microclimate	Trees and buildings can reduce air temperature more than grass and water bodies by providing shading
Amsterdam (Kleerekoper et al., 2015)	2014	Residential area	Field measurements and Envi-met	Summer	Materials and greenery impacts on microclimate	A higher roof albedo & improving greenery is considered for cool strategy
Bilbao (Alvarez et al., 2021)	2021	Street	Field measurements and Envi-met	Summer	Greenery impacts on microclimate	Increasing high heat capacity soils for increasing thermal comfort
Bilbao (Lobaccaro et al., 2019)	2019	Residential area	Field measurements and Envi-met	Summer	Geometry and materials and greenery impacts on microclimate	The greatest impact of sun radiation on thermal discomfort on NE-SW orientations and effect of aspect ratio

Bilbao (Lobaccaro & Acero, 2015)	2015	Street	Field measurements and Envi-met	Summer	Greenery impacts on microclimate	Increasing trees, grass, and green roofs for improving thermal comfort
Vienna (Mitterboeck & Korjenic, 2017)	2017	Residential area	Field measurements and site observations	Summer	Greenery impacts on microclimate	Increasing greenery for reducing air temperature
Vienna (Maleki & Mahdavi, 2016)	2016	Residential area	Field measurements and Envi-met	Summer	Greenery and material impacts on microclimate	Adding more vegetation and permeable pavements can reduce air temperature
Vienna (Dimitrova et al., 2014)	2014	Street	Field measurements	Summer	Greenery impacts on microclimate	The evapotranspiration and shading effects of trees for reducing air temperature
Lausanne (Mauree et al., 2019)	2019	University	Field measurements and CitySim	One year period	Greenery impacts on microclimate	Increasing vegetation for improving evapotranspiration for decreasing air temperature
Zurich (Meili et al., 2021)	2020	Street	Field measurements	Summer	Greenery impacts on microclimate	Evapotranspiration of well-watered trees alone can reduce local air temperature
Zurich (Allegrini & Carmeliet, 2018)	2018	Residential and commercial area	Field measurements and Envi-met	Summer	Material and geometry impact on microclimate	The surface temperatures can be reduced by using building materials with high albedos
Budapest (Gál, 2014)	2014	Residential area	Field measurements and Envi-met and MATLAB	Summer	Greenery impacts on microclimate	Providing shading with trees for decreasing air and radiation temperature
Budapest (Gál, 2014)	2013	Residential areas	Field measurements and Envi-met and MATLAB	Summer	Geometry impacts on microclimate	Architectural forms have more impact on thermal comfort than orientations
Manchester (Skelhorn et al., 2016)	2016	Residential area	Field measurements and IES-VE	Summer	Greenery impacts on microclimate	Adding mature trees to reduce wind speed and air temperature
Manchester (Skelhorn et al., 2014)	2014	Residential & commercial areas	Field measurements and Envi-met	Summer	Greenery impacts on microclimate	Increasing greenery, specially trees for reducing surface temperature

Lyon (Morille & Musy, 2017)	2017	Residential areas	Field measurements and SOLENE	Summer	Greenery impacts on microclimate	Increasing greenery, especially trees for reducing air temperature
Toulouse (Martins et al., 2016)	2016	Residential areas	Field measurements and Envi-met	Summer	Greenery and water body impacts on microclimate	Green and water features had a significant impact on reducing urban heat islands, especially during the day
Antwerp (Toparlar et al., 2018)	2018	Urban Park	Field measurements and Ansys	Summer	Greenery impacts on microclimate	Decreasing wind velocity, increasing daytime cooling effects and night-time air temperature by planting more trees
Cuenca (Vásquez-Álvarez et al., 2022)	2022	Residential area	Field measurements and Envi-met	Summer	Material impacts on microclimate	The impacts of cooling materials on decreasing the land surface and the mean air temperature
Curitiba (Martini et al., 2020)	2020	Streets	Field measurements	One year period	Greenery impacts on microclimate	Increasing trees for improving thermal comfort
Prague (Jura et al., 2019)	2022	Residential area	Field measurements	One year period	Material and greenery impact on microclimate	Vegetation's evapotranspiration impacts on cooling

Referring to Table 3.5 it can be concluded that in Munich, the correlation between urban green space and outdoor thermal comfort shows the effectiveness of trees for improving outdoor thermal comfort by analysing PET (Morille & Musy, 2017, Erlwein & Pauleit, 2021). Moreover, climate resilient facades for creating self-shading result in reducing solar radiation as well as improving outdoor thermal comfort (Fleckenstein et al., 2022). For Stuttgart, analysing green walls reveals that the air temperature is not significantly affected by facade greening. However, an MRT reduction was noted. The relative humidity between the buildings was also impacted by green walls. The implementation of facade greening had only a slight effect on airflow between buildings (Alsaad et al., 2022). Microclimatic research in Amsterdam shows that the correlation between materials and outdoor thermal comfort shows an increase

in albedo of pavements resulted in more solar radiation reaching the ground (Taleghani, 2018), and a higher roof albedo and the utilization of greenery appear to be effective cooling strategies (Kleerekoper et al., 2015). Moreover, the effect of shaded areas by buildings and trees is more significant than grass and water bodies for PET reductions (Klok et al., 2019). Researchers in Bilbao indicate shaded areas as well as green areas such as grass, green roofs, and trees have significant impacts on improving outdoor thermal comfort (Lobaccaro & Acero, 2015, Alvarez et al., 2021). In all urban regions, the impact of solar radiation on thermal discomfort is greatest for a NE-SW orientation. The presence of trees in open-set high-rise urban environments may result in a meaningful reduction in heat stress at the pedestrian level. thermal discomfort (PET > 23 _C) are all significantly influenced by orientation and aspect ratio (Lobaccaro et al., 2019).

For Vienna, greenery covers near structures (Mitterboeck & Korjenic, 2017). Moreover, trees by increasing evaporations and shading effects can reduce thermal stress (Dimitrova et al., 2014).

It was shown that in Lausanne ground evaporative cooling can be a successful mitigation strategy for reducing locally the intensity of the urban heat island (Mauree et al., 2019). For Zurich, researchers state evapotranspiration of well-watered trees alone can reduce local air temperature (Meili et al., 2021). The surface temperatures can strongly be reduced by using building materials with high albedos, openings between buildings, or the presence of high-rise buildings in a lower building area can increase the ventilation and lead to lower local air temperature (Allegrini & Carmeliet, 2018). Investigating in Budapest release that Shading and semi-enclosure (i.e., the impact of courtyards) were found to be useful solutions for lowering daytime air and radiation temperatures (Gál, 2014). Architectural forms have more significant impacts than orientation, particularly in configurations with densely spaced-out structures and high site coverage (Gál, 2014). Studies in Manchester conclude that the mature trees have

significant impacts on decreasing air temperature and wind speed (Skelhorn et al., 2016) and replacing vegetation with asphalt results a major rise in air temperature especially at midday (Skelhorn et al., 2014).

While in Toulouse, Antwerp, and Curitiba green and water features had a significant impact on reducing urban heat islands, especially during the day (Martins et al., 2016, Toparlar et al., 2018, Martini et al., 2020), in Cuenca, by replacing asphalt pavements with concrete pavements the land surface temperature (LST) of the decreased (Vásquez-Álvarez et al., 2022). Moreover, for Prague and Lyon, natural surfaces with vegetation can decrease temperature noticeably, The evapotranspiration of the vegetation is what is causing the temperature drop, according to trends in absolute and relative air humidity as well as air temperature differences (Morille & Musy, 2017, Jura et al., 2019).

Results of microclimatic studies in other Cfb cities:

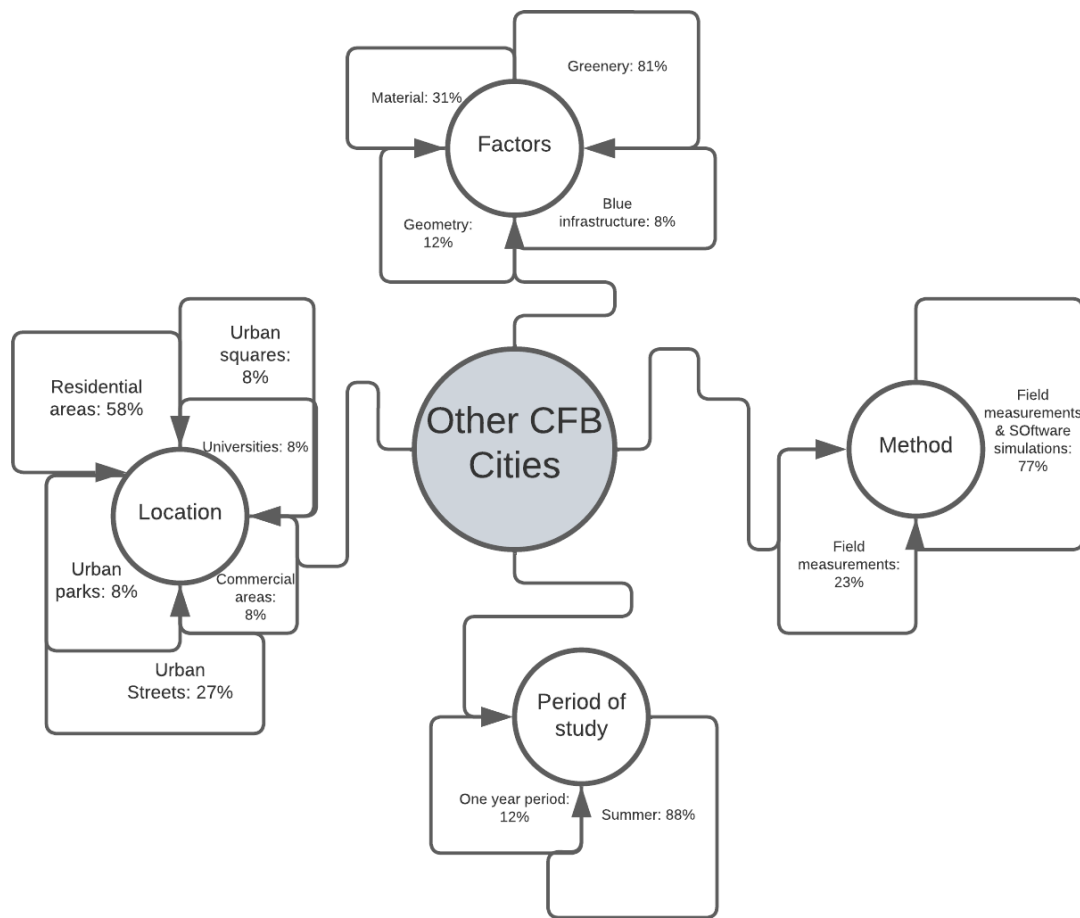

Figure 3.8 Results of microclimatic studies in other Cfb cities

According to Figure 3.8, based on analysed papers, most of the previous microclimatic papers in other Cfb cities have focused on greenery especially in residential areas during summer. The method of study for about 77% of papers was both field measurements and software simulations. The research gap for microclimatic studies in other Cfb cities is classified into the following:

- Analysing microclimatic conditions in less investigated areas such as urban parks, squares, universities, and commercial areas
- Analysing microclimatic conditions and the level of outdoor thermal comfort during winter

- Focusing on various variables together for example analysing geometry, material, and vegetation effects for the research instead of focusing on one variable
- For geometric aspects, analysing various aspect ratio and the impact of sky view factors

3.5 Discussion

This review of studies on previous urban microclimatic research in Cfb cities has revealed limitations in existing research concerning several key elements: locations, factors analysed, methods employed, and the study area. One of the most recurrent themes in the presented papers is the analysis of microclimatic conditions in residential areas during the summer, with a particular focus on greenery (Figure 3.9).

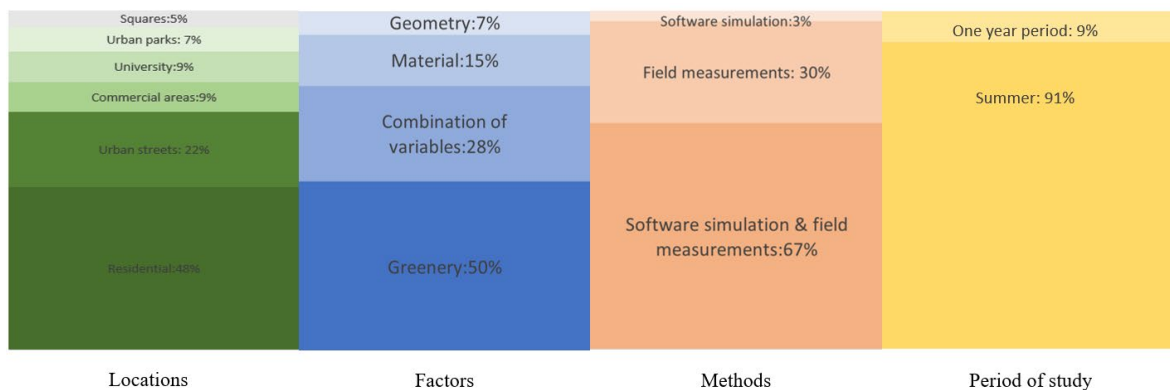

Figure 3.9 Results of microclimatic studies for all selected papers

The gaps in previous research that future studies should address to provide a comprehensive microclimatic guideline are listed below:

- Locations: As mentioned in the introduction section, climate change is predicted in different parts of the world, and research efforts should be dedicated to Cfb cities lacking microclimatic studies to adapt to predicted climate change patterns. Additionally, a reasonable number of prior studies have examined residential neighbourhoods and urban streets, areas that typically have high people exposure.

Future researchers can also explore urban spaces with a significant role in people gathering, such as commercial areas, urban parks, squares, and universities, across all selected Cfb cities. Providing comfortable outdoor areas not only enhances the liveability of cities but also encourages people to spend more time outdoors.

- Investigated factors: As the coverage of greenery in urban areas of Cfb cities is one of the crucial components in the urban context and previous studies have highlighted its vital role in providing outdoor thermal comfort and microclimatic conditions in selected locations, approximately half of the chosen studies analysed the impacts of greenery on microclimate. However, it's important to recognize that materials and geometry also play vital roles in determining microclimatic conditions. Future research that considers various factors is essential for obtaining more accurate results and defining optimal scenarios to create more comfortable outdoor areas. To elaborate further, previous research indicates that in dry and hot climates, outdoor thermal comfort conditions at street level strongly depend on aspect ratio and street orientation (Ali-Toudert & Mayer, 2006). In tropical climates, optimal outdoor thermal comfort levels are observed on streets with high aspect ratios and a north-south orientation (Acero et al., 2021). Additionally, based on previous studies on material impacts, it is concluded that highly reflective materials not only reduce air temperature in urban open spaces but also increase the re-radiation of the sun onto pedestrians (Taleghani, 2018). Therefore, future studies should conduct a more in-depth investigation into the impacts of materials as well.
- Method of study: nearly one-third of the selected papers relied solely on field measurements in their studies. However, based on previous research, the most effective approach for studying microclimates involves a combination of field measurements and computer modelling. Specifically, field measurements have been employed to

investigate the impact of urban design on urban microclimate (Lai et al., 2019). Nonetheless, due to the limitations of the observational approach, their findings can only reflect the current conditions at a specific time and space. The simulation approach, on the other hand, has been utilized in studies to examine the impact of various urban designs on urban microclimate and outdoor thermal comfort. This method aims to develop future climate-sensitive urban designs (Montazeri et al., 2017).

- **Period of study:** the predominant focus of the selected studies has been on summer. Despite Cfb cities not experiencing severe climatic issues, it is essential to extend considerations to winter conditions. Exploring the impact of local climate warming during winter and assessing potential benefits, such as reduced heating energy requirements, becomes crucial. Additionally, investigating the potential Urban Heat Island (UHI) effect resulting from this warming is necessary. Future studies in this direction will significantly contribute to the design strategy of these cities.

The research gaps identified in this study should be considered when developing a comprehensive guideline for Cfb cities in future research. Furthermore, architects and urban designers can take these factors into account when creating new designs for Cfb cities, with the aim of enhancing outdoor thermal conditions and mitigating the effects of urban design on the Urban Heat Island (UHI) and, where applicable, addressing the impacts of climate change.

3.6 Conclusion

Despite numerous warnings from previous researchers regarding the Urban Heat Island (UHI) effect and climate change in Cfb cities worldwide, these concerns have been neglected in the realm of microclimatic studies and outdoor thermal comfort. In this literature review, our aim is to identify the actions taken to analyse microclimatic conditions in Cfb cities.

The results reveal that, despite there being more than 50 Cfb cities worldwide, the number of

microclimatic publications meeting our criteria is less than 45, with only 17 Cfb cities represented. The average number of publications for each Cfb city is fewer than 3 papers. In conclusion, there are evident research gaps, and developing a comprehensive guideline is deemed impossible at this stage.

However, based on the analysis of the selected papers, these findings are recommended for future researchers in Cfb cities:

- Increasing greenery, especially trees, to reduce air temperature and wind speed.
- The impacts of trees on reducing air temperature are significantly more important than green roofs and walls due to the evapotranspiration and shading effects.
- Examining the impacts of façade greenery on mean radiant temperature.
- Using wider-crowned trees or placing trees closer to the edge of buildings to mitigate wind speed.
- Utilizing lightweight materials to decrease thermal stress.
- Investigating the impacts of cooling materials on decreasing land surface and mean air temperature.
- High albedo materials mean increasing reflections and more solar radiation.
- Using building materials with high albedos to reduce surface temperature.
- Increasing high albedo material for walls in wide canyons with more road reflectivity.
- For a cooling strategy, using a higher roof albedo and improving greenery.
- Implementing a flexible canopy to decrease solar radiation in summer and permit sunlight in winter.
- Decreasing thermal stress and air temperature by increasing aspect ratio.
- Reducing solar radiation by high-rise buildings.

- E-W orientations have the worst thermal comfort level, improving shading in these orientations with buildings and trees.
- Using self-shading façades to improve thermal comfort.
- Increasing the aspect ratio on NE-SW orientations for decreasing sun radiation.
- Increasing ventilation and achieving lower local air temperatures through openings between buildings or the presence of high-rise buildings in a lower building area.

Chapter 4 A systematic review of microclimate and outdoor thermal comfort studies in Australia and New Zealand

4.1 Prelude

Chapters 2 and 3 delved into the criteria for selecting locations and the existing microclimate and outdoor thermal comfort studies in Climate for Building (Cfb) cities, offering valuable insights for choosing a location in Auckland while considering previous gaps and recommendations. However, for a more comprehensive understanding beyond Auckland, encompassing the entirety of New Zealand and Australia, Chapter 4 sought to provide insight into past microclimate and outdoor thermal comfort studies in these regions. The study's findings reveal limited investigation despite the diverse climate challenges in New Zealand and Australia. Melbourne emerges as a focal point in past research, particularly in studying people's thermal perceptions in residential areas during summer through field measurements and surveys. A significant gap identified is the lack of exploration into the impacts of various urban contexts on microclimatic conditions using software simulations over a year, considering the anticipated future climate changes in these countries. Addressing these gaps is imperative for future researchers in the region.

4.2 Introduction

Intuitively, people understand the benefits of being outdoors to their physical and mental wellbeing (Russell et al., 2013). With the development of urbanization (Zhang, 2016), the unprecedented growth of the urban population (Wan & Wang, 2014), the trend of high temperatures and heatwaves (Tan et al., 2010), and the Urban Heat Island (UHI) effect (Mirzaei, 2015), urban dwellers' lifestyles have become more sedentary (Varo et al., 2003). Moreover, indoor multifunctional buildings have been built in cities to meet residents' various daily requirements- (Todorović, 2012), which, in turn, leads to the reduction of urban outdoor

spaces (Lai et al., 2019). These trends challenge urban designers in expanding their understanding of outdoor thermal comfort and improving the thermal environment of outdoor urban spaces (Elnabawi & Hamza, 2019), to encourage citizens to spend more time outdoors to enhance individual health and wellbeing (Douglas et al., 2017).

Creating a comfortable urban environment is conducive to the increased use of open spaces and it promotes urban liveability (Nieuwenhuijsen, 2021). Although a comfortable thermal environment can enhance people's choices to attend outdoors (Lin, 2009), heat stress can cause significant discomfort (Epstein & Moran, 2006), altering the frequencies and patterns of outdoor activities (Chen & Ng, 2012). Surrounding environmental parameters (e.g. ambient air temperature, humidity, radiation and wind velocity) and personal variables (e.g. clothing insulation and metabolic rate) are essential for developing thermal comfort models (Fang et al., 2021). To help urban communities improve the quality and comfort levels of outdoor and indoor environments, the following strategies have been considered by previous researchers: advanced materials (e.g. highly reflective, fluorescent surface and thermochromics material) (Mohammad et al., 2021), green infrastructure (Wang et al., 2022), changes in urban geometry (Lai et al., 2019), solar control systems (Dounis & Caraiscos, 2009) and advanced water and evaporative systems (Santamouris et al., 2017).

The outdoor thermal comfort requirements of the same outdoor space likely differ amongst users from different climatic backgrounds (Lam et al., 2021). Furthermore, there has been worldwide interest in studying how outdoor thermal comfort differs in various climates (Höppe, 2002). Moreover, people from different climatic backgrounds express differences in thermal sensation and clothing choices (behavioural adaptations) (Jiao et al., 2017). Therefore, predicting and evaluating outdoor thermal comfort is of great importance for encouraging residents to enjoy their daily lives in urban outdoor areas in various climates (Niu et al., 2015).

It may also provide guidance to city designers for better local urban designs (Fong et al., 2019).

This paper addresses the limited number of microclimate and outdoor thermal comfort studies in Australia and New Zealand, emphasizing the uniqueness of their climates compared to other regions. The need for country-specific research is highlighted to ensure the relevance and accuracy of findings. The paper aims to review existing studies in these countries to establish a baseline for future research, identify gaps, and pinpoint areas requiring further investigation. The study's objectives include identifying relevant studies, categorizing them by cities and climate types, analysing methodologies, study durations, and investigated factors, as well as assessing achievements and identifying gaps in this research field. The ultimate goal is to provide recommendations for future studies, focusing on neglected yet crucial aspects of microclimate and outdoor thermal comfort in Australia and New Zealand.

4.3 Climate of Australia and New Zealand

Australia's climate is diverse due to its vast size. The majority of the country consists of desert or semi-arid regions, while the southeast and southwest corners have temperate climates with fertile soil. The northern part experiences a tropical climate, ranging from grasslands to deserts. Australia holds various heat-related records (Crosbie et al., 2012). The Köppen climate classification map of Australia is illustrated in Figure 4.1. The climate varies significantly across cities. For instance, daily temperatures can range from 5.7°C in New South Wales to 30.8°C in Queensland during summer (Lucas et al., 2005). Different regions experience unique weather patterns, such as frequent thunderstorms and rain in Perth, cold fronts in the south coast of Western Australia, and Melbourne's reputation for experiencing all four seasons in one day. Sydney enjoys warm, mild weather, while Brisbane tends to be hotter and drier. The northern regions experience wet and dry seasons, with Darwin having a wet season characterized by high humidity, monsoonal rains, and storms from November to April. Cairns experiences heavy rainfall in the summer, with strong winds during autumn and winter.

Australia's diverse climate poses various challenges in different regions (White et al., 2013).

New Zealand's climate is diverse, influenced by its varied landscape. Most regions fall under a temperate oceanic climate (Köppen classification Cfb), characterized by four distinct seasons. Winters are mild, and summers are relatively cool. The Pacific Ocean and latitude are major factors in this climate, though nearby mountains can lead to significant variations in climate within short distances. Conditions range from extremely wet on the West Coast of the South Island to semi-arid in central Otago and subtropical in Northland (MacLeod & Korycinska, 2019). The Köppen climate classification map of New Zealand is illustrated in Figure 4.2. The Cfb classification results in generally mild temperatures with few extremes. While temperatures exceeding 30°C are infrequent, weather conditions can change rapidly due to New Zealand's narrow geography (McGlone, 2002). The country experiences strong sunlight and relatively high, evenly distributed rainfall, particularly in warmer months (Kidston et al., 2009). New Zealand is positioned in the latitudes of prevailing westerlies, leading to strong coastal winds in exposed areas. Wellington averages a significant number of windy days with gusts exceeding 60 km/h, in contrast to other cities like Rotorua, Timaru, and Nelson, which experience lighter winds (Bolton et al., 2022).

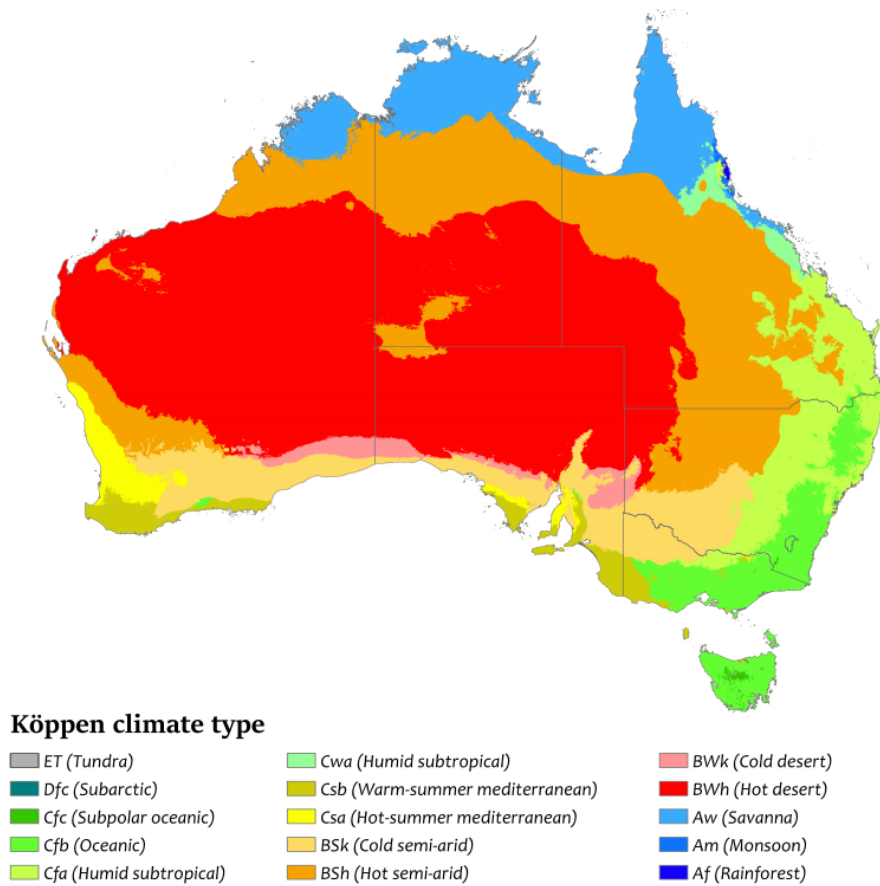

Figure 4.1 Köppen climate classification map of Australia (Peel et al., 2007)

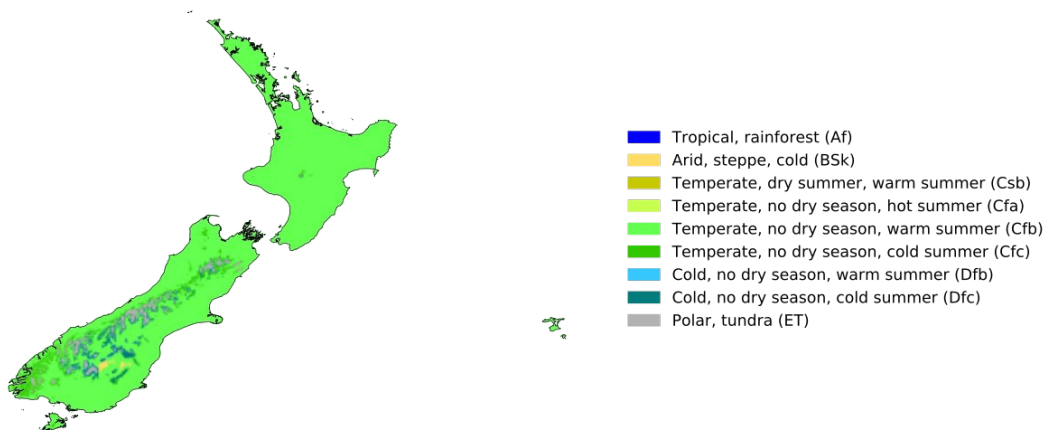

Figure 4.2 Köppen climate classification map of New Zealand (Peel et al., 2007)

4.3.1 Research significance

The diverse weather challenges across different cities in New Zealand and Australia, coupled with the population growth pressure, as indicated in Figure 4.3 and Figure 4.4, underscore the critical need for the analysis of outdoor thermal comfort in both countries, as detailed in Table

4.1. This review has highlighted the existing gaps in research related to urban microclimate and outdoor thermal comfort in Australia and New Zealand, setting the foundation for future research to address these essential yet often overlooked aspects of urban microclimate.

The findings of this paper serve to enhance the understanding of the impact of urban microclimate for urban planners and those responsible for developing climate change policies in Australia and New Zealand. Recognizing the significance of urban microclimate in strategies for people's adaptation to and mitigation of various environmental factors, as well as in the future development of urban areas in these countries, is strongly emphasized. This research contributes to the broader conversation on climate change adaptation and urban development in the region.

Table 4.1 Population growth and climate change in Australia and New Zealand

Australia	New Zealand
<p>Population growth (Swan, 2010):</p> <ul style="list-style-type: none"> Australia's population forecast for 2022 is 25,768,000 and is forecasted to grow to 31,433,000 by 2041. Over the next 40 years, the rate of population growth is expected to slow to 1.2% on average per annum. On the basis of these trends, Australia's population is projected to reach 35.9 million in 2050 (Figure 3). 	<p>Population growth (Chilibeck et al., 2022):</p> <ul style="list-style-type: none"> New Zealand's population (5.13 million in 2022) has a 90% probability of increasing to between 5.17 and 5.55 million in 2028 and to between 5.28 and 5.85 million in 2033 (Figure 4).
<p>Population density (Yigitcanlar et al., 2022) :(Population density is midyear population divided by land area in square kilometers (sq. km))</p>	<p>Population density (Summers et al., 2020) :(Population density is midyear population divided by land area in square kilometers (sq. km))</p>

- Australia’s population density in June 2021 was 3.3 people per sq.km. The most densely populated areas were Melbourne CBD North, Southbank East in inner Melbourne, and Sydney (South) Haymarket in inner Sydney (Figure 3).
- Population density in New Zealand was reported at 19.45 sq. km in 2020. Territorial authorities with the highest population densities include Hamilton City, Tauranga City, Wellington City, Napier City, Porirua City and Auckland City (Figure 4).

Predicted climate change (Short, 2022):

- Hot days will become more frequent and hotter (very high confidence).
- Sea levels will rise (very high confidence).
- Extreme rainfall events will become more intense (high confidence).
- Seasonal-average rainfall changes will vary across Australia.
- There exists high confidence in increasing potential evapotranspiration (atmospheric moisture demand).
- Southern and eastern Australia is projected to experience harsher fire weather (high confidence).
- Projected changes will be superimposed on significant natural climate variability.

Predicted climate change (Broekhuizen et al., 2021):

- Temperature change is for an expected increase of about 0.8 °C by 2040, 1.4 °C by 2090, and 1.6 °C by 2110.
- The possible projections for future warming span a wide range: 0.2 °C –1.7 °C by 2040, 0.1 °C –4.6 °C by 2090, and 0.3 °C –5.0 °C by 2110.
- Projected changes in rainfall show a marked seasonality and variability across regions. An increase in rainfall for the west of North and South Island
- For summer, wetter conditions are more likely to occur in the east of both islands, with drier conditions in the west and central North Island.

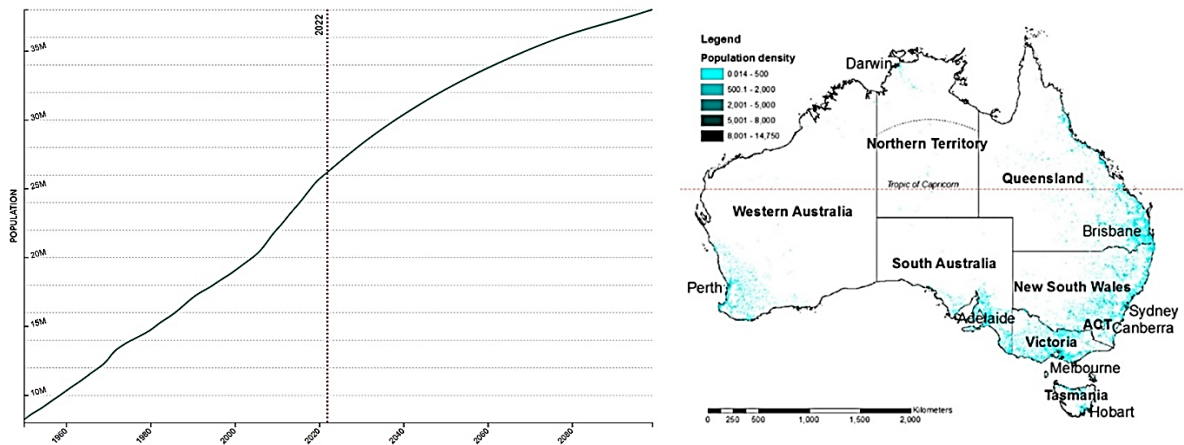

Figure 4.3 Population growth and density of Australia (Cameron et al., 2019)

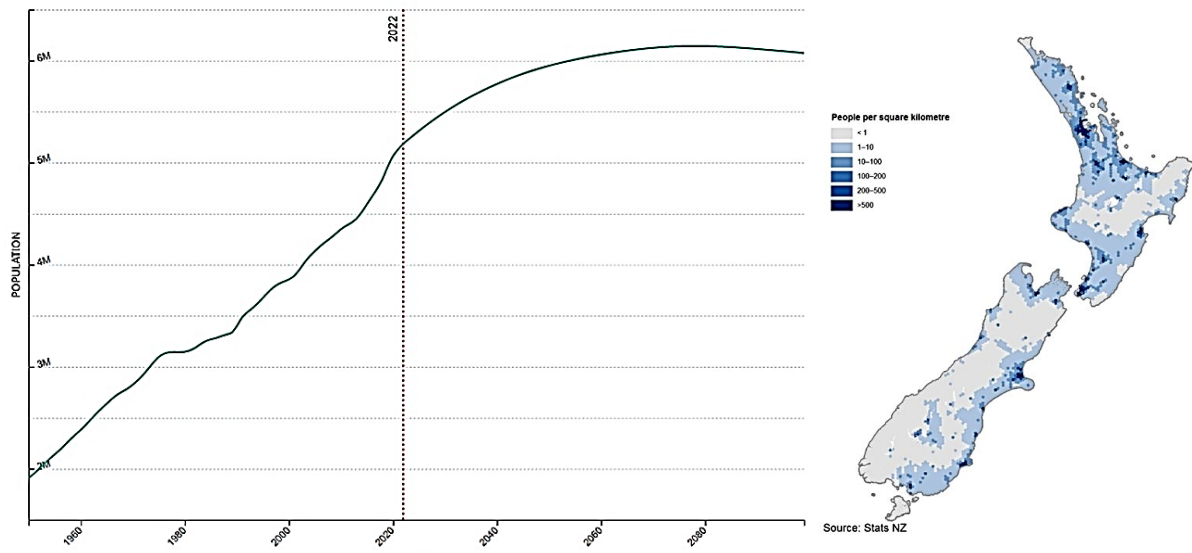

Figure 4.4 Population growth and density of New Zealand (Source: Stats NZ)

4.4 Methodology

The selection of a database is crucial for conducting scientific reviews due to its direct influence on the reliability of findings (Pham, 2020). Dimensions database is a cutting-edge, innovative, and linked research data infrastructure and platform that re-imagines discovery and access to research (Ittmann, 2021). It provides access to over 106 million publications and has over 1.2 billion cited references across many disciplines. Given its scientific integrity and completeness, the Dimensions database was selected in this paper for the extraction of publication items.

To begin, a search syntax was created to include phrases associated with the concept of

'Microclimatic studies' and 'Outdoor thermal comfort' since the beginning of these research types (from 1985 to 2022). To do so, a search string was created using terms such as 'Microclimate', 'Microclimatic conditions', 'Microclimatic studies', 'Microclimatic research' AND 'Outdoor thermal comfort', 'Outdoor thermal discomfort', 'Outdoor thermal preference', 'Outdoor thermal sensation', 'Outdoor thermal satisfaction' and 'Outdoor thermal preference'. These keywords were then combined with "the Australian or New Zealand cities" using Boolean operators ('AND') to create a search query which was used to access the Dimensions database and acquire essential data. To eliminate papers unrelated to the goals of this study, various filters were applied. Firstly, only articles were included in the search because of their thoroughness and reputation as 'certified knowledge' (Wuni et al., 2019). Secondly, publications written in non-English languages were excluded. Thirdly, resources unrelated to building and environment were excluded. The database search was conducted between October and December 2022, using the keywords from the logic grid in titles, keyword lists and abstracts of publications. As a result, 32 documents met the initial criteria. To ensure that no research-worthy content was missed, similar keywords were searched on additional scholarly platforms, such as Science Direct, Web of Science, and Google Scholar (in case it would not be indexed by Dimensions). If no duplicates were present, the detected resources were compared with the preliminary database and considered for inclusion. The preliminary database was expanded by seven more articles. This process also involved a second search through the selected publications' reference lists to identify related papers that had not appeared in the first database search. Resulting in four additional papers for full-text screening. As a result, the total number of identified items was 42 (Figure 4.5).

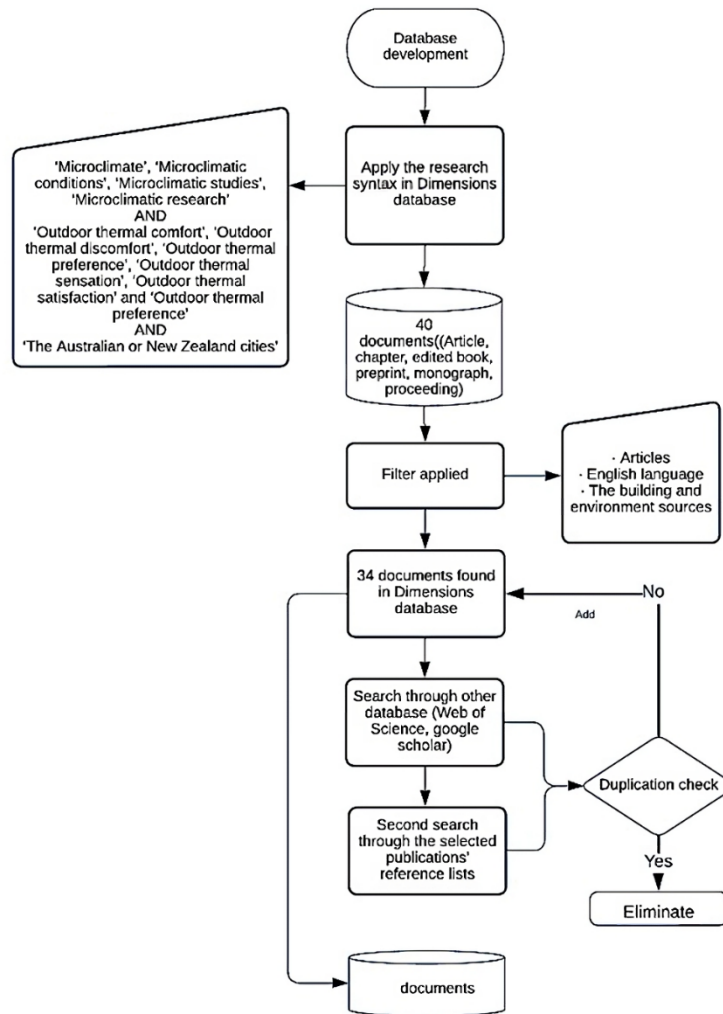

Figure 4.5 Methodological process

From the 42 selected papers, 36 studies examined Australia across 5 cities (i.e. Melbourne, Sydney, Adelaide, Geelong, and Darwin, and 6 studies investigated New Zealand across 3 major cities (i.e. Christchurch, Wellington, and Auckland). Figure 4.6 demonstrates the trend of microclimate and outdoor thermal comfort studies in Australia and New Zealand from 1980 to 2022. Figure 4.6 displays the number of papers in both countries from 1980 to 2022.

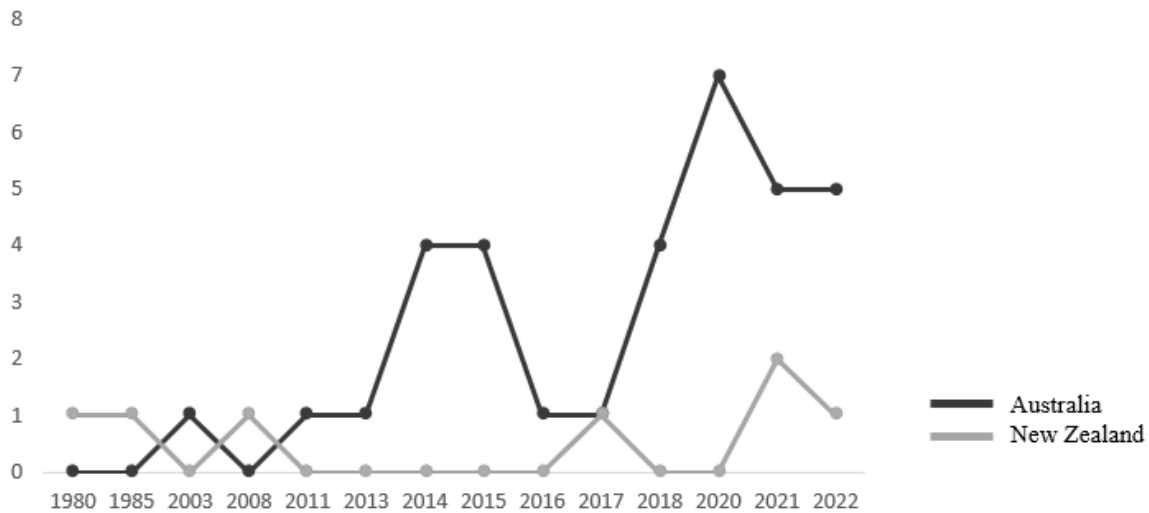

Figure 4.6 Number of selected papers in different years for Australia and New Zealand

4.5 Analysing existing papers in Australia and New Zealand

Based on our criteria, a total of 36 papers for analysing microclimate and outdoor thermal comfort were found in Australia since 1985. Melbourne has the highest number of microclimate and outdoor thermal comfort studies amongst different cities in Australia, followed by Sydney and Adelaide (Table 4.2).

Table 4.2 Previous microclimate and outdoor thermal comfort papers in Australian cities

City	Type of climate	Number of papers
Melbourne	Temperate oceanic climate (Cfb)	19
Sydney	Humid subtropical climate (Cfa)	10
Adelaide	Mediterranean climate (Csb)	3
Geelong	Temperate oceanic climate (Cfb)	1
Darwin	Tropical savanna climate (Aw)	1

4.5.1 Melbourne

Melbourne experiences a temperate oceanic (Cfb) climate with an average annual temperature of 14.4 °C. The warmest month is January, with an average temperature of 20 °C, while the coolest month is July, averaging 8.9 °C. Despite its generally mild climate, Melbourne is prone

to temperature fluctuations due to the influence of cold air masses from the surrounding Antarctic Sea and hot, dry air masses from the Australian desert. The city also experiences frequent winds, and rainfall levels are relatively modest (Harmay et al., 2021). Based on the criteria, a total of 19 microclimatic papers were found for Melbourne climate, as shown in Table 4.3.

Table 4.3 Previous microclimate and outdoor thermal comfort studies in Melbourne, Australia

	Year	Location	Method of study	Period of study	Investigated factors	Findings
Melbourne (Cheung et al., 2022)	2022	Backyard	Field measurement	Summer	Greenery impacts on outdoor thermal comfort	Turf irrigation has the potential to significantly improve the thermal conditions of backyards in combination with the use of tree shade.
Melbourne (Balany et al., 2022)	2022	Residential area	Field measurement and software simulation	Summer	Effects of greenery and blue infrastructure on microclimate	The impact of trees on reducing air temperature is significantly more important than green roofs and walls. the effect of water is only being felt up to a certain distance away from the fountain.
Melbourne (Falasca et al., 2022)	2022	Residential areas	Field measurement and software simulation	Summer	Effects of cool materials on climate	The effectiveness of the high-albedo materials in an urbanisation class is influenced by the land use of the adjacent cells.
Melbourne (Meili et al., 2021)	2021	Urban street	Field measurement	Summer	Cooling potential of urban trees	Evapotranspiration of well-watered trees alone can locally decrease 2 m of air temperature at maximum by 3.1 °C – 5.8 °C during summer.
Melbourne (Rajagopalan et al., 2020)	2020	Residential area	Field measurement and software simulation	Summer	People’s outdoor thermal perceptions	The results show that the outdoor Universal thermal climate index (UTCI) values estimated during hot afternoon ranged from 26 °C to 46 °C which equate to moderate to extreme heat stress.
Melbourne (Ng et al., 2020)	2020	Residential area	Field measurement and software simulation	Summer	Effects of greenery and geometry on microclimate	Green areas have low temperatures in all hours compared with high-rise areas.
Melbourne (Motazedian et al., 2020)	2020	Urban Park	Field measurement	Summer	Influence of greenery on microclimate	Influence of sky view factor and distribution of vegetation on cooling in nights.
Melbourne (Lam et al., 2021)	2018	Melbourne Garden	Field surveys	Summer	People’s outdoor thermal perceptions	Peoples’ thermal sensations depended on a significant interaction amongst UTCI thermal stress levels, climate zones, and prior exposure environment.
Melbourne (Kenawy & Elkadi, 2018)	2018	University	Field measurements and field surveys and	Summer and winter	People’s outdoor thermal perceptions	The results endorse the significant effects of thermal adaptation

			software simulation			factors on users' comfort levels and acceptability for micrometeorological environments.
Melbourne (Jamei & Rajagopalan, 2019)	2018	Residential and commercial areas	Field measurement and software simulation	Summer	Effects of geometry and greenery on microclimate	The aspect ratio was increased to decrease air temperature. East-west (E-W) orientations have the worst thermal comfort level, improving shading in these orientations with buildings and trees.
Melbourne (Sharifi & Boland, 2018)	2018	Residential area	Field measurement and software simulation	Summer	Human thermal perceptions	The crucial zero-activity threshold of 48 °C may be extended by space designs, regional climatic assumptions and flexible activity choices.
Melbourne (Shooshtarian & Ridley, 2017)	2017	University	Field measurements and field surveys	Spring and summer	People's outdoor thermal perceptions	Medium and low influences of physical and psychological factors on outdoor thermal sensations, respectively.
Melbourne (Shooshtarian & Ridley, 2016)	2016	University campus	Field measurement and field surveys	Summer	Human thermal perceptions	Significant influence of a few human-dependent variables on outdoor thermal perceptions
Melbourne (Shooshtarian et al., 2015)	2015	Residential areas	Field measurement and field surveys	Summer and spring	Human thermal perceptions	Moderately to slightly comfortable conditions in the spring to just right to slightly uncomfortable conditions in the summer
Melbourne (Sanusi et al., 2016)	2015	Urban street	Field measurement	Summer	Influence of greenery on outdoor thermal comfort	In streets with high-percentage canopy cover, air temperature, relative humidity, solar radiation, and mean radiant temperature were significantly lower than in streets with low-percentage canopy cover.
Melbourne (Shooshtarian & Rajagopalan, 2019)	2015	University	Field measurements and field surveys	Spring and summer and autumn	Effect of wind speed on outdoor thermal comfort	Wind perceptual comfort thresholds for different seasons as well as the entire study period.
Melbourne (Shooshtarian & Ridley, 2016)	2014	University	Field measurements and field surveys	Spring and summer and autumn	Acceptable thermal range in outdoor built environments	Various elements of thermal perceptions expressed the users' thermal judgements in different ways.

Melbourne (Lam & Lau, 2018)	2014	Residential area	Field measurements and field surveys	Summer	People's outdoor thermal perceptions	Melbourne residents reported warm and hot sensation at a higher UTCI range than the DTS model. The respondents in Melbourne also exhibited different responses to the mean radiant temperature under shaded and sunny conditions
Melbourne (Coutts et al., 2016)	2013	Urban street	Field measurement	Summer	Influence of greenery on outdoor thermal comfort	Trees should be strategically placed to maximise their shade area yet spaced sufficiently to allow some nocturnal longwave cooling and ventilation

Table 4.3 illustrates the importance of analysing outdoor thermal comfort in microclimate studies within Melbourne. Previous research has utilized various outdoor thermal comfort indices and field measurements to address the Urban Heat Island (UHI) phenomenon and alleviate heat stress in urban areas. The threshold for essential zero-activity was found to be 48 °C, with summer and spring being perceived as warm in terms of outdoor thermal comfort, particularly summer. Melbourne residents' thermal sensation is more sensitive to changes in air temperature than to short and longwave radiation. Increased green infrastructure, particularly tree-based scenarios, has been shown to enhance outdoor thermal comfort by reducing heat stress through evaporation and shading, while the effects of green roofs and walls are minimal.

Researchers have recognized that air temperature decreases as the aspect ratio of urban features increases. East-West (E_W) street orientations tend to have the worst outdoor thermal comfort in Melbourne. Water features have specific effects on outdoor thermal comfort up to a certain distance. The cooling benefits of street tree canopies increase as street canyon geometry becomes shallower and wider.

The existing studies in Melbourne have primarily focused on outdoor thermal comfort during summer, especially in residential areas, using field measurements and surveys. To enhance

result accuracy, there is a need to analyse microclimatic conditions and outdoor thermal comfort throughout the winter season using various software simulations, addressing a notable gap in previous research. While earlier studies have considered the effects of greenery, less emphasis has been placed on the impacts of urban geometry, especially aspect ratio and materials.

4.5.2 Sydney

Sydney experiences a humid subtropical climate, classified as Cfa according to the Köppen climate classification. The city has an average annual temperature of 17.8 °C. February is the warmest month, with an average temperature of 22.8 °C, while July is the coolest month, averaging 11.7 °C. Sydney receives significant rainfall throughout the year, including during the driest months. This climate description indicates mild winters and warm summers with a relatively consistent distribution of precipitation (Santamouris et al., 2018). Based on our criteria, a total of 10 microclimatic papers were found for Melbourne climate as shown in Table 4.4.

Table 4.4 Previous microclimate and outdoor thermal comfort studies in Sydney, Australia

	Year	Location	Method of study	Period of study	Investigated factors	Findings
Sydney (Heshmat Mohajer et al., 2022)	2022	Residential area	Field measurements and software simulation	Summer	Effects of greenery and materials on microclimate	Scenarios that increase high-albedo material on the road, pavements and rooftops and full mitigation show the maximum cooling potential.
Sydney (Abdollahzadeh & Bioria, 2022)	2022	Residential area	Field measurements and software simulation	Summer	Effects of geometry and materials and greenery on microclimate	High-rise slab buildings exposed to N_S streets by their longer edge with high glazing facade provide the highest level

						of thermal comfort in urban environments.
Sydney (Fleck et al., 2022)	2022	Residential area	Field measurements	One-year period	Effects of green roofs on outdoor thermal comfort	Green roofs may contribute to the essential reduction in ambient city temperature to alleviate overheating and the costs associated with the UHI effect.
Sydney (Sadeghi et al., 2022)	2022	Residential areas and urban streets	Field measurements and software simulation	Summer	Benefits of urban heat mitigation technologies on human heat balance and population mortality	Urban greening infrastructure scenarios reduce the daily average UTCI between 0.2 °C and 1.7 °C during a heatwave, with the health impact assessment indicating heat attributable deaths reducing up to 11.7 per day across Sydney.
Sydney (Liu et al., 2021)	2021	Urban street	Field surveys	Summer and winter	People's outdoor thermal perceptions	The study yielded the preferred thermal sensation at 41/100 in summer and 64/100 (0: cold, 50: neutral, 100: hot) in winter, indicating that the subjects preferred cooler than neutral (thermal sensation =50) in summer while warmer than neutral in winter.
Sydney (Bartasaghi-Koc et al., 2021)	2021	Urban street	Field measurements and software simulation	Summer	Effects of geometry and materials and greenery on microclimate	Combining reflective materials, increased greenery, spray systems, and traditional shading provides a highly significant reduction of ambient (Ta) and surface (Ts) temperatures.

Sydney (Zou et al., 2021)	2021	University and urban Park	Field measurements and software simulation	Autumn and winter	People's outdoor thermal perceptions	The results of this study demonstrated the significance of capturing the turbulent wind conditions for accurately predicting heat loss for outdoor thermal comfort studies.
Sydney (Abdollahzadeh & Bioria, 2021)	2021	Urban street	Field measurements and software simulation	One-year period	Effects of urban configurations on thermal performance	Street canyon orientation is the most influential factor (46.42%), followed by aspect ratio (30.59%).
Sydney (He et al., 2020)	2020	Residential area	Field measurements and software simulation	Spring and summer and autumn	Precinct ventilation performance on outdoor thermal comfort	When the sea breeze prevailed, wind exhibited its cooling potential under the combination of negative UHII and shading as well as that of positive UHII and solar exposure.
Sydney (Spagnolo & De Dear, 2003)	2003	Not mentioned	Field measurements	Summer and winter	People's outdoor thermal perceptions	The thermal neutrality in terms of the thermal comfort index OUT SET* of 26, 2 °C was significantly higher than the indoor SET* counterpart of 24 °C.

Table 4.4 highlights the significance of analysing the effects of geometry, materials, and greenery in microclimatic studies in Sydney. Optimizing design parameters with a focus on these factors can enhance thermal comfort and create pleasant outdoor living environments. Prior research in Sydney has thoroughly examined microclimatic conditions during both summer and winter using a combination of field measurements and software simulations.

Strategies to increase the albedo of streets and pavements show promise in reducing peak

ambient temperatures in Sydney, while various cooling technologies have the potential to mitigate urban warming and enhance human thermal comfort by lowering air and surface temperatures. In the Sydney context, air velocity positively impacts the cooling potential of reflective and radiative cooling materials, shading, and greenery. However, it has a detrimental effect on spray water systems due to the rapid dispersion of water particles.

Notably, low-rise slab buildings exposed to East-West streets with shorter edges and fewer glazed facades offer the lowest energy usage, whereas high-rise slab buildings exposed to North-South streets with longer edges and extensive glazing facades provide the highest level of thermal comfort in urban environments. Additionally, green roofs in Sydney have shown potential to reduce building heating during the summer and severe heatwave conditions.

The gap in previous Sydney studies lies in the limited use of field surveys in research methodologies. Incorporating field surveys can improve result accuracy by comparing people's actual outdoor thermal comfort experiences with the outcomes of software simulations.

4.5.3 Adelaide, Geelong and Darwin

Adelaide has a Mediterranean climate (Köppen climate classification: Csb). The average annual temperature in Adelaide is 16.1 °C. The warmest month, on average, is January, with an average temperature of 21.7 °C. The coolest month on average, is July, with an average temperature of 11.1 °C. It is windy and mostly clear year-round (Sharifi et al., 2020). Based on the criteria, three microclimatic papers were found for Adelaide climate, as shown in Table 4.5.

Geelong has a Cfb climate. The average annual temperature in Geelong is 13.9 °C. The warmest month, on average, is January, with an average temperature of 18.9 °C. The coolest month, on average, is July, with an average temperature of 8.9 °C. Geelong is a city with a significant rainfall. It rains considerably even in the driest month (Roos et al., 2020). Based on the criteria, only one microclimatic paper was found for Geelong climate, as shown in Table

4.5.

Darwin has a tropical savanna climate (Köppen climate classification: Aw). The average annual temperature in Darwin is 27.8 °C. The warmest month, on average, is November, with an average temperature of 29.4 °C. The coolest month, on average, is July, with an average temperature of 25 °C. The summers are considerably rainier than the winters in Darwin (De Vet, 2017). Based on our criteria, only one microclimatic paper was found for Darwin climate as shown in Table 4.5.

Table 4.5 Previous microclimate and outdoor thermal comfort studies in Adelaide and Geelong, Australia

	Year	Location	Method of study	Period of study	Investigated factors	Findings
Adelaide (Sharifi et al., 2020)	2020	Urban street	Software simulation	One-year period	Influence on greenery on surface temperature	The results indicated that an ideal urban landscape transformation scenario with 30% tree canopy can effectively decrease the surface temperature by 1 °C in winter and 3 °C in summer by 2090. It is estimated that having greener and more heat resilient public spaces can save the total carbon emission.
Adelaide (Sharifi et al., 2016)	2015	Plaza and square and mall	Field measurements and site observations	Summer	People's outdoor thermal perceptions	Necessary and optional activities start to decline after the apparent temperature reaches the threshold of 28 °C -32 °C , whereas activities in public spaces with more

						urban greenery show higher resilience to heat stress.
Adelaide (Sharifi et al., 2017)	2014	Urban street	Field surveys	Summer and autumn	People's outdoor thermal perceptions	Outdoor activity choices are affected significantly by the urban microclimate parameter of solar radiation, including tree canopy, shading (from buildings or temporary elements) and water features.
Darwin (Yenneti et al., 2020)	2020	Residential area	Field measurements and software simulation	One-year period	Impacts of thermal risks on residents	The best-performing mitigation scenario, which combines cool materials, shading, and greenery, reduces the peak ambient temperature by 2.7 °C.
Geelong (Kenawy & ElKadi, 2011)	2011	Urban street	Field measurements and field surveys	Summer	People's outdoor thermal perceptions	Differences in cultural diversity influence the perception of thermal comfort.
Sydney, Melbourne, Adelaide, and Geelong (Shooshtarian et al., 2020)	2020	Different urban contexts	Literature review	Long study period	Outdoor thermal comfort assessment	A local standard for assessing thermal comfort must be developed. Because adopting universal standards limits the effects of contextual factors and thermal adaptation on outdoor thermal comfort perception.
Sydney, Melbourne and Adelaide (Sharifi & Boland, 2018)	2014	Public spaces	Field measurements and field observations	Summer and autumn	People's outdoor thermal perceptions	Before the outdoor thermal environment of UTCI = 22 °C –34 °C, no significant decline was observed in outdoor living, and people adapted their outdoor activities, clothing, and activity rate

to achieve thermal
comfort.

In Table 4.5, it is evident that tree canopies are highly appealing public space features during heat stress conditions in Adelaide. Shading, soft landscapes, and water features are also preferred in hot microclimates. The presence of urban greenery and ample shading facilitates more diverse and extended activities in public spaces, especially during high temperatures. Increasing the number of tree canopies, soft landscapes, and shadow coverage is recommended to enhance spatial heat resilience (SHR) in public spaces. More greenery contributes to improved thermal comfort, resulting in increased resilience to heat stress and a reduction in thermal load on outdoor participants. This, in turn, fosters a more vibrant and healthier public life in cities.

The importance of cultural diversity as a variable in determining subjective thermal comfort was emphasized in Geelong. Urban planners should consider the comfort of individuals from diverse cultural backgrounds rather than relying solely on measured Predicted Mean Vote (PMV) values. Results showed that different cultural groups perceive overall comfort differently from the comfort calculated from actual measurements.

A comprehensive analysis of the urban microclimate was conducted in Darwin, Australia, assessing the effects of heat mitigation technologies in reducing ambient temperatures. Their study quantified the benefits of city-scale heat mitigation on human health, energy consumption, and peak electricity demand. The proposed heat mitigation approach demonstrated the potential to save lives by reducing excess deaths in the Darwin urban health district.

However, due to the limited number of studies in Adelaide, Darwin, and Geelong, it is currently impossible to draw conclusive findings for these cities. Future research in these areas should

address the mitigation of wind speed impacts through urban design in Adelaide and rainfall-related issues in Darwin and Geelong, considering the unique climate characteristics of each city.

4.5.4 Results of microclimatic and outdoor thermal comfort studies in Australia

In Figure 4.7 Results of microclimate and outdoor thermal comfort studies in Australia, the analysis of papers indicates that the majority of earlier publications in Australia, specifically 20 out of 36, have focused on regions with a Cfb climate. Additionally, based on the publication years, there is a growing trend in research, with 19 out of the 36 publications published since 2020 showing an increasing interest in the analysis of microclimate and outdoor thermal comfort. Previous research has primarily fallen into three main categories: people's perceptions of outdoor thermal comfort, the impact of urban contexts and greenery on outdoor thermal comfort, and the effects of urban contexts and greenery on meteorological data, specifically microclimate conditions.

A significant portion of this research, nearly half, has concentrated on people's outdoor thermal perceptions, utilizing field measurements and surveys during the summer, particularly in residential areas. This highlights a growing interest in understanding how individuals perceive and experience outdoor thermal comfort in various urban environments.

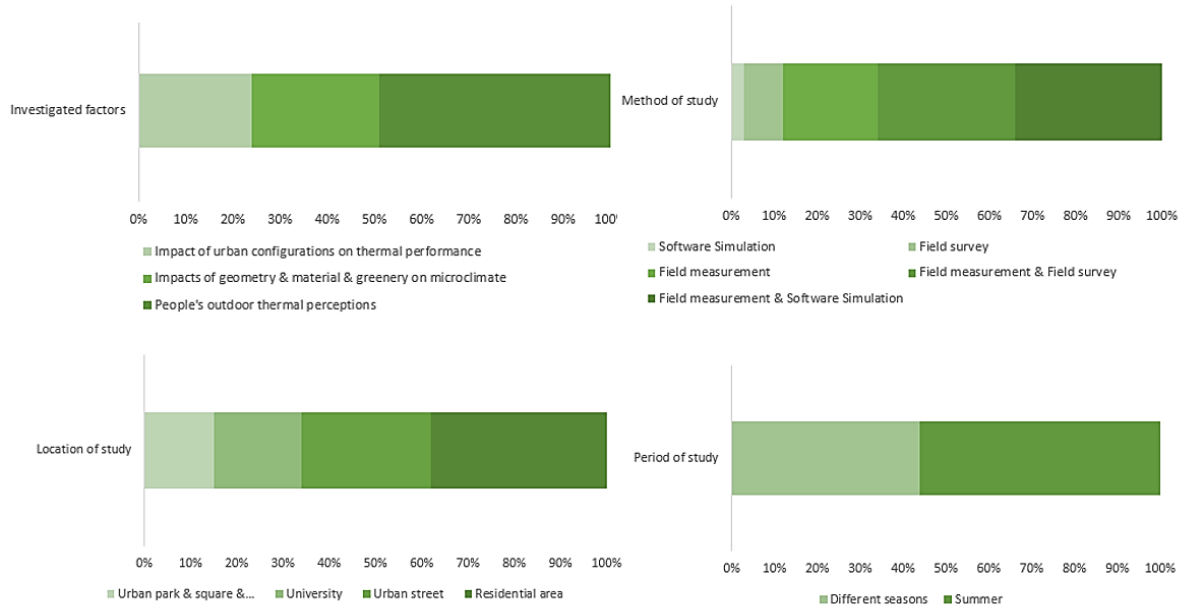

Figure 4.7 Results of microclimate and outdoor thermal comfort studies in Australia

4.5.5 New Zealand (Christchurch, Auckland, Wellington)

Based on our criteria, the number of microclimate and outdoor thermal comfort analysis in different cities of New Zealand is limited. Only six papers were conducted in cities of Christchurch, Wellington and Auckland. In the following, the studies based on different cities were analysed in more detail (Table 4.6).

Table 4.6 Previous microclimate and outdoor thermal comfort papers in New Zealand cities

City	Type of climate	Number of papers
Christchurch	Temperate oceanic climate (Cfb)	3
Auckland	Temperate oceanic climate (Cfb)	2
Wellington	Temperate oceanic climate (Cfb)	1

Christchurch

Christchurch has temperate oceanic (Cfb) climate. The average annual temperature in Christchurch is 11.6 °C. The warmest month, on average, is January, with an average temperature of 17.2 °C. The coolest month, on average, is July, with an average temperature of 5.8 °C. Christchurch is a city with a significant rainfall (Lorrey & Bostock, 2017). Based on

our criteria, three microclimatic papers were found for Christchurch climate as shown in Table 4.7.

Auckland

Auckland has temperate oceanic (Cfb) climate. The average annual temperature in Auckland is 15.5 °C. The warmest month, on average, is February, with an average temperature of 20.3 °C. The coolest month, on average, is July, with an average temperature of 10.9 °C. Auckland is windy and partly cloudy year-round, with significant rainfall throughout the year (Lorrey & Bostock, 2017). Based on our criteria, two microclimatic paper was found for Auckland climate as shown in Table 4.7.

Wellington

Wellington has Cfb climate. The average annual temperature in Wellington is 11.3 °C. The warmest month, on average, is February, with an average temperature of 15.9 °C. The coolest month, on average, is July, with an average temperature of 6.6 °C. Wellington is however known for its southerly winds in winter, which makes the temperature feel considerably colder (Lorrey & Bostock, 2017). Based on our criteria, only one microclimatic paper was found for Wellington climate as shown in Table 4.7.

Table 4.7 Previous microclimate and outdoor thermal comfort studies in New Zealand

	Year	Location	Method of study	Period of study	Investigated factors	Findings
Christchurch (Perera et al., 2020)	2021	Public Park	Field surveys and field measurements	Summer	Combined effects of sun, wind and temperature with the aspects of human adaptation	Standard physiological models cannot be directly applied to different climates to predict the comfort levels for various thermal expectations.
Christchurch (Tavares et al., 2019)	2017	Urban streets	Field surveys and field measurements and field observations	Summer and winter	Nature and social meanings of urban comfort	The specific aspects of Christchurch's urban culture influencing local urban comforts are related to its biophysical landscape (geographical location, outdoor values and recreational and gardening activities) and social landscape (Garden City as a way of living, urban lifestyle and liveability).
Christchurch (Tuller, 1980)	1980	CBD and light industrial commercial, residential and rural areas	Field measurements and field observations	Winter	Amount of clothing insulation required to balance the body heat budget equation of a standing person with no change in body heat storage	The oceans and hill slopes have an effect comparable to that of most of the urban area and require less clothing than do all land use zones except the urban CBD.
Auckland (Jalali et al., 2022)	2022	Different parts of New Zealand	Literature review	Long study period	Microclimate and outdoor thermal comfort research in New Zealand	Models that consider the continuous changes to urban microclimate were providing, considering the uncertainty of climate change effects on weather

						factors such as temperature and airflow.
Auckland (De Freitas et al., 1985)	1985	Urban streets	Field measurement and field observations	Summer	Heat stress assessment	The geometry effect of the group runner's environment on airflow around a tightly encircled individual within the group is different from that of a solo runner.
Wellington (Isaacs & Donn, 2021)	2021	Residential area	Field measurement and software simulation	Winter	Effects of site parameters on house heating energy	The ground surface material is the only parameter that significantly affects the outdoor air temperature, averaging a 1 °C increase and reducing house heating energy use by up to 11.6%.

In Christchurch, outdoor thermal comfort has been the subject of investigation during both winter and summer seasons using field measurements and site observations. Prior research has identified limitations in using physiological models to predict people's feelings and preferences in outdoor environments, emphasizing the need for model calibration to account for varying climates and local adaptations. Researchers have noted that a generic physiological model cannot fully capture the diversity of local adaptations as individuals adjust their cultural and lifestyle values and expectations to their specific microclimatic conditions. Air temperature and thermal radiation are identified as the key climatic elements directly influencing clothing requirements in urban and rural settings.

In Auckland, studies have explored the mean radiant temperature of surroundings, specifically for different groups of individuals such as runners. Results have indicated slight variations in the radiant heat load due to the presence of a group compared to a solo runner. Jalali et al. conducted a literature review on urban microclimate research in New Zealand, revealing

inconsistencies in research parameters and methodologies and a lack of validation in previous studies. Neglect of future urban development and urban morphology has limited the scientific understanding of changes in New Zealand's urban microclimate.

The research in Wellington suggests that the limited impact of parameters, except air temperature, is influenced by the cool winter conditions during previous ENVI-met studies, which mainly considered summer or warmer periods. Nearby trees and building models may behave differently in winter compared to summer, as their shade does not significantly affect an already cool ambient temperature.

In New Zealand, a notable gap in previous research is the limited investigation of the impacts of urban elements such as geometry (e.g., aspect ratio, building orientations, sky view factor), surface materials (both buildings and lands), and vegetation (trees, grass, green walls, green roofs) on microclimatic conditions and outdoor thermal comfort. No previous research has conducted a comprehensive analysis of outdoor thermal comfort in urban contexts, particularly in Central Business Districts (CBDs), using field measurements and software simulations. Consequently, classification of the results of past studies in New Zealand remains challenging at this stage.

4.5.6 Results of microclimatic and outdoor thermal comfort studies in New Zealand

As depicted in Figure 4.8, the number of studies that have analysed microclimate and outdoor thermal conditions in New Zealand is relatively limited. Out of the six papers selected for this review, three centered on investigating people's thermal sensation in Christchurch during both winter and summer seasons, employing field measurements and field surveys conducted in urban parks and streets. Furthermore, only one paper explored heat stress conditions in an urban street in Auckland, dating back to the summer of 1985, using field measurements and field observations. The most recent paper focused on the impact of urban contexts on residential

heating energy during the winter season in Wellington, employing a combination of field measurements and software simulations. This limited number of studies highlights the need for more comprehensive research in the field of microclimate and outdoor thermal conditions in New Zealand.

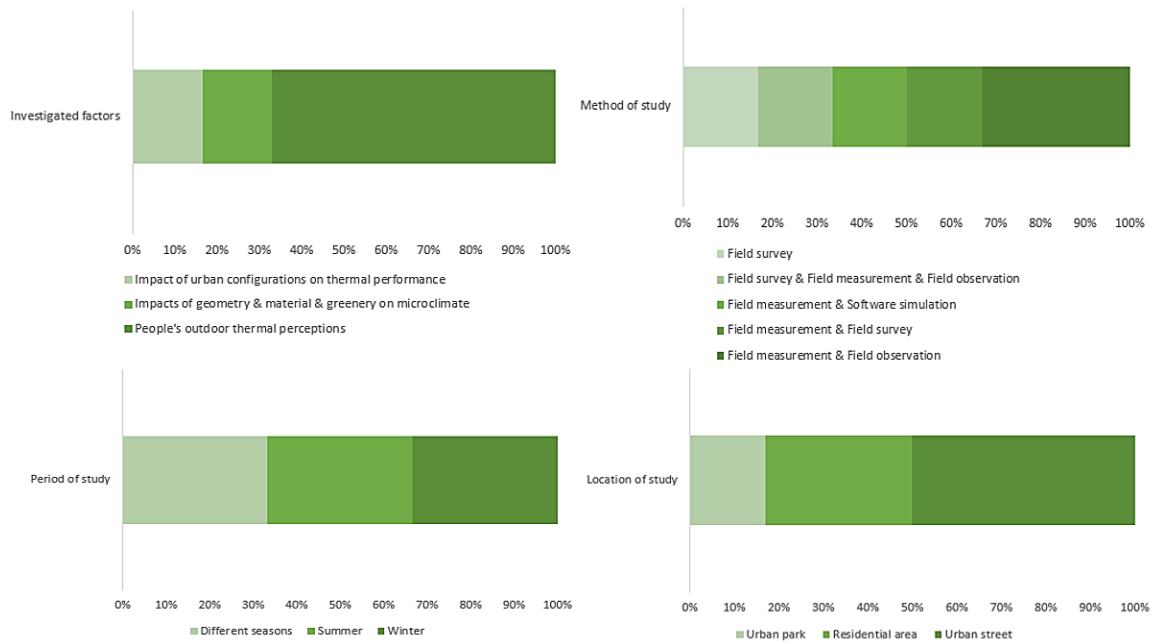

Figure 4.8 Results of microclimate and outdoor thermal comfort studies in New Zealand

4.6 Discussion

This review of studies on previous urban microclimatic and outdoor thermal comfort in cities of Australia and New Zealand has demonstrated that such studies are limited in terms of the following research elements: study areas, factors analysed, methods utilised and the study period (Figure 4.9).

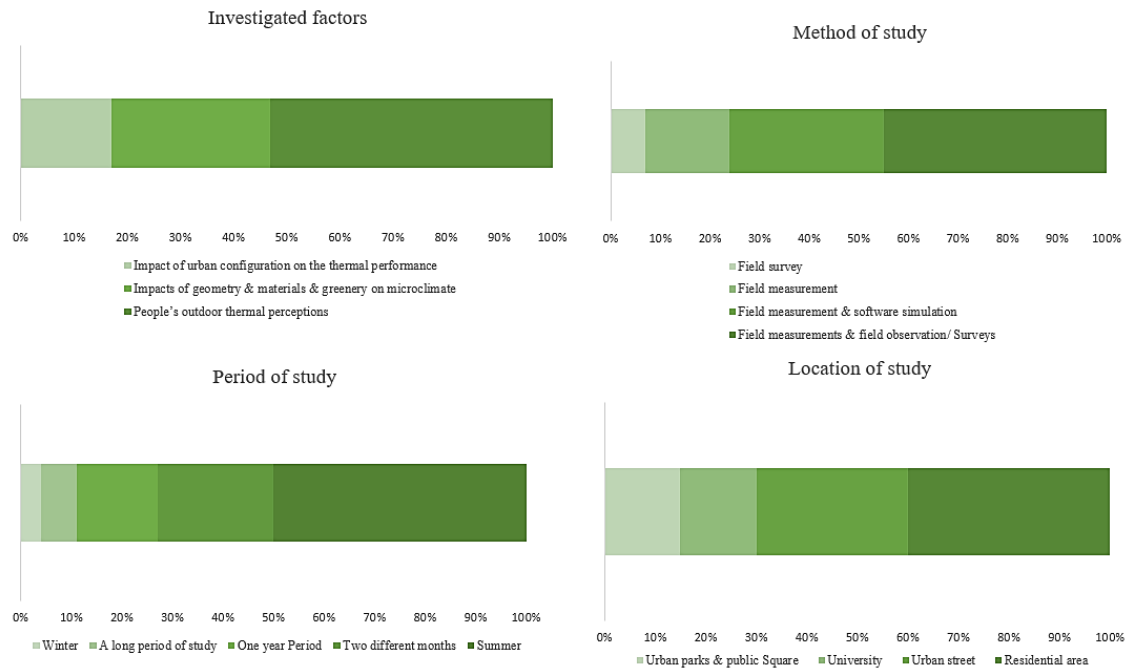

Figure 4.9 Results of microclimatic and outdoor thermal comfort studies for all selected papers

- Study area: In all the selected papers, there is limited research on outdoor urban places that have a significant role in people gathering (e.g. commercial areas, urban parks, squares and universities), whereas reasonable numbers of prior studies examined residential neighbourhoods and urban streets.
- Factors analysed: About half of the previous studies analysed people's outdoor thermal perceptions. However, effects of urban configurations play vital roles in thermal sensations. Analysing different factors would provide more accurate results.
- Method utilised: Nearly 45% of selected papers used field measurements and field surveys. A combination of field measurement and field surveys with computer modelling is the most effective approach for studying microclimates.
- Study period: Around 50% of studies were conducted in the summer. Although Australia and New Zealand may not face many severe climatic issues, concentrating on winter is important for these countries, especially considering potential climate change.

Additionally, understanding thermal comfort during winter is critical for designing buildings and outdoor spaces that are comfortable and energy-efficient throughout the year.

In summary, to achieve comprehensive results in analysing microclimate and outdoor thermal comfort in Australia and New Zealand, future researchers should concentrate on locations that play a significant role in encouraging outdoor living and gathering in urban areas. Additionally, they should investigate the impacts of urban configurations, including building geometry, materials, and greenery, on creating diverse microclimate conditions. Utilizing various software simulation tools throughout the year is essential to achieve the best scenario for improving outdoor thermal comfort.

4.7. Conclusion

The study of microclimate and outdoor thermal comfort in Australia and New Zealand is an emerging area of interest, but there is currently a shortage of research in these regions. Given the distinct and unique climates in these countries, research conducted in other parts of the world may not be directly applicable. Therefore, it is crucial to conduct research tailored to the specific climatic conditions of Australia and New Zealand to ensure accuracy and relevance. This paper aims to review existing studies in these countries, provide a foundation for future research, identify research gaps, and highlight areas requiring further investigation.

The novelty of this study lies in addressing the climatic challenges in urban design to enhance outdoor thermal comfort year-round, particularly considering current and predicted climate patterns in cities across Australia and New Zealand. This research carries significant implications for architects and urban designers working on designs to improve outdoor thermal conditions in these countries.

The literature review reveals a limited amount of research on microclimatic and outdoor

thermal comfort studies in Australia and New Zealand. The most common theme in the reviewed papers was the analysis of people's thermal perceptions in residential areas during the summer, primarily using field measurements and surveys. However, the focus of the selected studies in Australia is predominantly on urban spaces in Melbourne and Sydney, which have temperate climates. A more comprehensive understanding of outdoor thermal comfort in Australia requires the analysis of microclimate conditions in various cities, including those often neglected, such as Darwin with its high humidity and heavy rains.

In contrast, drawing conclusions about New Zealand's microclimate and outdoor thermal comfort is challenging due to the limited number of studies, neglect of urban morphology effects, and the lack of research in Central Business Districts (CBDs). Prior studies have not provided solutions to mitigate the effects of wind speed, rainfall, and the impacts of urban contexts on microclimate conditions.

In conclusion, past studies in Australia and New Zealand have highlighted the significant role of greenery in improving microclimatic conditions and outdoor thermal comfort, particularly during summer. Future research should explore how greenery can mitigate the impacts of climate change on outdoor thermal comfort in urban contexts. Additionally, there are substantial gaps in our understanding of the effects of urban geometry and materials on microclimatic conditions and outdoor thermal comfort in current and future settings, which should be addressed by future research. Given the current and predicted climate patterns in these countries, addressing climatic challenges in urban design to enhance outdoor thermal comfort throughout the year is essential. The identified research gaps should guide the development of a comprehensive guideline for Australia and New Zealand in future studies, with architects and urban designers considering these factors when creating new designs to improve outdoor thermal conditions.

Chapter 5 Summer Outdoor Thermal Risk Area Mapping on a University Campus in Auckland, New Zealand

5.1 Prelude

Chapters 2, 3, and 4 lay out the criteria for selecting a case study location in Auckland, New Zealand, addressing previous gaps and proposing recommendations for future research. Building on these results, Chapter 5 focuses on Auckland University of Technology (AUT) as a precise case study location. This choice is informed by the identified concerns in high-density and intensity areas exposed to urban heat island effects, predicted climate change, and population growth. AUT, characterized by diverse urban design elements, including varied geometries, materials, and a conducive environment for field surveys, offers insights into the effects of urban planning on microclimate. Chapter 4 reveals a specific gap in identifying outdoor thermal risk areas in both New Zealand, emphasizing the need to pinpoint locations with high thermal stress and intense human presence. In this chapter, the aim is to identify outdoor thermal risk areas at AUT using distinct methodologies, offering a valuable template for future studies across different locations. Given the focus on summer due to predicted climate change, the chapter examines current and future summer conditions in Auckland. The mitigating scenario centres on the role of greenery, aligning with previous recommendations. Results show that trees and green walls significantly reduce Physiological Equivalent Temperature (PET) levels in identified thermal risk areas during summer, providing practical insights for urban planners and architects to enhance the liveability of outdoor spaces in various urban contexts.

5.2 Introduction

Over the past few decades, urbanization has resulted in transformations in the physical structure and form of cities (Zhou & Chen, 2018). The complexity of urban areas, characterized by

variations in urban densities, layout typologies, and architectural forms, gives rise to intricate microclimate conditions (Natanian et al., 2019, Heris et al., 2020). The perception of the outdoor thermal environment by an individual can be influenced by both the outdoor climate and the surrounding built environment (Lin et al., 2010). An inadequately designed environment can also impact microclimate conditions, potentially compromising thermal comfort (Huang et al., 2018). Therefore, a significant number of research studies have focused on analysing the microclimatic conditions of various urban contexts around the world for improving the level of outdoor thermal comfort (Ramyar et al., 2019, Rosso et al., 2022).

The majority of prior research has delved into examining how various urban design scenarios affect the microclimate conditions within urban spaces. These investigations have been conducted through a combination of simulations and field studies. Numerous studies have specifically concentrated on understanding the concept of outdoor thermal comfort in diverse climatic and spatial settings (Aghamolaei et al., 2023). For instance, Lai et al. discussed cooling effects of four mitigation strategies, namely, changing the form and geometry of built-up areas, green spaces, water bodies, and cool surfaces and roofs (Lai et al., 2019). Jamei et al. evaluated the impact of urban greening and building geometry on formulating mitigation strategies for improving outdoor thermal comfort at the pedestrian level (Jameiw et al., 2016). Aghamolaie et al. reviewed differences in outdoor thermal comfort sensations and preferences between older people and other age groups (Aghamolaei & Lak, 2023). Taleghani reviewed the effect of urban heat island mitigation strategies on human thermal comfort in urban spaces (Taleghani, 2018). Santos Nouri examined various assessment approaches for determining local outdoor thermal comfort thresholds with urban design (Nouri et al., 2018). Chen et al reviewed studies on outdoor thermal comfort, concerning the experiences and perceptions of pedestrians (Chen & Ng, 2012). Lin et al. reviewed Strategies and guidelines in the field of landscape architecture to create thermally comfortable outdoor spaces (Lin & Brown, 2021). Azevedo evaluated

existing climate and comfort policies, and difficulties arising during the assessment of local actions and guides (Azevedo & Leal, 2017). Zhao et al. reviewed adaptive thermal comfort models, with a focus on data-driven techniques in both indoor and outdoor comfort modelling (Zhao et al., 2021). Johansson scrutinized instruments and methods employed in outdoor field studies, as well as the requirements for standardizing subjective assessment tools (Johansson & Emmanuel, 2006).

While there is a significant number of research analysing outdoor thermal comfort in various locations, there is a notable gap in previous studies. This gap pertains to identifying outdoor thermal risk areas, which means areas not only experiencing a high level of outdoor thermal discomfort but also having a high intensity of individuals and usages. Especially considering the importance of predicted climate change and population growth worldwide, it is vital for urban planners to identify high thermal risk areas within cities as a priority. In terms of outdoor thermal risk, we adhered to the risk concept outlined in the IPCC's Fifth Assessment Report (AR5). Previous studies have similarly embraced the IPCC's risk assessment concept, considering perspectives from hazard, vulnerability, and exposure in their research (Norton et al., 2015, Huang et al., 2018, Hua et al., 2021, Paranunzio et al., 2021). The previous study by Huang et al. (Huang et al., 2018), considered the primary methodological approach for this research. However, we endeavoured to enhance this methodology and apply it to various locations for future research. To be more precise, while Huang et al. aimed to prepare the vulnerability layer through in-situ observations and found that residents generally exhibit greater familiarity with the local environment, possessing relatively abundant knowledge, experiences, or resources to adapt to the local climate, resulting in lower vulnerability to thermal stress than tourists. In our research, we modified the approach to preparing this layer, shifting from in-situ observations to field surveys. This method allows for the identification of high vulnerability areas based on the thermal sensations of all individuals, as determined

through questionnaires. This contrasts with distinguishing between the behaviours of local and non-local people, an approach that cannot be applied to locations that are not tourist attractions. In the methods section, we provided detailed explanations of the methodologies.

Moreover, a relatively small number of studies on urban microclimate and outdoor thermal comfort have been conducted in New Zealand (Tuller, 1980, De Freitas et al., 1985, Tavares et al., 2019, Perera et al., 2020, Isaacs & Donn, 2021, Jalali et al., 2022). Only one paper analysed the heat stress conditions in an urban street in Auckland during the summer, using field measurements and observations (De Freitas et al., 1985). Based on the National Institute of Water and Atmospheric Research in New Zealand (NIWA), the average summer temperature in Auckland was 20°C, with an average high of 23°C and a low of 17°C. Initially, considering the current conditions, thermal stress does not seem to be a significant concern in Auckland. However, both average and maximum temperatures are likely to rise due to the phenomenon of climate change. The frequency of hot days in Auckland, New Zealand, is expected to increase (Mullan et al., 2016). Days with temperatures above 25 °C is anticipated to rise by 40 to 100 percent before 2040, and from 40 to 300 percent by 2090 (Mullan et al., 2016). For example, according to the Auckland central weather forecast and observations, the hottest day of the summer in the first part of January 2024 was recorded at 27.9 °C. Moreover, Auckland has a population of 1.66 million people, which is expected to increase by 720,000 to 2.4 million in the next 30 years (Source: Auckland City Council). Therefore, analysing the current outdoor thermal comfort and identifying thermal risk areas in Auckland is necessary, specifically considering the increase in air temperature and population, which may create more risk areas in the future. Urban planners and architects should design guidelines for improving outdoor thermal conditions in Auckland. For this research, we specifically selected the dates of March 14th and 15th, with average temperatures of 20°C and 20.2°C, as representative summer days with similar average temperatures to the historical average in Auckland. In this study, the period

between 12:00 and 13:00 was chosen to identify thermal risk areas. This timeframe corresponds to lunchtime at the university, when the selected locations experience the highest intensity of human presence throughout the day, peaking in activity. This choice allows us to observe and interact with a significant number of students, helping us prepare the exposure and vulnerability layers.

Moreover, based on field measurements and Envi-met results from 12:00 to 13:00 on March 14th and 15th, the average air temperature was recorded as 20.82 °C, the average wind speed as 2.04 m/s, and the average humidity as 69.88%. By comparing this with historical weather data for Auckland, we determined that this specific time can be a good representative sample of Auckland's weather conditions for analysing outdoor thermal stress during summer.

For selecting a location as a case study, we decided to choose an area in the Central Business District (CBD) of Auckland. This area is the most populated and utilized part of Auckland, making it a priority for identifying thermal risk areas, especially when considering the impacts of urban heat islands. Furthermore, the effects of urban planning, particularly the use of different materials and high-rise buildings with less greenery, on the microclimate are highlighted. We selected Auckland University of Technology as a sample area in the CBD because this location not only comprises various urban design elements, including different geometries and materials, but also provides a conducive environment for conducting field surveys and gathering perceptions on outdoor thermal comfort from individuals of diverse ages and nationalities.

Given the limited research on identifying outdoor thermal risk areas and the attempt to modify the methodology for identifying high thermal risk areas applicable to various urban areas, coupled with the absence of previous studies focusing on outdoor thermal comfort conditions in Auckland, New Zealand, specifically considering predicted climate change and population

growth in this city, and attempting to define new scenarios for mitigating thermal stress based on the specific characteristics of each location, the primary objectives of this study, aligned with these concerns, are as follows:

1. To identify outdoor thermal risk areas in the selected locations within of Auckland University of Technology (AUT) based on current microclimate conditions.
2. To predict future thermal comfort conditions of the identified thermal risk areas based on future climate patterns.
3. To assess the impact of the use of greenery on high thermal risk areas.

5.3 Method

5.3.1 Research structure

This research consists of two steps. In step one, the two most crowded outdoor areas of AUT are identified, and step two is divided into three different phases. In phase one, we examined outdoor thermal risk areas. The initial phase of the study involved the establishment of three distinct layers: the hazard layer, exposure layer, and vulnerability layer, for the selected locations. Each layer was constructed using a combination of field measurements, field observations, field surveys and software simulations. By overlaying the layers of hazard, exposure, and vulnerability, areas with high thermal risk were identified. To assess the future changes in thermal comfort (hazard layer) through simulations in phase two, data from two future time periods were considered. And finally, for phase three, we examined new scenarios to mitigate thermal stress (hazard layer) in these areas (Figure 5.1).

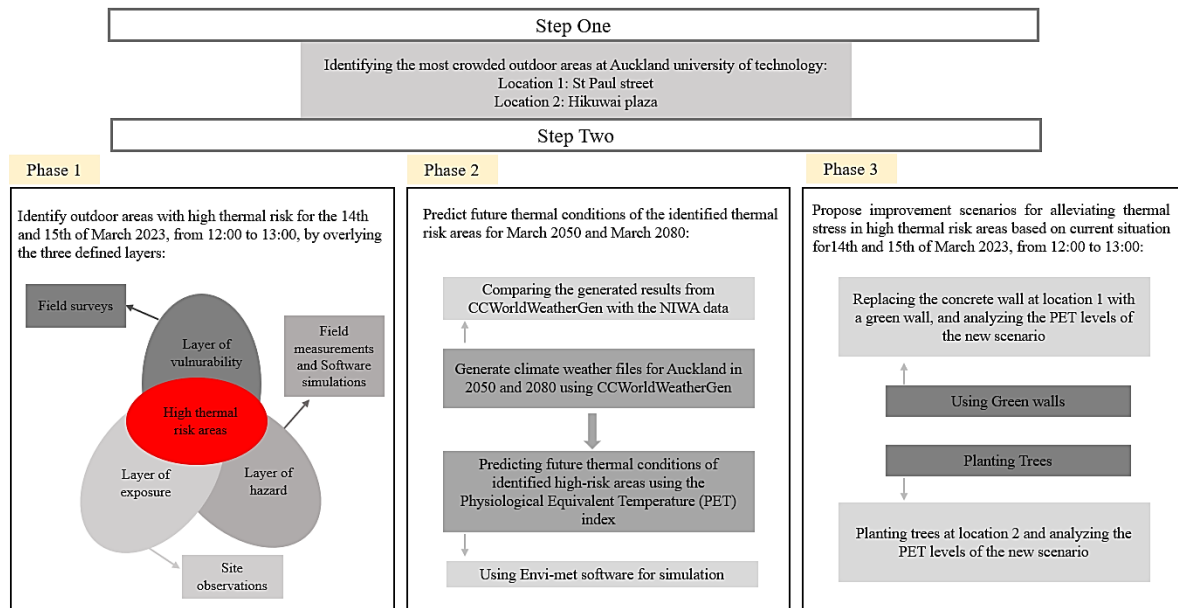

Figure 5.1 The structure of the research

The research location is the city campus of Auckland University of Technology (S-36° 51', E174° 46'). To identify outdoor thermal risk areas at this university, we selected two highly frequented outdoor places. The first is a street called St Paul, measuring 200*15m, which is surrounded by nine different buildings ranging from 8m to 48m in height. The main materials used for these buildings are glass, concrete, and steel, with a combination of asphalt and concrete pavements. The second location is a plaza called Hikuwai, covering an area of 900m², and it is surrounded by three different buildings ranging from 8m to 24m in height. These buildings are constructed using glass, concrete, and steel materials. Both locations have limited vegetation coverage.

5.3.2 Defining the layer of hazard (Phase 1a)

In this study, the term "hazard" pertains to the presence of thermal stress in a particular area (Huang et al., 2018). To assess the risk associated with thermal stress, the research utilized the Physiological Equivalent Temperature (PET) index. The PET index serves as a metric for evaluating the level of thermal risk present in a specific location (Höppe, 1999, Blazejczyk et al., 2012). Higher PET values indicate a greater degree of thermal risk within the examined

area (Huang et al., 2018). In more details, PET (The Physiologic Equivalent Temperature), PMV (Predicted Mean Vote), and UTCI (Universal Thermal Climate Index) are the three most used indices. They share similar characteristics: being universal indices applicable in both cold and hot thermal conditions, covering a wide range of thermal sensation or stress classifications, and comprising 7 to 10 categories (Potchter et al., 2018). We selected PET for this study as Lam et al. (Lam et al., 2021) conducted a review revealing that among the selected prior studies, over 55% utilized PET as a thermo-physiological assessment index. PET is widely favoured in many research endeavours for two primary reasons. A significant portion of outdoor thermal comfort investigations has concentrated on summer heatwave conditions. The PET, featuring a two-node body model encompassing both clothing-covered and uncovered segments, encounters challenges in calculating the clothing section. Nevertheless, this limitation proves manageable during the summer season, as individuals typically wear lightweight clothing. Additionally, the results derived from PET prove beneficial for comparative studies involving diverse spatiotemporal variations, given the prevalence of its usage in several studies (Chen & Matzarakis, 2018). Envi-met is employed to model the complete thermal environment, a capability that has been affirmed through numerous research endeavours demonstrating its efficacy in replicating neighbourhood-scale thermal conditions (Shinzato et al., 2019, Lachapelle et al., 2022). Envi-met is a three-dimensional microclimatic model with a one-dimensional boundary model, three-dimensional atmospheric model, soil model, and plant model (Chatzinikolaou et al., 2018, Rui et al., 2019). The study grid measures 2 m x 2 m x 2 m and is based on a model with a grid size of 200 x 100 x 60 and 220 x 180 x 40.

The validity of the simulated data was assessed by comparing observed and simulated meteorological data values. We conducted field measurements, using the Davis 6152 Wireless Vantage Pro2 weather station (Figure 5.2). The Vantage Pro2 uses high-quality sensors that are designed to provide accurate and reliable measurements of temperature, humidity, wind speed,

direction, and rainfall. The sensors used in the Vantage Pro2 are accurate to within ± 0.5 °C for temperature, $\pm 2\%$ for relative humidity, ± 2.2 km/h for wind speed, and $\pm 5\%$ for rainfall. Two locations on St Paul Street and Hikuwai Plaza were selected for field measurements based on their potential to provide diverse degrees of shade. The sensors were placed at pedestrian level with a height of 1.5 meters during the measurement process. The meteorological conditions at these locations were constantly monitored and recorded every 30 minutes from 8:30 to 16:30 on March 14, and March 15, 2023.

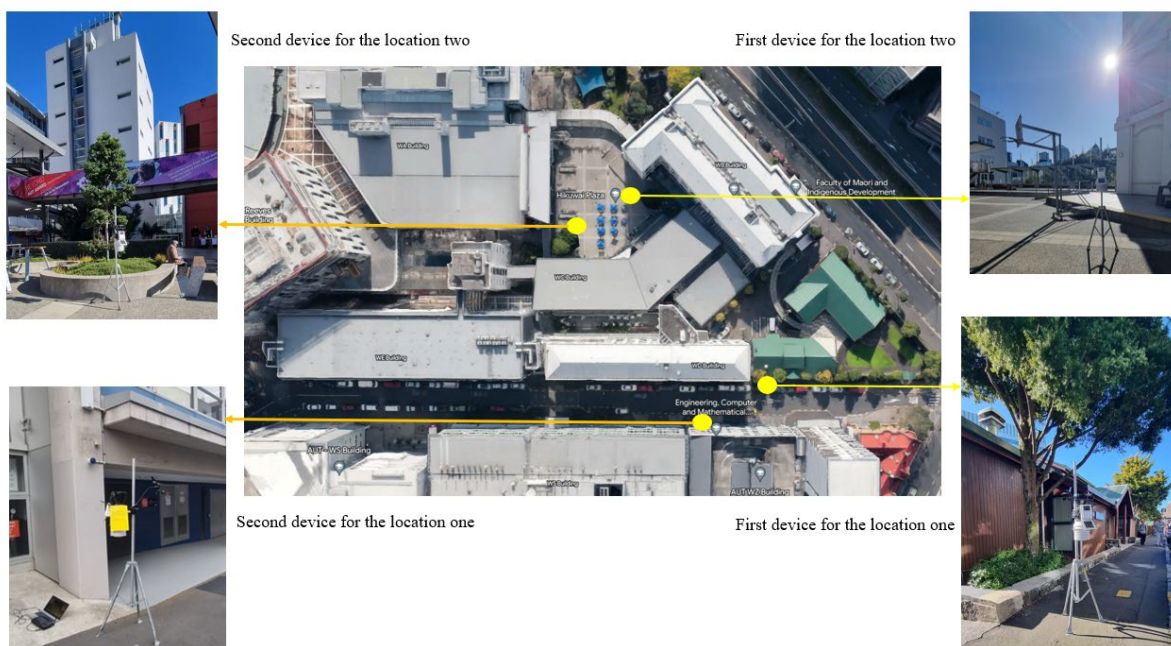

Figure 5.2 The locations of Davis 6152 Wireless Vantage Pro2 weather stations

After conducting field measurements and software simulations, we attempted to determine the distribution of both the field measurements and simulated data generated by Envi-met software. To achieve this, we employed a statistical test known as the Shapiro-Wilk test to assess whether the field measurements and simulated data from Envi-met at both location 1 and location 2 adhere to a normal distribution. The Shapiro-Wilk test is especially useful when dealing with relatively small sample sizes ($n < 50$) (Shapiro & Wilk, 1965). The null hypothesis of the Shapiro-Wilk test is that the data in the sample is normally distributed.

To ascertain the agreement between field measurements and Envi-met simulated data, we employed various methods. Specifically, R-squared is a commonly used metric to evaluate the concordance between measured and simulated data. Nevertheless, it is crucial to note that R-squared is not the sole measure to consider when comparing these datasets, particularly if the assumptions of linear regression are not entirely satisfied. The key assumptions are Linearity, independency of residuals, homoscedasticity, normality of residuals and no perfect collinearity between independent variables (Hastie & Pregibon, 2017). High R-squared values can occur even when the relationship between the datasets is spurious or coincidental. Therefore, it is essential to complement the R-squared evaluation with other methods, such as visualizations and statistical tests, to gain a comprehensive understanding of the agreement or differences between the measured and simulated data (Allison, 2013).

In this research, various methods were employed to assess these assumptions. Scatter plots to verify the linearity, Durbin-Watson statistical test to detect the presence of auto correlation in the residuals, Q-Q plot along with Shapiro-Wilk statistical test to check the normality of residuals, and finally the Residual vs. Fitted Values Plot to check homoscedasticity. No collinearity assumption does not apply to this problem as a single predictor variable is considered.

5.3.3 Defining the layer of exposure (Phase 1b)

In this study, exposure is defined as the spatial intensity distribution of individuals using the outdoor space (Huang et al., 2018). The level of exposure is determined by the concentration of people gathered in a particular area. Higher exposure is observed in areas with a larger number of individuals present. This data was utilized to calculate the usage intensity of the area, providing insight into the degree of exposure experienced by the space users (Huang et al., 2018). The construction of the exposure layer involves a stepwise process. Firstly, the locations were divided into zones. In this study, we divided two specific locations into zones

based on the arrangement of sitting facilities and shading conditions. St Paul Street (location one) was divided into three zones, while Hikuwai Plaza (location two) was divided into five zones. Secondly, the number of individuals within each zone was hand-counted specifically from 12:00 to 13:00 on March 14th, 2023, for location one, and on March 15th, 2023, for location two by researchers monitoring the areas. Thirdly, the usage intensity of each zone was determined by dividing the number of people within that zone by the total number of people present in the entire selected locations during the same time (Sara et al., 2016, Huang et al., 2018).

5.3.4 Defining the layer of vulnerability (Phase 1c)

Individuals exhibit diverse perceptions of thermal comfort, leading to variations in their durability and vulnerability to thermal stress (Lin & Matzarakis, 2008, Huang et al., 2018). To assess the vulnerability of people in this research, a questionnaire was employed. On March 14th, 2023, for location one, and on March 15th, 2023, for location two, questionnaires were administered between 12:00 and 13:00, to identify high thermal risk areas, it is necessary to generate three different layers within the same time. Due to resource limitations, it was not possible to collect data from every individual present at the locations. However, efforts were made to conduct questionnaires with as many participants as feasible. To ensure a representative sample, participants of different genders and ages were selected (Appendix A, Table 1).

The questionnaires encompassed inquiries about participants' subjective thermal sensations, their perception of comfort, and their preferences regarding environmental factors such as humidity, wind speed, and air temperature. Moreover, relevant physical attributes including age, gender, clothing type, and level of activity were recorded, A sample questionnaire is available in Appendix B. Additionally, the location of each participant was marked on the map to aid in identifying areas where individuals experienced uncomfortable conditions.

Moreover, A violin plot and bubble plots were utilized to explore the relationship between respondents' thermal sensation and the PET index (comprising layers of hazard and vulnerability). The outline of each violin plot depicts the frequency distribution of PET indices corresponding to different thermal sensations observed at the respective locations.

For bubble plots, the relationship between the mean respondents' thermal sensation and the PET index can be modelled using linear regression. The regression equation represents the mean respondents' thermal sensation as a function of the PET index, expressed mathematically as a linear function: $TSV = m \cdot PET + c$. Here, 'm' denotes the PET coefficient or slope of the regression line, and 'c' is the intercept, referred to as the deviation constant. The coefficient 'm' quantifies the changes in thermal sensation per unit of PET change.

5.3.5 Future PET predictions for summer (Phase 2)

Due to predicted climate change and urban population growth worldwide, many previous researchers have analysed the future conditions of outdoor thermal comfort (Fong et al., 2019, González et al., 2020). In this study, after identifying outdoor areas with a high thermal risk, the research proceeded to examine the future conditions of thermal comfort within these areas (the hazard layer). Predicting exposure and vulnerability layers for the future is not possible because these layers depend entirely on the presence of people. However, we attempted to anticipate the future conditions of the hazard layers in high thermal risk areas by assuming that these areas will also have high exposure and vulnerability in the future. NIWA (National Institute of Water and Atmospheric Research) prepared climate change projections and impacts for the Auckland Region, considering different future periods such as 2050 and 2080 (Eames, 2017). For this study, the summer of 2050 was selected as the midterm future scenario, while the summer of 2080 represented the far future.

To achieve this, climate weather files for Auckland in 2050 and 2080 were generated using the climate change world weather file generator (CCWorldWeatherGen), a tool that has been used in previous research studies with similar objectives (Nielsen & Kolarik, 2021, Tahir et al., 2022). This tool, based on Microsoft Excel, enables us to generate climate change weather files that can be used in building performance simulation programs. It transforms 'present-day' EPW weather files into climate change EPW weather file (Jentsch et al., 2013), which is compatible with Envi-met for simulating outdoor thermal comfort.

The assessment investigates climatic projections following RCPs of 8.5, which represents the highest level of carbon emissions. In Auckland, for RCP8.5 in 2050, most of the region projects increases in annual Tmax of 0.75 °C -1.25°C. In 2080, 2.75°C -3.25°C increase in annual Tmax is projected for most of the region. Subsequently, Envi-met was employed to simulate the microclimate conditions within the selected locations. The assessment of thermal conditions in future scenarios was conducted using the PET index, which served as a metric for evaluating thermal comfort.

5.3.6 Defining new scenarios (Phase 3)

After identifying the outdoor areas with thermal risk and analysing the future thermal comfort (hazard layer) based on climate predictions, the study proceeded to design new scenarios aimed at reducing PET (hazard layer) in risk areas. For this paper the new scenarios are limited to the use of greeneries, such as incorporating trees and green walls. The objective was to identify a new scenario for each location that would effectively mitigate thermal stress and enhance thermal comfort.

5.4 Results and Discussion

The methodology described in section 5.3 detailed the establishment of three separate layers: thermal stress, space usage intensity, and user vulnerability. These layers were developed to

enable an effective assessment of the outdoor thermal risk present in specific locations. By overlaying these layers, it becomes feasible to visually identify and distinguish the various levels of outdoor thermal risk present within the chosen areas.

5.4.1 Preparing the layer of hazard (thermal stress)

We conducted field measurements from 8:30 to 16:30 on March 14th at location 1 (St. Paul Street) and on March 15th at location 2 (Hikuwai Plaza). The results obtained from the field measurements, including air temperature wind speed, and humidity were then compared with the corresponding data simulated by the Envi-met software.

Distribution of Field Measurements and Simulated Data by Envi-met software:

The results of Shapiro-wilk test indicated that the field measurements and simulated data by Envi-met for air temperature (°C), humidity (%), and wind speed (m/s) in location 1 follow a normal distribution. However, in location 2, the field measurements and simulated data for air temperature (°C) and humidity (%) also follow a normal distribution. Nevertheless, for wind speed, they do not follow a normal distribution, as the p-value is less than the significance level of 0.05. The mean and standard deviations are presented in Table 5.1.

Table 5.1 Mean(μ) and standard deviation (σ) of field measurements and simulated data by Envi-met for Location1 (St. Paul Street) and Location2 (Hikuwai Plaza)

Location1			Location2		
Air Temperature (°C)					
Data	Mean(μ)	SD (σ)	Data	Mean (μ)	SD (σ)
Field Measurements	20.1	0.82	Field Measurements	19.14	0.65
Envi-met	19.55	0.85	Envi-met	19.30	0.73
Humidity (%)					
Data	Mean (μ)	SD (σ)	Data	Mean (μ)	SD (σ)
Field Measurements	70	5.68	Field Measurements	57.67	4.57
Envi-met	69.67	5.34	Envi-met	60	4.77
Wind Speed (m/s)					
Data	Mean (μ)	SD (σ)	Data	Mean (μ)	SD (σ)
Field Measurements	1.96	0.47	Field Measurements	1.07	0.76

Agreement between Field Measurements and Envi-Met Simulated Data:

The results indicate that the assumptions of linear regression were satisfied for both Air Temperature and Humidity. Consequently, the R-squared metric was employed to assess the concordance between field measurements and the simulated data produced by Envi-met for these two parameters. The obtained R-squared values were 0.9537 for air temperature at Location 1 and 0.9497 at Location 2, revealing a robust alignment between the measured and simulated data at both sites. In terms of Humidity, R-squared values of 0.9629 (Location 1) and 0.9497 (Location 2) were observed, similarly affirming a strong agreement between the measured and simulated data at both locations. However, it should be noted that the assumption of normality of residuals was not satisfied for wind speed in either location (Figure 5.3).

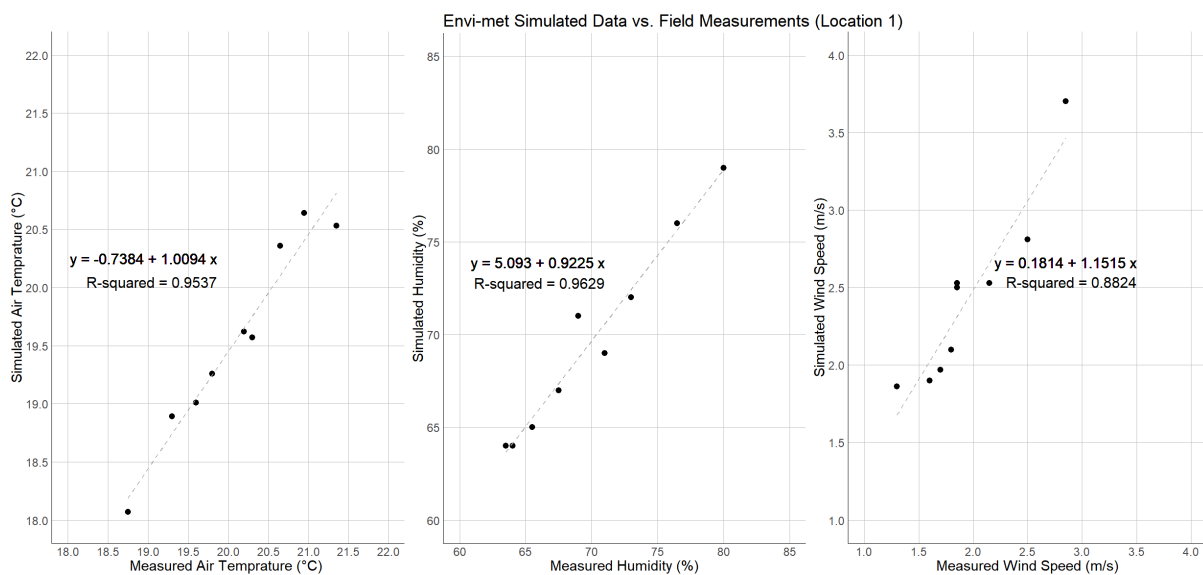

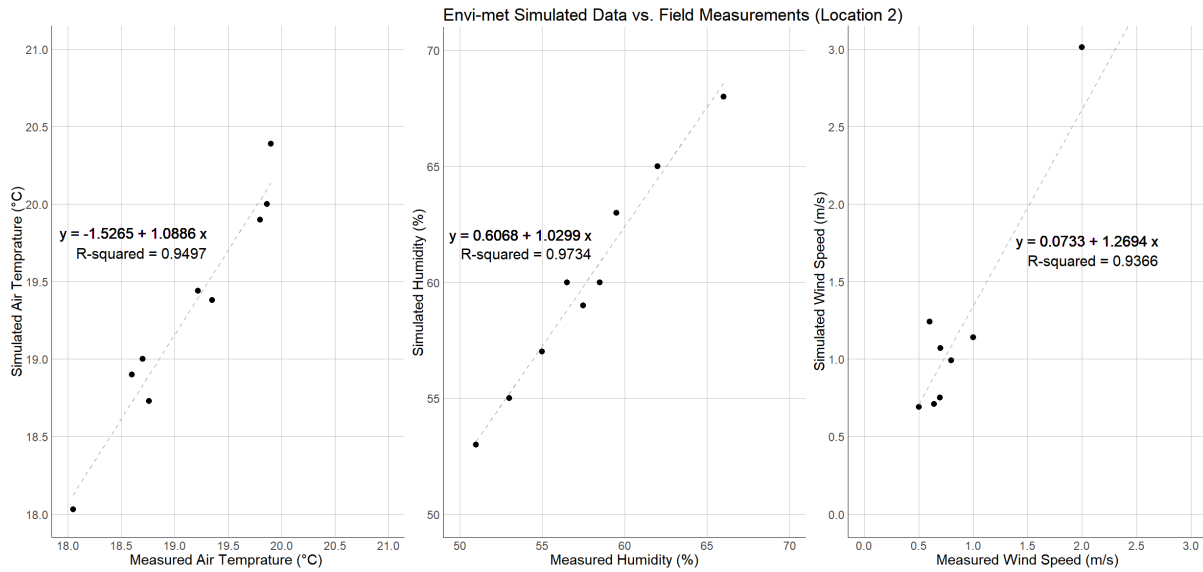

Figure 5.3 Scatter plot illustrating the measured and Envi-met simulated data points, along with the best fit line obtained from linear regression analysis

To investigate these results further and since the linearity assumption is not met for wind speed, density plots were used to visualize the distribution of each dataset, and to provide insights into their shape, spread, and central tendency. By directly comparing the distributions, potential similarities or differences can be identified. As shown in the density plots (Figure 5.4), the distribution of field measurements and Envi-met simulated data for air temperature and humidity are highly similar. However, there are differences in the distribution of wind speed in both locations as expected. For both locations and for wind speed, the density plot of field measurements shows a prominent and higher peak, accompanied by a larger density value. Additionally, the shape of their peaks is notably narrower. These suggest the field measurements tight distribution around values 1.78m/s for location 1 and 0.67m/s for location 2. On the contrary, the density plots of the Envi-met simulated data take on a different appearance. Their peak is comparatively lower in density value, suggesting a lesser concentration of data points. Particularly, their peaks have shifted towards the right, suggesting a deviation from the central tendency observed in the measured data. The disparities in peak height, density value, and shape between the density plots reflects meaningful distinctions in

the distribution patterns of the field measurements and Envi-met simulated data. These variations could potentially arise from underlying factors influencing the generation of the simulated data, emphasizing the importance of careful interpretation when comparing the measurements for wind speed.

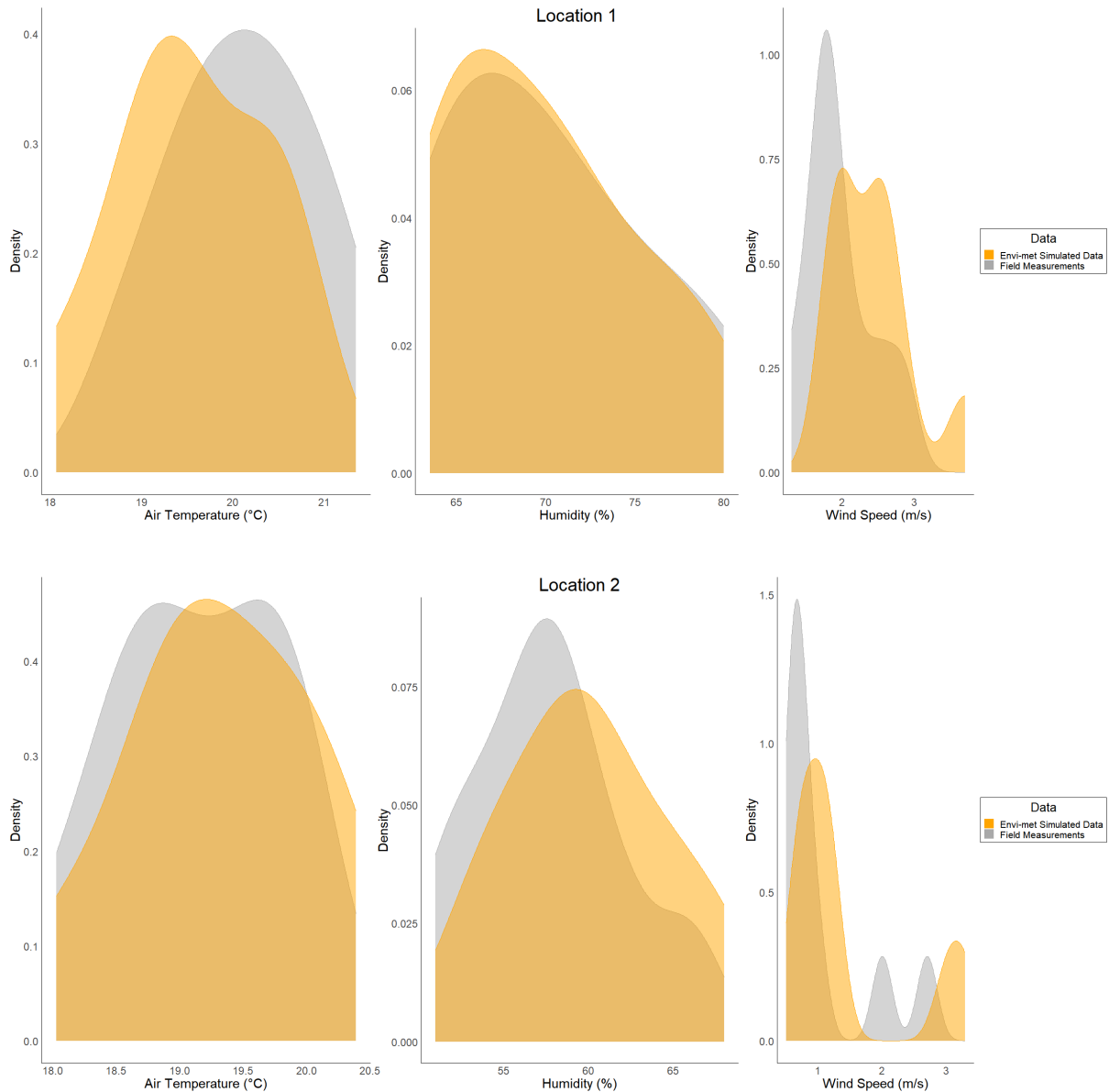

Figure 5.4 Density plots to compare distribution of field measurements and Envi-met simulated data in location 1 and location 2

Based on field measurements and Envi-met results from 12:00 to 13:00 on March 14th, the average air temperature was recorded as 20.82 °C, the average wind speed as 2.04 m/s, and the

average humidity as 69.88% for location 1. As for location 2, the average air temperature, wind speed, and humidity during the period from 12:00 to 13:00 on March 15th were determined as follows: air temperature: 19.93 °C, wind speed: 0.83 m/s, and humidity: 58.22% (Figure 5.5).

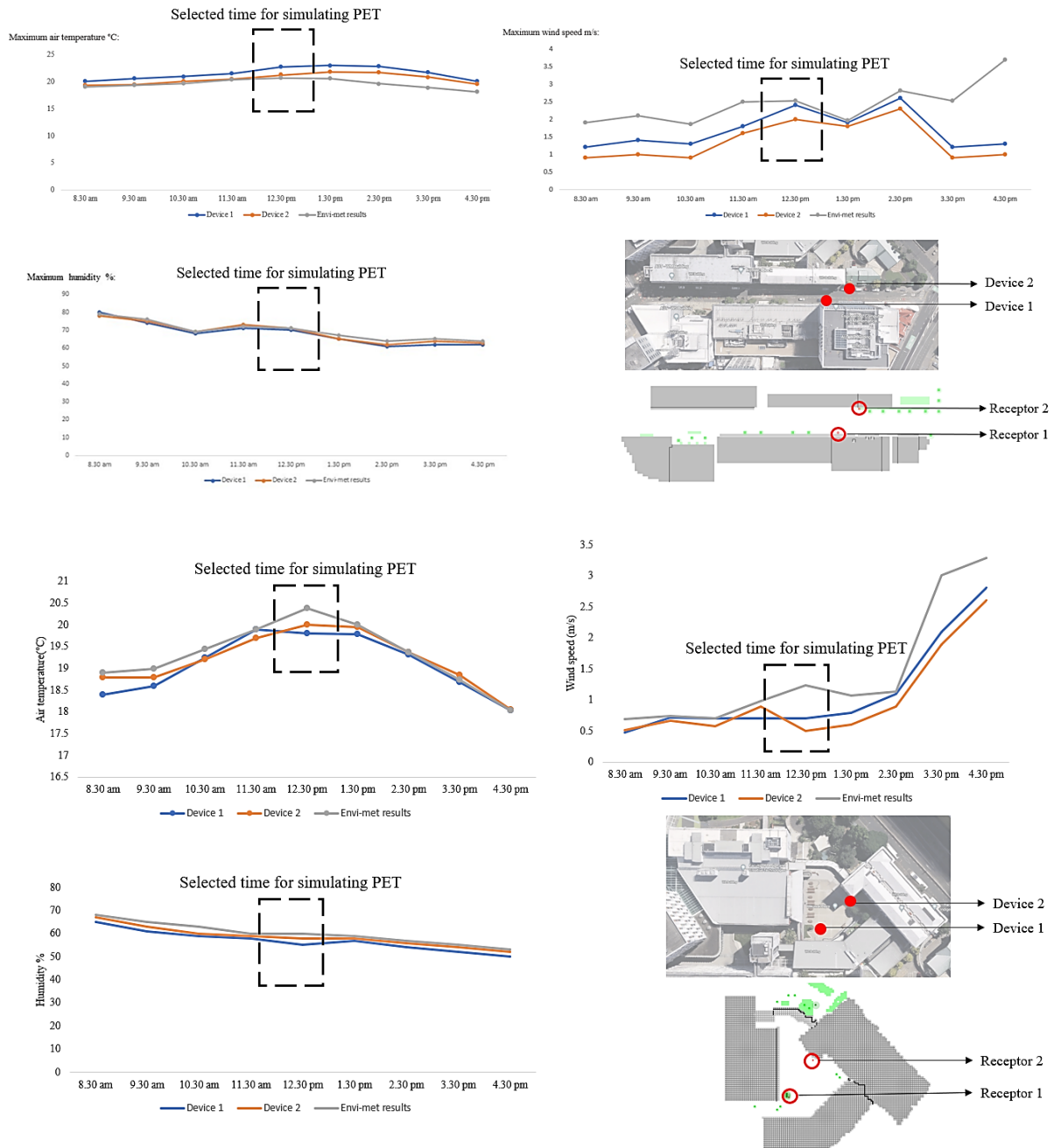

Figure 5.5 The results obtained from the field measurements and Envi-met simulation for air temperature, wind speed, and humidity on March 14, 2023, for location 1 and March 15, 2023, for location 2

In this study, the term 'hazard' refers to environmental thermal stress. Once the accuracy of Envi-met was determined, PET calculations were conducted to identify thermal stress areas in the selected locations. Auckland, characterized by a temperate climate (cfb) according to the Koppen climate classification, has a comfortable PET range between 18°C and 23°C based on a comparison of the modified PET “Neutral” sensation ranges in different climatic zones (Potchter et al., 2018). Figure 5.6 illustrates the PET range for location 1 from 12:00 to 13:00 on March 14th. Based on the results, most parts of the location fall within the comfortable PET range of 19°C to 22°C. Only a few areas within the location experience slight heat stress, with a PET range between 23°C and 24.5°C.

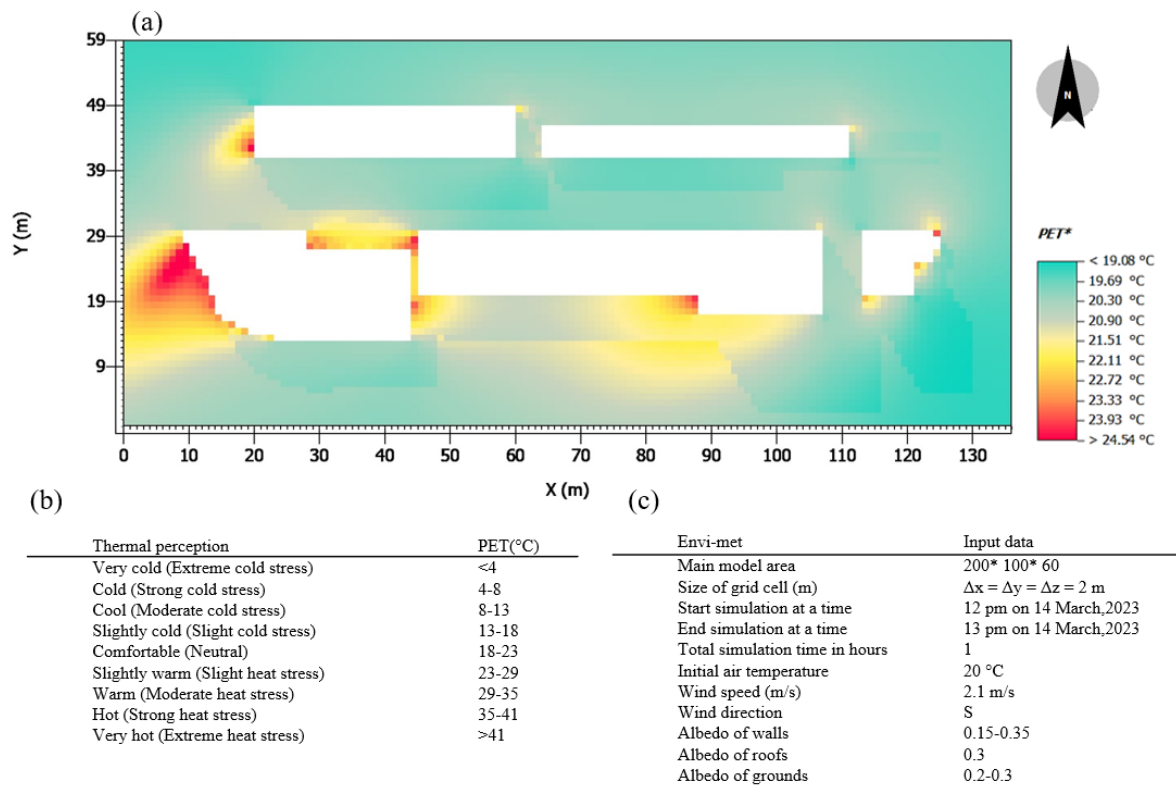

Figure 5.6. a: Layer of hazard for location 1, showing the distribution of thermal stress areas based on field measurements and simulations b: categorization PET level for different thermal perception in a Cfb climate (Potchter et al., 2018) c: the input data for Envi-met

In the case of location 2, as depicted in Figure 5.7, from 12:00 to 13:00 on March 15th, most of the selected area shows slightly warm conditions with slight heat stress, indicated by a PET range between 23°C and 26°C.

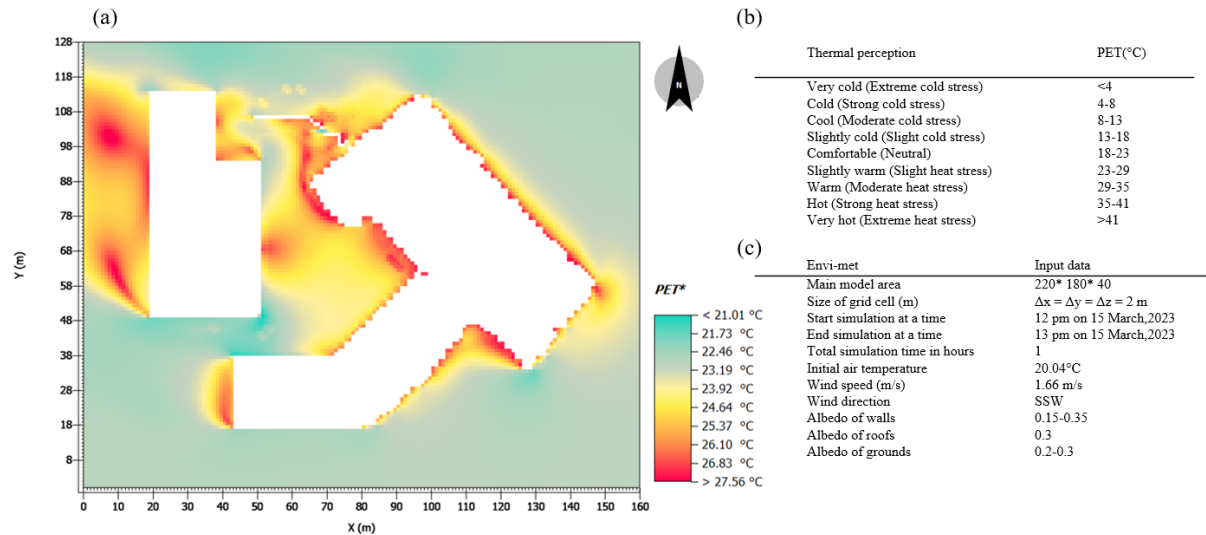

Figure 5.7. a: Layer of hazard for location 2, showing the distribution of thermal stress areas based on field measurements and simulations b: categorization PET level for different thermal perception in a Cfb climate (Potchter et al., 2018) c: the input data for Envi-met

5.4.2 Preparing the layer of exposure (user intensity)

In the context of this study, the risk determinant "exposure" is defined as the intensity of space usage. It is understood that areas with higher intensity of space usage are associated with an increased likelihood of users being exposed to thermal stress (Huang et al., 2018).

In this research, for location 1 on 14 March 2023, we firstly divided the location into 3 zones and then counted the number of people in each zone (Huang et al., 2018) in 6-time sections, with a duration of 10 minutes each, from 12:00 to 13:00. We determined the usage intensity of people on the map, as shown in Figure 5.8. In total, there were 247 people in all zones combined for location 1, with 89 people in zone 1, 52 people in zone 2, and 106 people in zone 3 across all 6 time sections. By dividing the number of people in a selected zone by the total number of

people in the location at a specific time, we obtained the usage intensity of that zone. As depicted in Figure 5.9, zone 3 had the highest exposure with a usage intensity of 0.42 in this location.

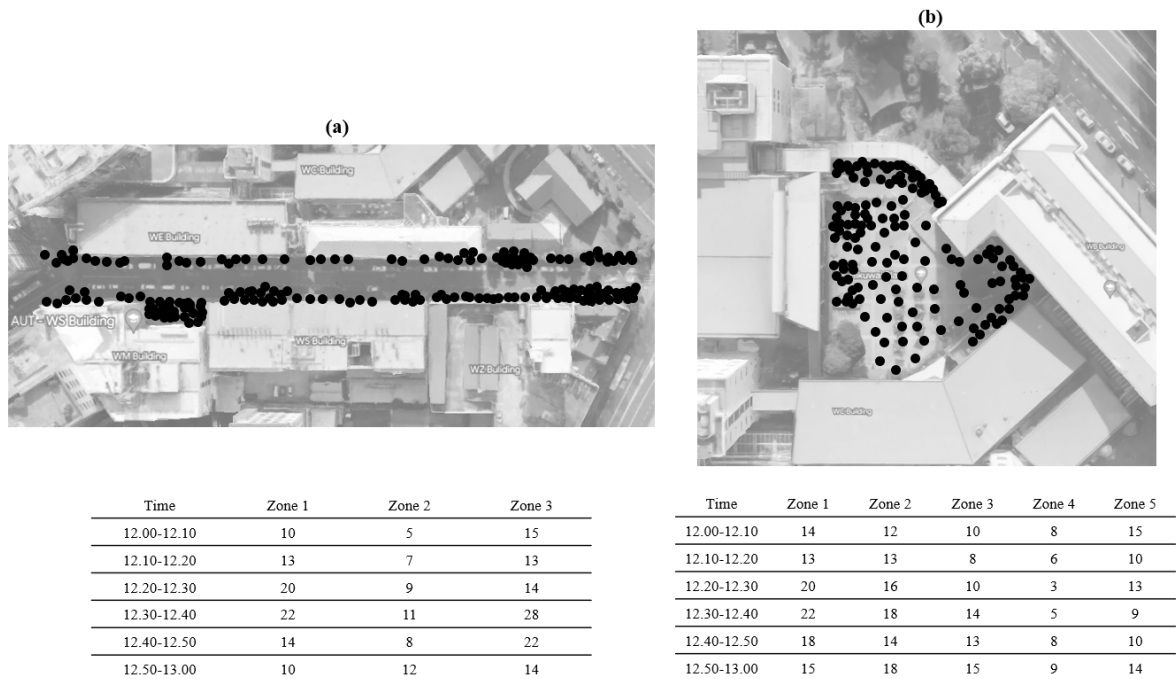

Figure 5.8 Layers of the number of people distribution (a) location 1, (b) location 2

The same method was employed to calculate the usage intensity of location 2 on 15 March 2023 from 12:00 to 13:00. We divided this location into 5 different zones, as shown in Figure 5.8. The results indicated that the total number of people in this location was 373, with 102 people in zone 1, 91 people in zone 2, 70 people in zone 3, 39 people in zone 4, and 71 people in zone 5. Based on Figure 2.9, zone 1 had the highest exposure with a usage intensity of 0.27 in location 2.

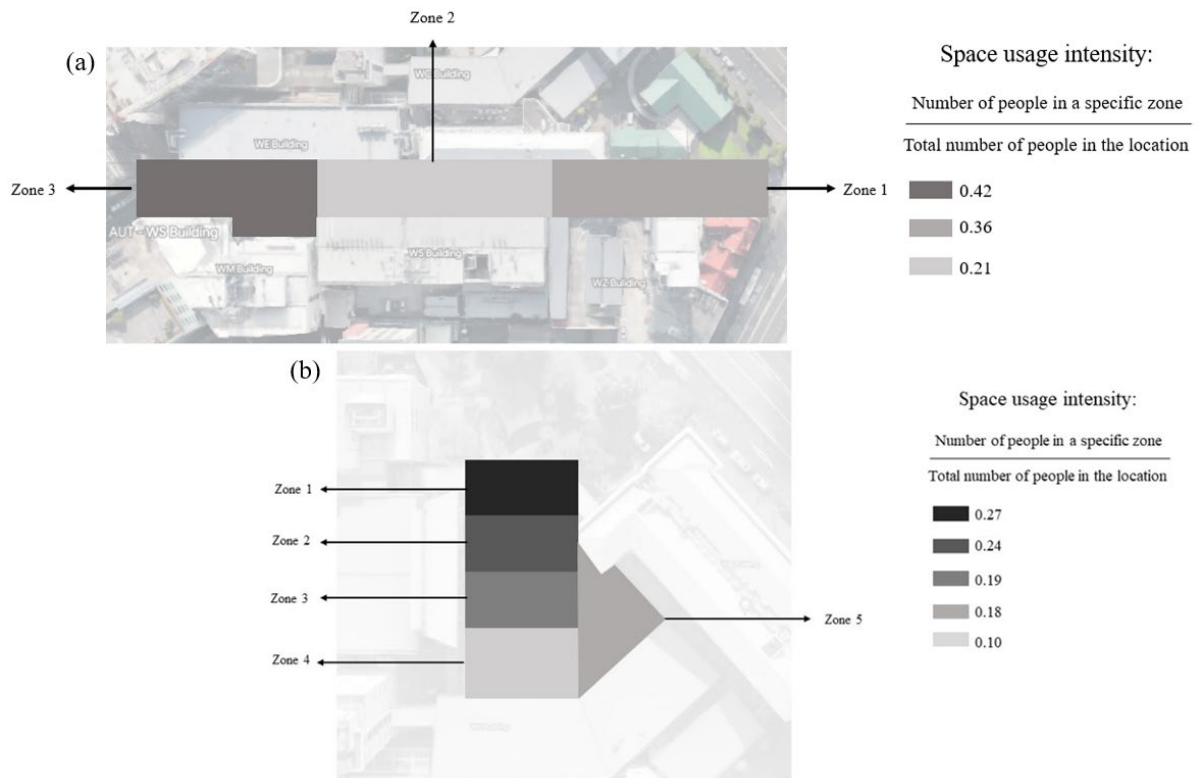

Figure 5.9 (a): Layer of exposure for location 1, (b): Layer of exposure for location 2

5.4.3 Preparing the layer of vulnerability

In this study, the risk determinant "vulnerability" is defined as the spatial distribution of user's adaptability capacity (Huang et al., 2018). To achieve this objective, we used questionnaires to obtain people's perceptions of different weather conditions based on participants genders, activities, the period they have been living in Auckland.

From 12:00 to 13:00 on 14th March 2023, as we did not define a specific number of participants, our approach involved randomly selecting individuals within the designated timeframe. We aimed to ensure a diverse representation by including individuals of both genders and various age groups. Consequently, we were able to conduct the study with 30 participants at location one. As depicted in Figure 5.10, the study consisted of 18 females and 12 males, with approximately half of the participants falling within the 16 to 25-year age range. Additionally, we displayed the participants' locations on the map. Among the participants, 13 reported feeling slightly warm, while 7 indicated feeling warm. Concerning humidity, nearly

95% of participants perceived it as natural. As for wind speed, 18 participants reported feeling windy; all questionnaires were filled out in unshaded areas. Subsequently, when analysing the questionnaire responses, we identified the locations where individuals reported experiencing discomfort, which in this study referred to feeling slightly warm, warm, and windy. By aggregating these discomfort points, we generated a vulnerability layer.

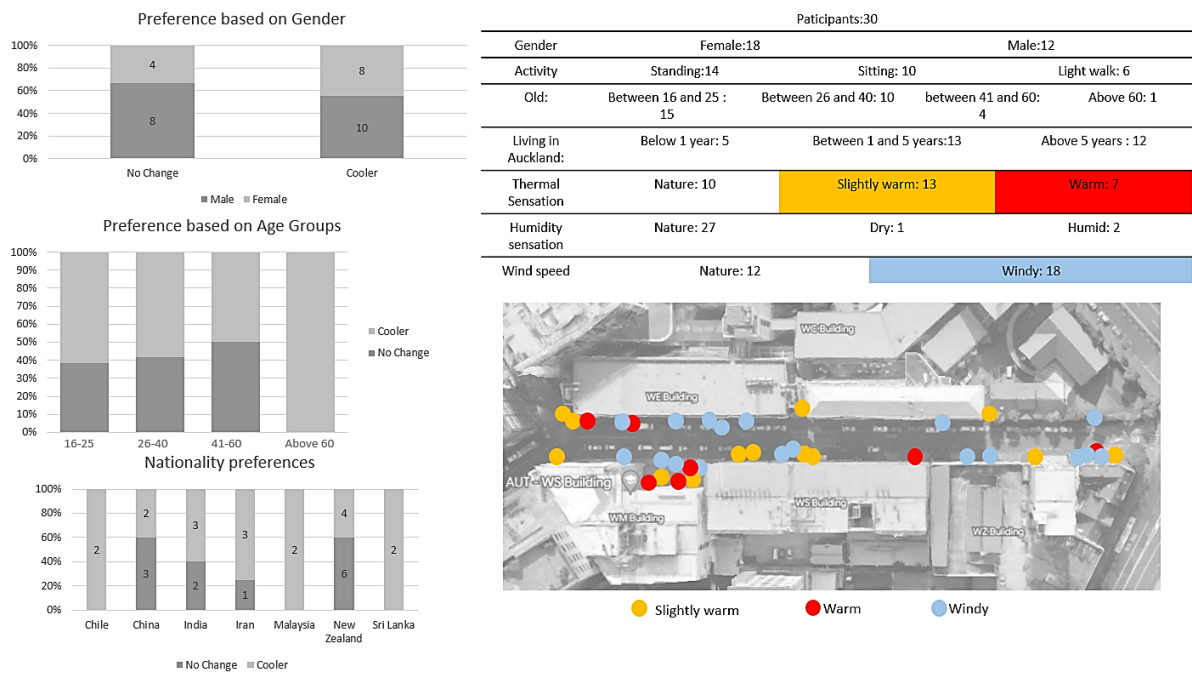

Figure 5.10. Layer of vulnerability for location 1

A similar approach was adopted for location two from 12:00 to 13:00 on 15th March 2023. In this case, we had 35 participants, including 17 females and 18 males. More than half of the participants fell within the 16 to 25-year age range. The questionnaire results indicated that 19 participants felt slightly warm, while 6 participants felt warm. Additionally, humidity was deemed acceptable by over 95% of the participants. Based on the questionnaire responses, 19 participants reported experiencing windy conditions; all questionnaires were filled out in unshaded areas. We marked the locations where people experienced discomfort on the map (Figure 5.11). Therefore, these identified discomfort areas were considered vulnerability zones for two locations when creating the vulnerability layers.

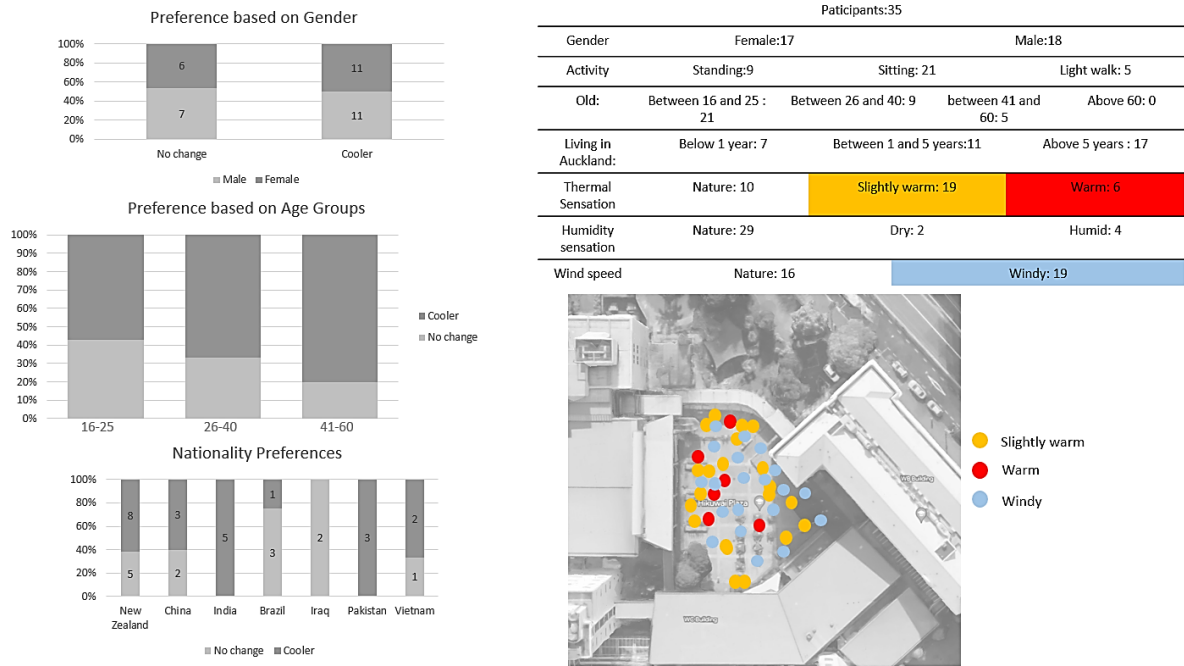

Figure 5.11 Layer of vulnerability for location 2

Relationship between Thermal Sensation and PET index (layer of hazard and layer of vulnerability)

In total, 167 questionnaire responses were gathered at location 1 on March 14, 2023, between 8:30 and 16:30. Additionally, 180 questionnaire responses were collected at location 2 on March 15, 2023, during the same time frame. Figure 5.12 illustrates a violin plot showcasing the distribution of PET indices across various thermal sensations reported by the participants. The central white dot within each violin signifies the average PET index value. Accompanying the violins are box plots that encompass the interquartile range (IQR), while the horizontal lines within the boxes denote the median values. The higher peaks in the outlines indicate a more frequent occurrence of PET indices associated with warm thermal sensations in both locations. Conversely, for respondent groups experiencing other thermal sensations, the peak distribution concentrates around lower PET indices. Notably, there is not a distinct peak distribution for the PET index related to slightly cool thermal sensations at location 1. Every violin plot offers insight into the mean, maximum, and minimum PET index values, as well as the 25%–75%

range of PET index distribution for different groups of respondents categorized by their thermal sensations. Specifically, at location 1, the mean PET index values are as follows: 19 for slightly cool, 21.88 for Neutral, 23.70 for slightly warm, and 24.52 for warm thermal sensations. In contrast, for location 2, the mean values are slightly elevated: 19.8 for slightly cool, 22.59 for Neutral, 23.77 for slightly warm, and 24.75 for warm thermal sensations.

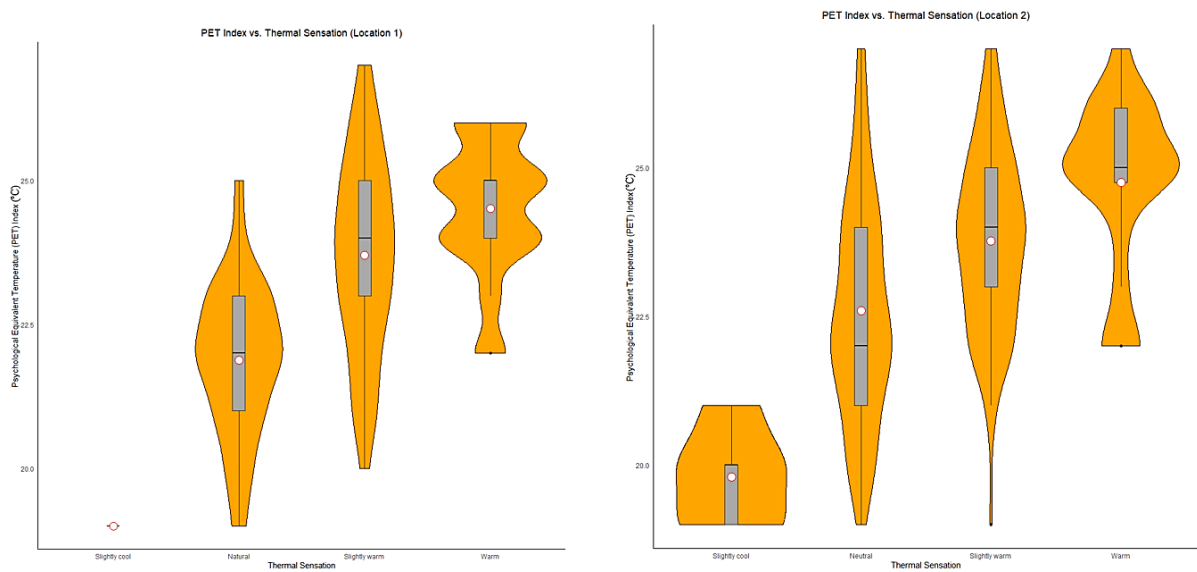

Figure 5.12 Distribution of PET index for outdoor thermal sensation votes

Bubble plots are used to explore the relationship between respondents' thermal sensation and the PET index at Location 1 and Location 2 (Figure 5.13). As can be seen, there is a strong linear relationship between the mean respondents' thermal sensation and the PET index.

Regression equations representing the mean respondents' thermal sensation as a function of the PET index were obtained and expressed as follows:

$$\text{(Location 1)} \quad \text{TSV} = 0.25 \text{ PET} - 5.04 \quad (\text{R}^2 = 0.85) \quad (\text{e.q.1})$$

$$\text{(Location 2)} \quad \text{TSV} = 0.18 \text{ PET} - 3.56 \quad (\text{R}^2 = 0.83) \quad (\text{e.q.2})$$

In terms of outdoor thermal comfort, the PET coefficient is 0.25 in location 1 and 0.18 in location 2, corresponding to an increase of TSV by 0.25 and 0.18 units, respectively, for each 1°C increase in PET value.

These equations (e.q.1 and e.q.2) can be used to calculate the Neutral PET (NPET). The NPET refers to the PET index that corresponds to the mean vote of neutral on the thermal sensation scale (TSV = 0), i.e., the PET index at which people feel neither cold nor warm. The NPET can be mathematically represented as $NPET = -c/m$, where 'c' is a constant, and 'm' is the slope. Using e.q.1 and e.q.2, we obtained NPET values of 19.96 °C at location 1 and 19.61°C at location 2. Notably, these results show a significant level of consistency. In Appendix C, an analysis of the relationship between thermal sensation and responses to questions has been provided.

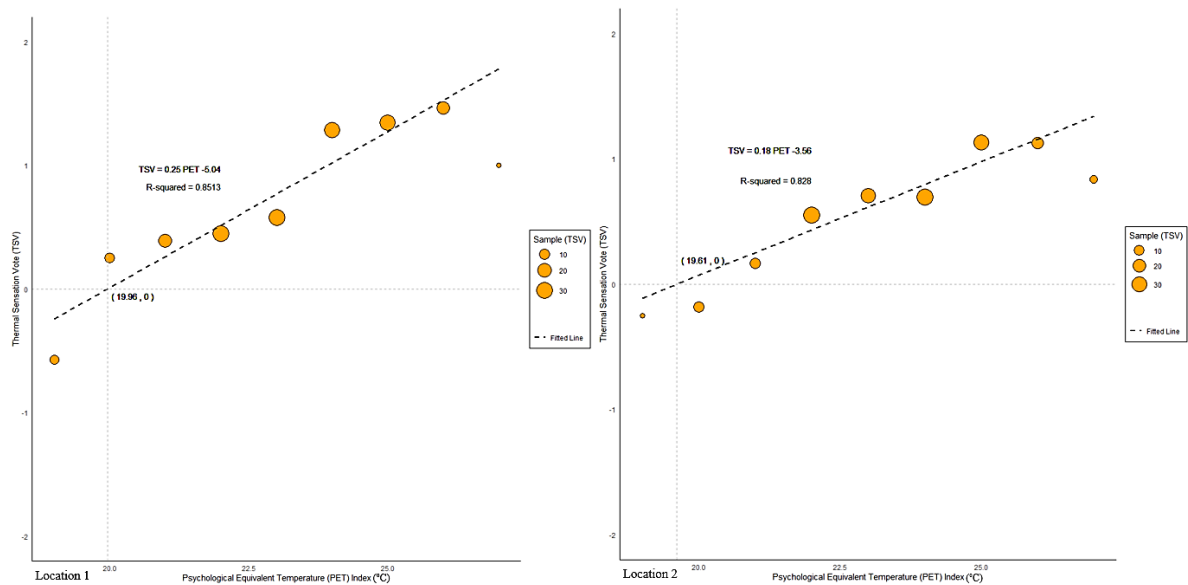

Figure 5.13 Bubble plot of the relationship between respondents' thermal sensation and the physiological Equivalent (PET) index (Note: For TSV scale, -3, -2, -1, 0, 1, 2, and 3 represent cold, cool, slightly cool, neutral, slightly warm, warm, hot respectively).

5.4.4 Identifying thermal risk areas

As outlined in section 5.3, the layers depicting the distribution of thermal stress, space usage intensity, and user vulnerability are combined through the superimposition process, utilizing the red-scale brightness levels from each layer map. This integration is visually presented in Figure 5.14 and Figure 5.15. In this representation, areas characterized by brighter red-scale indicate a lower level of risk, while regions with darker red-scale indicate a higher potential for thermal risk.

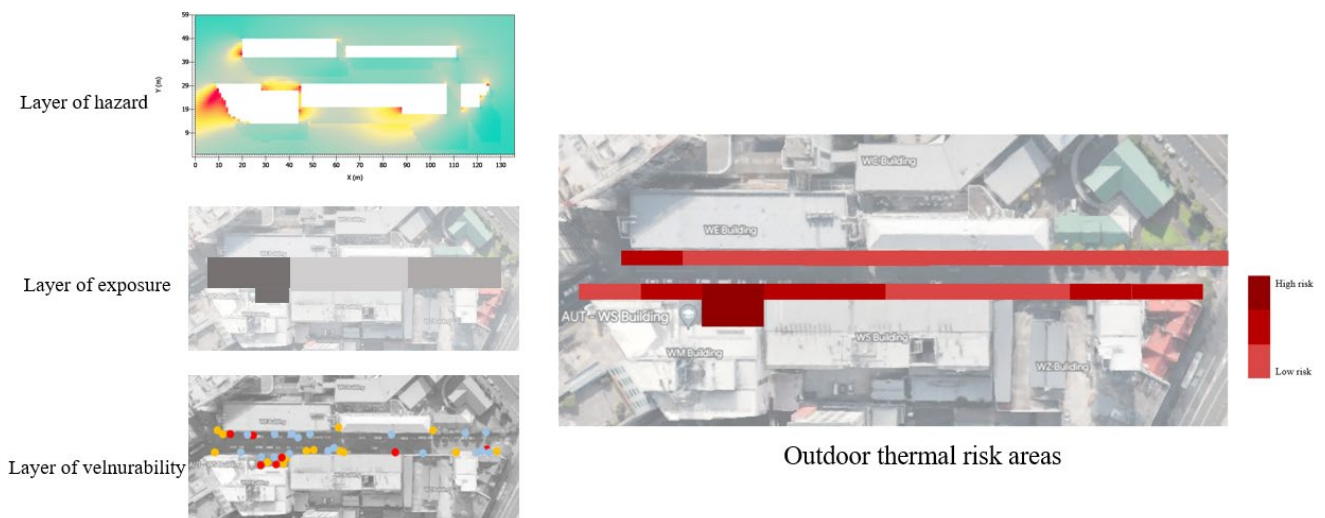

Figure 5.14 The construction of thermal risk map for location 1

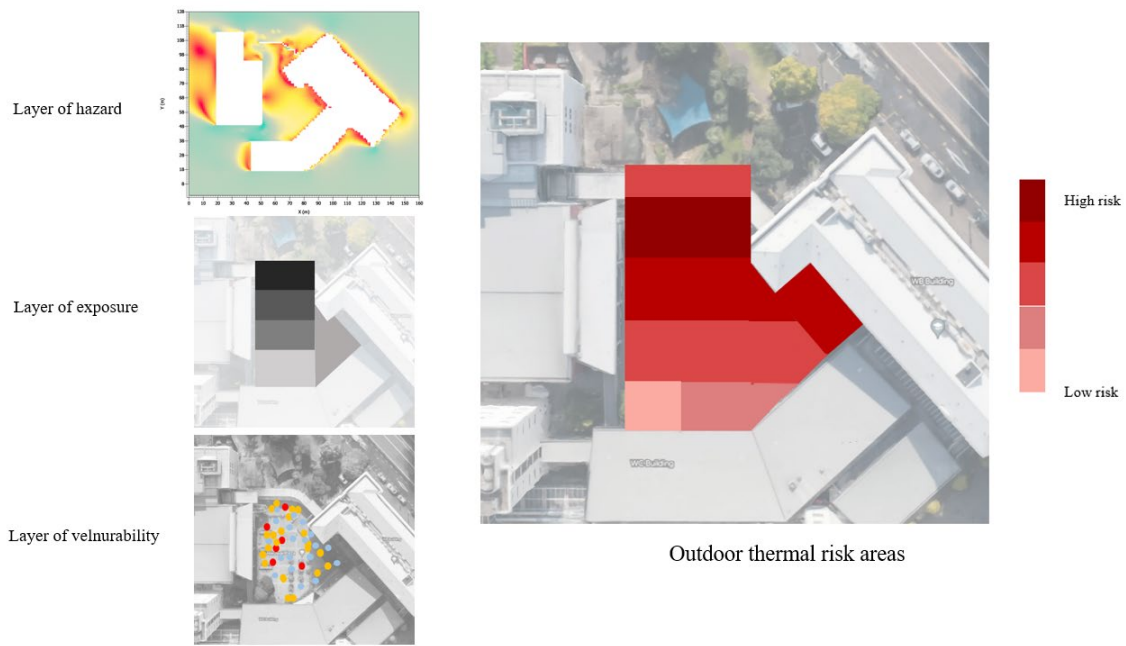

Figure 5.15. The construction of thermal risk map for location 2

5.4.5 Investigating future PET for years 2050 and 2080 at outdoor thermal risk areas

To obtain a preliminary understanding of future conditions in high thermal risk areas, as mentioned in the previous section, we assumed that these areas would continue to exhibit high exposure and high vulnerability. We then analysed the future trend of thermal comfort (the hazard layer), we conducted calculations to estimate PET levels for the summers of 2050 and 2080. To achieve this, we generated future climate scenarios using CCWorldWeatherGen. Based on the EPW weather files generated for summers 2050 and 2080 and by comparing the data with the EPW file of 2023, it is demonstrated that the average air temperature for March 2050 is projected to increase by approximately 0.5°C to 2°C, and for March 2080, the air temperature is expected to rise by approximately 1.7°C to 4.2°C.

The climate change projections and impacts for the Auckland region for RCP 8.5 are based on plans generated by the National Institute of Water and Atmospheric Research (NIWA). According to these projections, in summer 2050, the air temperature is predicted to increase by 0.75°C to 1.5°C, and by 2.5°C to 4°C in 2080.

By comparing the results of the generated air temperature in Summer 2050 and 2080 from CCWorldWeatherGen with the NIWA data, it can be concluded that the predicted air temperature using CCWorldWeatherGen is relatively accurate, with a difference of approximately 0.5°C compared to the NIWA data. Therefore, the generated data has been validated for our research, and we have utilized it as input weather data for simulating future PET in Envi-met.

The results, illustrating the differences in PET between the time periods, are presented in Figure 5.12 for location 1 and Figure 5.13 for location 2. Based on the simulations, we can conclude that in the future, people will face more thermal discomfort in thermal risk areas. To be more precise, the results from the Envi-met for location 1 indicate that the average PET in March 2023 is approximately 22.11°C. This is projected to increase to 24.39°C in 2050 and 26.45°C in 2080. Similarly, for location 2, the average PET for thermal risk areas in March 2023 is 23.92°C, which is expected to rise to 25.58°C in 2050 and 27.69°C in 2080.

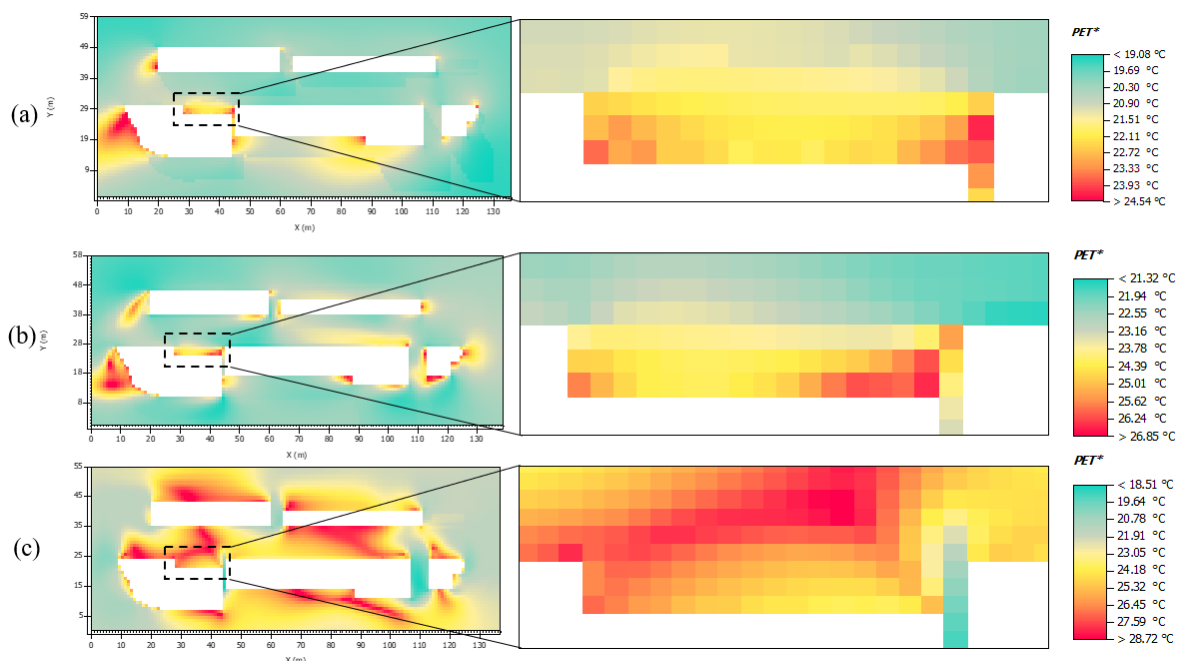

Figure 5.16 The PET levels and percentage for the areas with high outdoor thermal risk in location 1, depicting the years 2023(a), 2050(b), and 2080(c)

Based on Figure 5.16, the thermal risk area of location one in 2023 shows that PET exceeding 25°C constitutes only about 5% of the total area. However, this percentage is projected to increase to more than 60% in 2050 and 2080. To provide more specific details, by 2050, the thermal risk area will experience PET between 25°C and 27°C in approximately 50% of the spots. By 2080, PET exceeding 27°C will be observed in approximately half of the spots within the thermal risk area.

According to Figure 5.17, in 2023, approximately 30% of the thermal risk area in location 2 experiences PET exceeding 25°C. This percentage is projected to increase to 80% in 2050 and approximately 90% in 2080. By 2050, around 70% of the spots will experience PET between 25°C and 27°C, while in 2080, nearly 30% of the spots will face PET exceeding 27°C, and only 10% of the area will have PET between 23°C and 25°C.

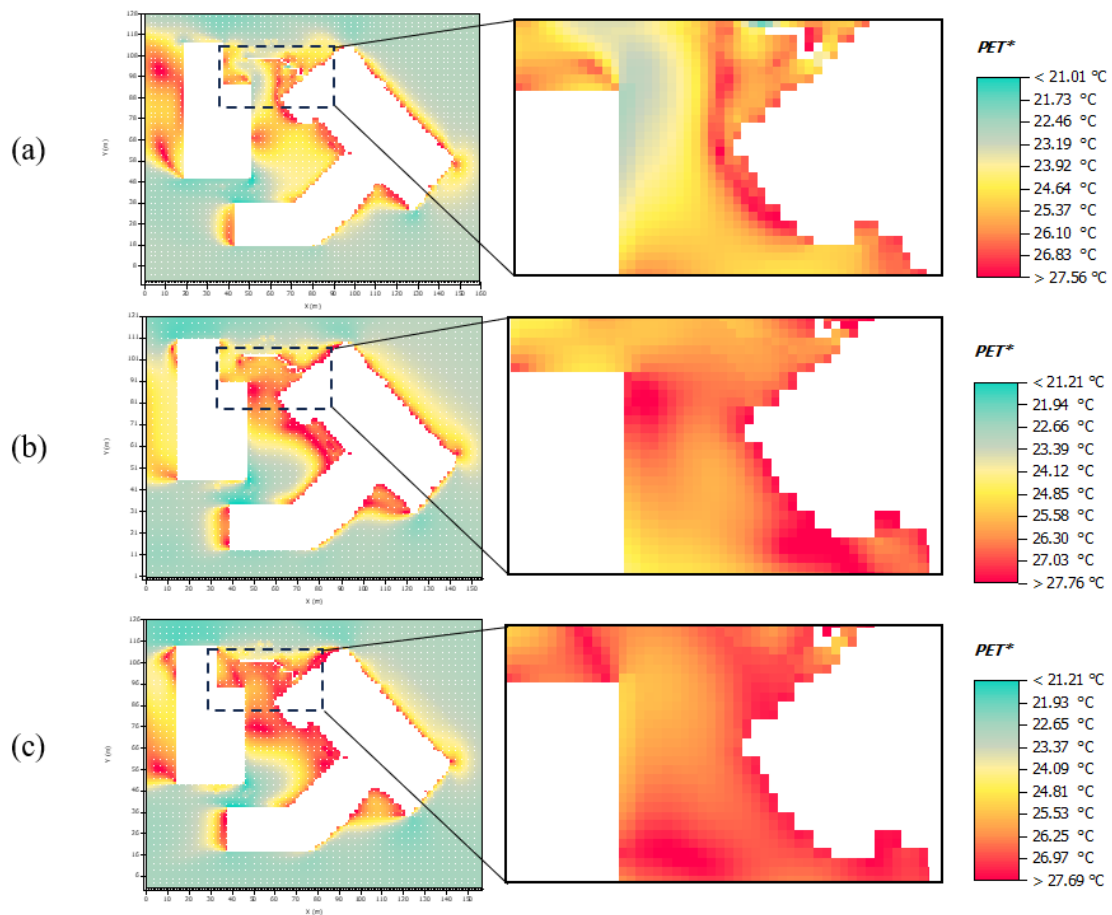

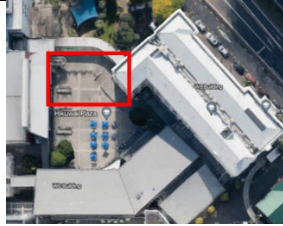



Figure 5.17 The PET levels and percentage for the areas with high outdoor thermal risk in location 2, depicting the years 2023(a), 2050(b), and 2080(c)

5.4.6 Results of new scenarios for reducing PET (hazard layer) in outdoor thermal risk areas

After identifying thermal risk areas and analysing the future thermal conditions in these areas, we attempted to define new scenarios for mitigating thermal stress (hazard layer). In the first stage, we thoroughly categorized the features of the thermal risk areas and sought the best approach based on the specific characteristics of each location to optimize the thermal conditions in those areas. The thermal risk area of Location 1 (St. Paul Street) pertains to the outdoor area of the Art and Design Building of AUT, while for Location 2 (Hikuwai Plaza), it refers to the central area of the plaza. All the features of the thermal risk areas are presented in Table 5.2.

Table 5.2 Features of thermal risk areas

	Outdoor thermal risk area of location 1	Outdoor thermal risk area of location 2
Aerial image		
Image		
Geometry features	This area has a rectangular shape and is in front of a 28-meter-high building. The width of the thermal risk area is approximately 14 meters, resulting in an aspect ratio of 2.	This area is situated between two buildings with heights of 24 and 16 meters, respectively. The thermal risk area has an approximate width of 25 meters, resulting in an aspect ratio of 0.8.
Material features	Building materials: Concrete, Steel, Glass Pavement materials: Light concrete, and asphalt	Building materials: Concrete, Steel, Glass Pavement materials: Light concrete
Greenery Features	There are four young trees and limited grass coverage in the area.	None

To establish future scenarios, an analysis was conducted on the conditions of outdoor thermal risk areas. At this stage, we decided to analyse the impacts of greenery on thermal risk areas, as the lack of sufficient green cover is evident in both thermal risk areas. Moreover, the preferences of the participants were considered through questionnaires, where more than half

of the 65 respondents (30 participants in location 1 and 35 participants in location 2) expressed their support for enhancing vegetation cover. Consequently, this approach was further investigated. Table 5.3 provides the locations and features of the selected scenarios.

Table 5.3 Features of future scenarios for high thermal risk areas

To address the high thermal risk in Location 1, it is proposed to replace the concrete wall of the building with green walls. The feature of the green wall is as follows:

- Green + mixed substrate
- Plant thickness: 0.30 m
- Substrate thickness: 0.15 m
- Greening properties:
- LAI [m^2, m^2]: 1.5
- Leaf angle distribution: 0.5
- Substrate properties:
- Emissivity: 0.95
- Albedo: 0.30
- Air gap between substrate and wall (m): 0.10



Six trees, positioned at 4 m from each other, were considered in the high thermal risk areas of location 2. The features of the trees are as follows:

- Foliage shortwave albedo: 0.18
- Foliage shortwave transmittance: 0.30
- Leaf emissivity: 0.96
- Crown top height: 3.5 m
- Leaf type: Coniferous
- Height: 5 m
- Width: 2.25 m

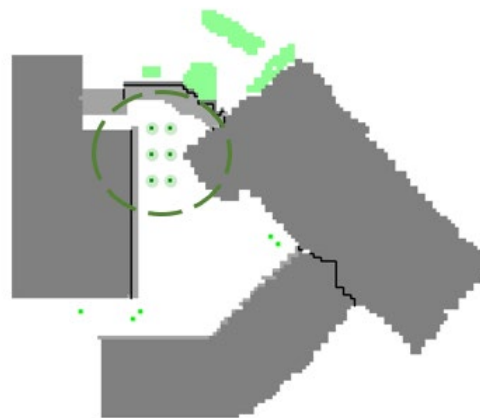

For the outdoor thermal risk area in location 1, the existing concrete wall of the building was replaced with a green wall. Regarding the outdoor thermal risk areas in location 2, the impact of tree planting was analysed. The outcomes of these new scenarios, measured in terms of PET, are presented in Figure 5.18 and Figure 5.19.

Figure 5.18 illustrates that the current average PET in the highest thermal risk area of location one is 22°C, which can be reduced to an average of 20°C by replacing the concrete wall with a green wall. In the case of location two, the current average PET in the highest thermal risk area is 25°C, and it can be decreased to 22°C through the implementation of tree planting (Figure 5.19).

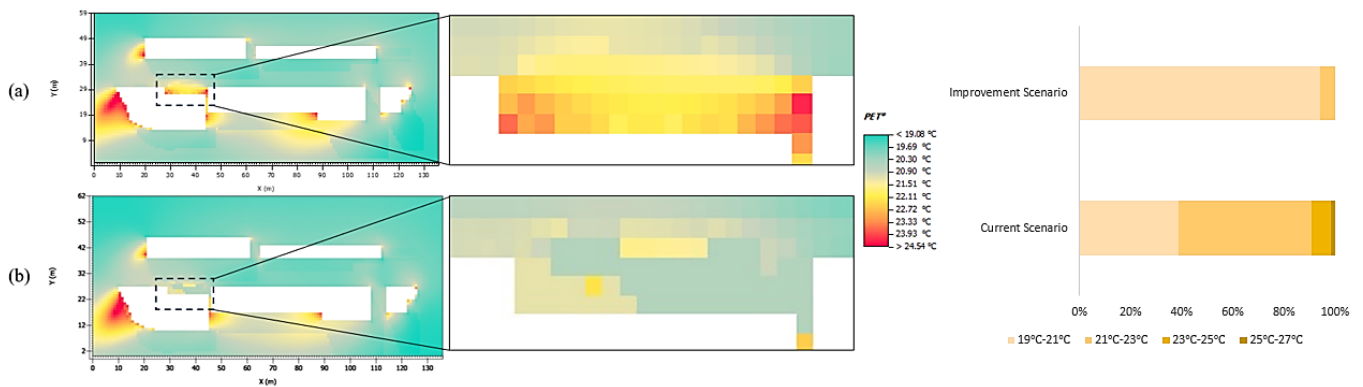

Figure 5.18 (a) PET levels of outdoor thermal risk area at location one under the current scenario. (b) PET levels of outdoor thermal risk area at location one under the defined scenario

Based on Figure 5.18, in the current situation of the thermal risk area in location one, nearly 10% of the area experiences PET exceeding 23°C. However, by replacing a concrete wall with a green wall, the percentage of the area with PET between 19°C and 21°C increases significantly to over 90%.

Regarding location 2, as shown in Figure 5.19, in the current scenario, around 80% of the spots within the thermal risk area experience PET exceeding 23°C. However, by planting trees, approximately 50% of the area will have PET levels below 23°C, and no spots will experience PET levels above 27°C.

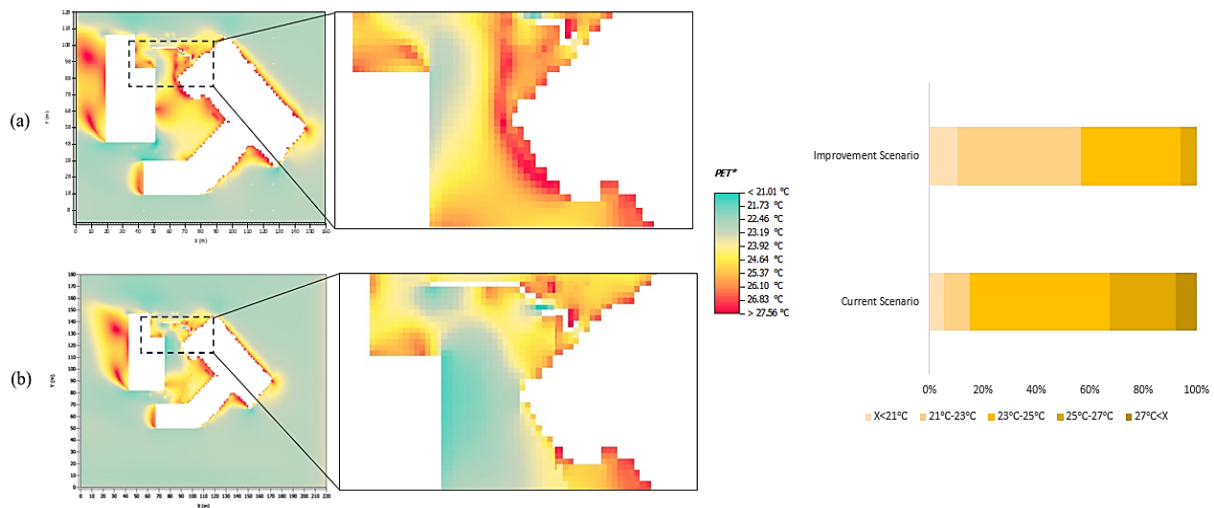

Figure 5.19 (a) PET levels of outdoor thermal risk area at location two under the current scenario. (b) PET levels of outdoor thermal risk area at location two under the defined scenario

Based on the observed changes in climate patterns and the results obtained in this study, which emphasize the projected increase in thermal stress (hazard layer) within thermal risk areas in future summers, as well as the positive impact of greenery in reducing current PET levels (hazard layer) in high-risk areas, we hypothesize that incorporating greenery in the identified thermal risk areas would be an effective approach for enhancing outdoor thermal comfort in the future as well.

5.5 Discussions and limitations of the study

While analysing outdoor thermal comfort has been a common focus in previous studies, limited research has specifically identified outdoor thermal risk areas. These areas result from the combination of high thermal stress and intense human presence. The significance of this

research becomes more apparent when considering the warnings of predicted climate change and global population growth. It is crucial to pinpoint the areas within cities that pose the highest risk due to both high thermal stress and human intensity. In greater detail, certain areas may experience high levels of outdoor thermal stress, but they are rarely utilized and do not warrant improvement. Thus, in this research, we aimed to identify outdoor thermal risk areas in Auckland university of Technology based on three different layers and specific methodologies for each layer, which can be applied in future studies for various locations.

Based on Auckland's current climate conditions, thermal stress does not emerge as a significant concern. The highest predicted PET level for selected locations under current conditions is approximately 25°C, indicating slight heat stress. However, these areas exhibit high exposure, with a significant number of people using them. Survey results indicate that more than half of the respondents felt slightly warm or warm in these locations.

To enhance the liveability of cities and encourage outdoor space usage, the focus should shift to areas with high exposure. New scenarios should be designed to provide as neutral a thermal condition as possible, even in areas not experiencing significant thermal stress at present. The importance of addressing high exposure areas with slight thermal stress becomes more apparent when considering predicted climate change and population growth. Simulation results for future climate conditions project an increase in thermal stress to nearly 28°C by 2080, accounting for population growth. This indicates a future with more severe thermal risk areas and higher exposure. Therefore, designing new scenarios for current thermal risk areas not only improves liveability in these locations but also works to control thermal stress in the future. These findings suggest that increasing green walls in high thermal risk areas can significantly reduce thermal discomfort, which is crucial for urban planners and architects designing climate-resilient cities.

However, it is important to acknowledge a limitation of this investigation, which lies in its narrow focus on a specific hour during a summer day to identify outdoor thermal risk areas within the selected location. Although we attempted to select days that represented the average weather conditions of Auckland based on historical data, choosing an hour that reflected the average highest temperature impacting thermal stress and the most populated time providing the highest exposure, for a more comprehensive result, we should expand the scope of our research to cover longer time periods. This expansion would allow us to evaluate thermal risks during different hours and in both hot and cold periods.

Furthermore, while the agreement between field measurements and Envi-met simulated data was satisfactory for air temperature and humidity, the normality of residuals was not as well-established for wind speed. The results of the questionnaires also revealed that high wind speed is as concerning as air temperature during summer, leading to discomfort in outdoor spaces. This aspect warrants further analysis of the wind speed factor in future studies. For example, comparing the results of simulating wind speed with other software simulations and defining scenarios for mitigating wind speed should be analysed in the future.

Furthermore, based on the results of the questionnaires, age group and nationality are significant predictors of thermal sensation. In future studies, we plan to enhance our data collection by involving a larger and more diverse group of participants. This will enable us to develop comprehensive exposure and vulnerability layers, providing a more thorough understanding of thermal risks.

Moreover, our focus on defining new scenarios has been centred around investigating the impact of greenery in mitigating outdoor thermal risks. This means that applying greenery in the thermal risk areas identified in this research can reduce thermal stress by a maximum of 3°C and create neutral thermal zones. However, our future research will explore a wider range

of scenarios, aiming to identify the most optimal approaches for mitigating thermal risks. It is crucial to emphasize that the current scenario presented in this research serves as a preliminary suggestion and should not be considered the definitive or ideal solution.

5.6 Conclusions

Due to urbanization and predicted climate change, the study of microclimate and outdoor thermal comfort has gained popularity in recent decades. However, New Zealand major cities like Auckland is relatively understudies. In this study, our method was to identify the thermal risk areas in the city campus of Auckland University of Technology. Our analysis focused on the period of 12:00 to 13:00 on the 14th and 15th of March 2023. Furthermore, we aimed to examine the future thermal patterns in these areas by simulating the Physiologically Equivalent Temperature (PET) for the summers of 2050 and 2080. Finally, we aimed to propose new scenarios for optimizing thermal stress in these areas. The research demonstrates that green infrastructure, such as green walls and increased vegetation, significantly improves outdoor thermal comfort in urban areas.

Based on the findings of our research, the following conclusions can be drawn:

- Under the current scenario and in the future, the identified thermal risk areas will experience higher thermal stress. The range of thermal stress in these areas is projected to increase by approximately 2°C in 2050 and 4°C in 2080.
- Considering the simulation results and predicted climate patterns, it is expected that Auckland will encounter an increase in the number of outdoor thermal risk areas during summers in the future.
- The simulation results indicate that greenery, specifically trees and green walls, have a significant impact in reducing PET levels in the identified thermal risk areas of

Auckland during summer. Future researchers can leverage greenery to enhance outdoor thermal comfort in the urban context of Auckland.

Our study highlights the importance of addressing outdoor thermal risks in urban areas, provides insights into the impact of climate change on thermal stress, and suggests the implementation of greenery as a potential solution to improve outdoor thermal comfort. The methods and findings presented in this study are expected to provide valuable insights for urban planners and architects in identifying thermal risk areas in various urban contexts and in implementing strategies to mitigate thermal stress. These efforts can contribute to improving the liveability of outdoor spaces in cities. Future research should explore the long-term impacts of green infrastructure on urban microclimates under different climate change scenarios.

Chapter 6 Pedestrian-level wind speed analysis: A case study at Auckland

University of Technology

6.1 Prelude

The findings from the analysis of different microclimate elements in Chapter 5 highlight wind speed as a particularly challenging factor requiring more detailed examination. Chapter 6 delves into the historical average wind speed in Auckland, employing Computational Fluid Dynamics (CFD) simulation models for Auckland University of Technology. To assess the range of wind speed and determine tolerable and unpleasant levels, a modified comfort criteria is designed, integrating questionnaire responses, the Beaufort scale, and CFD simulation results. High-risk areas are identified, and the impact of street orientations, aspect ratios, and building arrangements is analysed. The results underscore that street orientations have a more significant influence on wind speed than aspect ratios and building arrangements. Specifically, areas oriented at a 45-degree angle to the prevailing wind direction pose the greatest challenges, while reducing aspect ratios can mitigate wind speed in identified risk areas. The chapter aims to expand methodologies and insights, providing valuable knowledge for optimizing urban environments across diverse cultural and geographical contexts.

6.2 Introduction

In the process of urbanization, natural land covers give way to constructed materials, resulting in a substantial alteration of land surface roughness (Chew et al., 2017). The significance of urban morphology and architectural components on urban wind speed and thermal patterns cannot be denied (Banerjee et al., 2022). For example, the height-to-width ratio of a canyon, known as the canyon aspect ratio, stands out as a vital parameter when classifying wind speed within an urban street canyon (Rodríguez-Algeciras et al., 2018). The diversity in urban design elements, such as building arrangements and variations in street width, profoundly adjusts the

local ventilation capacity (Rodríguez-Algeciras et al., 2018). Alongside the larger-scale urban morphology factors, the small-scale details of the street also play a role in shaping urban wind speed (Ishugah et al., 2014). The flow dynamics within an urban area is mainly determined by factors like aspect ratio, building forms and orientations, street alignments, and the presence of vegetation (Xie et al., 2020, Huang et al., 2021).

In urban environments, wind speeds are lower compared to rural areas due to the obstruction caused by urban structures (Allegrini et al., 2015). While decreased wind speed can be beneficial in temperate climates during winter, the opposite holds true for tropical regions (Cheng et al., 2012). Both extremely high and low wind speeds at street level pose significant challenges to human comfort in urban areas (Gulyás et al., 2006). Hence, it is crucial to evaluate methods for analysing wind speed in urban street canyons. Many previous studies have focused on the impact of wind speed in tropical and subtropical climates, particularly its effects on outdoor comfort in these areas. For instance, research conducted in Singapore concluded that enhancing wind speed is the most effective strategy for improving comfort in shaded outdoor spaces (Yang et al., 2013). Similarly, a field survey carried out in Hong Kong found that individuals feeling warm wished for stronger winds, aligning with expectations (Li et al., 2018). The presence of stagnant air in urban areas has led to outdoor thermal comfort issues during the hot and humid summer months in Hong Kong, among other challenges (Ng et al., 2011). In the temperate climate, a study in an inner-city neighbourhood (Oberhausen, Germany) showed that increasing wind speed in summer can reduce Physiological Equivalent Temperature (PET) by up to 1.5°C (Müller et al., 2014). Research in the Netherlands also shows that urban geometry has significant impacts on wind speed (Taleghani et al., 2015).

For increasing liveability in urban contexts, providing an acceptable range of wind speed is necessary. For this aim, it is necessary to define a specific comfort wind range based on the location. This helps architects and urban designers assess the wind speed in designated areas

and create outdoor areas as comfortable as possible, encouraging people to spend more time outdoors. In this research, a specific wind comfort criteria have been designed to analyse the results of simulated wind speed in selected locations based on the comfort range, serving as a guide for new design scenarios. After identifying areas at risk due to high wind speeds, we then analyse the impact of urban design elements, such as street orientation, aspect ratio, and building arrangements, on these conditions. These elements play a significant role in wind speed in various urban contexts. After analysing the impacts of these elements on wind speed at the selected location of this research, we compare these research results to the previous literature review in Section 8 (moving beyond the local context) to obtain a broader perspective on the impacts of different urban elements on wind speed in various climates.

New Zealand is in the latitudes known as the 'Roaring Forties,' which means it experiences relatively high average wind speeds. Auckland City, the largest city in New Zealand, is situated in a relatively windy area. Auckland is often referred to as the 'City of Sails (Flay & Locke, 2019). Based on Auckland, New Zealand's weather history, the average wind speed from 2000 to 2022 was 4.64 m/s. Additionally, the highest wind speed during these 22 years was recorded in October 2009, reaching a speed of 58.12 m/s (Figure 6.1).

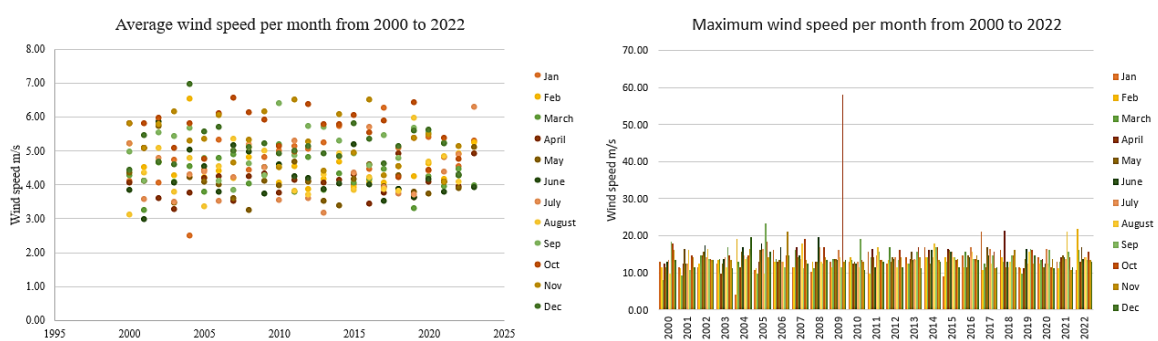

Figure 6.1 Wind speed pattern of Auckland New Zealand from 2000 to 2022 per month

(source: <https://www.wunderground.com/history/daily/nz/auckland>)

New Zealand has recognized the challenges associated with unpleasant or dangerous wind conditions particularly in cities (Flay & Locke, 2019). Auckland Council has established wind

comfort criteria in its Unitary Plan Operative. These criteria are divided into four comfort categories for different types of activities, as well as a dangerous level. The four comfort categories roughly correspond to activities involving prolonged sitting, brief sitting, slow walking, and fast walking. Generally, areas designated for long-term public use (Category A) have lower wind speed limits compared to areas intended for passage (Category D). Category E is considered dangerous and undesirable for any location. These wind categories are based on the probability of exceeding specific hourly mean wind speeds. To be classified as Category A, the area's hourly mean wind speed must be less than 4.3 m/s for 99% of the time. In contrast, to be classified as Category D, the hourly mean wind speed needs to be less than 10.3 m/s for 99% of the time. This means that Category D areas can experience mean wind speeds more than twice as strong as Category A areas while still meeting the established criteria (Flay & Locke, 2019).

Many research studies conducted in Auckland have used wind performance categories to evaluate the impacts of buildings, especially high-rise buildings, on the wind speed in their surrounding areas through wind tunnel tests (Flay & Andrews, 1995, Richards et al., 2002, Flay & Locke, 2019, Pirooz et al., 2020, Li, 2022). They utilized the wind comfort criteria set by Auckland Council, which defined an hourly mean wind speed of under 4.3 m/s as suitable for long-term public use as a reference for their analysis. However, significant research gaps in wind comfort criteria at the pedestrian level in Auckland still need addressing.

1. While there is some prior research on wind speed analysis at the pedestrian level in Auckland, the number of studies is limited. Most of these studies have focused solely on analysing the impact of building heights on wind speed. Neglected aspects such as the canyon aspect ratio, building arrangements, and building directions play a vital role in wind speed analysis at the pedestrian level and need to be addressed.

2. Wind tunnel analysis involves the use of physical facilities to test real airflow over physical models. In contrast, Computational Fluid Dynamics (CFD) simulations utilize computer algorithms to solve fluid dynamics equations, simulating fluid flow and its effects without relying on physical models. CFD simulations offer flexibility, enabling the study of flows at various scales, from macro to micro. They allow for easy parameter adjustments, condition changes, and analysis of multiple scenarios without the need for new physical models. CFD simulations are efficient for iterative design and rapid scenario evaluation. Therefore, it is essential to use CFD simulations alongside wind tunnel testing to analyse wind speeds in Auckland.

3. While the Auckland City Council has recommended a mean wind speed of under 4.3 m/s as a comfortable range for long-term public use based on the Beaufort scale (Bennett, 2007), it is necessary to reconsider and modify this range. As indicated in Table 6.1, when wind speeds exceed 3.3 m/s, categorized as a gentle breeze, based on comfort criteria and safety, long-term sitting and standing become tolerable just once a week (Bennett, 2007). Therefore, it is crucial to establish a more precise range of wind speeds for analysing pedestrian comfort in Auckland.

Table 6.1 Beaufort scale (Bennett, 2007)

Beaufort scale	Description	Mean wind speed range (m/s) @ 10m	Effects
B0	Calm	0-0.2	
B1	Light Air	0.3-1.5	No noticeable wind.
B2	Light Breeze	1.6-3.3	Wind felt on face.
B3	Gentle Breeze	3.4-5.4	Wind extends light flag.
B4	Moderate Breeze	5.5-7.9	Raises dust and loose paper. Hair disarranged and clothing flaps.
B5	Fresh Breeze	8.0-10.7	Limit of agreeable wind on land.

B6	Strong Breeze	10.8-13.8	Umbrellas used with difficulty. Force of the wind felt on the body. Wind noisy and frequent blinking.
B7	Near Gale	13.9-17.1	Inconvenience felt when walking, difficult to walk steady. Hair blown straight.
B8	Gale	17.2-20.7	Generally, impedes pedestrians, walking difficult to control. Huge difficulty with balance in gusts.
B9	Strong Gale	20.8-24.4	People blown over by gusts. Impossible to face wind, ear ache, headache, breathing difficulty. Some structure damage occurs, failing of roof tiles, tree branches etc. Very hazardous for pedestrians.
B10	Storm	24.5<	Seldom experienced inland. Trees uprooted, considerable structural damage occurs.

In this study, our objective is to analyse wind speeds based on different aspect ratios, building arrangements, and building directions in an urban area located within Auckland. The focal point of our investigation is the city campus of Auckland University of Technology. Aligned with our concerns, the primary aims of this study are as follows:

1. Evaluating public sensations of wind speeds during both summer and winter.
2. Utilizing CFD to simulate wind speeds based on historical data and analyse the impacts of street orientations, building arrangements, and various aspect ratios on wind speed.
3. Altering aspect ratios for mitigation strategies in areas identified as high risk.

In this research, our goal was to extend methodologies and insights, providing applicable knowledge for optimizing urban environments across diverse cultural and geographical settings. From an architectural and design perspective, we analyse the impacts of aspect ratios, various orientations, and building arrangements on end users' comfort and perception, with the intention of incorporating these findings into future architectural and urban design processes.

6.3 Method

This research comprises three distinct phases. In the first phase, we administered surveys to a diverse set of participants during both the summer and winter seasons, aiming to find out their sensations of wind speed in specific locations. We also recorded pertinent physical attributes such as age, gender, clothing type, and activity level. Moving to the second phase, we simulated wind speeds by CFD (Ansys Fluent) at the selected locations using historical wind speed data from 2000 to 2022. Proceeding to the third phase, with wind speed simulations finalized, we pinpointed areas with high wind speeds and endeavoured to formulate mitigation strategy scenarios for these locations. These new scenarios encompass adjustments to the new aspect ratios (Figure 6.2).

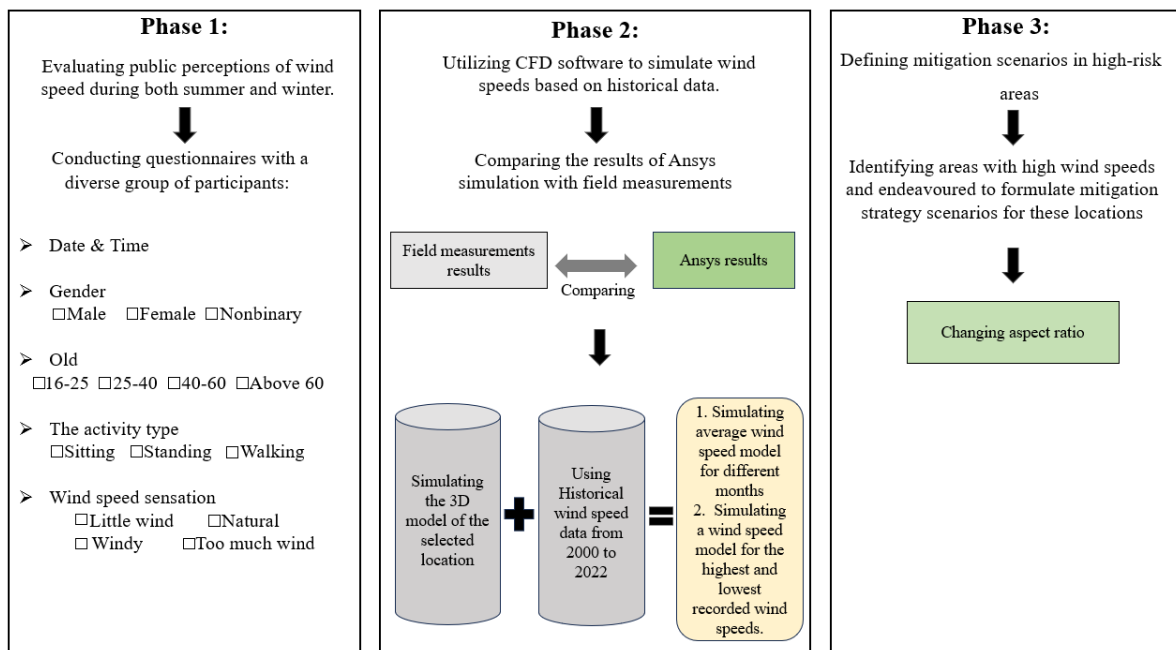

Figure 6.2 The structure of the research

The research is conducted at the city campus of Auckland University of Technology (AUT), located at S-36° 51', E174° 46', with an approximate area of 38,000 m². The study area comprises 16 buildings ranging in height from 8 to 48 m. The orientations of these buildings vary, ranging from north-south and west-east to northwest-southeast and northeast-southwest,

exhibiting diverse aspect ratios from shallow to deep. Vegetation cover, particularly trees, is sparse in the southern part of the location but becomes more abundant in the northern part (Figure 6.3).

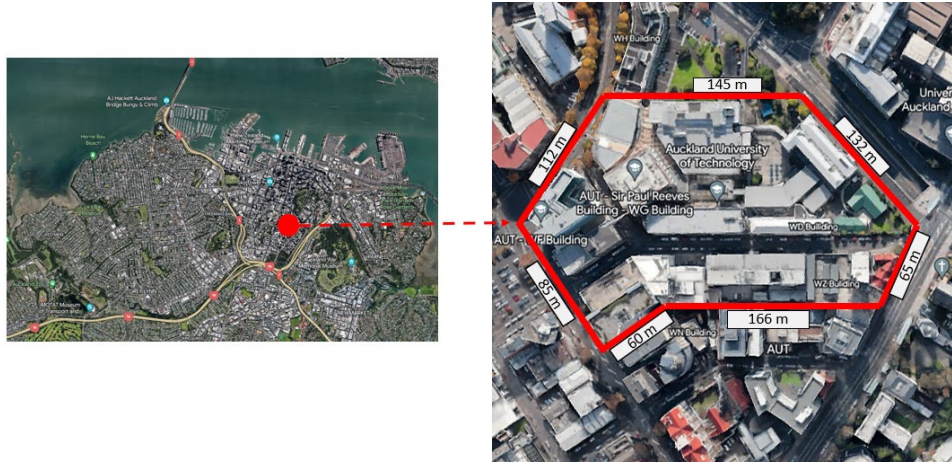

Figure 6.3 Research location

6.4 Evaluating public sensations of wind speed (Phase 1)

Wind speed at the pedestrian level is among the most critical environmental factors that influence user satisfaction in urban open spaces. Individuals have diverse sensations of wind speed, resulting in variations in their resilience and vulnerability. Before assessing the wind speed range based on software simulations and designed comfort criteria, our aim was to understand people's actual wind sensations at various times in selected locations. This approach gives architects and urban designers a more realistic sense for design by assessing real people's feelings in the initial stages of design. To assess people's sensations of wind speed, surveys were utilized. These surveys were conducted on various days during the summer and winter of 2023, between 8 am and 4 pm, at different locations within AUT. We aimed to administer questionnaires in all four main outdoor areas, which serve as primary gathering spots and leisure spaces. Due to resource limitations, collecting data from every individual present at these locations was not feasible. However, efforts were made to distribute surveys to as many participants as possible. To ensure a representative sample, participants of different genders

and ages were deliberately selected. The surveys included inquiries about participants' preferences concerning wind speed. Furthermore, relevant physical attributes, including age, gender, clothing type, and activity level, were recorded.

As a result, the study successfully included 706 participants—342 females and 364 males (Figure 6.4-a). Over half of the participants, namely 60%, reported feeling windy or experiencing excessive wind during both summer and winter seasons. To be more precise, during winter, 56% of all participants (94 females and 109 males out of 347 participants) reported feeling windy or experiencing too much wind. This percentage increased to 63% during the summer, with 117 females and 104 males out of 359 participants reporting the same sensation. Notably, the feeling of excessive wind was more prevalent among females, surpassing males by 61% compared to 58% (Figure 6.4-b). These findings can be emphasized by previous studies, which indicate that women are more weather-sensitive than men (Graw et al., 2022, Zafarmandi et al., 2022, Zafarmandi et al., 2023).

In terms of age distribution, half of the participants fell between the ages of 26 and 40. The highest frequency of perceiving strong winds was among participants above 60 years old, constituting 71% of this group. This was followed by participants aged between 16 and 25, with 58% reporting a similar sensation (Figure 6.4-c).

The results of the questionnaires indicated that wind speed causes discomfort for a significant number of participants, who are considered a sample of end users utilizing outdoor spaces at Auckland University of Technology. This suggests the need for analysing wind conditions and their impacts on people's comfort in more detail.

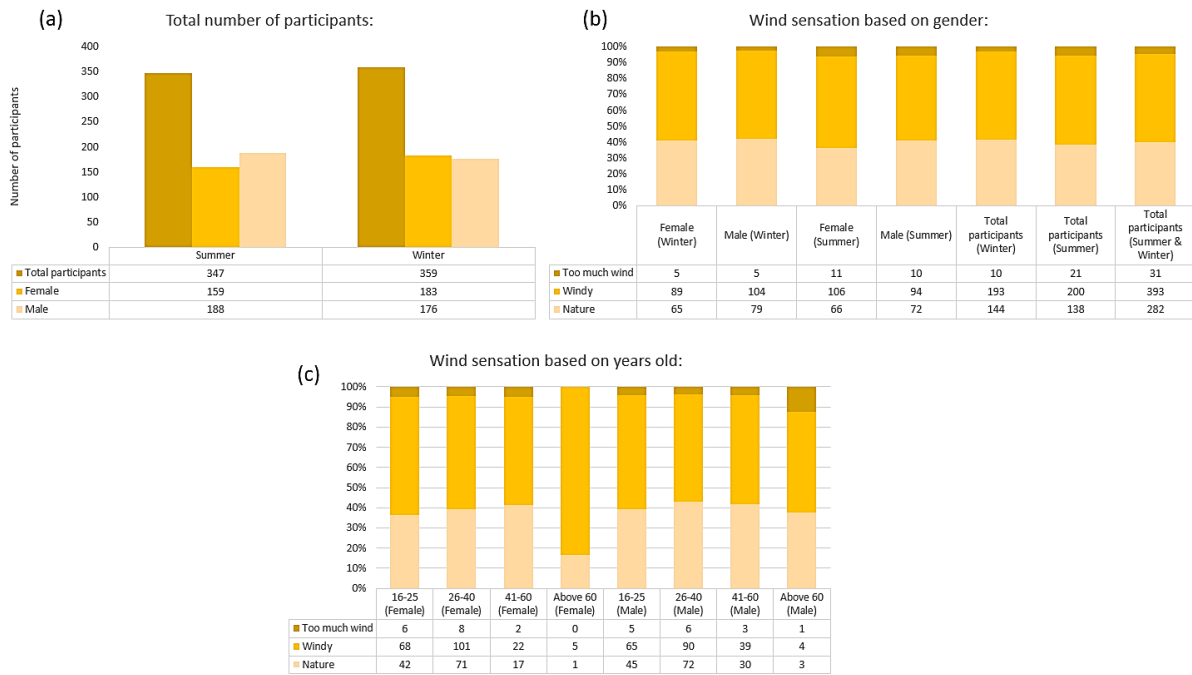

Figure 6.4 Wind sensation based on surveys

6.5 Utilizing CFD to simulate wind speeds based on historical data (Phase 2)

In this study, we chose Ansys Fluent as our Computational Fluid Dynamics (CFD) simulation tool. CFD models offer an effective and potent approach to estimating wind speed in urban settings (Blocken, 2015). They are crucial for comprehending and optimizing wind conditions in the design and development of urban places due to their adaptability, affordability, and capacity to handle complex scenarios (Mirzaei, 2021). Ansys Fluent is a computational fluid dynamics (CFD) software suitable for modelling various fluid flow phenomena, including wind speed in urban areas (Mirzaei & Carmeliet, 2013). In ANSYS, a high-quality mesh is crucial for accurate simulations, allowing the capture of urban area details. The boundary conditions for simulation encompass specifying inflow conditions (wind speed, direction, turbulence properties), where turbulence significantly affects urban airflow (Pantusheva et al., 2022). In our research, the RANS model was utilized, specifically the shear stress transport model based on $k-\omega$ equations, which is a well-established computational fluid dynamics tool for simulating single-phase flows with high Reynolds numbers. This model was chosen due to its high

accuracy near walls and its superior convergence compared to other models. It employs the Navier-Stokes Equations for momentum conservation and the continuity equation for mass conservation. Turbulent flow effects are incorporated through the modified Wilcox $k-\omega$ two-equation model, which accounts for realistic limitations in the equations used (Younis & Berger, 2004).

The validity of the simulated wind data was evaluated by comparing observed meteorological values. Field measurements were conducted using the Davis 6152 Wireless Vantage Pro2 weather stations. The Vantage Pro2 employs high-quality sensors designed to provide accurate and reliable measurements of wind speed and direction. The sensors utilized in the Vantage Pro2 maintain an accuracy of within ± 2.2 km/h for wind speed. Four distinct locations were selected for field measurements based on their potential to provide varying degrees of shade. The sensors were positioned at pedestrian level with a height of 1.5 m during the measurement process. Meteorological conditions at these locations were monitored and recorded every 30 minutes from 8:30 to 16:30 on March 14, 2023 (Figure 6.5).

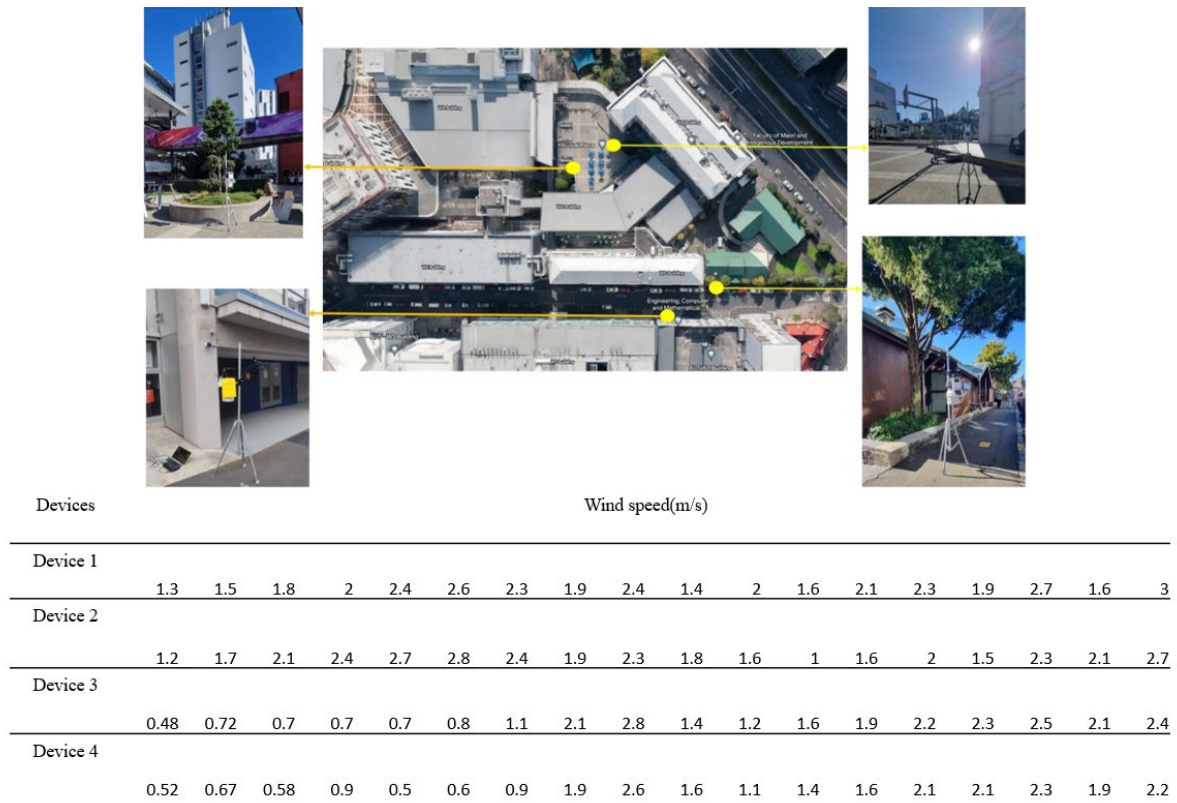

Figure 6.5 The locations of Davis 6152 wireless vantage pro2 weather stations

Subsequently, the wind speed results obtained from field measurements were compared with the corresponding data simulated by ANSYS Fluent software for a specific day in March 2023. To be more precise, weather stations recorded wind speed every 30 minutes at selected locations, totalling 18 wind speed measurements for each location. Afterward, we simulated the wind speed at these selected locations using ANSYS Fluent software with 18 different wind speeds. The inlet wind speed and direction were obtained from the Auckland climate and weather website for the specific day and time. As depicted in Figure 6.6, we used the recorded wind speed from the meteorological data of Auckland as the inlet. Additionally, turbulence properties were set based on previous research (Shu et al., 2020). In this study, the distance between the study area and the domain boundary is determined by previous research. Specifically, considering the highest building height as 48m ($H=48$), the upstream distance is set to $5H$, the downstream distance to $15H$, and the lateral distance to $\pm 5H$ (Janssen et al., 2013,

Abu-Zidan et al., 2021). The details of the CFD simulation are illustrated in Fig. 6, with the total number of mesh elements set at 7260609. A sensitivity analysis, involving the mesh density of the computational domain, was performed to investigate its impact on solution accuracy and convergence (Montazeri & Blocken, 2013, Gilani et al., 2016). Initially, the CFD analysis was run with a coarse mesh (2052649 number of mesh elements). Then, to determine the optimal mesh resolution, the number of mesh elements was increased to 7260609, which yielded the highest accuracy in the CFD results.

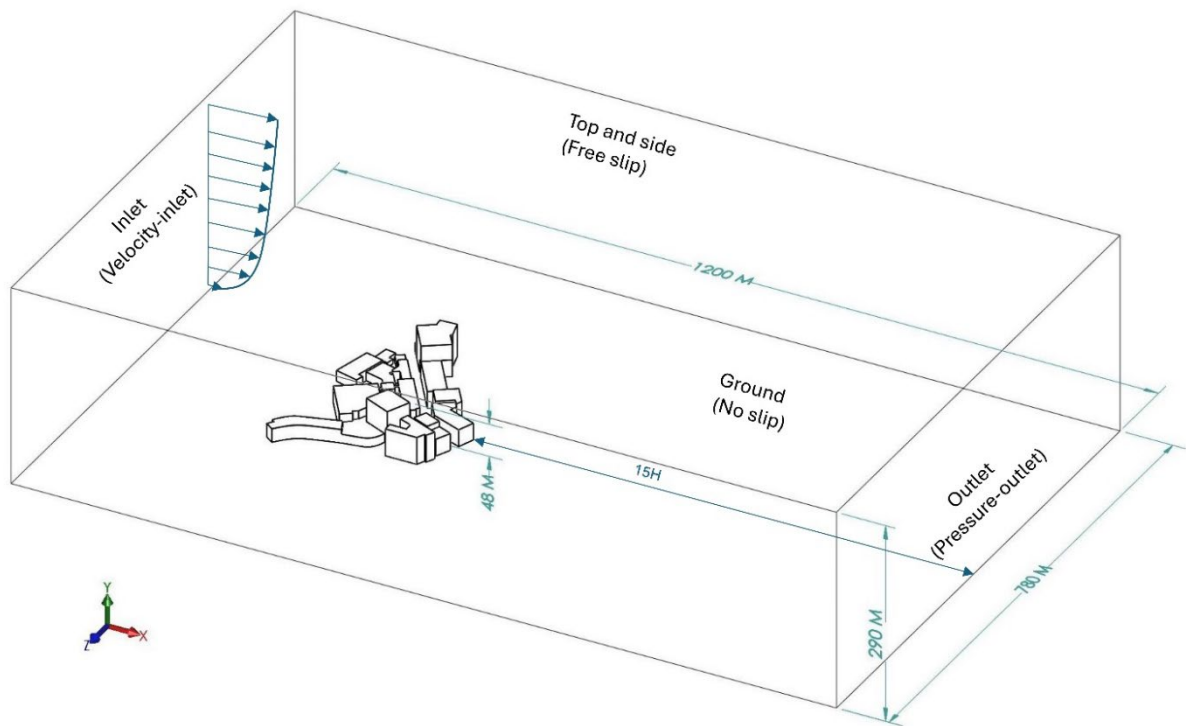

Figure 6.6 Details of the CFD simulations, (number of mesh elements: 7260609)

6.5.1 Agreement between Field Measurements with CFD Simulation Data

R^2 is commonly used as a method to assess the agreement between measured data and simulated data (Heinzl & Mittlböck, 2003). In this research, the R^2 metric was employed to assess the concordance between field measurements and the simulated data produced by Ansys for wind

speed. The obtained R-squared values exceeded 0.99 for all four measurements, indicating a robust alignment between the measured and simulated data (Figure 6.7).

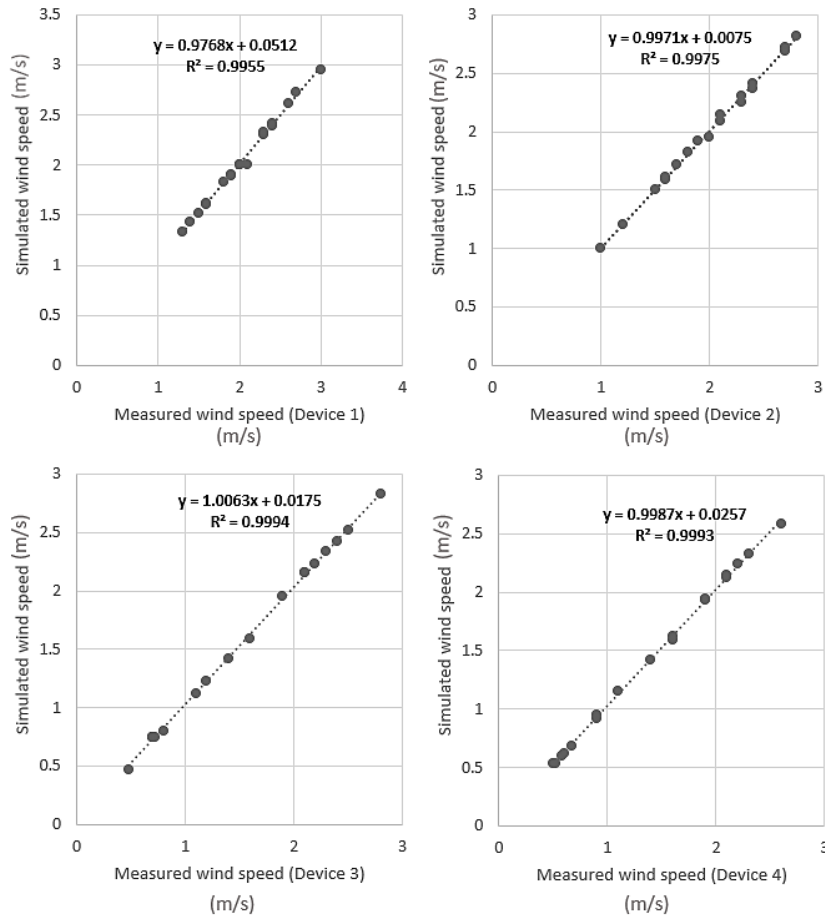

Figure 6.7 scatter plot illustrating the measured and CFD simulated data points

After comparing the results of field measurements using CFD simulation, we concluded that the simulation offers great accuracy in simulating wind speeds at the chosen location. Consequently, we utilized Ansys to simulate historical wind speeds in AUT for four distinct periods at the height of 1.80 m, to analyse the effects of wind speed on people's comfort, the average wind speed during Summer, Spring, Fall, and Winter from 2000 to 2022 were simulated. The simulation results are presented in Table 6.2. The average wind speed and directions, serving as the inlet information for the simulations, are provided in the following table. Turbulence properties were based on previous research (Shu et al., 2020). Due to the

limited number of young trees located away from the main areas, they were just represented as simple shapes with real height and width in the simulations.

Table 6.2 The results of CFD simulation

The average wind speed in Summer from 2000 to 2022:

Average Wind Speed: 4.82 m/s, Wind Direction: North-east

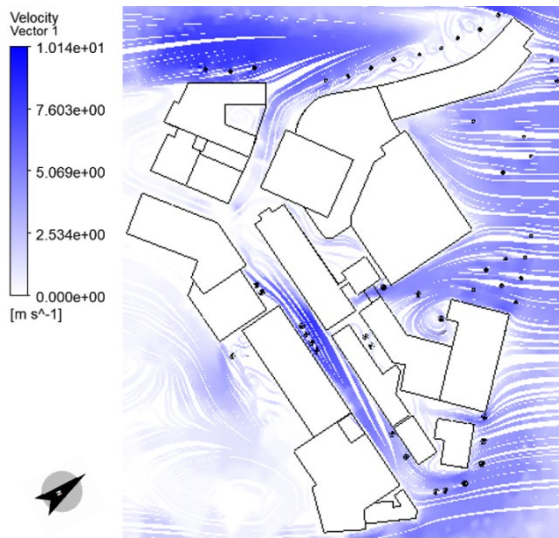

The average wind speed in Fall from 2000 to 2022:

Average Wind Speed: 4.11 m/s, Wind Direction: South-West

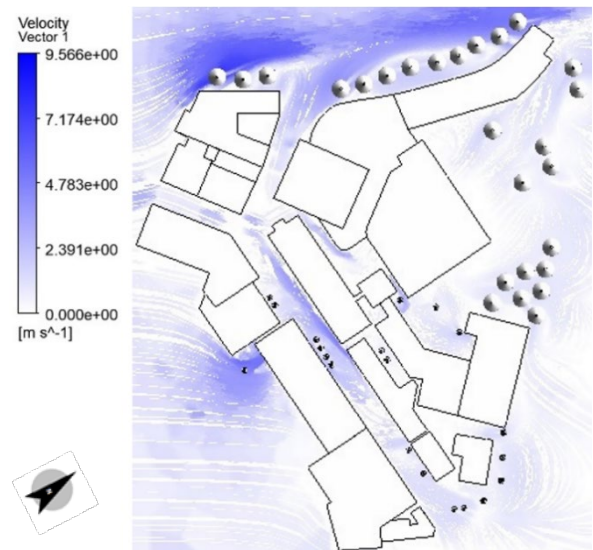

The average wind speed in Winter from 2000 to 2022:

Average Wind Speed: 4.31 m/s, Wind Direction: South-West

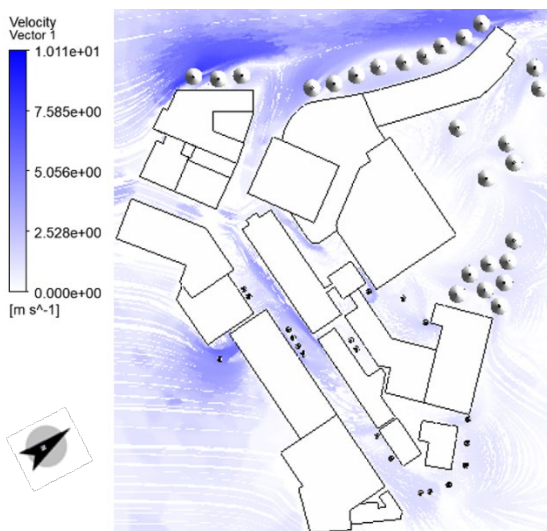

The average wind speed in Spring from 2000 to 2022:

Average Wind Speed: 5.31 m/s, Wind Direction: South-West

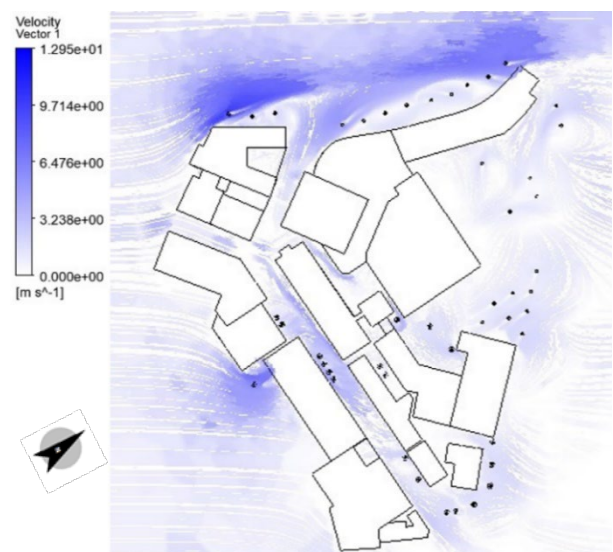

After simulating wind speeds based on historical data for four different seasons, we need to establish comfort criteria to analyse the effects of wind on people's comfort in selected locations and identify high-risk locations with high wind speeds. As explained in the introduction, the Auckland Council has a wind comfort criterion that requires modification and a more accurate range based on other scales such as the Beaufort Scale. This range was developed by combining wind comfort criteria from the Auckland Council with the Beaufort Scale. According to the modified comfort criteria, areas with an average wind speed between 1.6 m/s and 3.3 m/s are considered tolerable, areas with an average wind speed between 3.4 m/s and 5.4 m/s are moderately unpleasant, and areas with an average wind speed between 5.5 m/s and 7.9 m/s are significantly unpleasant (Figure 6.8).

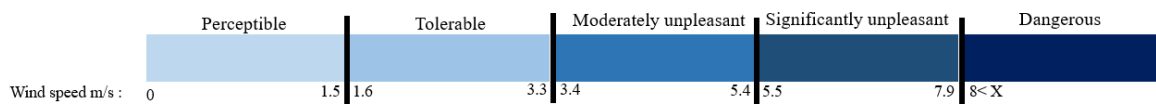

Figure 6.8 Modified comfort criteria based on wind speed

Furthermore, to delve into wind speed details and identify potential risk areas, we subdivided the AUT campus into 4 distinct outdoor zones, which are the principal outdoor areas at AUT (Figure 6.9). We conducted an analysis of the wind patterns within these areas and utilizing the Ansys results. We consider the direction and aspect ratio of each location, which is the ratio between the average height (H) of the canyon and the width (W) of the canyon itself (Oke, 1988, Ali-Toudert & Mayer, 2006, Gromke & Ruck, 2012). A canyon is considered uniform when its aspect ratio is approximately equal to 1 (with no noticeable openings on the walls), shallow when the aspect ratio is less than 0.5, and deep when the aspect ratio exceeds 2 (Ahmad et al., 2005, Jamei et al., 2016).

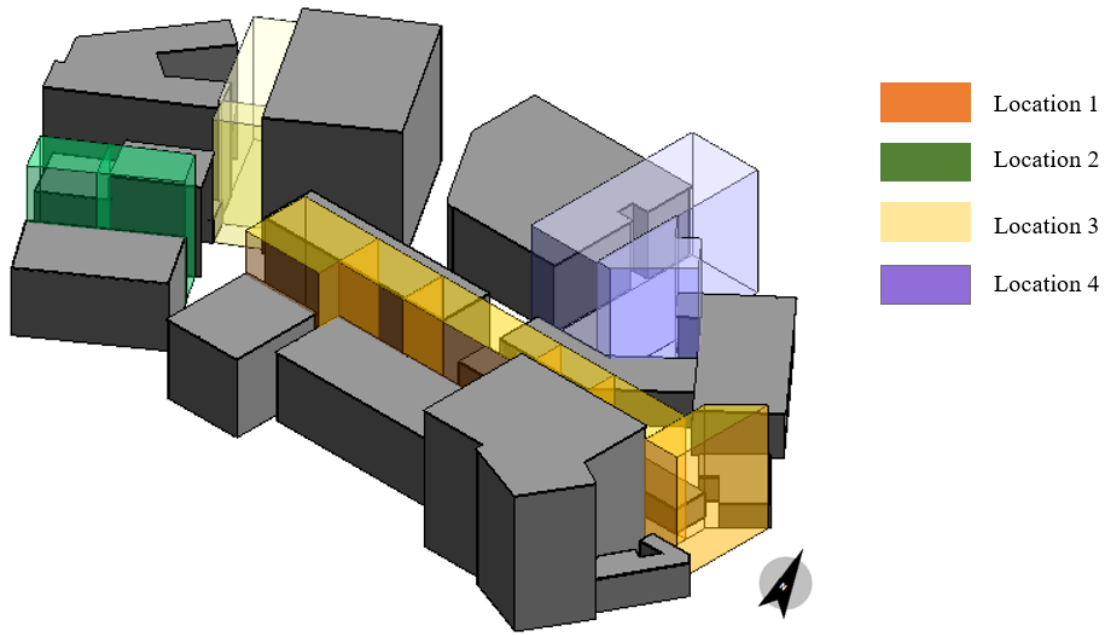

Figure 6.9 Different zones of AUT for analysing wind speed

6.5.2 Results of wind speed analysis location 1

Location 1 is a street that spans 200 m in length and 15 m in width, oriented in a west-east direction. This location has an orientation of approximately 45 degrees relative to both main wind directions in Auckland. The street consists of six different zones with varying aspect ratios. Based on the results obtained from Ansys simulations, it is evident that during the summer, the most challenging conditions in this location are posed by north-east winds. According to Figure 6.10, the zone with an aspect ratio of 1.3 experiences an average summer wind speed of 6.83 m/s, which is significantly uncomfortable, as shown in Figure 6.8 Three other zones with aspect ratios of 1.8, 2.1, and 0.8 have moderately unpleasant conditions. These zones still experience moderately unpleasant conditions in winter.

Based on Figure 6.10, it is evident that while both predominant wind directions have a 45-degree angle with location one, winds from the north-east (summer winds) are more challenging than winds from the south-west (fall, winter, spring winds). This highlights the

importance of building arrangements in the location, as the height of buildings facing north-east winds is lower than buildings facing south-west winds initially in this location (average 16 m to 38 m), and the wind speed in summer is higher than in other seasons. Furthermore, based on the results of analysing various aspect ratios, we can conclude that wider areas can have less unpleasant wind speed, especially when the heights of buildings on both sides are equal (aspect ratio: 0.3) in this location.

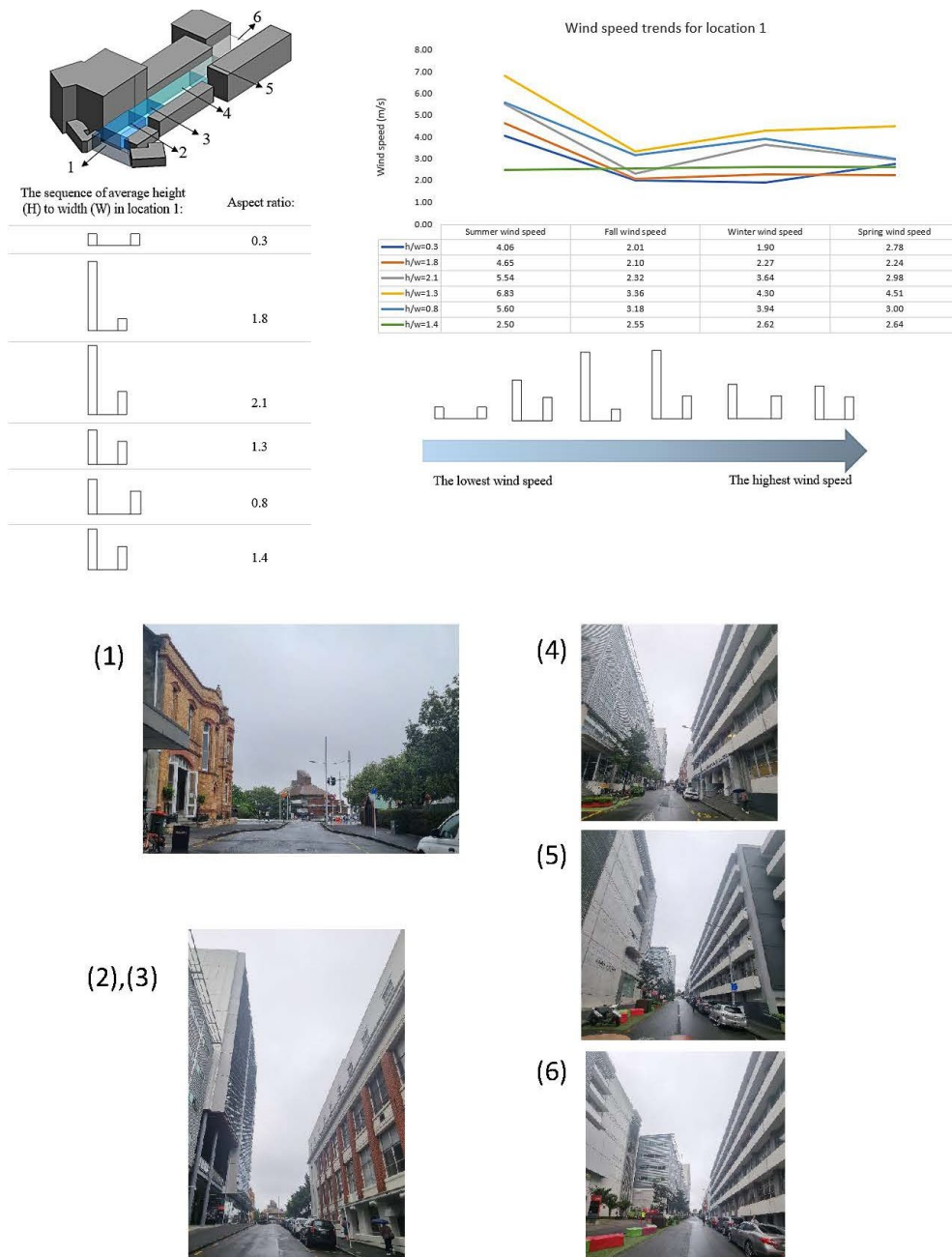

Figure 6.10 Results of wind speed analysis location 1

6.5.3 Results of wind speed analysis location 2

Location 2 is a street that measures 60 m in length and 15 m in width, running in a northeast-southwest direction. This location aligns with both main wind directions in Auckland. The street comprises two distinct zones with relatively deep aspect ratios, specifically 2.0 and 1.6 (Figure 6.11). Based on the results obtained from Ansys simulations, it is evident that this location does not face wind comfort challenges from both predominant wind directions in all periods; the wind speed remains below 3.4 m/s. Moreover, the wind speed in this location has a direct correlation with the aspect ratio, indicating that the wind speed increases with a deeper aspect ratio.

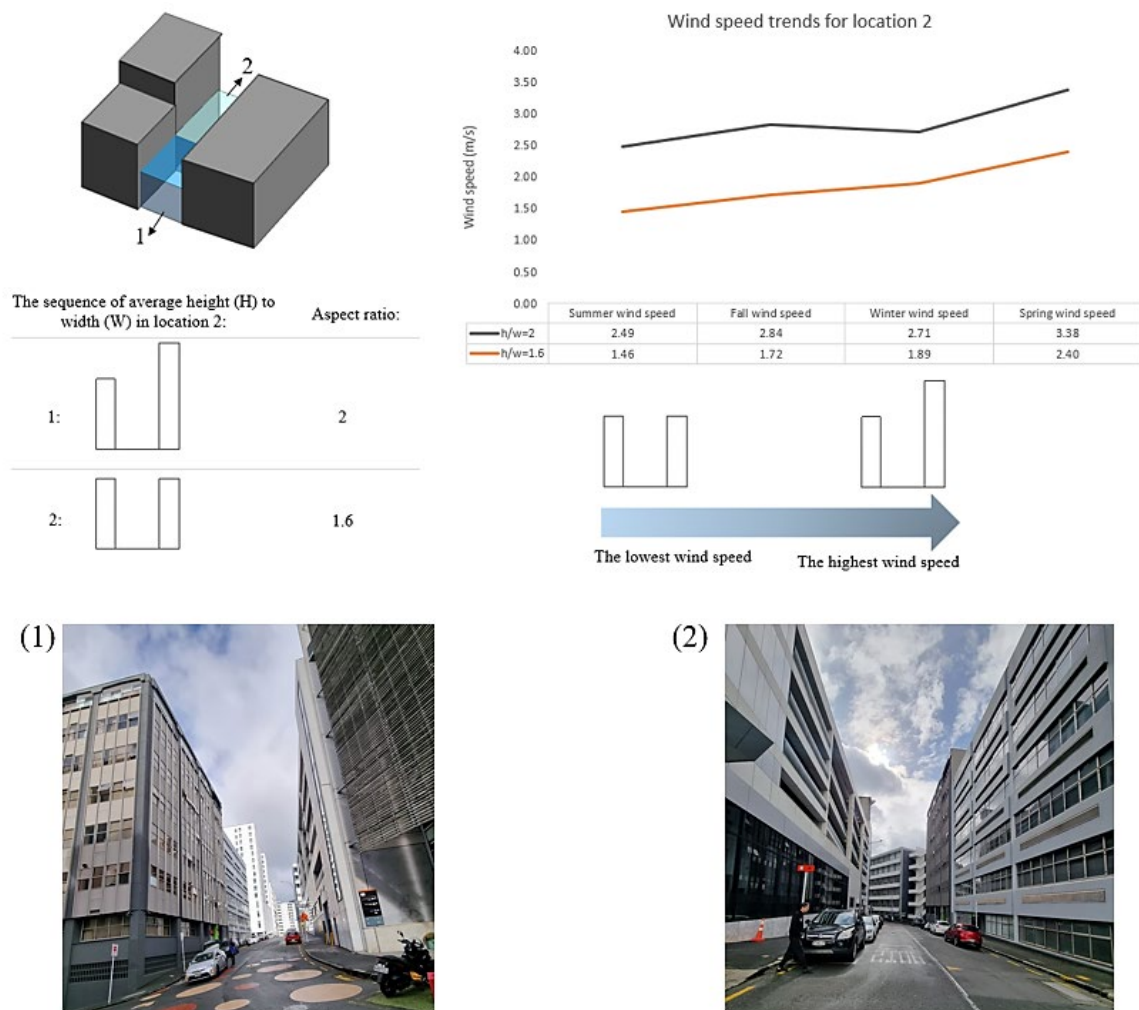

Figure 6.11 Results of wind speed analysis location 2

6.5.4 Results of wind speed analysis location 3

Location 3 is a street that measures 60 meters in length and 18 meters in width, running in a northwest-southeast direction. This location has an orientation of approximately 90 degrees relative to both main wind directions in Auckland. This street comprises two distinct zones with relatively deep aspect ratios. Based on the results obtained from Ansys simulations, it is evident that in all periods, the wind speed remains below 3.3 m/s, indicating that Location 3 does not present any comfort challenges based on wind speed (Figure 6.12). Moreover, the wind speed in this location has a direct correlation with the aspect ratio, indicating that the wind speed increases with a deeper aspect ratio.

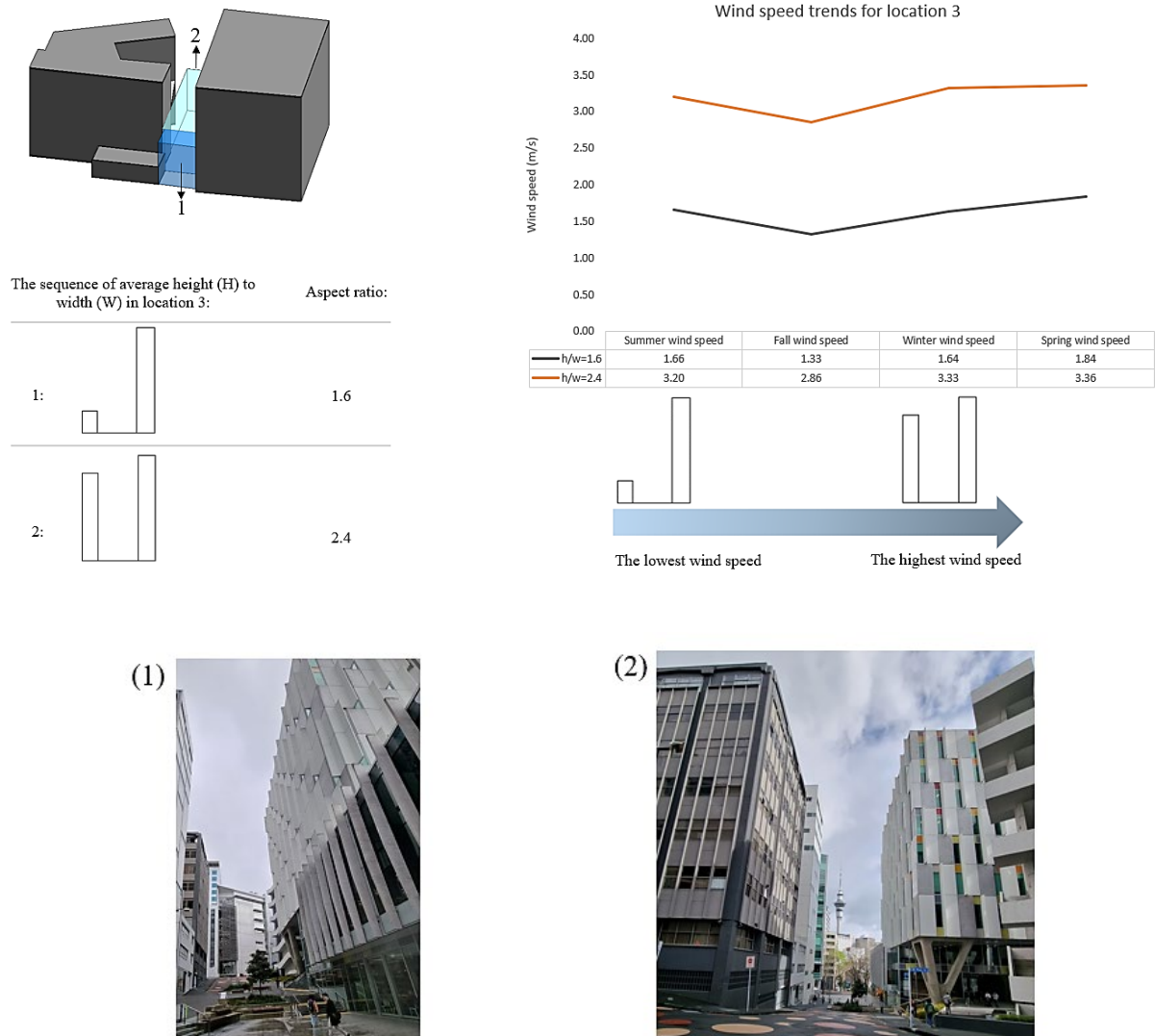

Figure 6.12 Results of wind speed analysis location 3

6.5.5 Results of wind speed analysis location 4

Location 4 is a plaza with an area of 900 m², situated in a north-south direction. This location has an orientation of approximately 45 degrees relative to both main wind directions in Auckland. The plaza comprises two different aspect ratios, both of which are relatively shallow: 0.2 and 0.8. As illustrated in Figure 6.13, both areas exhibit unpleasant conditions during the summer, similar to location one, with average wind speeds of 4.32 m/s and 3.53 m/s, respectively. This emphasizes the importance of building arrangements in the location, as the height of buildings facing north-east winds is lower than buildings facing south-west winds

initially in this location (average 12 m to 24 m). Moreover, the wind speed in this location has a direct correlation with the aspect ratio, indicating that the wind speed increases with a deeper aspect ratio.

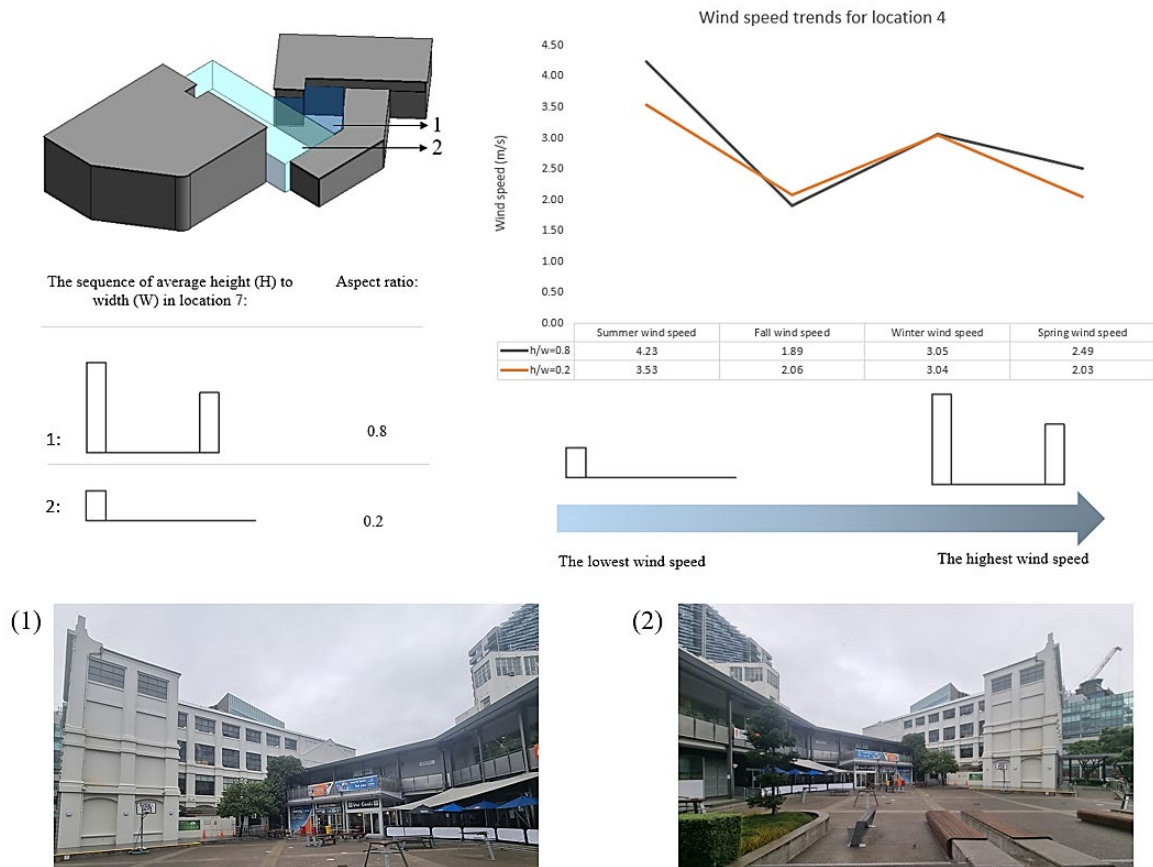

Figure 6.13 Results of wind speed analysis location 4

6.6 Defining mitigation scenarios in high-risk areas (Phase 3)

After analysing the wind speeds based on historical data in different locations at AUT, we have identified that the wind speed during summer presents a challenge in 7 different zones, and wind speed during winter is a challenge in 3 different zones. The highest risk areas that exposed risks for both summer and winters are in location 1, therefore location 1 is the high-risk area of AUT that needs mitigation scenario. The simulation results indicate that, the wind speed remains below 3.4 m/s in all periods and locations during fall and spring, which means within the tolerable and perceptible range based on comfort criteria.

Based on the simulation results, three different zones are exposed to moderate and significantly unpleasant wind speed conditions during both summer and winter, with speeds exceeding 3.4 m/s (Figure 6.13 6.14-e). Consequently, we have endeavoured to define new aspect ratios for these zones and establish tolerable and perceptible wind speed ranges in these areas.

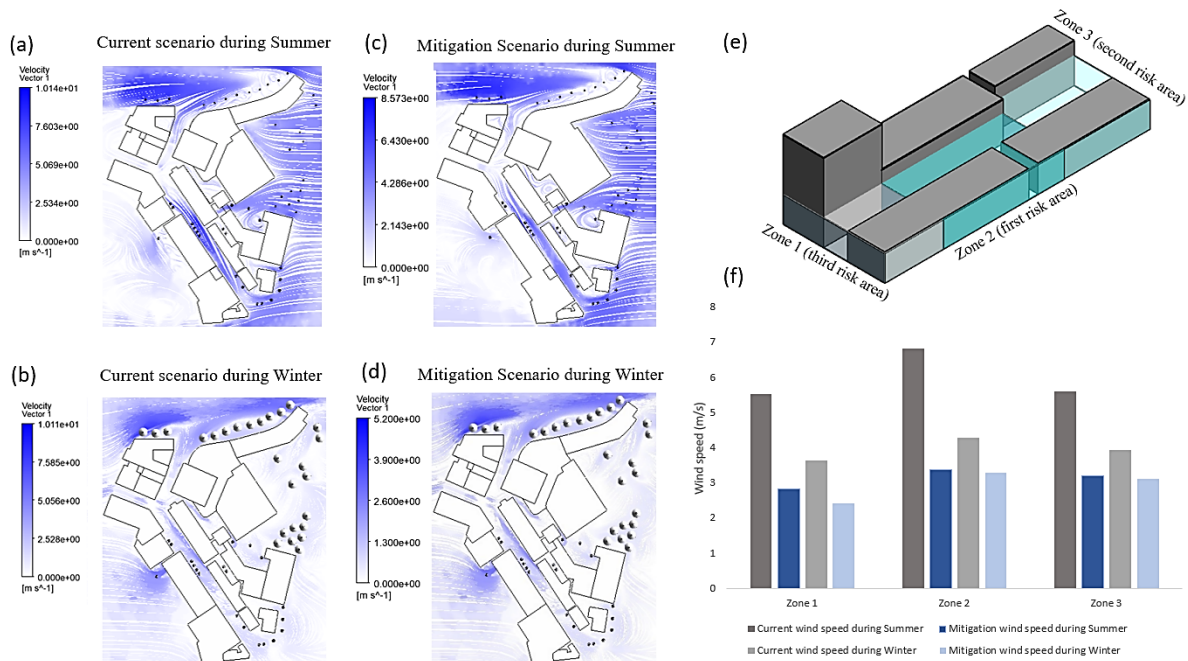

Figure 6.14(a): current scenario during summer, (b):current scenario during winter, (c): mitigation scenario during summer, (d): mitigation scenario during winter, (e): risk areas, (f): current and mitigation wind speed in risk areas

The three high-risk areas are located adjacent to each other in Location One. The highest risk area is situated between two buildings with heights of 24 m and 16 m, with a width between them measuring 15 m (aspect ratio: 1.3), specifically in zone two, as depicted in Figure 6.14-e. Based on Figure 6.14-a and Figure 6.14-b, the average wind speed in this area is 6.83 m/s in summer and 4.30 m/s in winter.

The second high-risk area is positioned between two buildings with heights of 24 m and 16 m, and the width between them is 24 m (aspect ratio: 0.8), located in zone three according to

Figure 6.14-e. According to Figure 6.14-a and Figure 6.14-b, the average wind speed in this area is 5.60 m/s in summer and 3.94 m/s in winter.

The last high-risk area is situated between two buildings with heights of 48 m and 16 m, and the width between them measures 15 m (aspect ratio: 2.1), found in zone one as shown in Figure 6.14-e. Based on Figure 6.14-a and Figure 6.14-b, the average wind speed in this area is 5.54 m/s in summer and 3.64 m/s in winter.

To mitigate wind speed in both summer and winter in these areas, we defined new scenarios by altering the aspect ratios of each zone. Since these locations are adjacent to each other, we decided to implement a similar pattern for all of them.

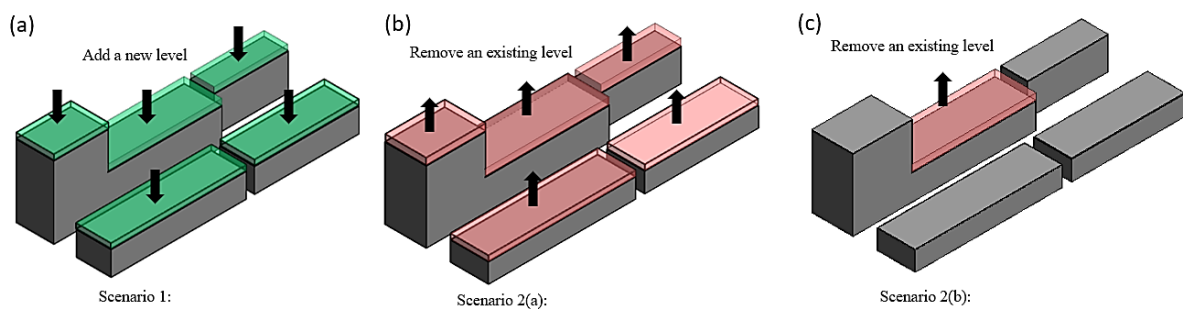

Figure 6.15 (a): first scenario (increasing aspect ratio) (b): second scenario (decreasing aspect ratio, part 1) (c): second scenario (decreasing aspect ratio, part 2)

6.6.1 First Scenario: Increasing Aspect Ratio (add a new level)

In the first scenario, we increased the aspect ratio in these zones by adding an additional level to buildings on both sides of the canyons (Figure 6.15-a). As a result, the new aspect ratios were 2.4 for zone 1, 1.6 for zone 2, and 1 for zone three. After simulating wind speeds for both summer and winter with the new scenario, the comfort criteria worsened in these zones, with wind speeds increasing by approximately 0.5 to 1.5 m/s in high-risk areas. Therefore, increasing the aspect ratio is not a suitable scenario for these high-risk areas.

6.6.2 Second Scenario: Decreasing Aspect Ratio (remove an existing level)

In this scenario, we decreased one level of buildings on both sides of the canyons, resulting in new aspect ratios of 1.7 for zone 1, 1 for zone 2, and 0.6 for zone 3 (Figure 6.15-b). After simulating wind speed for both summer and winter with this new scenario, the comfort criteria improved significantly in these zones. For zone 1 and 3, the new scenarios indicated a tolerable range of wind speed for both summer and winter, with wind speeds decreasing from 5.54 m/s to 2.85 m/s in summer and from 3.64 m/s to 2.42 m/s in winter for zone 1, and from 5.60 m/s to 3.20 m/s in summer and from 3.94 m/s to 3.12 m/s in winter for zone 3. For zone 2, although the new scenario led to a decrease in wind speed within an acceptable range for winter (from 4.30 m/s to 3.45 m/s), the wind speed in summer decreased to 4.5 m/s, which is still moderately unpleasant. Therefore, we defined another new scenario for zone 2 by decreasing the aspect ratio to 0.93 (Figure 6.15-c), resulting in summer and winter wind speeds reaching 3.39 m/s and 3.31 m/s, respectively, within a tolerable range (Figure 6.14-c, Figure 6.14-d).

Based on the defined new scenarios and simulated results, decreasing aspect ratios in high-risk areas can mitigate wind speed in this study (Figure 6.14-f).

6.7 Discussion

After simulating wind speeds for various time periods using historical data, we identified three zones with wind speeds falling into moderately or significantly unpleasant conditions during summer and winter. Consequently, we formulated various mitigation strategies.

From our analysis, the following key findings emerged:

- **Orientations:** According to the analysis results, it is evident that street orientations predominantly influenced by wind speed are the most critical factor in assessing wind comfort criteria, compared to building arrangements and aspect ratios. Streets oriented at a 45-degree angle to prevailing winds face the most significant wind challenges,

followed by those at 90-degree angles. Conversely, streets parallel to predominant winds experience fewer challenges, even when they share the same aspect ratios as the most challenging areas. Therefore, it can be concluded that future designers should prioritize the consideration of street orientations when analyzing wind speed, ahead of other factors. Previous studies have also identified street orientation as a significant factor influencing wind speed.

- Arrangements: As locations parallel to wind speed or with 90-degree orientations to prevailing winds do not present wind challenges based on wind comfort criteria in this research, our analysis focused solely on building arrangements in challenging areas. From this, it can be concluded that, for mitigating wind speed in these areas, designing high-rise buildings at the street's edge facing the predominant winds should be prioritized. In this scenario, tall buildings can effectively block intense winds in these challenging locations, thereby reducing wind speed in those areas.
- Aspect Ratio: This study reveals distinct wind speed patterns influenced by aspect ratios in various directions and locations. Consequently, it becomes imperative to prioritize the analysis of diverse orientations before considering the impact of this factor in future studies. Nevertheless, our analysis indicates a clear correlation between wind speed and aspect ratio within the same location. Deeper aspect ratios correlate with increased wind speed, while wider areas tend to exhibit less unfavorable wind conditions, especially when the buildings' heights on both sides are equal. Additionally, within similar aspect ratios, the geometry of the ratio becomes a critical factor. Our analysis highlights that among areas sharing similar aspect ratios, those with greater width experience reduced wind speeds in comparison to areas with the same aspect ratio but different dimensions.

6.8 Limitations of the study

The high accuracy of CFD in simulating wind speeds has been validated for this location. For more comprehensive results, future research should consider employing Ansys in different urban contexts. However, Ansys Fluent is suitable for modelling various fluid flow phenomena, but it has limitations when simulating vegetation, particularly trees. In this study, due to the limited number of young trees located away from the main areas, we have represented them as simple shapes with real height and width in simulations. Nevertheless, in locations with a significant number of trees, where factors like leaf properties, dynamic growth, and seasonal changes are important, Ansys may have limitations. The accuracy of wind speed simulations under these conditions should be validated in future research. Furthermore, the results regarding the impacts of orientations, building arrangements, and aspect ratios on wind speed are derived from the analysis of the AUT City Campus in Auckland. To gain a more comprehensive understanding, future researchers should analyse these factors in various urban contexts.

6.9 Moving beyond local context

While this research focused on pedestrian-level wind speed analysis in the context of Auckland, the results and achievements can be developed and extended to other parts of the world. In the initial stage of this study, we designed a modified comfort criteria range based on a combination of wind comfort criteria from the Auckland Council and the Beaufort Scale. This highlights the importance of designing wind comfort criteria based on the local conditions of various locations to achieve more accurate results in analysing wind comfort conditions in outdoor spaces based on wind speed.

Considering various urban design factors, such as aspect ratio, building arrangements, and orientations, this research can either support or challenge previous findings (Table 6.3).

Defining the wind comfort range is linked to other weather conditions, like air temperature and humidity. For example, in tropical climates, the higher air temperature and humidity might expand the acceptable range of wind speed as a comfort criterion. This encourages designers to create areas with natural ventilation or increased wind velocity. These results emphasize the importance of analysing how different urban designs impact wind speed comfort criteria, considering location-specific weather conditions. While some previous research can guide future designs, it is crucial to recognize that certain factors' impact on wind comfort conditions may vary by location. Therefore, the analysis of different urban designs should consider the specific local conditions of the chosen location.

Table 6.3 Comparing the results of this study and previous studies

Results of this research	Previous research results
Orientation:	
<p>Streets oriented at a 45-degree angle to prevailing winds face the most significant wind challenges, followed by those at 90-degree angles (wind speed more than 3.4 m/s). Conversely, streets parallel to predominant winds experience fewer challenges (wind speed less than 3.4 m/s).</p>	<p>Streets oriented parallel to the prevailing wind has greater wind velocity than those oriented perpendicular to the wind (Jareemit & Srivanit, 2019).</p> <p>Main streets should be arranged along the prevailing wind direction to face fewer wind challenges (Yuan & Ng, 2012).</p> <p>The street orientation to the prevailing winds also is important: the highest reductions were observed for perpendicular directions and best penetrations are made for parallel directions (Kitous et al., 2012).</p> <p>The angle of the upwind has an important effect, when it is perpendicular to the canyon axis, resulting in wind speeds lower than 3 m/s at the pedestrian level. With an oblique upwind direction to the canyon</p>

axes, cross-type points play a role in enhancing the wind speed at the pedestrian level. When the wind flow is parallel to the canyon, the relation with the upwind and pedestrian wind has a relatively higher relationship (Arkon & Özkol, 2014).

Arrangement:

For mitigating wind speed in challenging areas (wind speed more than 3.4 m/s), designing high-rise buildings at the street's edge facing the predominant winds should be prioritized.

The uniformity of building heights has a negative effect on enhancing pedestrian-level wind speed (Arkon & Özkol, 2014). Substituting low-rise structures with high-rise buildings may lead to a reduction in wind speed and the potential for natural ventilation in specific adjacent street canyons (Huang et al., 2020). The effects of an urban high-rise building on its surrounding wind environment are case-specific (Kuo et al., 2020).

Aspect ratio:

There is a clear correlation between wind speed and aspect ratio within the same location. Deeper aspect ratios correlate with increased wind speed, while wider areas tend to exhibit less unfavorable wind conditions, especially when the buildings' heights on both sides are equal. Among areas sharing similar aspect ratios, those with greater width experience reduced wind speeds in comparison to areas with the same aspect ratio but different dimensions.

The wind velocity in shallow canyon is mostly higher than those in the deep canyon. However, increasing the canyon length considerably improves the low wind speed in the deep canyon up to twice (Jareemit & Srivanit, 2019).

In streets with lower H/W ratios, when $0 < H/W \leq 1$, the canyon effect can be seen as lower pedestrian-level wind speeds (Arkon & Özkol, 2014).

In street canyons characterized by a unit aspect ratio, the experimental findings reveal that void decks can result in a

twofold increase in pedestrian-level wind speed, in contrast to reference canyons lacking void decks(Chew & Norford, 2018).

6.10 Conclusions

As wind speed plays a critical role in assessing human comfort in different urban areas, this research aimed to analyse the range of wind speeds for different time periods at Auckland University of Technology (AUT) based on various building aspect ratios. The study's objectives were to identify the most challenging time periods and high-risk areas within this location and to propose new scenarios for optimizing the area to maintain a tolerable range of wind speeds throughout the year. For this study, AUT was divided into 4 different locations, each further divided into different zones based on their aspect ratios, totalling 12 zones. We utilized both field surveys, including questionnaires, and software simulations using ANSYS to understand people's sensations and the range of wind speeds at AUT.

Based on our research findings, the following conclusions can be drawn:

- Among the 706 survey participants, over 55% reported experiencing windy conditions in both summer and winter in the selected location. These findings are consistent with Auckland's climate data, which shows that windy conditions are prevalent throughout most of the year (Lorrey et al., 2014).
- By correlating surveys results with the Beaufort Scale for wind intensity, areas with wind speeds below 3.3 m/s were considered comfortable (perceptible and tolerable ranges), while areas with wind speeds exceeding 3.4 m/s were categorized as high-risk areas (moderately/significantly unpleasant) based on ANSYS simulation maps for Auckland.

- The research indicates that the most challenging conditions are associated with north-east winds during the summer, affecting seven zones, which can be considered moderately/significantly unpleasant in selected location.
- In Location 1, the zone with an aspect ratio of 1.3 can be considered the area with the highest wind speed hazard at AUT, with an average wind speed of 6.8 m/s during the summer and an average wind speed of 4.3 m/s for winter.
- The optimal scenario for achieving tolerable wind speeds during both summer and winter involves reducing aspect ratios in high-risk zones in Location 1. This scenario has been examined in previous studies aimed at decreasing wind speeds in various urban contexts (Qaid & Ossen, 2015, Abdollahzadeh & Biloría, 2021).
- Ansys simulations showed that similar aspect ratios can result in varying wind speed patterns during comparable time periods. This highlights the significance of location orientation, wind directions, building arrangements and aspect ratio shapes in understanding the impact of urban designs on wind speeds, as also recommended in previous studies (Ali-Toudert & Mayer, 2006, Abd Razak et al., 2013).

The methods and findings presented in this study are expected to provide valuable insights for urban planners and architects in assessing wind speed patterns in various urban contexts and implementing strategies to enhance human comfort. These efforts can contribute to improving the liveability of outdoor spaces in cities.

Chapter 7 The impacts of historical and future climate change projections on the outdoor thermal comfort patterns of Auckland, New Zealand

7.1 Prelude

While Chapters 5 and 6 focused on identifying outdoor thermal risk areas and analysing the impact of wind speed on outdoor comfort conditions at Auckland University of Technology, there are remaining gaps related to outdoor thermal comfort during winters, analysing future outdoor thermal conditions based on different climate predictions, and exploring various future periods to identify optimal scenarios for mitigating the impacts of climate change. Chapter 7 addresses these gaps by examining outdoor thermal comfort patterns, utilizing historical data from 2000 to 2022 for both summer and winter, employing the Physiologically Equivalent Temperature (PET) index. The chapter also explores predicted future climate patterns under different Representative Concentration Pathway (RCP) scenarios for near future (2040), mid-future (2090), and far future (2110). Results indicate an expected increase in PET for both seasons under both RCP scenarios. Mitigation scenarios highlight the significant impact of planting trees and replacing 50% of current wall materials with green walls in mitigating PET levels, ensuring comfort and a neutral thermal perception range. These strategies not only enhance human comfort but also offer co-benefits for climate adaptation and public health, providing valuable guidance for implementing initiatives aimed at improving the overall liveability of urban outdoor spaces.

7.2 Introduction

Prioritizing the thermal environment is crucial in creating effective and functional outdoor spaces, given its significant influence on human health and the overall quality of the outdoor environment (Nikolopoulou et al., 2001). Indeed, a thermally comfortable urban setting fosters residents' engagement with their surroundings, addressing daily needs. On the contrary,

uncomfortable thermal conditions can deter outdoor activities, leading to increased indoor cooling energy usage and a sedentary lifestyle, negatively impacting occupants' health and well-being (Doulos et al., 2004, Niu et al., 2015). Outdoor spaces present a significant challenge and responsibility for urban planners and researchers due to their role in promoting an active lifestyle involving social and cultural activities. Analysing and enhancing the usability of these spaces is crucial. Indeed, alleviating discomfort in outdoor areas can attract a greater number of people to the improved spaces and contribute to building climate-resilient and healthy cities (Kumar & Sharma, 2020).

The quality of urban living for residents is declining as a result of the impacts of climate change and rapid urbanization (Fong et al., 2019). Human thermal comfort is a “state of mind in which human feels satisfied within the thermal environment” (De Dear & Brager, 2002). The thermal comfort of outdoor environments is shaped by a combination of climatic and non-climatic factors (Morakinyo et al., 2019). Air Temperature (T_a), Relative Humidity (RH), Relative Wind Velocity (RVa), and The Mean Radiant Temperature (T_{mrt}) (Banerjee & Chattopadhyay, 2020) are the key climatic determinants of outdoor thermal comfort while personal aspects such as age, sex, and activity levels also have a significant impact on outdoor thermal preferences (Walton et al., 2007, Amindeldar et al., 2017, Krüger et al., 2017, Huang et al., 2018, Zölch et al., 2019, Banerjee & Chattopadhyay, 2020, Yang et al., 2020).

Many previous studies have focused on exploring the influence of urban design scenarios on the microclimate of urban spaces, utilizing both simulation and field studies (Wong et al., 2011, Chatzidimitriou & Yannas, 2016, Yang et al., 2018, Heris et al., 2020). Different review studies have examined the outdoor thermal comfort (OTC) concept across various climatic and spatial settings (Shawesh & Mohamed, 2021, Dzyuban et al., 2022, Aghamolaei et al., 2023, Aghamolaei & Lak, 2023). In their respective reviews, (Lin & Brown, 2021) explored strategies in landscape architecture for optimal thermal comfort in outdoor spaces, while

(Johansson & Emmanuel, 2006) emphasized the standardization of subjective assessment tools in outdoor field studies. (Zhao et al., 2021) delved into adaptive thermal comfort models, with a focus on data-driven techniques for both indoor and outdoor settings, while (Chen & Ng, 2012) specifically examined the experiences and perceptions of pedestrians in outdoor thermal comfort studies. (Aghamolaei & Lak, 2023) contributed insights into variations in sensations and preferences among different age groups, particularly the elderly, and (Nouri, 2018) assessed assessment approaches to identify local thresholds for outdoor thermal comfort in urban design. Concurrently, (Azevedo & Leal, 2017) evaluated existing climate and comfort policies, (Jamei et al., 2016) explored the impact of urban greening and building geometry, (Taleghani, 2018) studied strategies to mitigate urban heat island effects, and (Lai et al., 2019) investigated the cooling effects of various mitigation strategies. Synthesizing recent literature, (Aghamolaei et al., 2023) identified key parameters for a comprehensive Outdoor Thermal Comfort (OTC) assessment framework, informed by environmental and user-related factors.

Although a significant number of previous studies have focused on various aspects of outdoor thermal comfort, only a limited few have attempted to analyse the impacts of predicted future climate patterns on outdoor thermal comfort in various urban contexts (Cheung & Hart, 2014, Huang et al., 2018, Aminipouri et al., 2019, Matallah et al., 2021, Wai et al., 2021). Climate change impacts, especially increasing temperatures, have been warned about in different parts of the world (Singh & Shindikar, 2023). Therefore, it is vital to investigate the future scenarios of outdoor thermal comfort by considering the current conditions of urban elements. It is necessary to explore ways to mitigate the impacts of these urban elements on future outdoor thermal comfort conditions and provide adaptation solutions by defining new scenarios.

Auckland has a population of 1.66 million people, which is anticipated to increase by 720,000 to 2.4 million in the next 30 years. Therefore, the city requires a specific urban development strategy that serves as Auckland's Future Development plan (Source: Auckland city council).

According to Auckland city council 2017, this development will be focused on existing and new urban areas. Improving the quality of life in existing and new locations is one of the key factors in a successful urban development strategy, and outdoor thermal comfort conditions are determined to be critical for creating high-quality outside environmental design (Huang et al., 2018). Furthermore, creating comfortable urban areas through climate-responsive attitudes (Wang et al., 2018) and by considering the impacts of urban form on outdoor thermal comfort (Taleghani et al., 2015, Long & Wu, 2016, Yu et al., 2020) play an important role in creating pleasant outdoor areas. Despite this, in Auckland's future urban development plan, there is an obvious gap in understanding the relationship between future urban expansions and the impact of outdoor thermal conditions on enhancing well-being and satisfaction of people in the urban context.

New Zealand enjoys a moderate and temperate climate. Auckland is a major city in New Zealand; summers tend to be warm and humid, while winters are relatively mild. Rainfall is prevalent throughout the year. The majority of Auckland gets roughly 2000 hours of strong sunlight every year. Both average and maximum temperatures are likely to climb as a result of climate change, and the frequency of hot days in Auckland, New Zealand, is expected to rise (Mullan et al., 2016). Temperatures are projected to increase in the future, and extreme weather events - such as heatwaves and extremely high temperatures - are also likely to become more common (Eames, 2017). Days with temperatures above 25 degrees are anticipated to rise by 40 to 100 percent before 2040, and from 40 to 300 percent by 2090 (Mullan et al., 2016). In essence, Aucklanders will face three months of extra hot days, significantly increasing the risk of heat-related morbidity and mortality (Eames, 2017, Mannetje et al., 2018). Extreme heat events pose a significant threat to the health and well-being of Auckland's population (Joynt & Golubiewski, 2019), particularly for those who are either more sensitive to heat or have less capacity to adapt to their surroundings (Glover et al., 2017, Joynt & Golubiewski, 2019). As a

result of future climate change, urban planners and architects should concentrate on analysing microclimate conditions, filling knowledge gaps, and designing a guideline for improving outdoor thermal conditions in Auckland, which is New Zealand's largest and most populous city.

Against this background, the significance of this study lies in analysing the current outdoor thermal patterns and predicting future patterns in Auckland, New Zealand. Aligned with our concerns, the primary aims of this study are as follows:

1. Analysing outdoor thermal comfort patterns based on historical data of Auckland for both summer and winter.
2. Analysing the predicted future thermal comfort patterns based on RCP 4.5 and RCP 8.5 for the near future (2040), mid-future (2090), and far future (2110) of Auckland for both summer and winter.
3. Defining various mitigation scenarios for decreasing thermal discomfort

7.3 Method

This research comprises four distinct phases (Figure 7.1). In the first phase, we sought to validate the accuracy of the selected software, namely Envi-met, as the primary tool for simulating outdoor thermal comfort. This involved a comparison between observed and simulated meteorological data values. In the second phase, following the validation of the selected software, we utilized average historical meteorological data from Auckland as input for Envi-met to simulate the average range of outdoor thermal comfort for both summer and winter.

For the third phase, we employed two main Representative Concentration Pathway (RCP) scenarios—specifically, RCP 4.5 (a mid-range scenario with greenhouse gas concentrations

stabilizing by 2100) and RCP 8.5 (a 'business as usual' scenario with increasing greenhouse gas emissions). Using these scenarios, we predicted the average outdoor thermal comfort for summers and winters across three future periods: 2040, 2090, and 2110. In the final phase, after analysing the historical and predicted outdoor thermal conditions of selected locations, we endeavoured to define different scenarios. These scenarios included changing aspect ratios or increasing greenery in locations to decrease the range of thermal discomfort in the selected areas.

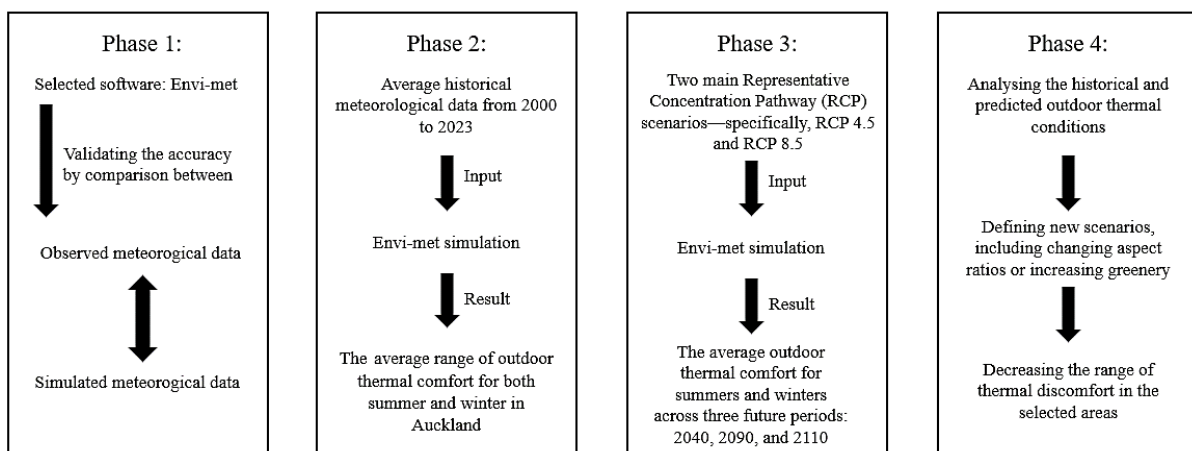

Figure 7.1 The structure of the research

For selecting a location as a case study, we decided to choose an area in the Central Business District (CBD) of Auckland. This area is the most populated and utilized part of Auckland, making it a priority for analysing outdoor thermal comfort, especially when considering the impacts of urban heat islands. Furthermore, the effects of urban planning, particularly the use of different materials and high-rise buildings with less greenery, on the microclimate are highlighted in this area. The research is conducted at the city campus of Auckland University of Technology as a sample area in the CBD, located at S-36° 51', E174° 46', with an approximate area of 38,000 m² (Figure 7.2). The study area comprises 16 buildings ranging in height from 8 to 48 meters, including different geometries and materials. The orientations of these buildings vary, ranging from north-south and west-east to northwest-southeast and

northeast-southwest, exhibiting diverse aspect ratios from shallow to deep. Vegetation cover, particularly trees, is sparse in the southern part of the location but becomes more abundant in the northern part.

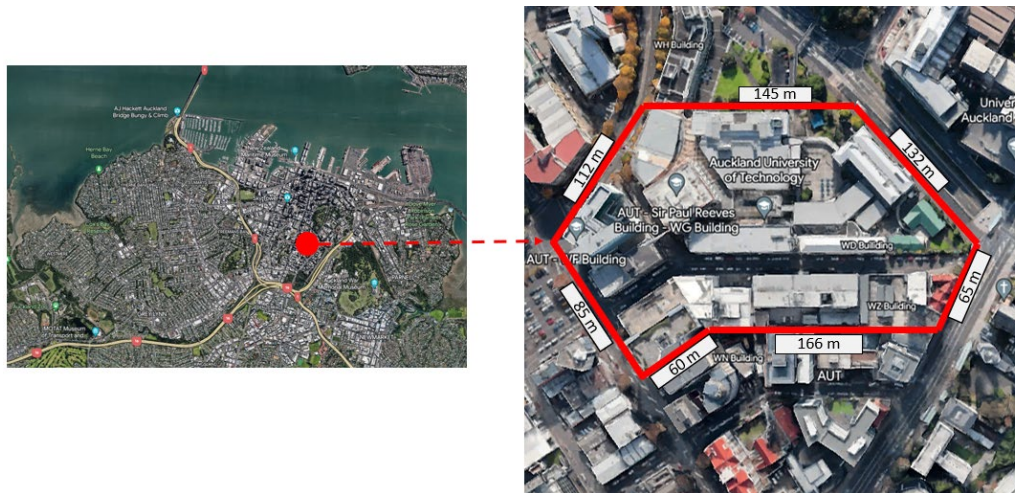

Figure 7.2 Research location

7.4 Results

7.4.1 Validate the accuracy of Envi-met (Phase 1)

To assess the outdoor thermal comfort, the research utilized the Physiological Equivalent Temperature (PET) index. The PET index serves as a metric for evaluating the level of thermal comfort in a specific location (Höppe, 1999, Blazejczyk et al., 2012). Higher PET values indicate a greater degree of thermal risk within the examined area (Huang et al., 2018). In greater detail, PET (Physiological Equivalent Temperature), PMV (Predicted Mean Vote), and UTCI (Universal Thermal Climate Index) stand out as the three frequently employed indices. These indices exhibit comparable traits, serving as universal measures applicable to both cold and hot thermal conditions. Additionally, they encompass a broad range of classifications for thermal sensation or stress and include 7 to 10 categories (Potchter et al., 2018). For this study, PET was chosen based on the findings of (Lam et al., 2021), who conducted a review revealing that over 55% of the selected prior studies utilized PET as a thermo-physiological assessment

index. PET is widely preferred in research for two primary reasons. First, many outdoor thermal comfort investigations have focused on summer heatwave conditions. Although PET, featuring a two-node body model covering both clothing-covered and uncovered segments, faces challenges in calculating the clothing section, this limitation is manageable during the summer season when individuals typically wear lightweight clothing. Second, the results obtained from PET are valuable for comparative studies involving diverse spatiotemporal variations, given its prevalent use in numerous studies (Chen & Matzarakis, 2018).

Envi-met is utilized for modelling the entire thermal environment, a capability that has been validated through various research studies, confirming its effectiveness in reproducing thermal conditions at the neighbourhood scale (Shinzato et al., 2019, Lachapelle et al., 2022). Envi-met is a microclimatic model that encompasses a three-dimensional structure, including a one-dimensional boundary model, three-dimensional atmospheric model, soil model, and plant model (Chatzinikolaou et al., 2018, Rui et al., 2019). The study grid measures 2 m x 2 m x 2 m and is based on a model with a grid size of 300 x 280 x 40.

The simulated data's accuracy was evaluated through a comparison with observed meteorological data values. Field measurements were conducted using the Davis 6152 Wireless Vantage Pro2 weather station, known for its high-quality sensors providing precise readings for temperature, humidity, wind speed, direction, and rainfall. The Vantage Pro2 sensors have a high level of accuracy, within ± 0.5 °C for temperature, $\pm 2\%$ for relative humidity, ± 2.2 km/h for wind speed, and $\pm 5\%$ for rainfall.

Two locations, St. Paul Street (location one) and Hikuwai Plaza (location two), were chosen for field measurements due to their potential to offer diverse degrees of shade. The sensors, positioned at a height of 1.5 meters at pedestrian level, continuously monitored meteorological conditions. Readings were recorded every 30 minutes from 8:30 to 16:30 on March 14 and

March 15, 2023. Subsequently, the results from these field measurements, encompassing air temperature, wind speed, and humidity, were compared with corresponding data simulated by the Envi-met software (Figure 7.3).

Location 1:

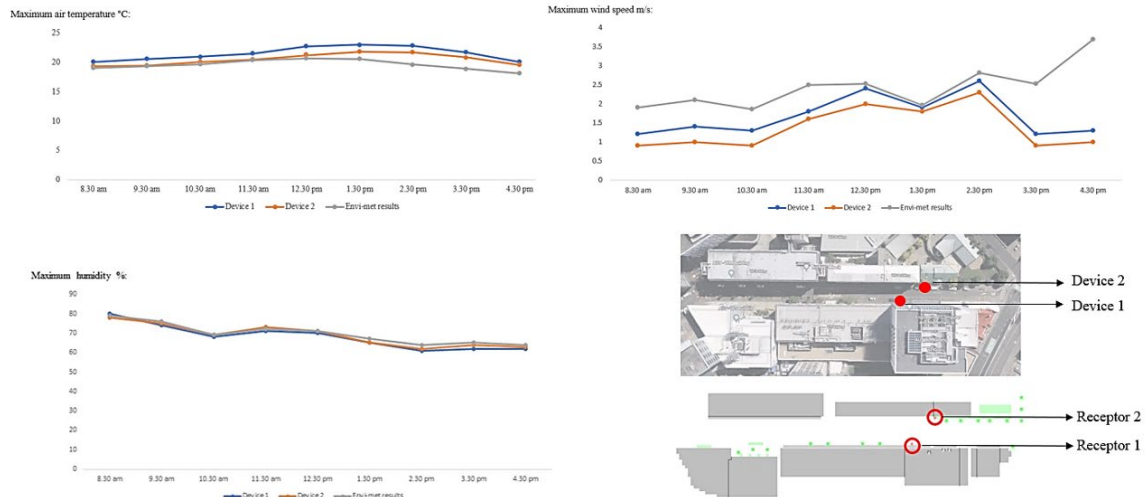

Location 2:

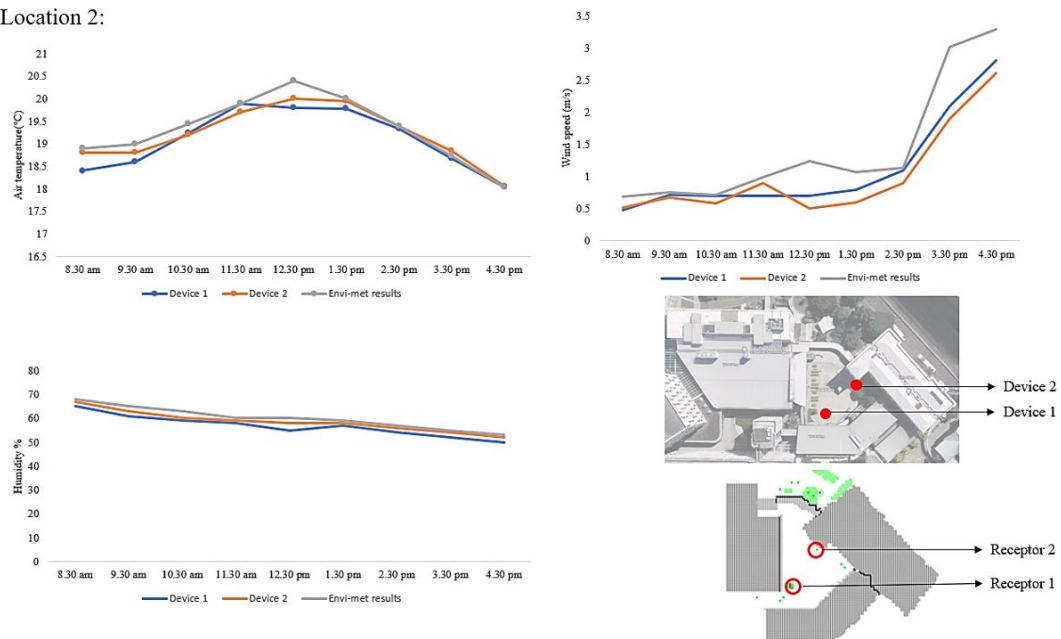

Figure 7.3 The results obtained from field measurements and Envi-met simulations for air temperature, wind speed, and humidity on March 14, 2023, in Location 1 and March 15, 2023, in Location 2

7.4.1.1. Agreement between field measurements and Envi-met simulated data

R-squared is commonly used as a method to assess the agreement between measured data and simulated data. However, it is important to note that R-squared is not the only measure to consider when comparing measured and simulated data. Especially if the assumptions of linear regression are not fully met. The key assumptions are linearity, independency of residuals, homoscedasticity, normality of residuals, and no perfect collinearity between independent variables (Hastie & Pregibon, 2017). High R-squared values can occur even when the relationship between the datasets is spurious or coincidental. Therefore, it is essential to complement the R-squared evaluation with other methods, such as visualizations and statistical tests, to gain a comprehensive understanding of the agreement or differences between the measured and simulated data (Allison, 2013).

In this research, various methods were employed to assess these assumptions. Scatter plots to verify the linearity, Durbin-Watson statistical test to detect the presence of auto correlation in the residuals, Q-Q plot along with Shapiro-Wilk statistical test to check the normality of residuals, and finally, the Residual vs. Fitted Values Plot to check homoscedasticity. No collinearity assumption does not apply to this problem as a single predictor variable is considered.

The results indicate that the assumptions of linear regression were satisfied for both air temperature and humidity. Consequently, the R-squared metric was employed to assess the concordance between field measurements and the simulated data produced by Envi-met for these two parameters. The obtained R-squared values were 0.9537 for air temperature at Location 1 and 0.9497 at Location 2, revealing a robust alignment between the measured and simulated data at both sites. In terms of Humidity, R-squared values of 0.9629 (Location 1) and 0.9497 (Location 2) were observed, similarly affirming a strong agreement between the measured and simulated data at both locations. However, it should be noted that the assumption

of normality of residuals was not as satisfied for wind speed as it was for air temperature and humidity in either location (Figure 7.4).

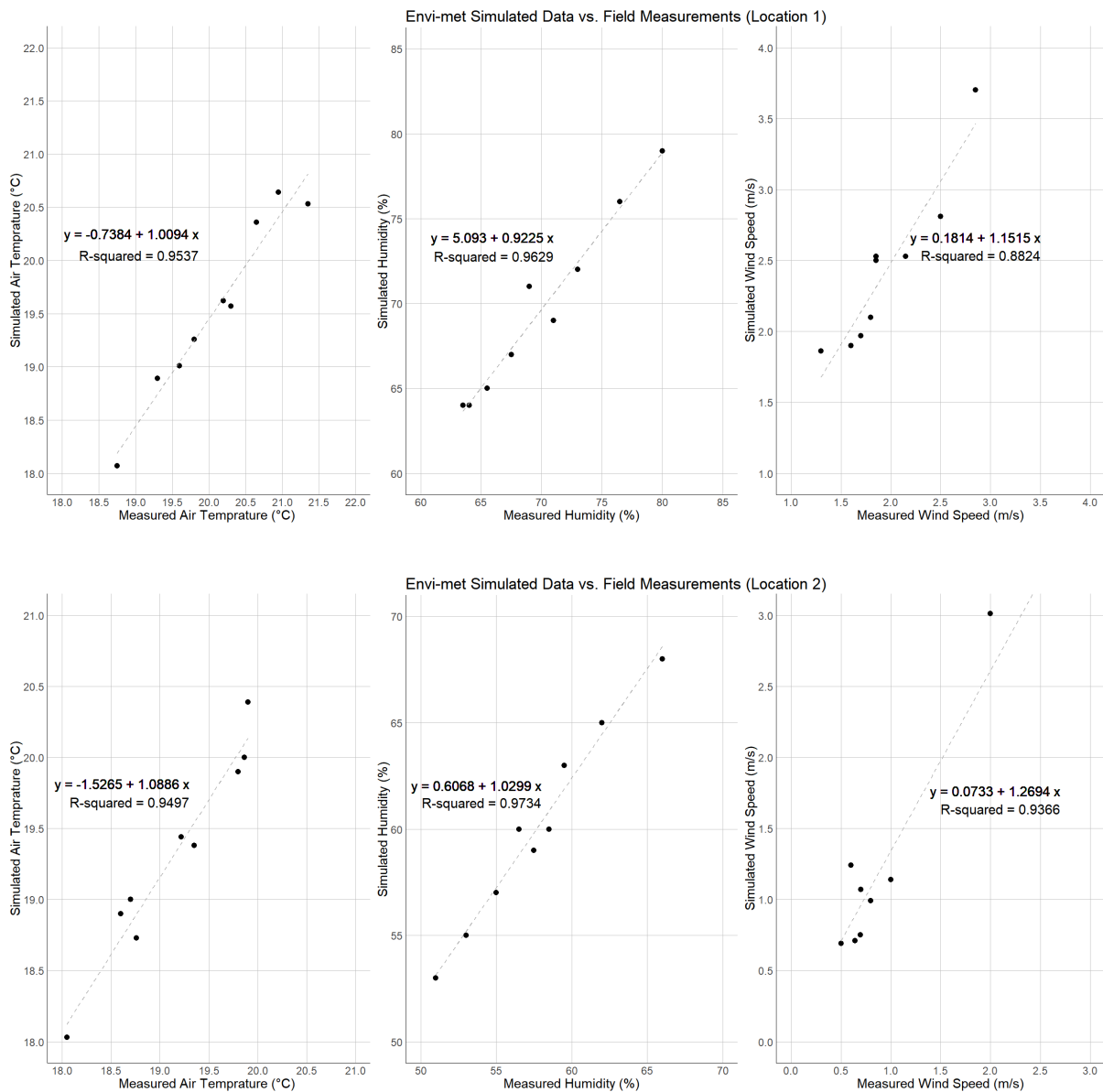

Figure 7.4 Scatter plot illustrating the measured and Envi-met simulated data points, along with the best fit line obtained from linear regression analysis.

Therefore, based on a comparison of the results from field measurements and software simulations, and considering that the R-squared value exceeds 0.88 for all factors, we selected Envi-met for analysing PET in this research.

7.4.2 Analysing the average range of outdoor thermal comfort (Phase 2)

As noted in the preceding section, AUT encompasses 16 buildings with heights spanning from 8 to 48 meters, and their aspect ratios (height-to-width ratios) range from 0.2 to 2.4. The majority of structures display a west-east orientation. These buildings are constructed using materials such as concrete, steel, brick, and glass, while pavement materials include light concrete and asphalt. Regarding vegetation cover, the primary outdoor spaces are characterized by a limited presence of young trees that offer inadequate shading and minimal wind control. Figure 7.5 illustrates diverse outdoor areas within AUT.

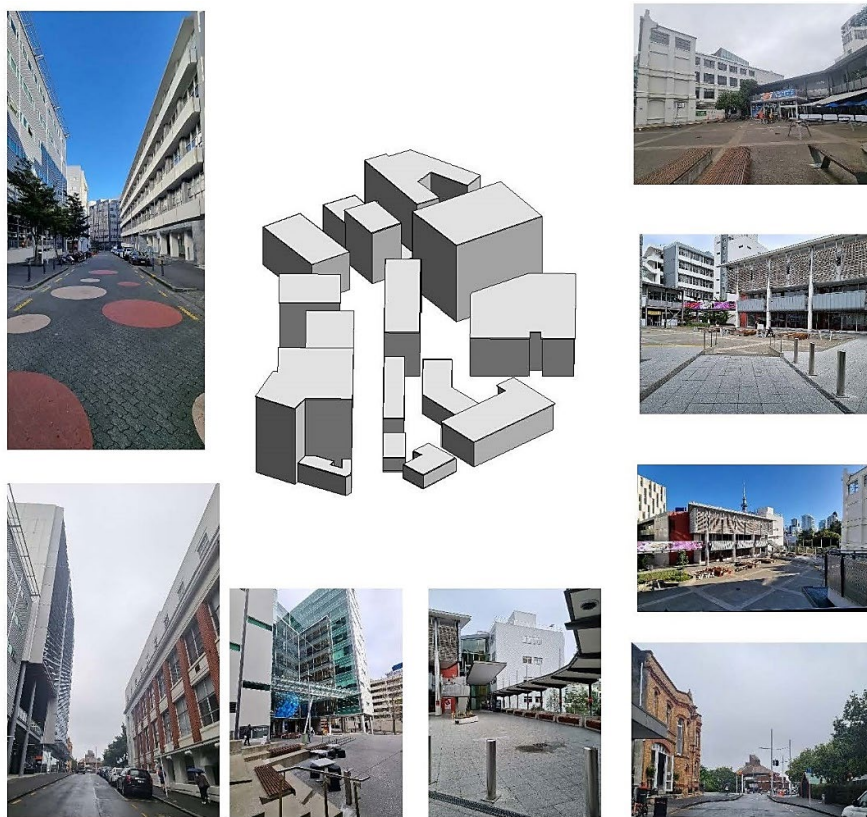

Figure 7.5 Various outdoor areas of AUT

Using historical climate data from the National Institute of Water and Atmospheric Research (NIWA), we determined that the average summer temperature in Auckland from 2000 to 2023 was 19.70 °C, while the winter temperature was 11.94 °C. Additionally, the average humidity was 71.54% in summer and 73.85% in winter, with average wind speeds of 4.81 m/s and 4.36 m/s, respectively. The wind direction for both seasons is 45 degrees relative to the selected location (Figure 7.6-d). With this data, we conducted simulations for the average outdoor thermal comfort at AUT based on the PET index using Envi-met for both summer and winter. The results are presented in Figure 7.6-a and Figure 7.6-b.

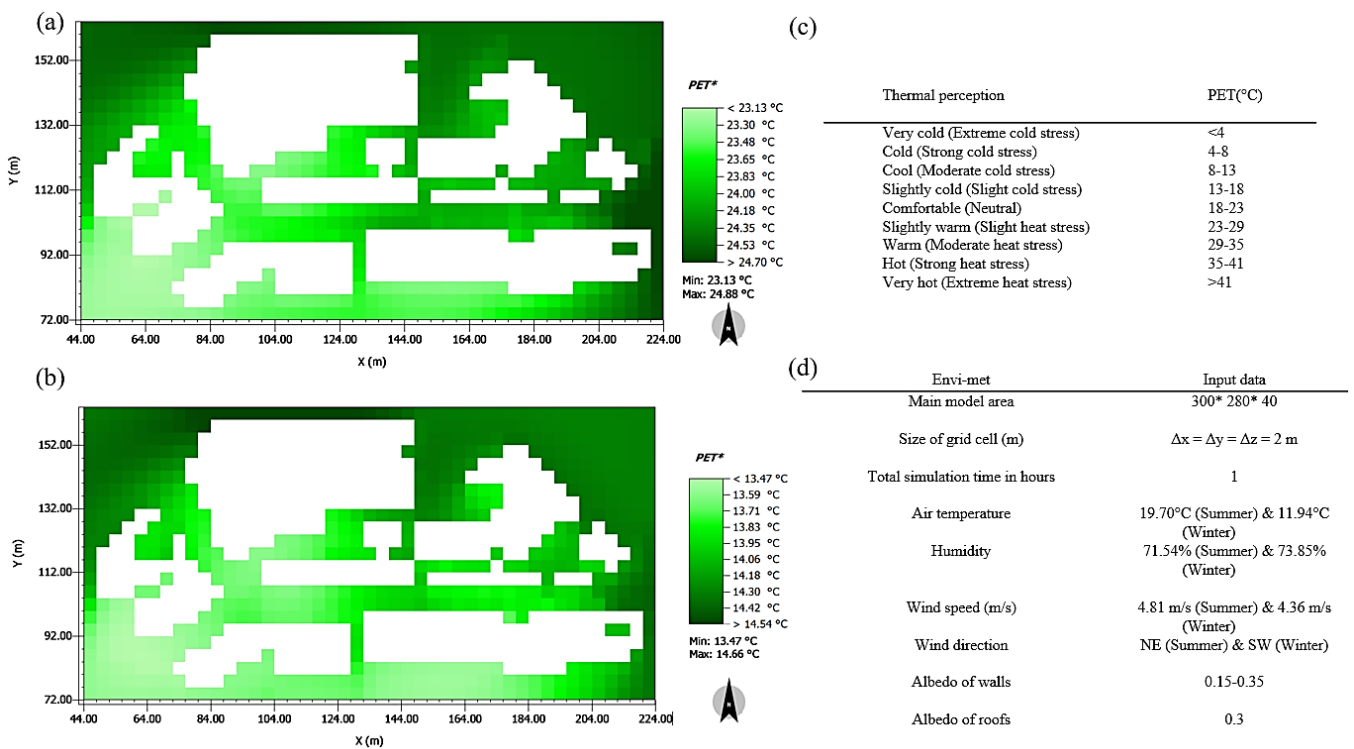

Figure 7.6 (a): the outdoor thermal comfort range for summer from 2000 to 2023, (b): the outdoor thermal comfort range for winter from 2000 to 2023, (c): categorization PET level for different thermal perception in a Cfb climate (d): : the input data for Envi-met

Auckland, characterized by a temperate climate (cfb) according to the Koppen climate classification, has a comfortable PET range between 18°C and 23°C based on a comparison of the modified PET “Neutral” sensation ranges in different climatic zones (Potchter et al., 2018)

(Figure 7.6-c). According to the simulation results, the PET range for summer in Auckland is between 23.13 °C and 24.88 °C, indicating a slightly warm condition according to thermal perception in a Cfb climate. This range decreases to between 13.47 °C and 14.66 °C during winter, signifying a slightly cold condition. Therefore, based on historical data from 2000 to 2023, AUT experiences slight heat and cold stress during both summer and winter.

7.4.3 Analysing the predicted future range of outdoor thermal comfort based on RCP

4.5 and RCP 8.5 (Phase 3)

The climate in Auckland is undergoing alterations that are expected to persist. There is widespread acknowledgment that recent global climate change is primarily attributed to human-generated greenhouse gas emissions. Further, anticipated future changes in the climate will be influenced by the continued rise of greenhouse gases in the atmosphere. The pace of forthcoming climate change depends on the rate at which these gases increase (Hopkins et al., 2015, Mason et al., 2017).

According to reports from the Auckland City Council and NIWA, the Auckland Region is expected to experience significant climate changes in the future. Using a moderate estimate, Auckland's temperature is projected to rise by approximately 0.6°C by 2040 (compared to the late 20th century), 1.2°C by 2090, and 1.4°C by 2110. However, due to uncertainties surrounding future greenhouse gas concentrations and variations in how each climate model responds to these concentrations, the projected warming ranges widely: 0.5-1.2°C by 2040, 0.3-3.3°C by 2090, and 0.4-4.0°C by 2110 (Mullan et al., 2018).

The Intergovernmental Panel on Climate Change (IPCC) utilizes a set of four future climate change scenarios known as Representative Concentration Pathways (RCPs). These four RCPs offer diverse climate projections contingent on future greenhouse gas concentrations, influenced by economic, political, and social developments throughout the 21st century.

RCP2.6 represents a mitigation scenario involving the removal of greenhouse gases, while RCP4.5 and RCP6.0 are mid-range scenarios where greenhouse gas concentrations stabilize by 2100. RCP8.5, on the other hand, represents a 'business as usual' scenario with escalating greenhouse gas emissions (Moss et al., 2010, Riahi et al., 2017). In our study analysing future outdoor thermal comfort patterns for AUT, we focused on future climate projections based on RCP4.5 and RCP8.5 for the near future (2040), mid-future (2090), and far future (2110).

The climate projections for Auckland based on Representative Concentration Pathways (RCPs) indicate increasing temperatures and changes in other climatic variables. Under RCP4.5, annual maximum temperatures (Tmax) are expected to rise by 0.75-1.00°C by 2040, 1.25-1.50°C by 2090, and 1.50-1.75°C by 2110. Similarly, under RCP8.5, projections show increases in Tmax of 0.75-1.25°C by 2040, 2.75-3.25°C by 2090, and 3.25-3.75°C by 2110, with autumn experiencing the most significant Tmax increases. For minimum temperatures (Tmin), under RCP4.5, increases are projected at 0.50-0.75°C by 2040, 1.00-1.25°C by 2090, and 1.25-1.50°C by 2110. RCP8.5 shows Tmin increases of 0.75-1.00°C by 2040, 2.50-2.75°C by 2090, and 3.00-3.25°C by 2110, with autumn consistently showing the largest increases.

Model agreement is high for temperature projections, with all models projecting increases under both RCPs at all time slices. In terms of wind speed, RCP4.5 projects a slight decrease, while RCP8.5 predicts more pronounced decreases, particularly in summer and autumn. Relative humidity is expected to decrease under both RCPs, with RCP8.5 showing more significant reductions. Overall, these climate projections suggest a warming trend in Auckland with notable variations in different seasons and under different greenhouse gas emission scenarios.

Based on the predicted future climate data, Table 7.1 and Table 7.2 display the results of simulating outdoor thermal comfort for both selected scenarios across three different time slices in both summer and winter.

Table 7.1 Predicted future outdoor thermal comfort for future summers

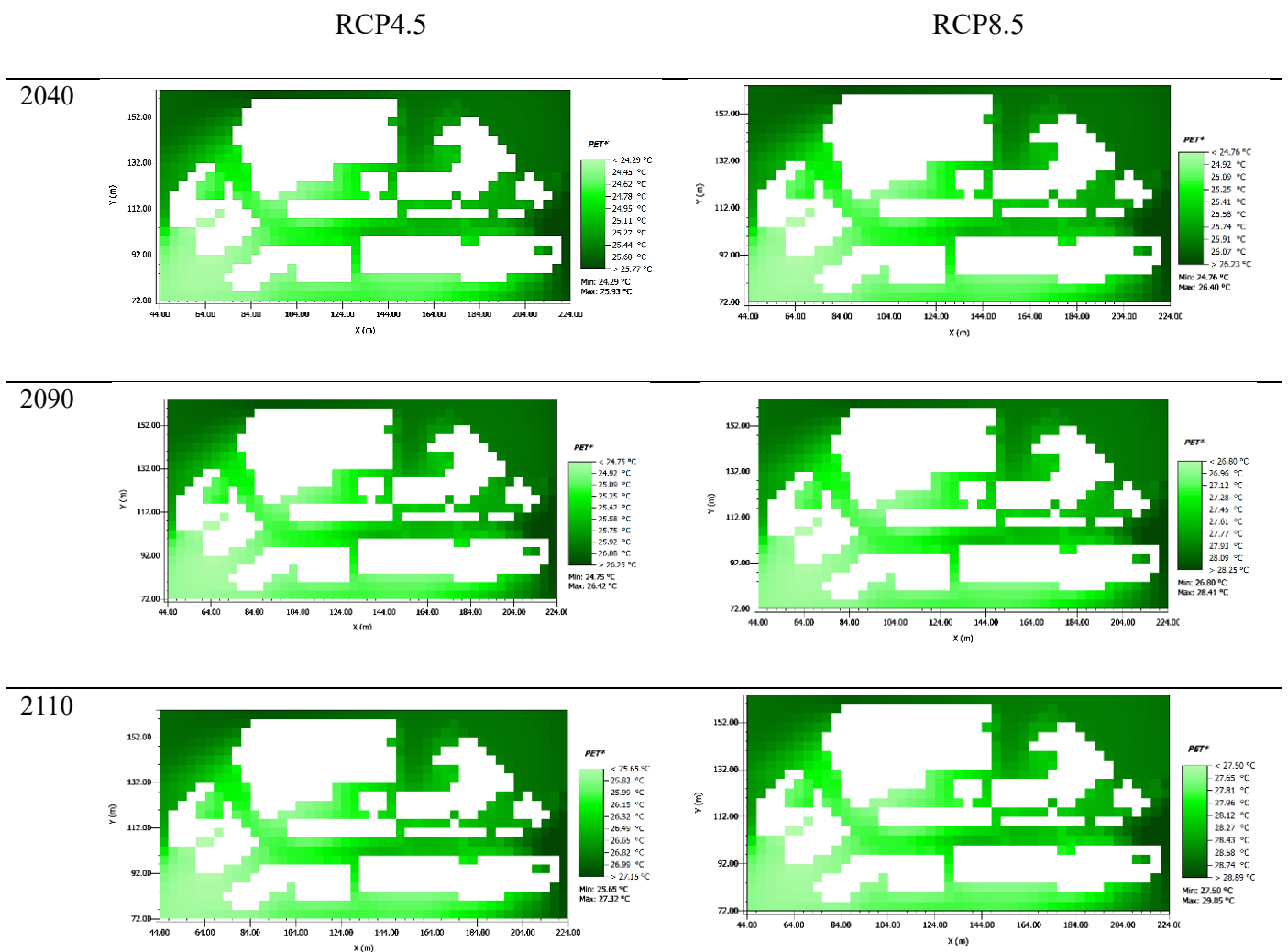

As discussed in the previous section, based on historical data, the minimum and maximum of PET range between 23.13°C and 24.88°C in summer for the selected location. According to the results of simulated future PET, this range will moderately increase for both scenarios across three selected time periods. In the worst-case scenario, the PET levels may reach a range of 27.5°C to 29.05°C in summer by the year 2110 under RCP 8.5 scenario. This shift implies that thermal perceptions will transition from slight to moderate heat stress (Figure 7.7).

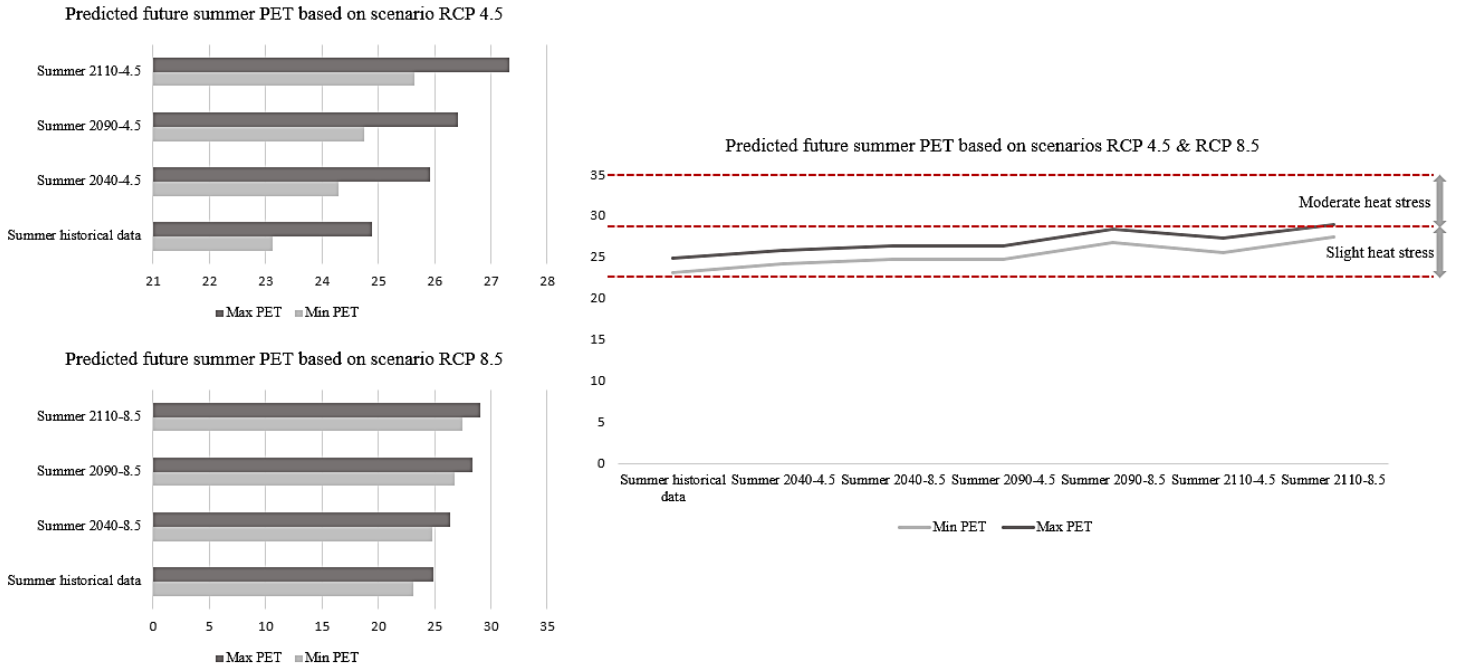
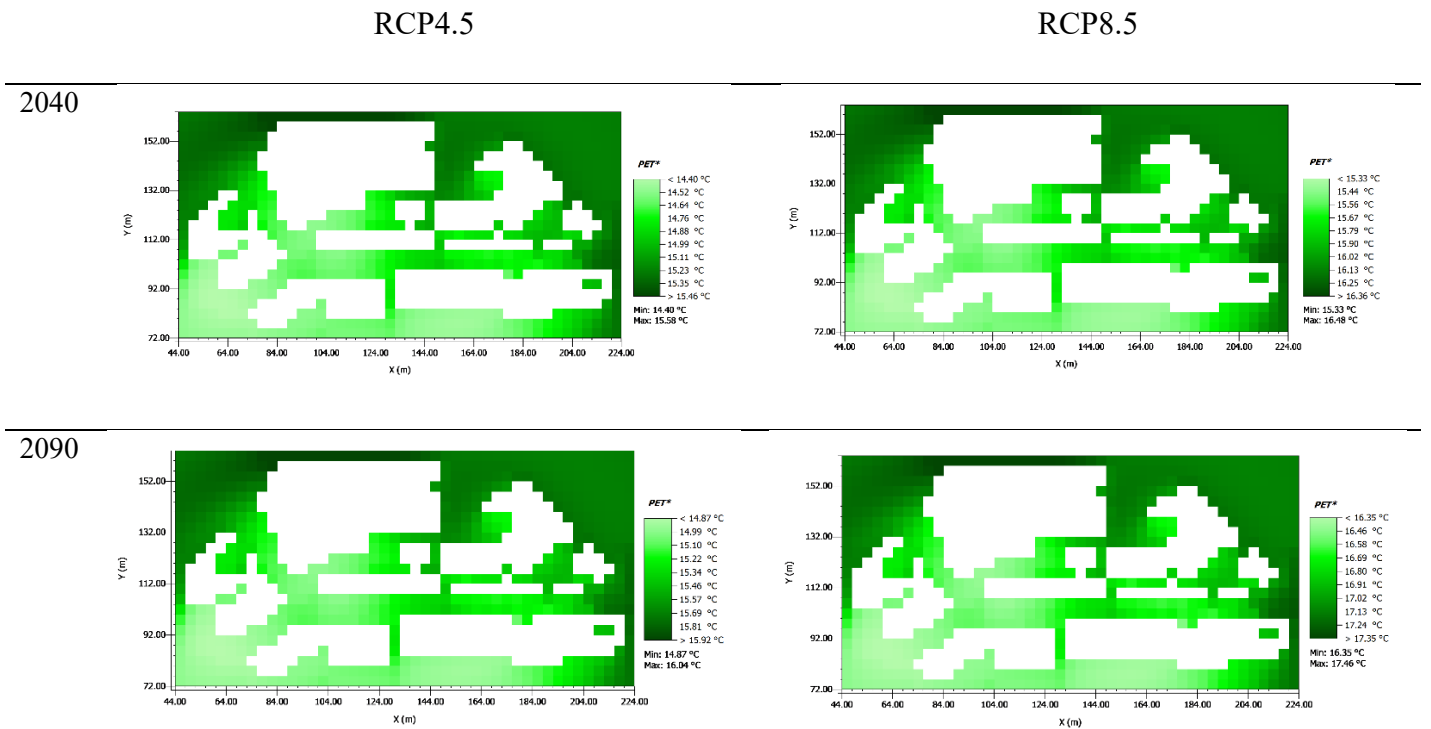
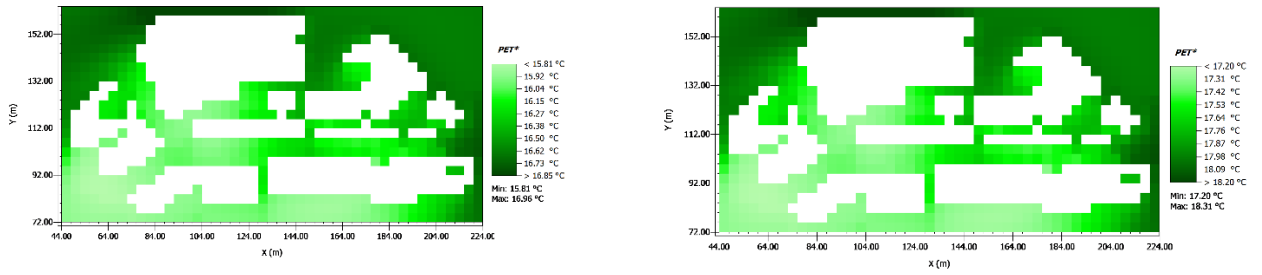

Figure 7.7 Predicted future summer PET based on scenarios RCP 4.5 & RCP 8.5

Table 7.2 Predicted future outdoor thermal comfort for future winters





As discussed in the previous section, based on historical data, the minimum and maximum of PET range between 13.47°C and 14.66°C in winter for the selected location. According to the results of simulated future PET, this range will moderately increase for both scenarios across three selected time periods. This implies that, in the future, the selected location will experience less cold stress, as the range of PET increases and may even reach 18.31°C in winter by 2110 based on scenario RCP 8.5. In such conditions, thermal perceptions will transition from slight cold stress to comfortable and neutral conditions (Figure 7.8).

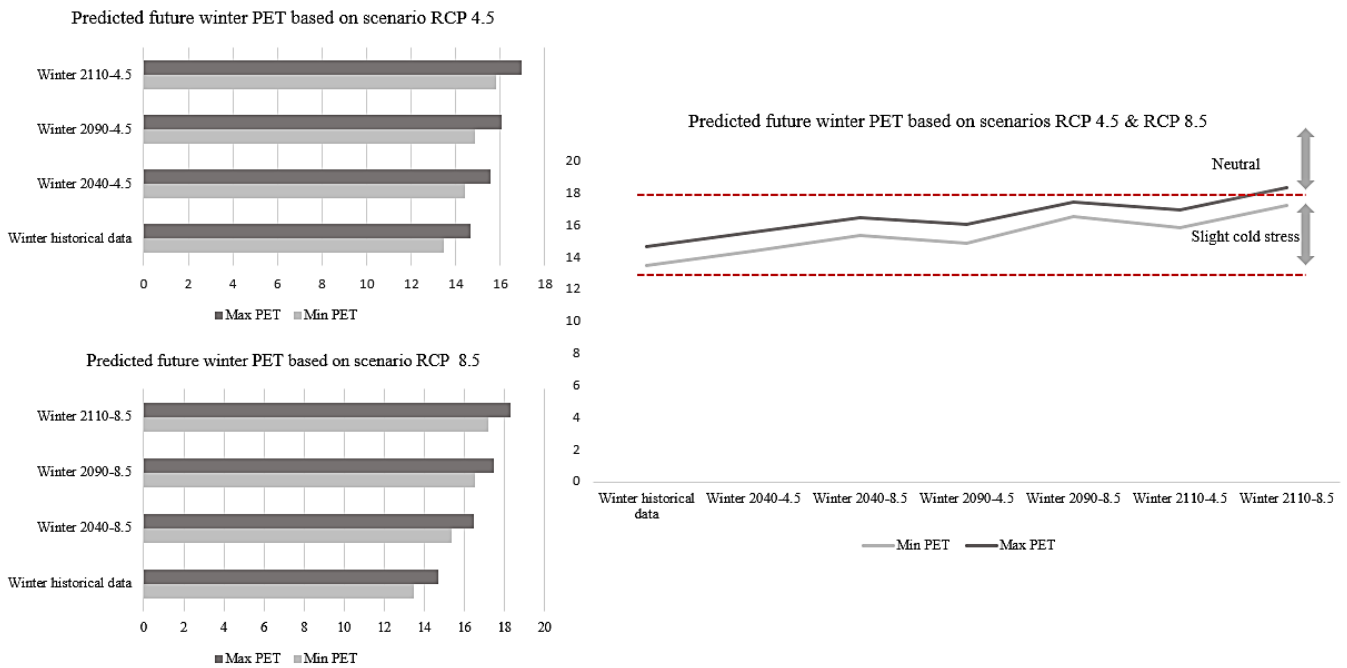

Figure 7.8 Predicted future winter PET based on scenarios RCP 4.5 & RCP 8.5

7.4.4 Results of new scenarios for mitigating outdoor thermal discomfort (Phase 4)

As discussed in the previous section, it is evident that the current outdoor thermal comfort conditions during summer entail slight heat stress, while during winter, there is a slight cold

stress. Upon analysing future outdoor thermal patterns for various scenarios, it becomes apparent that the conditions for outdoor thermal comfort during summer are projected to worsen, potentially reaching a state of moderate heat stress in one scenario. Conversely, for winter, outdoor thermal comfort conditions are expected to improve across different scenarios, reaching a state of comfort and neutrality in one of them.

Although these results suggest a future occurrence of climate change, with winters experiencing warmer periods, our research primarily focuses on providing comfortable outdoor thermal areas. Therefore, we identify summer as the risk period in Auckland, necessitating the definition of new scenarios to mitigate the impacts of climate change. To achieve this objective, given the uncertainty surrounding the specific future RCP scenario for Auckland's climate and the limitation of exploring both scenarios along with three different future time slices within the scope of this research, we have aimed to define new scenarios reflecting the current conditions of selected locations. We will simulate outdoor thermal comfort based on these scenarios. The identification of the most effective scenario is expected to yield positive impacts on Auckland's future thermal conditions, considering the future RCP scenario.

In defining new scenarios, we concentrated on two factors. The first factor is the geometry of buildings in the location, where we assessed the impact of different aspect ratios (height-to-width ratios) on PET. The second factor considers the effects of using different types of urban greenery, such as trees and green walls, on PET.

7.4.4.1. Defining new aspect ratios for assessing the level of outdoor thermal comfort

The aspect ratio, defined as the ratio between the average height (H) of the canyon and the canyon width (W), is one of the most important criteria in establishing canyon geometry (Oke, 1988, Ali-Toudert & Mayer, 2006, Gromke & Ruck, 2012). Previous studies have analysed the impacts of various aspect ratios on outdoor thermal comfort. The results show a correlation

between the aspect ratio and the orientation of canyons in facilitating thermal comfort in various climates (Ali-Toudert & Mayer, 2006, Deng & Wong, 2020, Abd Elraouf et al., 2022). AUT has five main outdoor areas that can be considered the primary gathering places for people. These locations have different canyon orientations and are surrounded by buildings of various heights, resulting in diverse aspect ratios. To assess the impact of aspect ratio on outdoor thermal comfort, we initially added a new level to all buildings, creating more depth in the areas (Figure 7.9-a). We analysed the level of Physiological Equivalent Temperature (PET) in this new scenario, revealing that the new minimum PET would be 23.09 °C, and the new maximum PET would be 26.42 °C (Figure 7.10). Consequently, by comparing current PET levels with the new ones, we observed that increasing the aspect ratio could worsen the PET levels in this location.

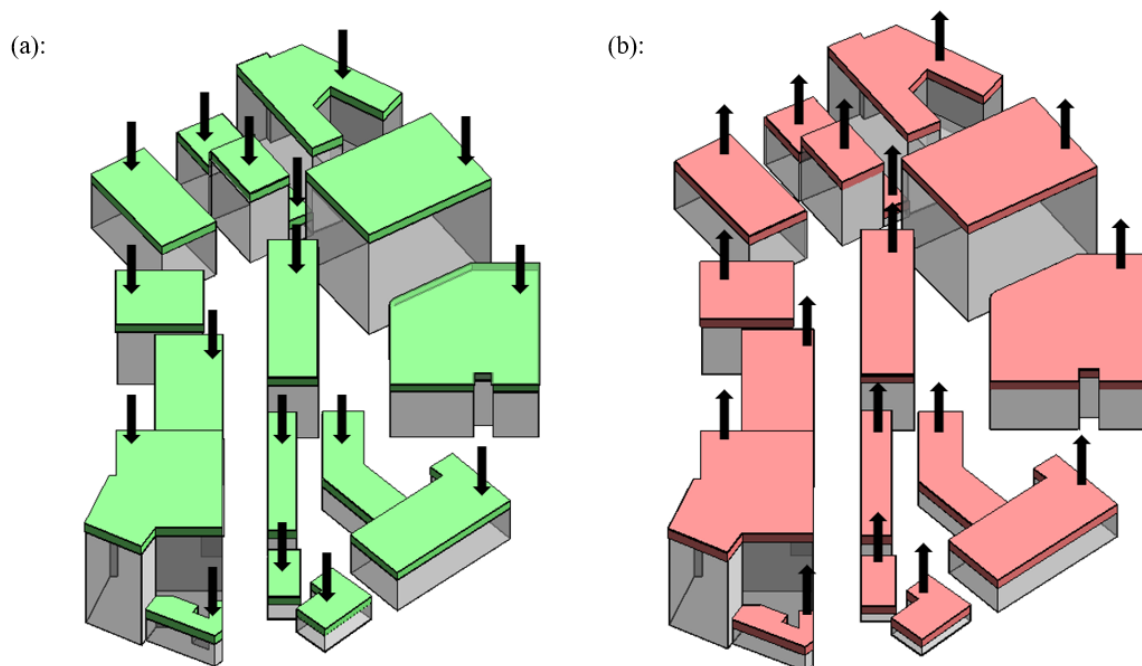

Figure 7.9(a): Increasing the aspect ratio by adding a level for analysing the level of PET, (b): Decreasing the aspect ratio by removing a level for analysing the PET level

Subsequently, we removed one level from all buildings in AUT, making the entire canyons shallower (Figure 7.9-b). After simulating PET with the new scenarios, we found that the new minimum PET would be 23.16 °C, and the new maximum PET would be 24.87 °C (Figure 7.10). Based on the comparison of current PET levels and the new ones, we concluded that decreasing the aspect ratio does not have any significant impact on PET levels in this location. Considering the results of both increasing and decreasing aspect ratios, we can conclude that aspect ratio does not play a significant role in mitigating outdoor thermal discomfort in this research.

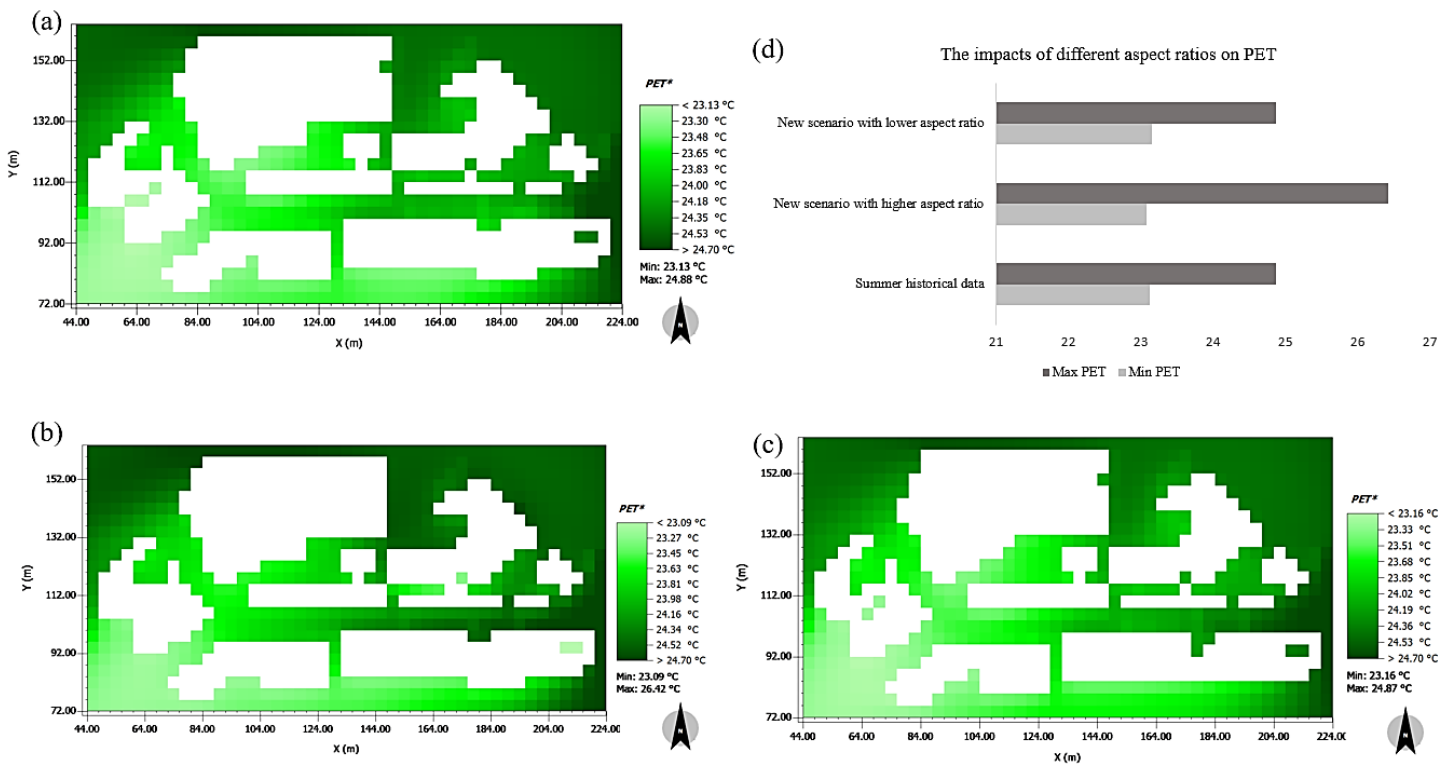

Figure 7.10 (a): The PET level by current aspect ratios, (b): The PET level by increasing aspect ratios, (c): The PET level by decreasing aspect ratios, (d): Comparing the impacts of various aspect ratios on PET

7.4.4.2. Defining new types of urban greenery for assessing the level of outdoor thermal comfort

Increased urban greenery is closely linked to better thermal comfort, especially during heat waves (Salata et al., 2017, Sodoudi et al., 2018). The amount of greenery is limited in the selected location and does not have a significant impact on outdoor thermal comfort. The only greenery consists of young trees located on the northeast side of the area. Therefore, for the second mitigation scenario, we analysed the effects of two types of greenery, namely trees and green walls, on the level of outdoor thermal comfort during summer.

At first, we attempted to analyse the impacts of trees on outdoor thermal comfort in this location. After a detailed analysis of the size of the selected location, the most optimal size for simulating trees was determined to be a width of 2 meters and a height of 5 meters, with 4 meters between them to avoid obstructing pedestrians in the selected location. Therefore, approximately 52 trees were simulated throughout the entire selected location. The features of the trees are as follows: Foliage shortwave albedo: 0.18, Foliage shortwave transmittance: 0.30, Leaf emissivity: 0.96, Leaf emissivity: 0.96 (Figure 7.11-a). The simulation results indicate that with the addition of more trees, the minimum PET will decrease from 23.13 °C in the current situation to 20.56 °C, and the maximum PET will decrease from 24.88 °C in the current situation to 21.5 °C in the new scenario (Figure 7.12). Therefore, trees have a positive impact on the PET level in the selected location, signifying a range of thermal perception within the comfort and neutral range.

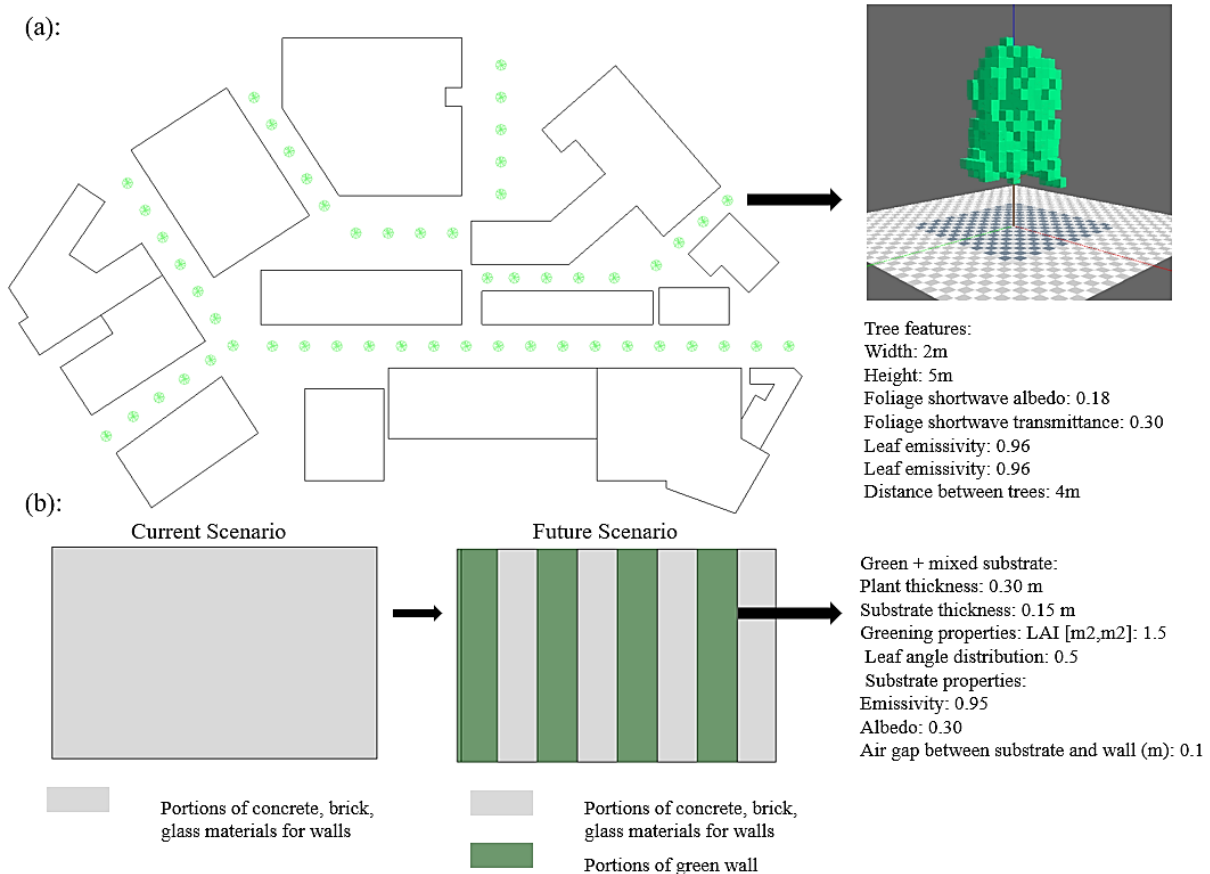

Figure 7.11 (a): Adding trees for analysing the PET level (b): altering 50% of wall's materials with greenery for analysing the PET level

After observing the positive impacts of trees on the range of thermal perception during summer, we opted to analyse the effects of a combination of different types of greenery on outdoor thermal comfort. In addition to the previous scenarios with trees, we introduced green walls. Specifically, we designated 50% of each building façade as a green wall, replacing the traditional wall with vegetation (Figure 7.11-b). The features of the green wall are as follows: Green + mixed substrate, Plant thickness: 0.30 m, Substrate thickness: 0.15 m, Greening properties: LAI [m², m²]: 1.5, Leaf angle distribution: 0.5, Substrate properties: Emissivity: 0.95, Albedo: 0.30, Air gap between substrate and wall (m): 0.10. The simulation results show that with the addition of more trees and green walls, the minimum Physiological Equivalent Temperature (PET) will decrease from 23.13 °C in the current situation to 19.21 °C, and the

maximum PET will decrease from 24.88 °C in the current situation to 20.53 °C in the new scenario (Figure 7.12). These results indicate that this scenario has the most significant impact on mitigating PET levels, providing comfort and a neutral range of thermal perception.

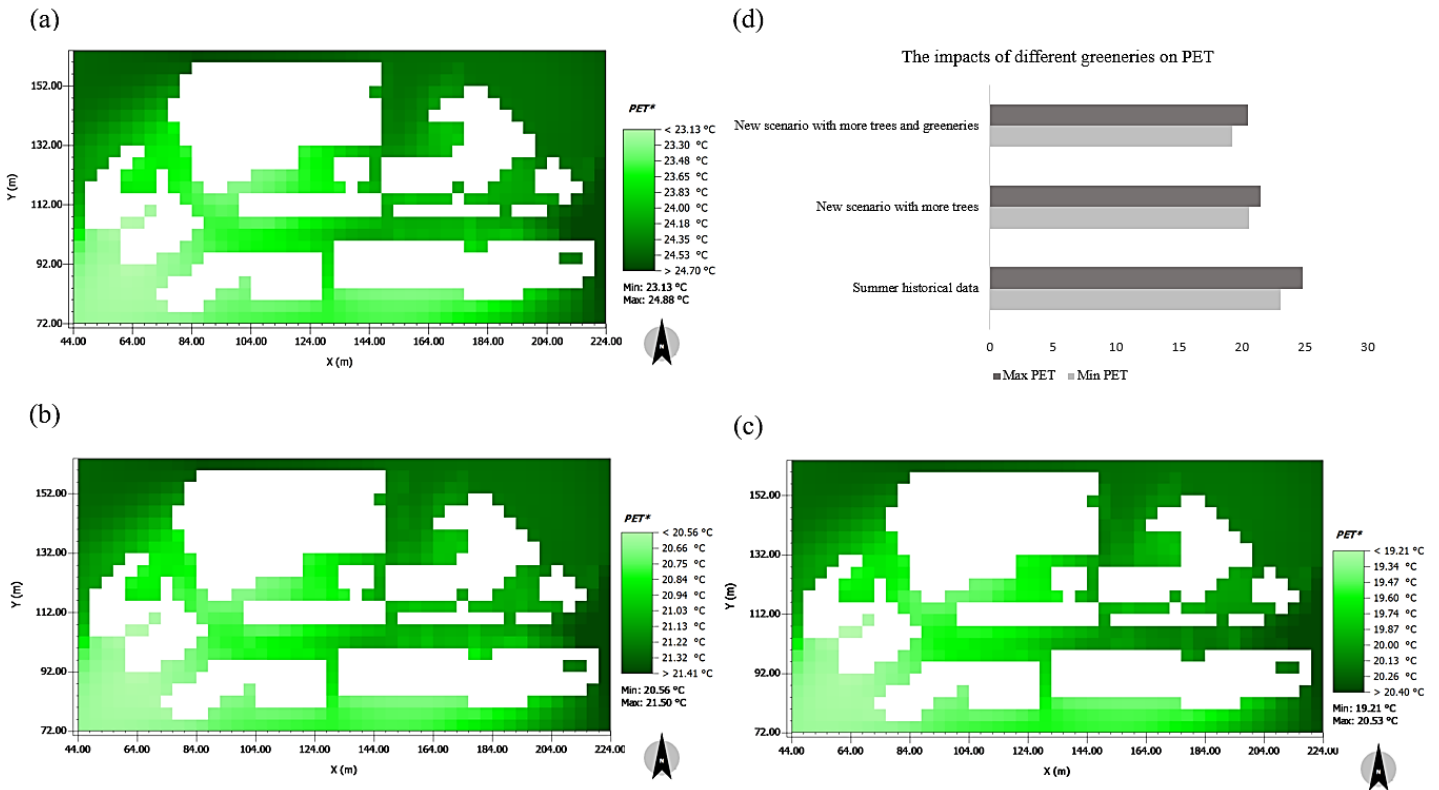

Figure 7.12 The PET level by current aspect ratios, (b) The PET level by adding trees, (c) The PET level by adding trees and green walls, (d) Comparing the impacts of various greeneries on PET

7.5 Limitations of the study and discussion

Outdoor areas play a significant role in urban lives, and providing a comfortable thermal outdoor environment is a key factor in encouraging people to use these spaces. Considering the warning signs of climate change, which appear to have negative impacts on outdoor thermal comfort, this research aimed to analyse the level of outdoor thermal comfort in the selected location of Auckland based on current and predicted future climate patterns. The goal was to define new scenarios to create an outdoor thermal area that was as comfortable as possible. However, based on our results and limitations, there are some significant points that future researchers should consider in their studies:

Firstly, after analysing the agreement between field measurements and Envi-met simulated data, we observed a strong correlation between the measured and simulated data for air temperature and humidity. However, the agreement was not as satisfactory for wind speed compared to air temperature and humidity. These findings align with the results of previous research (Acero & Arrizabalaga, 2018). Therefore, for future studies where wind speed is the primary focus, we recommend comparing the results obtained from Envi-met with those from other Computational Fluid Dynamics (CFD) software to achieve more accurate results.

Secondly, in this research, we analysed the average historical climate conditions of summer and winter to assess the current level of outdoor thermal comfort. To obtain more comprehensive results, future studies could investigate outdoor comfort levels during extreme climate conditions. For example, analysing outdoor thermal comfort on the hottest days based on historical records. Given the predicted climate change in the future, this type of analysis provides us with a broader view of current risk conditions.

Finally, based on the chosen predicted future climate change scenarios in this study, our aim was to devise new urban scenarios to achieve a more comfortable outdoor thermal level. However, our defined scenarios primarily focused on altering aspect ratios and introducing additional greenery. The results indicated the positive impact of greenery on adjusting outdoor thermal comfort levels, a finding supported by scenarios in previous research (Klemm et al., 2015, Wahba et al., 2019, Cui et al., 2022). Nevertheless, it is crucial to recognize that building and pavement materials also play significant roles in outdoor thermal comfort, particularly considering the effects of absorption and reflection. Therefore, analysing the impacts of various materials is a critical factor that warrants attention in future research. The results of examining different materials can serve as an effective approach, especially for new construction designs, ensuring a more sustainable approach from the initial construction phase. Furthermore, in this research, we analysed the new scenarios based on current climate conditions and extended the

positive results of these scenarios to encompass future RCPs. For a more comprehensive understanding in the future, the impacts of the optimal new scenarios can be investigated considering different RCPs and future time slices as well.

7.6 Conclusion

Improving outdoor thermal comfort conditions is critical in creating more healthy and liveable cities and encouraging people to spend more time outdoors. Due to climate change and urban population growth, the quality of urban areas is decreasing. The construction of new urban developments, especially the design of more high-rise buildings and fewer greenery areas, is creating challenging microclimates that negatively impact outdoor thermal comfort conditions. The aim of this study was to explore the influence of current urban design conditions on the outdoor thermal comfort level of Auckland University of Technology, using both historical climate data from 2000 to 2022 and predicted future climate patterns based on RCP 4.5 (a mid-range scenario with greenhouse gas concentrations stabilizing by 2100) and RCP 8.5 (a 'business as usual' scenario with increasing greenhouse gas emissions) for the near future (2040), mid-future (2090), and far future (2110). Finally, the study sought to define new urban design scenarios to decrease the level of outdoor thermal discomfort. Based on the results of this research, we can conclude:

- The Envi-met simulated data's accuracy was evaluated through a comparison with observed meteorological data values, considering that the R-squared value exceeds 0.88 for all factors, Envi-met has been selected as the main software for this research.
- Based on the historical climate data of Auckland from 2000 to 2022 and the current urban design, the selected location experiences slight heat and cold stress during both summer and winter, with a PET level range between 23.13 °C and 24.88 °C in summer and between 13.47 °C and 14.66 °C during winter.

- In this research, analysing future outdoor thermal comfort patterns based on RCP4.5 and RCP8.5 for the near future (2040), mid-future (2090), and far future (2110) indicates that the outdoor thermal comfort range will moderately increase for both scenarios across the three selected time periods for both summer and winter. In the worst-case scenario, the thermal perceptions may reach moderate heat stress in summer by the year 2110 under scenario RCP 8.5, with a PET level of 29.05°C.
- Based on the predicted future climate scenarios, the increasing air temperature suggests that thermal perceptions will transition from slight cold stress to comfortable and neutral conditions during winter.
- In considering new scenarios to mitigate the impacts of climate change and provide comfortable outdoor areas, the results show that the positive impacts of greenery are more significant than changing the aspect ratio in this research. While increasing the aspect ratio could worsen the PET levels, decreasing the aspect ratio does not have any significant impact on PET levels. Greenery has a positive impact on the PET level in the selected location, signifying a range of thermal perceptions within the comfort and neutral range. Given the multiple other co-benefits of greenery for public health and climate change adaptation/mitigation (Sharifi, 2021), it should be prioritized in actions toward improving outdoor thermal comfort.
- Planting trees and replacing 50% of the current wall materials with green walls have the most significant impact on mitigating PET levels, providing comfort and a neutral range of thermal perception.

The approaches and discoveries outlined in this research are anticipated to provide valuable perspectives for urban planners and architects as they evaluate outdoor thermal comfort patterns in different urban settings. These insights can guide the implementation of strategies aimed at improving human comfort, considering anticipated climate change scenarios. Such

initiatives have the potential to enhance the overall liveability of outdoor spaces within urban areas.

Chapter 8 Discussions, Conclusions and Recommendations

8.1 Overview

This chapter reviews the research aim, research objectives, research questions, and significant findings of the study, followed by discussions. The contribution to knowledge is also presented. Limitations and recommendations for future research are discussed at the end of the chapter.

8.2 The Fulfilment of the Research Aim

This research aims to investigate microclimate and outdoor thermal comfort conditions at Auckland University of Technology, New Zealand. To achieve this research aim, 6 objectives were established as follows:

8.2.1 Objective 1: location selection criteria and trends in previous microclimate and outdoor thermal comfort research

The purpose of this objective is to understand and provide insights into the criteria that previous studies considered when selecting a location for microclimate and outdoor thermal analysis. Three aspects of location selection criteria are considered, which also serve as the research questions for this objective. They are as follows: 1) Which locations have been identified as the most widely used in previous studies? 2) How can locations be categorized into single or multiple ones based on the Köppen climate classification, and what are the achievements and recommendations for improving microclimate and outdoor thermal comfort conditions for each category? 3) What is the range of criteria considered for selecting case studies in previous research on microclimate and outdoor thermal comfort?

Chapter 2 provides a comprehensive examination of the most prominent locations in microclimatic studies conducted between 2015 and 2022. The identified typologies, including neighbourhoods, urban streets, universities, parks, squares, and courtyards, underscore the variety of settings crucial for understanding and improving urban microclimates. Despite a

satisfactory exploration of these locations, the chapter highlights the need for future studies to broaden their focus to various other areas. This is essential for enhancing liveability, encouraging outdoor activities, and reducing energy consumption in buildings. The criteria for selecting locations in urban microclimate studies were thoroughly reviewed, revealing a range of considerations. Climate type, period of study, dimension, density, and intensity, along with factors impacting microclimate and outdoor thermal comfort, emerged as crucial elements. Geometry and greenery in high-density temperate climates emerged as the most popular focus in previous studies.

An analysis of microclimate and outdoor thermal comfort studies across different climate classifications, including Tropical (A), Dry (B), Temperate (C), and Continental (D), revealed varied emphases. Studies in temperate climates took precedence, employing greenery and geometry to address the challenges of both hot summers and cold winters. Tropical climates prioritized shading techniques to combat high temperatures, humidity, and heat, while dry climates addressed extreme temperature fluctuations and drought. Continental climates saw mitigation strategies through building geometries, vegetation, and cool pavements. Summarily, there is a noticeable scarcity of studies in climate types beyond temperate (Csa). Neglected areas, like Am climates, warrant attention. Future researchers are urged to broaden their scope, considering the predicted climate change, urban heat island effects, and population growth. To address identified gaps, recommendations for future research include exploring multiple locations, expanding the period of study to include cold periods, focusing on smaller areas, and emphasizing the significance of materials. Parameters like geometry, greenery, and outdoor/semi-outdoor designs should be further investigated, and attention to density/intensity variations is crucial for comprehensive urban microclimate studies.

8.2.2 Objective 2: An assessment of existing microclimate and outdoor thermal comfort studies in temperate oceanic (Cfb) cities

The purpose of this objective is to understand and provide insights into previous research on microclimate and outdoor thermal comfort in temperate oceanic (Cfb) cities. Three criteria are considered, which also serve as the research questions for this objective. They are as follows:

1) What is the current overview of existing studies on urban microclimate and outdoor thermal comfort in Cfb cities? 2) What gaps have been identified in urban microclimate studies within Cfb cities? 3) What recommendations are proposed for addressing neglected but critical aspects of urban microclimate in future studies within Cfb cities?

Chapter 3 critically reviews microclimatic studies in Cfb (temperate oceanic) cities. The findings expose a research gap, with fewer than 45 publications meeting the set criteria for over 50 Cfb cities worldwide. Only 17 Cfb cities are represented, averaging fewer than 3 papers per city. This scarcity underscores the need for more comprehensive investigations in Cfb cities, making the development of a comprehensive guideline challenging at this stage. However, the analysis of selected papers offers crucial recommendations for future researchers in Cfb cities. Key findings emphasize strategies to mitigate thermal stress and enhance outdoor comfort. These include the importance of increasing greenery, particularly trees, and understanding the significant impact of trees on reducing air temperature through evapotranspiration and shading effects. This chapter also highlights the need to explore the impacts of façade greenery on mean radiant temperature and the utilization of lightweight materials to decrease thermal stress.

The identified gaps in previous research pave the way for specific recommendations to address shortcomings and provide a comprehensive microclimatic guideline. Future studies should extend beyond residential areas and urban streets, exploring commercial areas, urban parks, squares, and universities to create comfortable outdoor spaces and enhance overall liveability. While greenery is crucial, future research should consider materials and geometry alongside

greenery for a more accurate understanding of microclimatic conditions. This includes a deeper exploration of the impacts of materials, aspect ratio, and street orientation on outdoor thermal comfort. A combination of field measurements and computer modelling is advocated for more effective microclimate studies. While field measurements offer real-time insights, computer modelling provides a holistic understanding, aiding in the development of future climate-sensitive urban designs.

The predominant focus on summer in existing studies prompts the recommendation to extend considerations to winter conditions. Investigating the impact of local climate warming during winter and assessing potential benefits, including reduced heating energy requirements, will contribute significantly to design strategies.

8.2.3 Objective 3: Analysing previous microclimate and outdoor thermal comfort studies in Australia and New Zealand

The purpose of this objective is to understand and provide insights into previous research on microclimate and outdoor thermal comfort in Australia and New Zealand. Three criteria are considered, which also serve as the research questions for this objective. They are as follows:

1) What is the analysis of previous research on urban microclimate and outdoor thermal comfort in Australia and New Zealand? 2) What gaps have been identified in studies on outdoor thermal comfort and urban microclimate in Australia and New Zealand? 3) What recommendations are proposed for addressing neglected but critical aspects of urban microclimate in future studies within Australia and New Zealand?

Chapter 4 reveals a limited body of research on microclimatic and outdoor thermal comfort studies in Australia and New Zealand. Predominantly, the reviewed papers focused on the analysis of people's thermal perceptions in residential areas during the summer, relying heavily on field measurements and surveys. However, in Australia, the concentration of studies in cities

like Melbourne and Sydney with temperate climates leaves a gap in our understanding, necessitating a broader analysis of microclimate conditions in various cities, including those typically neglected, such as Darwin, characterized by high humidity and heavy rainfall. Conversely, the study of New Zealand's microclimate and outdoor thermal comfort faces challenges due to a scarcity of research, the neglect of urban morphology effects, and a lack of focus on Central Business Districts (CBDs). Previous studies have fallen short in providing solutions to mitigate the effects of wind speed, rainfall, and the impacts of urban contexts on microclimate conditions.

Moreover, Chapter 4 underscores the limited scope of previous studies concerning key research elements, including study areas, factors analysed, methods utilized, and the study period. Firstly, there is a noticeable dearth of research on outdoor urban places that play a significant role in people gathering, such as commercial areas, urban parks, squares, and universities. While residential neighbourhoods and urban streets have been reasonably studied, a comprehensive understanding necessitates exploring these other urban spaces. Secondly, approximately half of the previous studies focused on people's outdoor thermal perceptions, overlooking the critical influence of urban configurations on thermal sensations. A broader analysis of different factors is essential for more accurate results. Thirdly, a significant portion of selected papers relied on field measurements and surveys, emphasizing the need for a more effective approach involving a combination of field measurements, surveys, and computer modelling for studying microclimates. Lastly, despite the relatively mild climatic conditions in Australia and New Zealand, nearly 50% of studies concentrated on summer, emphasizing the importance of extending considerations to winter. This shift is crucial for understanding thermal comfort during winter, contributing to the design of buildings and outdoor spaces that are comfortable and energy-efficient throughout the year.

In conclusion, past studies in Australia and New Zealand have underscored the pivotal role of greenery in improving microclimatic conditions and outdoor thermal comfort, particularly in summer. Future research should delve into how greenery can effectively counter the impacts of climate change on outdoor thermal comfort in urban contexts. Moreover, significant gaps persist in our understanding of the effects of urban geometry and materials on microclimatic conditions and outdoor thermal comfort in current and future settings, demanding attention in future research endeavours. Considering the present and predicted climate patterns in these countries, addressing climatic challenges in urban design to enhance outdoor thermal comfort year-round is imperative.

8.2.4 Objective 4: Identify outdoor thermal risk areas

The purpose of this objective is to understand and provide insights into the identification of outdoor thermal risk areas in the context of Auckland University of Technology. Four criteria are considered, which also serve as the research questions for this objective. They are as follows: 1) What are the best ways to define the three different layers of hazard, exposure, and vulnerability? 2) Which methods should be employed to determine the specific layers of hazard, exposure, and vulnerability? 3) What future scenarios can be derived based on predicted climate change in high thermal risk areas? 4) What improvement scenarios can help alleviate thermal stress in high-risk thermal areas?

In Chapter 5, the focus shifted to the identification of thermal risk areas within the city campus of Auckland University of Technology in New Zealand. The analysis concentrated on a specific timeframe (12:00 to 13:00) on the 14th and 15th of March 2023. Beyond pinpointing these risk areas, the chapter aimed to delve into the future thermal patterns by simulating the Physiologically Equivalent Temperature (PET) for the summers of 2050 and 2080. Additionally, the chapter sought to propose innovative scenarios for optimizing thermal stress in these identified areas.

Following the identification of thermal risk areas through the overlay of three layers, the chapter incorporated future climate data to predict PET conditions. The projections unveiled an escalation in thermal stress, with location one's projected PET reaching 24.39°C in 2050 and 26.45°C in 2080. Similarly, location two exhibited an increase, with PET projected to reach 25.58°C in 2050 and 27.69°C in 2080. Subsequently, the chapter explored new scenarios for these locations, introducing greenery to mitigate thermal stress. Results showcased the effectiveness of these interventions, such as replacing a concrete wall with a green wall in location one, resulting in an average PET reduction of 2°C (decreasing from 22°C to 20°C). In location two, planting trees led to an average PET reduction of 3°C (decreasing from 25°C to 22°C). In summary, while the assessment of outdoor thermal comfort has been a prevalent research focus, Chapter 5 uniquely aimed to identify thermal risk areas, considering both high thermal stress locations and the reported discomfort of individuals within those areas. Acknowledging the implications of predicted climate change, the study emphasized the need for proactive measures in frequently used outdoor spaces susceptible to thermal risks.

Key conclusions drawn from the research include the anticipation of higher thermal stress in identified risk areas under current and future scenarios, with a projected increase of approximately 2°C in 2050 and 4°C in 2080. The simulation results also suggest an expected rise in the number of outdoor thermal risk areas in Auckland during future summers. Questionnaire results highlighted the significance of age group and nationality as predictors of thermal sensation, emphasizing the need for tailored interventions. Furthermore, insights from the questionnaires underscored that high wind speed, alongside air temperature, contributes to discomfort in outdoor spaces during summer, warranting additional analysis in future studies. Lastly, the simulation outcomes underscored the impactful role of greenery, specifically trees and green walls, in reducing PET levels and enhancing outdoor thermal comfort in Auckland's

identified thermal risk areas during summer. Future researchers are encouraged to explore and leverage greenery to optimize urban outdoor thermal conditions.

8.2.5 Objective 5: Analysing the impact of the most challenging climate factor, namely wind speed, on the pedestrian level of comfort

The purpose of this objective is to understand and provide insights into the impacts of wind speed on pedestrian comfort in the context of Auckland University of Technology. Four criteria are considered, which also serve as the research questions for this objective. They are as follows: 1) What are the public perceptions of wind speeds during both summer and winter? 2) What is the average wind speed, based on historical data, in micro-scale urban areas using computational fluid dynamics? 3) What are the impacts of urban design elements, namely street orientations, aspect ratios, and building arrangements, on wind speed at the pedestrian level? 4) How can we design comfort criteria based on wind speed for specific locations to assess the level of pedestrian comfort under different wind speed conditions?

Chapter 6 delves into a comprehensive analysis of wind speeds at Auckland University of Technology (AUT), focusing on different time periods and various building aspect ratios across four distinct locations, further divided into 12 zones. The study employs a combination of field surveys, including questionnaires, and software simulations using ANSYS to discern both people's sensations and the range of wind speeds at AUT.

The key findings of the analysis shed light on critical factors influencing wind comfort criteria. Notably, street orientations, especially those at a 45-degree angle to prevailing winds, emerge as the most influential in assessing wind challenges, surpassing the impact of building arrangements and aspect ratios. Streets parallel to predominant winds exhibit fewer wind challenges, emphasizing the prioritization of street orientations in wind speed analyses. Building arrangements gain significance in challenging areas, particularly in designing high-

rise buildings at the street's edge facing predominant winds, effectively mitigating intense winds.

Aspect ratio, a critical variable in wind speed patterns, showcases distinct influences in various directions and locations. The study underscores the importance of analysing diverse orientations before considering aspect ratio impact. The correlation between wind speed and aspect ratio within the same location is evident, with deeper aspect ratios linked to increased wind speed. Additionally, the geometry of the ratio becomes crucial, revealing that among areas with similar aspect ratios, greater width contributes to reduced wind speeds.

Conclusions drawn from the research encompass significant insights into the experiences of survey participants, with over 55% reporting windy conditions in both summer and winter. Correlating survey results with the Beaufort Scale, areas with wind speeds below 3.3 m/s were deemed comfortable, while speeds exceeding 3.4 m/s were categorized as high-risk areas. The most challenging conditions are associated with north-east winds during the summer, affecting seven zones. In Location 1, the zone with an aspect ratio of 1.3 stands out as the area with the highest wind speed hazard at AUT.

The optimal scenario for achieving tolerable wind speeds involves reducing aspect ratios in high-risk zones in Location 1, aligning with previous studies aimed at decreasing wind speeds in diverse urban contexts. ANSYS simulations underscore that similar aspect ratios can yield varying wind speed patterns during comparable time periods, emphasizing the intricate interplay of location orientation, wind directions, building arrangements, and aspect ratio shapes in understanding the impact of urban designs on wind speeds.

8.2.6 Objective 6: Analysing the impacts of historical and future climate change projections on the outdoor thermal comfort patterns of Auckland, New Zealand

The purpose of this objective is to understand and provide insights into the impacts of historical and future climate change projections on outdoor thermal comfort patterns in the context of Auckland University of Technology. Three criteria are considered, which also serve as the research questions for this objective. They are as follows: 1) How can outdoor thermal comfort patterns be analysed based on historical data of Auckland for both summer and winter? 2) What are the projected future thermal comfort patterns for Auckland in the near future (2040), mid-future (2090), and far future (2110) based on RCP 4.5 and RCP 8.5, considering both summer and winter? 3) What are the various mitigation scenarios that can be defined to decrease thermal discomfort?

Chapter 7 extensively explores the intricate interplay between current urban design conditions and outdoor thermal comfort at Auckland University of Technology (AUT). Drawing on historical climate data spanning 2000 to 2022 and prognostications based on RCP 4.5 and RCP 8.5 scenarios for the near future (2040), mid-future (2090), and far future (2110), the chapter aims to delineate new urban design scenarios capable of alleviating outdoor thermal discomfort. The accuracy of Envi-met simulated data, crucial for this research, underwent rigorous evaluation by comparing it with observed meteorological data values. The robustness of Envi-met is affirmed, given its R-squared value surpassing 0.88 for all factors.

Analysis of historical climate data unveils that, under the prevailing urban design, the selected location experiences slight heat and cold stress during both summer and winter. The PET level fluctuates between 23.13 °C and 24.88 °C in summer and between 13.47 °C and 14.66 °C during winter. Future-oriented investigations, under RCP 4.5 and RCP 8.5 scenarios, forecast a moderate increase in the outdoor thermal comfort range across the three selected time periods

for both summer and winter. Notably, in the worst-case scenario (RCP 8.5), thermal perceptions may escalate to moderate heat stress by 2110, registering a PET level of 29.05°C.

As climate scenarios predict an ascent in air temperature, the transition from slight cold stress to comfortable and neutral conditions during winter becomes a discernible trend in thermal perceptions. In the pursuit of new scenarios to counter the impacts of climate change and craft congenial outdoor spaces, the study discerns that greenery exerts a more potent influence than alterations in aspect ratio. Increasing the aspect ratio tends to exacerbate PET levels, whereas decreasing it shows no substantial impact. Greenery emerges as a positive force, fostering a range of thermal perceptions within the comfort and neutral spectrum. The study advocates prioritizing greenery, especially the strategic planting of trees and the replacement of 50% of current wall materials with green walls, as the most effective measures for mitigating PET levels and enhancing outdoor thermal comfort. Beyond these benefits, the multifaceted advantages of greenery for public health and climate change adaptation underscore its paramount importance in shaping actions to enhance outdoor thermal comfort.

8.3 Contribution and Significance of the Research

This comprehensive research undertaken at Auckland University of Technology (AUT) in New Zealand significantly contributes to the understanding of urban microclimates, outdoor thermal comfort, and the impacts of climate change on these factors. The study systematically addresses various aspects, providing valuable insights and practical recommendations for future urban planning and design.

The research findings are particularly relevant in informing urban design standards and policies, such as the New Zealand Urban Design Protocol and the Resource Management Act, which emphasize the creation of liveable and sustainable urban spaces. By demonstrating the critical role of greenery, such as trees and green walls, in mitigating thermal stress, the research

supports existing guidelines that advocate for increased urban greening. For example, the findings align with the principles of Green Infrastructure policies, which prioritize the integration of vegetation to manage environmental stresses in urban areas.

The exploration of wind speeds and the impact of street orientations and building arrangements provides valuable insights for pedestrian comfort standards. These findings suggest the need for updated guidelines that reflect the local climatic conditions and urban morphology in temperate oceanic cities like Auckland, ensuring that design interventions are both context-specific and climate-responsive.

Furthermore, the research highlights the importance of considering future climate scenarios in urban planning. This supports the integration of climate resilience measures into planning documents, such as Auckland's Climate Action Plan and New Zealand's National Adaptation Plan, which aim to reduce the risks posed by climate change through informed design decisions.

The recommendations for future research, which include investigating various urban spaces and considering seasonal variations, reinforce the need for a broader and more inclusive approach to outdoor thermal comfort assessment. This aligns with international standards like ISO 7730, which provides guidance on thermal comfort in buildings but can be extended to include outdoor spaces under changing climatic conditions.

In conclusion, the research not only advances academic knowledge but also provides actionable insights for urban planners, designers, and policymakers. By linking its findings to existing frameworks, the study offers practical guidance for shaping future urban spaces to be more climate-sensitive, comfortable, and sustainable.

8.4 Research Limitations and Recommendations for Future Research

The scope of the research is limited to Auckland, New Zealand. Therefore, the results of the research should be reanalysed to be adapted for other cities in New Zealand and other countries. Temperate oceanic (Cfb) cities could learn lessons from each other due to their similar climate patterns and, at times, comparable climate challenges. In the following, the limitations in different chapters of this study have been explained in more detail.

In Chapter 5, it is essential to acknowledge a limitation of this investigation, which centres around its narrow focus on a specific hour during a summer day to identify outdoor thermal risk areas within the chosen location. To overcome this limitation, future efforts should involve expanding the research scope to cover more extended time periods, assessing thermal risks during both hot and cold periods. This expansion entails conducting PET simulations over multiple days to identify areas of thermal discomfort. Moreover, future research should enhance data collection by involving a larger and more diverse group of participants, enabling the development of comprehensive exposure and vulnerability layers for a more thorough understanding of thermal risks.

While Chapter 5 primarily emphasizes assessing thermal risks during hot periods, subsequent investigations will extend to examining future climate scenarios, encompassing both hot and cold periods. This comprehensive approach will aid researchers in understanding the varying dynamics of thermal discomfort in different climatic conditions. Additionally, Chapter 5's focus on defining new scenarios revolves around investigating the impact of greenery in mitigating outdoor thermal risks. However, future research should explore a wider range of scenarios, aiming to identify the most optimal approaches for mitigating thermal risks. It is crucial to emphasize that the current scenario presented in Chapter 5 serves as a preliminary suggestion and should not be considered the definitive or ideal solution.

In Chapter 6, the high accuracy of CFD in simulating wind speeds has been validated for Auckland University of Technology. For more comprehensive results, future research should consider employing Ansys in different urban contexts. However, Ansys Fluent is suitable for modelling various fluid flow phenomena but has limitations when simulating vegetation, particularly trees. In Chapter 6, due to the limited number of young trees located away from the main areas, they have been represented as simple shapes with real height and width in simulations. Nevertheless, in locations with a significant number of trees, where factors like leaf properties, dynamic growth, and seasonal changes are important, Ansys may have limitations. The accuracy of wind speed simulations under these conditions should be validated in future research. Furthermore, the results regarding the impacts of orientations, building arrangements, and aspect ratios on wind speed are derived from the analysis of the AUT City Campus in Auckland. To gain a more comprehensive understanding, future researchers should analyse these factors in various urban contexts.

In Chapter 7, there are significant points that future researchers should consider: Firstly, after analysing the agreement between field measurements and Envi-met simulated data, a strong correlation between the measured and simulated data for air temperature and humidity was observed. However, the agreement was not as satisfactory for wind speed compared to air temperature and humidity. Therefore, for future studies where wind speed is the primary focus, we recommend comparing the results obtained from Envi-met with those from other Computational Fluid Dynamics (CFD) software to achieve more accurate results. Secondly, in Chapter 7, the average historical climate conditions of summer and winter to assess the current level of outdoor thermal comfort were analysed. For more comprehensive results, future studies could investigate outdoor comfort levels during extreme climate conditions, such as analysing outdoor thermal comfort on the hottest days based on historical records. Given the predicted climate change in the future, this type of analysis provides a broader view of current risk

conditions. Finally, based on the chosen predicted future climate change scenarios in this chapter, the aim was to devise new urban scenarios to achieve a more comfortable outdoor thermal level. However, the defined scenarios primarily focused on altering aspect ratios and introducing additional greenery. The results indicated the positive impact of greenery on adjusting outdoor thermal comfort levels. Nevertheless, it is crucial to recognize that building and pavement materials also play significant roles in outdoor thermal comfort, particularly considering the effects of absorption and reflection. Therefore, analysing the impacts of various materials is a critical factor that warrants attention in future research. The results of examining different materials can serve as an effective approach, especially for new construction designs, ensuring a more sustainable approach from the initial construction phase. Furthermore, in Chapter 7, the new scenarios based on current climate conditions and extended the positive results of these scenarios to encompass future RCPs were analysed. For a more comprehensive understanding in the future, the impacts of the optimal new scenarios can be investigated considering different RCPs and future time slices as well.

References

- Abaas, Z. R. (2020). Impact of development on Baghdad's urban microclimate and human thermal comfort. *Alexandria Engineering Journal* 59(1): 275-290. <https://doi.org/10.1016/j.aej.2019.12.040>
- Abd Elraouf, R., Elmokadem, A., Megahed, N., Eleinen, O., & Eltarabily, S. (2022). The impact of urban geometry on outdoor thermal comfort in a hot-humid climate. *Building and Environment* 225: 109632. <https://doi.org/10.1016/j.buildenv.2022.109632>

- Abd Razak, A., Hagishima, A., Ikegaya, N., & J. Tanimoto. (2013). Analysis of airflow over building arrays for assessment of urban wind environment. *Building and Environment* 59: 56-65. <https://doi.org/10.1016/j.buildenv.2012.08.007>
- Abdi, B., Hami, A., & Zarehaghi, D. (2020). Impact of small-scale tree planting patterns on outdoor cooling and thermal comfort. *Sustainable Cities and Society* 56: 102085. <https://doi.org/10.1016/j.scs.2020.102085>
- Abdollahzadeh, N., & Bioria, N. (2021). Outdoor thermal comfort: Analyzing the impact of urban configurations on the thermal performance of street canyons in the humid subtropical climate of Sydney. *Frontiers of Architectural Research* 10(2): 394-409. <https://doi.org/10.1016/j.foar.2020.11.006>
- Abdollahzadeh, N., & Bioria, N. (2022). Urban microclimate and energy consumption: A multi-objective parametric urban design approach for dense subtropical cities. *Frontiers of Architectural Research* 11(3): 453-465. <https://doi.org/10.1016/j.foar.2022.02.001>
- Abu-Hamdeh, N. H., & Alnefaie, K. A. (2019). Assessment of thermal performance of PCM in latent heat storage system for different applications. *Solar Energy* 177: 317-323. <https://doi.org/10.1016/j.solener.2018.11.035>
- Abu-Zidan, Y., Mendis, P., & Gunawardena, T. (2021). Optimising the computational domain size in CFD simulations of tall buildings. *Heliyon* 7(4). <https://doi.org/10.1016/j.heliyon.2021.e06723>
- Acero, J. A., & Arrizabalaga, J. (2018). Evaluating the performance of ENVI-met model in diurnal cycles for different meteorological conditions. *Theoretical and Applied Climatology* 131: 455-469. <https://doi.org/10.1007/s00704-016-1971-y>
- Acero, J. A., Koh, E., Li ,X., Ruefenacht, L., Pignatta, G., & Norford, L. K. (2019). Thermal impact of the orientation and height of vertical greenery on pedestrians in a tropical area. *Building Simulation*, 12: 973–984. <https://doi.org/10.1007/s12273-019-0537-1>
- Acero, J. A., Koh, E., Pignatta, G., & Norford, L. K. (2020). Clustering weather types for urban outdoor thermal comfort evaluation in a tropical area. *Theoretical and Applied Climatology* 139(1-2): 659-675. <https://doi.org/10.1007/s00704-019-02992-9>
- Acero, J. A., Koh, E., L. Ruefenacht, A., & Norford, L. K. (2021). Modelling the influence of high-rise urban geometry on outdoor thermal comfort in Singapore. *Urban Climate* 36: 100775. <https://doi.org/10.1016/j.uclim.2021.100775>
- Achour-Younsi, S., & Kharrat, F. (2016). Outdoor thermal comfort: impact of the geometry of an urban street canyon in a Mediterranean subtropical climate—case study Tunis, Tunisia.

<https://doi.org/10.1016/j.sbspro.2015.12.062>

Aflaki, A., Mirnezhad, M., Ghaffarianhoseini, A., Ghaffarianhoseini, A., Omrany, H., Wang, Z.-H., & Akbari, H. (2017). Urban heat island mitigation strategies: A state-of-the-art review on Kuala Lumpur, Singapore and Hong Kong. *Cities* 62: 131-145.

<https://doi.org/10.1016/j.cities.2016.09.003>

Aghamolaei, R., Azizi, M. M., Aminzadeh, B., & Mirzaei, P. A. (2020). A tempo-spatial modelling framework to assess outdoor thermal comfort of complex urban neighbourhoods. *Urban Climate* 33: 100665.

<https://doi.org/10.1016/j.uclim.2020.100665>

Aghamolaei, R., Azizi, M. M., Aminzadeh, B., & O'Donnell, J. (2023). A comprehensive review of outdoor thermal comfort in urban areas: Effective parameters and approaches. *Energy & Environment* 34(6): 2204-2227.

<https://doi.org/10.1177/0958305X221116176>

Aghamolaei, R., Fallahpour, M., & Mirzaei, P. A. (2021). Tempo-spatial thermal comfort analysis of urban heat island with coupling of CFD and building energy simulation. *Energy and Buildings* 251: 111317.

<https://doi.org/10.1016/j.enbuild.2021.111317>

Aghamolaei, R., & Lak, A. (2023). Outdoor thermal comfort for active ageing in urban open spaces: reviewing the concepts and parameters. *Ageing International* 48(2): 438-451.

<https://doi.org/10.1007/s12126-022-09482-w>

Ahmad, K., Khare, M., & Chaudhry, K. (2005). Wind tunnel simulation studies on dispersion at urban street canyons and intersections—a review. *Journal of Wind Engineering and Industrial Aerodynamics* 93(9): 697-717.

<https://doi.org/10.1016/j.jweia.2005.04.002>

Ahmadian, E., Sodagar, B., & Bingham, C. A. Elnokaly and G. Mills (2021). Effect of urban built form and density on building energy performance in temperate climates. *Energy and Buildings* 236: 110762.

<https://doi.org/10.1016/j.enbuild.2021.110762>

Akbari, H., & Kolokotsa, D. (2016). Three decades of urban heat islands and mitigation technologies research. *Energy and Buildings* 133: 834-842.

<https://doi.org/10.1016/j.enbuild.2016.09.067>

Aksu, G. A., & Küçük, N. (2020). Evaluation of urban topography–biotope–population density relations for Istanbul–Beşiktaş urban landscape using AHP. *Environment, Development and Sustainability* 22(2): 733-758.

<https://doi.org/10.1007/s10668-018-0217-9>

Alavipanah, S., Wegmann, M., Qureshi, S., Weng, Q., & Koellner, T. (2015). The role of vegetation in mitigating urban land surface temperatures: A case study of Munich, Germany during the warm season. *Sustainability* 7(4): 4689-4706.

<https://doi.org/10.3390/su7044689>

- Albdour, M. S., & Baranyai, B. (2019). An overview of microclimate tools for predicting the thermal comfort, meteorological parameters and design strategies in outdoor spaces. *Pollack Periodica* 14(2): 109-118. <https://doi.org/10.1556/606.2019.14.2.10>
- Ali-Toudert, F., & Mayer, H. (2006). Numerical study on the effects of aspect ratio and orientation of an urban street canyon on outdoor thermal comfort in hot and dry climate. *Building and Environment* 41(2): 94-108. <https://doi.org/10.1016/j.buildenv.2005.01.013>
- Ali-Toudert, F., & Mayer, H. (2007). Thermal comfort in an east–west oriented street canyon in Freiburg (Germany) under hot summer conditions. *Theoretical and applied climatology* 87(1): 223-237. <https://doi.org/10.1007/s00704-005-0194-4>
- Ali, S., & Li, B. (2018). Evaluating the impact of the morphological transformation of urban sites on the urban thermal microenvironment. *Buildings* 8(12): 182. <https://doi.org/10.3390/buildings8120182>
- Ali, S. B., & Patnaik, S. (2019). Assessment of the impact of urban tree canopy on microclimate in Bhopal: A devised low-cost traverse methodology. *Urban Climate* 27: 430-445. <https://doi.org/10.1016/j.uclim.2019.01.004>
- Allegrini, J., & Carmeliet, J. (2018). Simulations of local heat islands in Zürich with coupled CFD and building energy models. *Urban Climate* 24: 340-359. <https://doi.org/10.1016/j.uclim.2017.02.003>
- Allegrini, J., Dorer, V., & Carmeliet, J. (2015). Coupled CFD, radiation and building energy model for studying heat fluxes in an urban environment with generic building configurations. *Sustainable Cities and Society* 19: 385-394. <https://doi.org/10.1016/j.scs.2015.07.009>
- Allison, P. (2013). What's the best R-squared for logistic regression. *Statistical Horizons* 13.
- Almeida, C. R. d., Teodoro, A. C., & Gonçalves, A. (2021). Study of the Urban Heat Island (UHI) Using Remote Sensing Data/Techniques: A Systematic Review. *Environments* 8(10): 105. <https://doi.org/10.3390/environments8100105>
- Alsaad, H., Hartmann, M., Hilbel, R., & Voelker, C. (2022). The potential of facade greening in mitigating the effects of heatwaves in Central European cities. *Building and Environment* 216: 109021. <https://doi.org/10.1016/j.buildenv.2022.109021>
- Altunkasa, C., & Uslu, C. (2020). Use of outdoor microclimate simulation maps for a planting design to improve thermal comfort. *Sustainable Cities and Society* 57: 102137. <https://doi.org/10.1016/j.scs.2020.102137>
- Alvarez, I., Quesada-Ganuz, a L., Briz, E., & Garmendia, L. (2021). Urban heat islands and thermal comfort: A case study of Zorrotzaurre island in Bilbao. *Sustainability* 13(11): 6106. <https://doi.org/10.3390/su13116106>

- Amindeldar, S., Heidari, S., & Khalili, M. (2017). The effect of personal and microclimatic variables on outdoor thermal comfort: A field study in Tehran in cold season. *Sustainable Cities and Society* 32: 153-159. <https://doi.org/10.1016/j.scs.2017.03.024>
- Aminipouri, M., Rayner, D., Lindberg, F., Thorsson, S., Knudby, A. J., Zickfeld, K., Middel, A., & Krayenhoff, E. S. (2019). Urban tree planting to maintain outdoor thermal comfort under climate change: The case of Vancouver's local climate zones. *Building and Environment* 158: 226-236. <https://doi.org/10.1016/j.buildenv.2019.05.022>
- Andreou, E. (2013). Thermal comfort in outdoor spaces and urban canyon microclimate. *Renewable Energy* 55: 182-188. <https://doi.org/10.1016/j.renene.2012.12.040>
- Aprada, C., Reder, A., & Mercogliano, P. (2020). Urban morphology parameterization for assessing the effects of housing blocks layouts on air temperature in the Euro-Mediterranean context. *Energy and Buildings* 223: 110171. <https://doi.org/10.1016/j.enbuild.2020.110171>
- Aflaki, A., Mirnezhad, M., Ghaffarianhoseini, A., Ghaffarianhoseini, A., Omrany, H., Wang, Z., Akbari, M. (2017). Urban heat island mitigation strategies: A state-of-the-art review on Kuala Lumpur, Singapore and Hong Kong. *Cities* 62: 131-145. <https://doi.org/10.1016/j.cities.2016.09.003>
- Arkon, C. A., & Özkol, Ü. (2014). Effect of urban geometry on pedestrian-level wind velocity. *Architectural Science Review* 57(1): 4-19. <https://doi.org/10.1080/00038628.2013.835709>
- Armstrong, B. G., & Sloan, M. (1989). Ordinal regression models for epidemiologic data. *American Journal of Epidemiology* 129(1): 191-204. <https://doi.org/10.1093/oxfordjournals.aje.a115109>
- Ashraf, S., AghaKouchak, A., Nazemi, A., Mirchi, A., Sadegh, M., Moftakhari, H. R., Hassanzadeh, E., Miao, C.-Y., Madani, K., & Baygi, M. M. (2019). Compounding effects of human activities and climatic changes on surface water availability in Iran. *Climatic Change* 152(3): 379-391. <https://doi.org/10.1007/s10584-018-2336-6>
- Aydin, E. E., Jakubiec, J. A., & Jusuf, S. K. (2019, September 2-4). *A comparison study of simulation-based prediction tools for air temperature and outdoor thermal comfort in a tropical climate*. Building Simulation Conference Proceedings, 16th Conference of IBPSA, Rome, Italy.
- Azevedo, I., & Leal, V. M. (2017). Methodologies for the evaluation of local climate change mitigation actions: A review. *Renewable and Sustainable Energy Reviews* 79: 681-690. <https://doi.org/10.1016/j.rser.2017.05.100>
- Bai, X., McPhearson, T., Cleugh, H., Nagendra, H., Tong, X., Zhu, T., & Zhu, Y.-G. (2017). Linking urbanization and the environment: Conceptual and empirical advances. *Annual Review*

of *Environment and Resources* 42: 215-240. <https://doi.org/10.1146/annurev-environ-102016-061128>

Balany, F., Muttill, N., Muthukumaran, S., Wong, M. S., & Ng, A. W. (2022). Studying the effect of blue-green infrastructure on microclimate and human thermal comfort in melbourne's central business district. *Sustainability* 14(15): 9057. <https://doi.org/10.3390/su14159057>

Bande, L., Adan, R., Young, K., Ghazal, R., Jha, M., Aldarmaki, A., Aldhaheeri, A., Alneyadi, A., Aldhaheeri, S., & Khalifa, M. (2021). Outdoor Thermal Comfort Study on a District Level as Part of the Housing Programs in Abu Dhabi and Al Ain, United Arab Emirates. *Land* 10(3): 264. <https://doi.org/10.3390/land10030264>

Banerjee, S., & Chattopadhyay, S. (2020). A meta-analytical review of outdoor thermal comfort research: Applications, gaps and a framework to assess low-income settlements in Indian megacities. *Urban Climate* 33: 100641. <https://doi.org/10.1016/j.uclim.2020.100641>

Banerjee, S., Middel, A., & Chattopadhyay, S. (2020). Outdoor thermal comfort in various microentrepreneurial settings in hot humid tropical Kolkata: Human biometeorological assessment of objective and subjective parameters. *Science of The Total Environment* 721: 137741. <https://doi.org/10.1016/j.scitotenv.2020.137741>

Banerjee, S., Middel, A., & Chattopadhyay, S. (2022). A regression-based three-phase approach to assess outdoor thermal comfort in informal micro-entrepreneurial settings in tropical Mumbai. *International Journal of Biometeorology* 66(2): 313-329. <https://doi.org/10.1007/s00484-021-02136-7>

Banerjee, S., Yik, S. K., Dzyuban, Y., Crank, P. J., X, R., Yi, P., & Chow, W. T. (2022). Analysing impacts of urban morphological variables and density on outdoor microclimate for tropical cities: A review and a framework proposal for future research directions. *Building and Environment*: 109646. <https://doi.org/10.1016/j.buildenv.2022.109646>

Baniassadi, A., Sailor, D. J., Crank, P. J., & Ban-Weiss, G. A. (2018). Direct and indirect effects of high-albedo roofs on energy consumption and thermal comfort of residential buildings. *Energy and Buildings* 178: 71-83. <https://doi.org/10.1016/j.enbuild.2018.08.048>

Baquero, M. T., & Forcada, N. (2022). Thermal comfort of older people during summer in the continental Mediterranean climate. *Journal of Building Engineering* 54: 104680. <https://doi.org/10.1016/j.jobbe.2022.104680>

Barakat, A., Ayad, H., & El-Sayed, Z. (2017). Urban design in favor of human thermal comfort for hot arid climate using advanced simulation methods. *Alexandria Engineering Journal* 56(4): 533-543. <https://doi.org/10.1016/j.aej.2017.04.008>

- Barry, K. M., Woods, M., Warnecke, E., Stirling, C., & Martin, A. (2018). Psychological health of doctoral candidates, study-related challenges and perceived performance. *Higher Education Research & Development* 37(3): 468-483. <https://doi.org/10.1080/07294360.2018.1425979>
- Bartesaghi-Koc, C., Haddad, S., Pignatta, G., Paolini, R., Prasad, D., & Santamouris, M. (2021). Can urban heat be mitigated in a single urban street? Monitoring, strategies, and performance results from a real scale redevelopment project. *Solar Energy* 216: 564-588. <https://doi.org/10.1016/j.solener.2020.12.043>
- Baruti, M. M., Johansson, E., & Åstrand, J. (2019). Review of studies on outdoor thermal comfort in warm humid climates: challenges of informal urban fabric. *International Journal of Biometeorology* 63: 1449-1462. <https://doi.org/10.1007/s00484-019-01757-3>
- Battista, G., Carnielo, E., & Vollaro, R. D. L. (2016). Thermal impact of a redeveloped area on localized urban microclimate: A case study in Rome. *Energy and Buildings* 133: 446-454. <https://doi.org/10.1016/j.enbuild.2016.10.004>
- Battisti, A., Laureti, F., Zinzi, M., & Volpicelli, G. (2018). Climate mitigation and adaptation strategies for roofs and pavements: A case study at Sapienza University Campus. *Sustainability* 10(10): 3788. <https://doi.org/10.3390/su10103788>
- Beck, C., Grieser, J., Kottek, M., Rubel, F., & Rudolf, B. (2005). Characterizing global climate change by means of Köppen climate classification. *Klimastatusbericht* 51: 139-149.
- Beck, H. E., Zimmermann, N. E., McVicar, T. R., Vergopolan, N., Berg, A., & Wood, E. F. (2018). Present and future Köppen-Geiger climate classification maps at 1-km resolution. *Scientific Data* 5(1): 1-12. <https://doi.org/10.1038/sdata.2018.214>
- Belda, M., Holtanová, E., Halenka, T., & Kalvová, J. (2014). Climate classification revisited: from Köppen to Trewartha. *Climate Research* 59(1): 1-13.
- Bennett, J. (2007). Wind design guide. *Architectural aerodynamics course*, Victoria university of Wellington, Course: BBSC_442.
- Berardi, U., Jandaghian, Z., & Graham, J. (2020). Effects of greenery enhancements for the resilience to heat waves: A comparison of analysis performed through mesoscale (WRF) and microscale (Envi-met) modeling. *Science of the Total Environment* 747: 141300. <https://doi.org/10.1016/j.scitotenv.2020.141300>
- Blazejczyk, K., Epstein, Y., Jendritzky, G., Staiger, H., & Tinz, B. (2012). Comparison of UTCI to selected thermal indices. *International Journal of Biometeorology* 56: 515-535. <https://doi.org/10.1007/s00484-011-0453-2>

- Blocken, B. (2015). Computational Fluid Dynamics for urban physics: Importance, scales, possibilities, limitations and ten tips and tricks towards accurate and reliable simulations. *Building and Environment* 91: 219-245. <https://doi.org/10.1016/j.buildenv.2015.02.015>
- Bluyssen, P. M. (2010). Towards new methods and ways to create healthy and comfortable buildings. *Building and Environment* 45(4): 808-818. <https://doi.org/10.1016/j.buildenv.2009.08.020>
- Böcker, L., Dijst, M., & Prillwitz, J. (2013). Impact of everyday weather on individual daily travel behaviours in perspective: a literature review. *Transport Reviews* 33(1): 71-91. <https://doi.org/10.1080/01441647.2012.747114>
- Bolton, A. V., Montag, D., & Gallo, V. (2022). Global forestry areas, deforestation and mental health: a worldwide ecological study. *The Journal of Climate Change and Health* 6: 100109. <https://doi.org/10.1016/j.joelim.2021.100109>
- Boretti, A., & Watson, T. T. (2011). Is New Zealand globally warming? *International Journal of Global Warming* 3(3): 219-231. <https://doi.org/10.1504/IJGW.2011.043420>
- Bozzhigitov, A., Memon, S. A., & Adilkhanova, I. (2022). Sensitivity of energy performance to the selection of PCM melting temperature for the building located in Cfb climate zone. *Energy Reports* 8: 6301-6320. <https://doi.org/10.1016/j.egy.2022.04.059>
- Broekhuizen, N., Plew, D. R., Pinkerton, M. H., & Gall, M. G. (2021). Sea temperature rise over the period 2002–2020 in Pelorus Sound, New Zealand—with possible implications for the aquaculture industry. *New Zealand Journal of Marine and Freshwater Research* 55(1): 46-64. <https://doi.org/10.1080/00288330.2020.1868539>
- Brook-Lawson, J., & Holz, S. (2020). CFD Comparison Project for Wind Simulation in Landscape Architecture. *Journal of Digital Landscape Architecture*: 318-329.
- Brown, R. D., Vanos, J., Kenny, N., & Lenzholzer, S. (2015). Designing urban parks that ameliorate the effects of climate change. *Landscape and Urban Planning* 138: 118-131. <https://doi.org/10.1016/j.landurbplan.2015.02.006>
- Brozovsky, J., Corio, S., Gaitani, N., & Gustavsen, A. (2021). Evaluation of sustainable strategies and design solutions at high-latitude urban settlements to enhance outdoor thermal comfort. *Energy and Buildings* 244: 111037. <https://doi.org/10.1016/j.enbuild.2021.111037>
- Buffel, T., & Phillipson, C. (2016). Can global cities be ‘age-friendly cities’? Urban development and ageing populations. *Cities* 55: 94-100. <https://doi.org/10.1016/j.cities.2016.03.016>

- Cameron, J. K., Hall, L., Tong, S. Y., Paterson, D. L., & Halton, K. (2019). Incidence of community onset MRSA in Australia: least reported where it is Most prevalent. *Antimicrobial Resistance & Infection Control* 8(1): 1-9. <https://doi.org/10.1186/s13756-019-0485-7>
- Cammelli, S., & Stanfield, R. (2017). Meeting the challenges of planning policy for wind microclimate of high-rise developments in London. *Procedia Engineering* 198: 43-51. <https://doi.org/10.1016/j.proeng.2017.07.163>
- Chambers, L., & Griffiths, G. (2008). The changing nature of temperature extremes in Australia and New Zealand. *Australian Meteorological Magazine* 57(1): 13-35.
- Chatterjee, S., Khan, A., Dinda, A., Mithun, S., Khatun, R., Akbari, H., Kusaka, H., Mitra, C., Bhatti, S. S., & Van Doan, Q. (2019). Simulating micro-scale thermal interactions in different building environments for mitigating urban heat islands. *Science of the Total Environment* 663: 610-631. <https://doi.org/10.1016/j.scitotenv.2019.01.299>
- Chatzidimitriou, A., & Yannas, S. (2016). Microclimate design for open spaces: Ranking urban design effects on pedestrian thermal comfort in summer. *Sustainable Cities and Society* 26: 27-47. <https://doi.org/10.1016/j.scs.2016.05.004>
- Chatzidimitriou, A., & Yannas, S. (2017). Street canyon design and improvement potential for urban open spaces; the influence of canyon aspect ratio and orientation on microclimate and outdoor comfort. *Sustainable Cities and Society* 33: 85-101. <https://doi.org/10.1016/j.scs.2017.05.019>
- Chatzinikolaou, E., Chalkias, C., & Dimopoulou, E. (2018). Urban microclimate improvement using envi-met climate model. *International Archives Of The Photogrammetry, Remote Sensing & Spatial Information Sciences* 42(4). <https://doi.org/10.5194/isprs-archives-XLII-4-69-2018>
- Chatzipoulka, C., Compagnon, R., Kaempf, J., & Nikolopoulou, M. (2018). Sky view factor as predictor of solar availability on building façades. *Solar Energy* 170: 1026-1038. <https://doi.org/10.1016/j.solener.2018.06.028>
- Chatzipoulka, C., Steemers, K., & Nikolopoulou, M. (2020). Density and coverage values as indicators of thermal diversity in open spaces: Comparative analysis of London and Paris based on sun and wind shadow maps. *Cities* 100: 102645. <https://doi.org/10.1016/j.cities.2020.102645>
- Chen, C.-H., & Wu, K.-C. (2020, October 23-25). *Innovative remote sensing system measuring microclimate of street canyon*. IEEE Eurasia Conference on IOT, Communication and Engineering (ECICE), IEEE. <https://doi.org/10.1109/ECICE50847.2020.9302022>

- Chen, D., & Chen, H. W. (2013). Using the Köppen classification to quantify climate variation and change: An example for 1901–2010. *Environmental Development* 6: 69-79. <https://doi.org/10.1016/j.envdev.2013.03.007>
- Chen, L., Kántor, N., & Nikolopoulou, M. (2022). Meta-analysis of outdoor thermal comfort surveys in different European cities using the RUROS database: The role of background climate and gender. *Energy and Buildings* 256: 111757. <https://doi.org/10.1016/j.enbuild.2021.111757>
- Chen, L., & E. Ng (2012). Outdoor thermal comfort and outdoor activities: A review of research in the past decade. *Cities* 29(2): 118-125. <https://doi.org/10.1016/j.cities.2011.08.006>
- Chen, L., Zhang, Y., Han, J., & Li, X. (2021). An investigation of the influence of ground surface properties and shading on outdoor thermal comfort in a high-altitude residential area. *Frontiers of Architectural Research* 10(2): 432-446. <https://doi.org/10.1016/j.foar.2020.12.005>
- Chen, T., Yang, H., Chen, G., Lam, C. K. C., Hang, J., Wang, X., Liu, Y., & Ling, H. (2021). Integrated impacts of tree planting and aspect ratios on thermal environment in street canyons by scaled outdoor experiments. *Science of The Total Environment* 764: 142920. <https://doi.org/10.1016/j.scitotenv.2020.142920>
- Chen, Y.-C., & Matzarakis, A. (2018). Modified physiologically equivalent temperature—Basics and applications for western European climate. *Theoretical and Applied Climatology* 132: 1275-1289. <https://doi.org/10.1007/s00704-017-2158-x>
- Cheng, V., Ng, E., Chan, C., & Givoni, B. (2012). Outdoor thermal comfort study in a subtropical climate: a longitudinal study based in Hong Kong. *International Journal of Biometeorology* 56: 43-56. <https://doi.org/10.1007/s00484-010-0396-z>
- Cheung, C. S. C., & Hart, M. A. (2014). Climate change and thermal comfort in Hong Kong. *International Journal of Biometeorology* 58: 137-148. <https://doi.org/10.1007/s00484-012-0608-9>
- Cheung, P. K., & Jim, C. Y. (2018). Comparing the cooling effects of a tree and a concrete shelter using PET and UTCI. *Building and Environment* 130: 49-61. <https://doi.org/10.1016/j.buildenv.2017.12.013>
- Cheung, P. K., & Jim, C. Y. (2019). Improved assessment of outdoor thermal comfort: 1-hour acceptable temperature range. *Building and Environment* 151: 303-317. <https://doi.org/10.1016/j.buildenv.2019.01.057>
- Cheung, P. K., Jim, C. Y., Tapper, N., Nice, K. A., & Livesley, S. J. (2022). Daytime irrigation leads to significantly cooler private backyards in summer. *Urban Climate* 46: 101310. <https://doi.org/10.1016/j.uclim.2022.101310>

- Chew, L. W., Nazarian, N., & Norford, L. (2017). Pedestrian-level urban wind flow enhancement with wind catchers. *Atmosphere* 8(9): 159. <https://doi.org/10.3390/atmos8090159>
- Chew, L. W., & Norford, L. K. (2018). Pedestrian-level wind speed enhancement in urban street canyons with void decks. *Building and Environment* 146: 64-76. <https://doi.org/10.1016/j.buildenv.2018.09.039>
- Chilibeck, C. M., Brookes, N. H., Gokul, A., Kim, B. Z., Twohill, H. C., Moffatt, S. L., Pendergrast, D. G., & McGhee, C. N. (2022). Changing trends in corneal transplantation in Aotearoa/New Zealand, 1991 to 2020: effects of population growth, cataract surgery, endothelial keratoplasty, and corneal cross-linking for keratoconus. *Cornea* 41(6): 680-687.
- Chmielewski, F. M., Blüme, K., Henniges, I., Y., Blanke, M., Weber, R. W., & Zoth, M. (2011). Phenological models for the beginning of apple blossom in Germany. *Meteorologische Zeitschrift* 20(5): 487.
- Cilek, M. U., & Cilek, A. (2021). Analyses of land surface temperature (LST) variability among local climate zones (LCZs) comparing Landsat-8 and ENVI-met model data. *Sustainable Cities and Society* 69: 102877. <https://doi.org/10.1016/j.scs.2021.102877>
- Colunga, M. L., Cambrón-Sandoval, V. H., Suzán-Azpiri, H., Guevara-Escobar, A., & Luna-Soria, H. (2015). The role of urban vegetation in temperature and heat island effects in Querétaro city, Mexico. *Atmósfera* 28(3): 205-218. <https://doi.org/10.20937/ATM.2015.28.03.05>
- Cortese, J. P. A. G. (2013). *Thermal retrofitting of public spaces in compact urban areas: A bioclimatic approach*, Universidade do Porto (Portugal).
- Coutts, A. M., White, E. C., Tapper, N. J., Beringer, J., & Livesley, S. J. (2016). Temperature and human thermal comfort effects of street trees across three contrasting street canyon environments. *Theoretical and Applied Climatology* 124: 55-68. <https://doi.org/10.1007/s00704-015-1409-y>
- Crank, P. J., Middel, A., Wagner, M., Hoots, D., Smith, M., & Brazel, A. (2020). Validation of seasonal mean radiant temperature simulations in hot arid urban climates. *Science of the Total Environment* 749: 141392. <https://doi.org/10.1016/j.scitotenv.2020.141392>
- Crosbie, R., Pollock, D., Mpelasoka, F., Barron, O., Charles, S., & Donn, M. (2012). Changes in Köppen-Geiger climate types under a future climate for Australia: hydrological implications. *Hydrology and Earth System Sciences* 16(9): 3341-3349. <https://doi.org/10.5194/hess-16-3341-2012>

- Cui, D., Zhang, Y., Li, X., Yuan, L., Mak, C. M., & Kwok, K. (2022). Effects of different vertical façade greenery systems on pedestrian thermal comfort in deep street canyons. *Urban Forestry & Urban Greening* 72: 127582. <https://doi.org/10.1016/j.ufug.2022.127582>
- Currie, J. S., & Clarke, B. (2022). Fighting talk: The use of the conceptual metaphor climate change is conflict in the UK Houses of Parliament, 2015–2019. *Journal of Language and Politics*. <https://doi.org/10.1075/jlp.21052.cur>
- Cybriwsky, R. (1999). Changing patterns of urban public space: observations and assessments from the Tokyo and New York metropolitan areas. *Cities* 16(4): 223-231. [https://doi.org/10.1016/S0264-2751\(99\)00021-9](https://doi.org/10.1016/S0264-2751(99)00021-9)
- Dardir, M., & Berardi, U. (2021). Development of microclimate modeling for enhancing neighborhood thermal performance through urban greenery cover. *Energy and Buildings* 252: 111428. <https://doi.org/10.1016/j.enbuild.2021.111428>
- Das, M., Das, A., & Mandal, S. (2020). Outdoor thermal comfort in different settings of a tropical planning region: a study on Sriniketan-Santiniketan Planning Area (SSPA), Eastern India. *Sustainable Cities and Society* 63: 102433. <https://doi.org/10.1016/j.scs.2020.102433>
- Davidson, K., Briggs, J., Nolan, E., Bush, J., Håkansson, I., & Moloney, S. (2020). The making of a climate emergency response: Examining the attributes of climate emergency plans. *Urban Climate* 33: 100666. <https://doi.org/10.1016/j.uclim.2020.100666>
- De, B., & Mukherjee, M. (2018). Optimisation of canyon orientation and aspect ratio in warm-humid climate: Case of Rajarhat Newtown, India. *Urban Climate* 24: 887-920. <https://doi.org/10.1016/j.uclim.2017.11.003>
- De Dear, R. J., & Brager, G. S. (2002). Thermal comfort in naturally ventilated buildings: revisions to ASHRAE Standard 55. *Energy and Buildings* 34(6): 549-561. [https://doi.org/10.1016/S0378-7788\(02\)00005-1](https://doi.org/10.1016/S0378-7788(02)00005-1)
- De Freitas, C., Dawson, N., Young, A., & Mackey, W. (1985). Microclimate and heat stress of runners in mass participation events. *Journal of Applied Meteorology and Climatology* 24(2): 184-191. [https://doi.org/10.1175/1520-0450\(1985\)024%3C0184:MAHSOR%3E2.0.CO;2](https://doi.org/10.1175/1520-0450(1985)024%3C0184:MAHSOR%3E2.0.CO;2)
- De Luca, F., Naboni, E., & Lobaccaro, G. (2021). Tall buildings cluster form rationalization in a Nordic climate by factoring in indoor-outdoor comfort and energy. *Energy and Buildings* 238: 110831. <https://doi.org/10.1016/j.enbuild.2021.110831>
- De Vet, E. (2017). Experiencing and responding to everyday weather in Darwin, Australia: The important role of tolerance. *Weather, Climate, and Society* 9(2): 141-154. <https://doi.org/10.1175/WCAS-D-15-0069.1>

- Deevi, B., & Chundeli, F. A. (2020). Quantitative outdoor thermal comfort assessment of street: A case in a warm and humid climate of India. *Urban Climate* 34: 100718. <https://doi.org/10.1016/j.uclim.2020.100718>
- Deng, J.-Y., & Wong, N. H. (2020). Impact of urban canyon geometries on outdoor thermal comfort in central business districts. *Sustainable Cities and Society* 53: 101966. <https://doi.org/10.1016/j.scs.2019.101966>
- Deng, J.-Y., Wong, N. H., & Zheng, X. (2016). The study of the effects of building arrangement on microclimate and energy demand of CBD in Nanjing, China. *Procedia Engineering* 169: 44-54. <https://doi.org/10.1016/j.proeng.2016.10.006>
- Deng, J., Pickles, B. J., Kavakopoulos, A., Blanusa, T., Halios, C. H., Smith, S. T., & Shao, L. (2019). Concept and methodology of characterising infrared radiative performance of urban trees using tree crown spectroscopy. *Building and Environment* 157: 380-390. <https://doi.org/10.1016/j.buildenv.2019.04.056>
- Denis, E., & Marius-Gnanou, K. (2010). Toward a better appraisal of urbanization in India. A fresh look at the landscape of morphological agglomerates. *Cybergeo: European Journal of Geography*. <https://doi.org/10.4000/cybergeo.24798>
- Dimitrova, B., Vuckovic, M., Kiesel, K., & Mahdavi, A. (2014, May 1-8). *Trees and the microclimate of the urban canyon: A case study*. ICAUD, 2nd International Conference on Architecture and Urban Design, Epoka University, Tirana, Albania. <http://dspace.epoka.edu.al/handle/1/953>
- Douglas, O., Lennon, M., & Scott, M. (2017). Green space benefits for health and well-being: A life-course approach for urban planning, design and management. *Cities* 66: 53-62. <https://doi.org/10.1016/j.cities.2017.03.011>
- Doulos, L., Santamouris, M., & Livada, I. (2004). Passive cooling of outdoor urban spaces. The role of materials. *Solar Energy* 77(2): 231-249. <https://doi.org/10.1016/j.solener.2004.04.005>
- Dounis, A. I., & Caraiscos, C. (2009). Advanced control systems engineering for energy and comfort management in a building environment—A review. *Renewable and Sustainable Energy Reviews* 13(6-7): 1246-1261. <https://doi.org/10.1016/j.rser.2008.09.015>
- Du, Y., & Mak, C. M. (2018). Improving pedestrian level low wind velocity environment in high-density cities: A general framework and case study. *Sustainable Cities and Society* 42: 314-324. <https://doi.org/10.1016/j.scs.2018.08.001>

- Du, Y., Mak, C. M., Huang, T., & Niu, J. (2017). Towards an integrated method to assess effects of lift-up design on outdoor thermal comfort in Hong Kong. *Building and Environment* 125: 261-272. <https://doi.org/10.1016/j.buildenv.2017.09.001>
- Duarte, D. H., Shinzato, P., dos Santos Gusson, C., & Alves, C. A. (2015). The impact of vegetation on urban microclimate to counterbalance built density in a subtropical changing climate. *Urban Climate* 14: 224-239. <https://doi.org/10.1016/j.uclim.2015.09.006>
- Dzyuban, Y., Ching, G. N., Yik, S. K., Tan, A. J., Banerjee, S., Crank, P. J., & Chow, W. T. (2022). Outdoor thermal comfort research in transient conditions: A narrative literature review. *Landscape and Urban Planning* 226: 104496. <https://doi.org/10.1016/j.landurbplan.2022.104496>
- Eames, C. (2017). Climate change education in New Zealand. *Curriculum Perspectives* 37(1): 99-102. <https://doi.org/10.1007/s41297-017-0017-7>
- East, M., Hajdukova, E. B., Carr, M. E., Evans, W. H., & Hornby, G. (2017). Comparative review of education doctorates in three countries. *The Future of Accessibility in International Higher Education*: 175-201.
- El Bat, A. M. S., Romani, Z., Bozonnet, E., & Draoui, A. (2021). Thermal impact of street canyon microclimate on building energy needs using TRNSYS: A case study of the city of Tangier in Morocco. *Case Studies in Thermal Engineering* 24: 100834. <https://doi.org/10.1016/j.csite.2020.100834>
- Eliasson, I., Knez, I., Westerberg, U., Thorsson, S., & Lindberg, F. (2007). Climate and behaviour in a Nordic city. *Landscape and Urban Planning* 82(1-2): 72-84. <https://doi.org/10.1016/j.landurbplan.2007.01.020>
- Elnabawi, M. H., & Hamza, N. (2019). Behavioural perspectives of outdoor thermal comfort in urban areas: a critical review. *Atmosphere* 11(1): 51. <https://doi.org/10.3390/atmos11010051>
- Elnabawi, M. H., & Hamza, N. (2020). Outdoor thermal comfort: Coupling microclimatic parameters with subjective thermal assessment to design urban performative spaces. *Buildings* 10(12): 238. <https://doi.org/10.3390/buildings10120238>
- Emmanuel, R., & Fernando, H. J. (2007). Urban heat islands in humid and arid climates: role of urban form and thermal properties in Colombo, Sri Lanka and Phoenix, USA. *Climate Research* 34(3): 241-251. <https://doi.org/10.3354/cr00694>
- Emmanuel, R., & Johansson, E. (2006). Influence of urban morphology and sea breeze on hot humid microclimate: the case of Colombo, Sri Lanka. *Climate Research* 30(3): 189-200. <https://doi.org/10.3354/cr030189>

- Emmanuel, R., & Krüger, E. (2012). Urban heat island and its impact on climate change resilience in a shrinking city: The case of Glasgow, UK. *Building and Environment* 53: 137-149. <https://doi.org/10.1016/j.buildenv.2012.01.020>
- Emmanuel, R., & Steemers, K. (2018). Connecting the realms of urban form, density and microclimate. *Taylor & Francis*. 46: 804-808. <https://doi.org/10.1080/09613218.2018.1507078>
- Epstein, Y., & Moran, D. S. (2006). Thermal comfort and the heat stress indices. *Industrial Health* 44(3): 388-398. <https://doi.org/10.2486/indhealth.44.388>
- Erlwein, S., & Pauleit, S. (2021). Trade-offs between urban green space and densification: Balancing outdoor thermal comfort, mobility, and housing demand. *Urban Planning* 6(1): 5-19. <https://doi.org/10.17645/up.v6i1.3481>
- Eusuf, M. A., Mohit, M. A., Eusuf, M. S., & Ibrahim, M. (2014). Impact of outdoor environment to the quality of life. *Procedia-Social and Behavioral Sciences* 153: 639-654. <https://doi.org/10.1016/j.sbspro.2014.10.096>
- Evola, G., Costanzo, V., Magrì, C., Margani, G., Marletta, L., & Naboni, E. (2020). A novel comprehensive workflow for modelling outdoor thermal comfort and energy demand in urban canyons: Results and critical issues. *Energy and Buildings* 216: 109946. <https://doi.org/10.1016/j.enbuild.2020.109946>
- Evola, G., Magrì, C., Margani, G., & Naboni, E. (2019, September 2-4). *Modelling Outdoor Thermal Comfort and Energy Demand in Urban Canyons: Validation of a Novel Comprehensive Parametric Workflow*. Building Simulation Conference Proceedings, 16th IBPSA International Conference, Rome, Italy.
- Fabbri, K., Ugolini, A., Iacovella, A. & Bianchi, A. P. (2020). The effect of vegetation in outdoor thermal comfort in archaeological area in urban context. *Building and Environment* 175: 106816. <https://doi.org/10.1016/j.buildenv.2020.106816>
- Fahmi, F. Z., Hudalah, D., Rahayu, P., & Woltjer, J. (2014). Extended urbanization in small and medium-sized cities: The case of Cirebon, Indonesia. *Habitat International* 42: 1-10. <https://doi.org/10.1016/j.habitatint.2013.10.003>
- Falasca, S., Zinzi, M., Ding, L., Curci, G., & Santamouris, M. (2022). On the mitigation potential of higher urban albedo in a temperate oceanic metropolis. *Sustainable Cities and Society* 81: 103850. <https://doi.org/10.1016/j.scs.2022.103850>
- Fang, C., Cui, X., Li, G., Bao, C., Wang, Z., Ma, H., Sun, S., Liu, H., Luo, K., & Ren, Y. (2019). Modeling regional sustainable development scenarios using the Urbanization and Eco-environment Coupler: Case study of Beijing-Tianjin-Hebei urban agglomeration, China.

- Science of the Total Environment* 689: 820-830.
<https://doi.org/10.1016/j.scitotenv.2019.06.430>
- Fang, Z., Feng, X., & Lin, Z. (2017). Investigation of PMV model for evaluation of the outdoor thermal comfort. *Procedia Engineering* 205: 2457-2462.
<https://doi.org/10.1016/j.proeng.2017.09.973>
- Fang, Z., Feng, X., Liu, J., Lin, Z., Mak, C. M., Niu, J., Tse, K.-T., & Xu, X. (2019). Investigation into the differences among several outdoor thermal comfort indices against field survey in subtropics. *Sustainable Cities and Society* 44: 676-690.
<https://doi.org/10.1016/j.scs.2018.10.022>
- Fang, Z., Zheng, Z., Feng, X., Shi, D., Lin, Z., & Gao, Y. (2021). Investigation of outdoor thermal comfort prediction models in South China: A case study in Guangzhou. *Building and Environment* 188: 107424. <https://doi.org/10.1016/j.buildenv.2020.107424>
- Fawzy Abdulsalam, O., & Haleem Hussien, A. (2021). Implications of urban space aspect ratio on campus outdoor thermal comfort (Case study, BUE campus, Cairo, Egypt). *Engineering Research Journal* 170: 1-10.
- Feyisa, G. L., Dons, K., & Meilby, H. (2014). Efficiency of parks in mitigating urban heat island effect: An example from Addis Ababa. *Landscape and Urban Planning* 123: 87-95.
<https://doi.org/10.1016/j.landurbplan.2013.12.008>
- Flay, R., & Andrews, R. (1995). A wind tunnel/full-scale comparison of the wind flow over Auckland City." *Journal of Wind Engineering and Industrial Aerodynamics* 54: 151-161.
[https://doi.org/10.1016/0167-6105\(94\)00038-F](https://doi.org/10.1016/0167-6105(94)00038-F)
- Fleck, R., Gill, R., Saadeh, S., Pettit, T., Wooster, E., Torpy, F., & Irga, P. (2022). Urban green roofs to manage rooftop microclimates: A case study from Sydney, Australia. *Building and Environment* 209: 108673. <https://doi.org/10.1016/j.buildenv.2021.108673>
- Fleckenstein, J., Molter, P., Chokhachian, A., & Dörfler, K. (2022). Climate-Resilient Robotic Facades: Architectural Strategies to Improve Thermal Comfort in Outdoor Urban Environments using Robotic Assembly. *Built Environment* 8: 856871.
- Fong, C. S., Aghamohammadi, N., Ramakreshnan, L., Sulaiman, N. M., & Mohammadi, P. (2019). Holistic recommendations for future outdoor thermal comfort assessment in tropical Southeast Asia: A critical appraisal. *Sustainable Cities and Society* 46: 101428.
<https://doi.org/10.1016/j.scs.2019.101428>
- Forouzandeh, A. (2021). Prediction of surface temperature of building surrounding envelopes using holistic microclimate ENVI-met model. *Sustainable Cities and Society* 70: 102878.
<https://doi.org/10.1016/j.scs.2021.102878>

- Founda, D., & Santamouris, M. (2017). Synergies between Urban Heat Island and Heat Waves in Athens (Greece), during an extremely hot summer (2012). *Scientific Reports* 7(1): 1-11. <https://doi.org/10.1038/s41598-017-11407-6>
- Gago, E. J., Roldan, J., Pacheco-Torres, R., & Ordóñez, J. (2013). The city and urban heat islands: A review of strategies to mitigate adverse effects. *Renewable and Sustainable Energy Reviews* 25: 749-758. <https://doi.org/10.1016/j.rser.2013.05.057>
- Gaitani, N., Santamouris, M., Cartalis, C., Pappas, I., Xyrafi, F., Mastrapostoli, E., Karahaliou, P., & Efthymiou, C. (2014). Microclimatic analysis as a prerequisite for sustainable urbanisation: Application for an urban regeneration project for a medium size city in the greater urban agglomeration of Athens, Greece. *Sustainable Cities and Society* 13: 230-236. <https://doi.org/10.1016/j.scs.2014.02.006>
- Gál, C. V. (2014, February 4-6). *The impact of built form on the urban microclimate at the scale of city blocks*. 94th Annual Meeting of the American Meteorological Society (AMS) jointly with the 11th Symposium on the Urban Environment, Atlanta, GA.
- Gál, C. V. (2014). The influence of built form and vegetation on the canopy layer microclimate within urban blocks. *Acta Climatol. Chorologica* 47(48): 43-52.
- Gál, C. V., & Kántor, N. (2020). Modeling mean radiant temperature in outdoor spaces, A comparative numerical simulation and validation study. *Urban Climate* 32: 100571. <https://doi.org/10.1016/j.uclim.2019.100571>
- Galal, O. M., Sailor, D. J., & Mahmoud, H. (2020). The impact of urban form on outdoor thermal comfort in hot arid environments during daylight hours, case study: New Aswan. *Building and Environment* 184: 107222. <https://doi.org/10.1016/j.buildenv.2020.107222>
- Galindo, T., & Hermida, M. A. (2018). Effects of thermophysiological and non-thermal factors on outdoor thermal perceptions: The Tomebamba Riverbanks case. *Building and Environment* 138: 235-249. <https://doi.org/10.1016/j.buildenv.2018.04.024>
- Garcia-Nevado, E., & Coch, H. (2016). Solar access assessment in dense urban environments: The effect of intersections in an urban canyon. *Energies* 9(10): 796. <https://doi.org/10.3390/en9100796>
- Garuma, G. F. (2018). Review of urban surface parameterizations for numerical climate models. *Urban Climate* 24: 830-851. <https://doi.org/10.1016/j.uclim.2017.10.006>
- Gasparri, A., Guo, Y., Sera, F., Vicedo-Cabrera, A. M., Huber, V., Tong, S., Coelho, M. d. S. Z. S., Saldiva, P. H. N., Lavigne, E., & Correa, P. M. (2017). Projections of temperature-related excess mortality under climate change scenarios. *The Lancet Planetary Health* 1(9): e360-e367. [https://doi.org/10.1016/S2542-5196\(17\)30156-0](https://doi.org/10.1016/S2542-5196(17)30156-0)

- Gatto, E., Buccolieri, R., Aarrevaara, E., Ippolito, F., Emmanuel, R., Perronace, L., & Santiago, J. L. (2020). Impact of Urban Vegetation on Outdoor Thermal Comfort: Comparison between a Mediterranean City (Lecce, Italy) and a Northern European City (Lahti, Finland). *Forests* 11(2): 228. <https://doi.org/10.3390/f11020228>
- Ghaffarianhoseini, A., Berardi, U., & Ghaffarianhoseini, A. (2015). Thermal performance characteristics of unshaded courtyards in hot and humid climates. *Building and Environment* 87: 154-168. <https://doi.org/10.1016/j.buildenv.2015.02.001>
- Ghaffarianhoseini, A., Berardi, U., Ghaffarianhoseini, A., & Al-Obaidi, K. (2019). Analyzing the thermal comfort conditions of outdoor spaces in a university campus in Kuala Lumpur, Malaysia. *Science of the Total Environment* 666: 1327-1345. <https://doi.org/10.1016/j.scitotenv.2019.01.284>
- Gilani, S., Montazeri, H., & Blocken, B. (2016). CFD simulation of stratified indoor environment in displacement ventilation: Validation and sensitivity analysis. *Building and Environment* 95: 299-313. <https://doi.org/10.1016/j.buildenv.2015.09.010>
- Givoni, B. (1991). Impact of planted areas on urban environmental quality: a review. *Atmospheric Environment. Part B. Urban Atmosphere* 25(3): 289-299. [https://doi.org/10.1016/0957-1272\(91\)90001-U](https://doi.org/10.1016/0957-1272(91)90001-U)
- Glover, A., Strengers, Y., & Lewis, T. (2017). The unsustainability of academic aeromobility in Australian universities. *Sustainability: Science, Practice and Policy* 13(1): 1-12. <https://doi.org/10.1080/15487733.2017.1388620>
- Golasi, I., Salata, F., Lieto Vollaro, E. de, & Coppi, M. (2018). Complying with the demand of standardization in outdoor thermal comfort: a first approach to the Global Outdoor Comfort Index (GOCI). *Building and Environment* 130: 104-119. <https://doi.org/10.1016/j.buildenv.2017.12.021>
- Golden, J. S. (2004). The built environment induced urban heat island effect in rapidly urbanizing arid regions—a sustainable urban engineering complexity. *Environmental Sciences* 1(4): 321-349. <https://doi.org/10.1080/15693430412331291698>
- Golding, C., Sharmini, S., & Lazarovitch, A. (2014). What examiners do: What thesis students should know. *Assessment & Evaluation in Higher Education* 39(5): 563-576. <https://doi.org/10.1080/02602938.2013.859230>
- Gong, F.-Y., Zeng, Z.-C., Ng, E., & Norford, L. K. (2019). Spatiotemporal patterns of street-level solar radiation estimated using Google Street View in a high-density urban environment. *Building and Environment* 148: 547-566. <https://doi.org/10.1016/j.buildenv.2018.10.025>

- Gong, F.-Y., Zeng, Z.-C., Zhang, F., Li, X., Ng, E., & Norford, L. K. (2018). Mapping sky, tree, and building view factors of street canyons in a high-density urban environment. *Building and Environment* 134: 155-167. <https://doi.org/10.1016/j.buildenv.2018.02.042>
- González, C. M. M., Rodríguez, A. L., Medina, R. S., & Jaramillo, J. R. (2020). Effects of future climate change on the preservation of artworks, thermal comfort and energy consumption in historic buildings. *Applied Energy* 276: 115483. <https://doi.org/10.1016/j.apenergy.2020.115483>
- Graw, K., Sommer, M., & Matzarakis, A. (2022). The Prevalence of Weather Sensitivity in Germany Derived from Population Surveys. *Atmosphere* 13(11): 1865. <https://doi.org/10.3390/atmos13111865>
- Gromke, C., & Ruck, B. (2012). Pollutant concentrations in street canyons of different aspect ratio with avenues of trees for various wind directions. *Boundary-Layer Meteorology* 144(1): 41-64. <https://doi.org/10.1007/s10546-012-9703-z>
- Gros, A., Bozonnet, E., Inard, C., & Musy, M. (2016). Simulation tools to assess microclimate and building energy—A case study on the design of a new district. *Energy and Buildings* 114: 112-122. <https://doi.org/10.1016/j.enbuild.2015.06.032>
- Gulyás, Á., Unger, J., & Matzarakis, A. (2006). Assessment of the microclimatic and human comfort conditions in a complex urban environment: modelling and measurements. *Building and Environment* 41(12): 1713-1722. <https://doi.org/10.1016/j.buildenv.2005.07.001>
- Gunawardena, K., Kershaw, T., & Steemers, K. (2019). Simulation pathway for estimating heat island influence on urban/suburban building space-conditioning loads and response to facade material changes. *Building and Environment* 150: 195-205. <https://doi.org/10.1016/j.buildenv.2019.01.006>
- Habibi, K., Hoseini, S. M., Dehshti, M., Khanian, M., & Mosavi, A. (2020). The impact of natural elements on environmental comfort in the Iranian-Islamic historical city of Isfahan. *International Journal of Environmental Research and Public Health* 17(16): 5776. <https://doi.org/10.3390/ijerph17165776>
- Hadavi, M., & Pasdarsahri, H. (2021). Impacts of urban buildings on microclimate and cooling systems efficiency: Coupled CFD and BES simulations. *Sustainable Cities and Society* 67: 102740. <https://doi.org/10.1016/j.scs.2021.102740>
- Han, X., Zhang, J., Rao, Y., & Jing, G. (2019). Hindering the impact of building characteristics on greenbelt cooling effects: A perspective of quantitative simulation with in situ measurements. *Science of the Total Environment* 670: 308-319. <https://doi.org/10.1016/j.scitotenv.2019.03.229>

- Harmay, N. S. M., Kim, D., & Choi, M. (2021). Urban heat island associated with land use/land cover and climate variations in Melbourne, Australia. *Sustainable Cities and Society* 69: 102861. <https://doi.org/10.1016/j.scs.2021.102861>
- Hastie, T. J., & Pregibon, D. (2017). *Generalized linear models*. Statistical models in S, Routledge.
- Havenith, G., Holmér, I., & Parsons, K. (2002). Personal factors in thermal comfort assessment: clothing properties and metabolic heat production. *Energy and Buildings* 34(6): 581-591. [https://doi.org/10.1016/S0378-7788\(02\)00008-7](https://doi.org/10.1016/S0378-7788(02)00008-7)
- He, B.-J., Ding, L., & Prasad, D. (2020). Wind-sensitive urban planning and design: Precinct ventilation performance and its potential for local warming mitigation in an open midrise gridiron precinct. *Journal of Building Engineering* 29: 101145. <https://doi.org/10.1016/j.jobbe.2019.101145>
- He, J., Liu, J., Zhuang, D., Zhang, W., & Liu, M. (2007). Assessing the effect of land use/land cover change on the change of urban heat island intensity. *Theoretical and Applied Climatology* 90(3): 217-226. <https://doi.org/10.1007/s00704-006-0273-1>
- Heaviside, C., Macintyre, H., & Vardoulakis, S. (2017). The urban heat island: implications for health in a changing environment. *Current Environmental Health Reports* 4(3): 296-305. <https://doi.org/10.1007/s40572-017-0150-3>
- Hegazy, I. R., & Qurnfulah, E. M. (2020). Thermal comfort of urban spaces using simulation tools exploring street orientation influence of on the outdoor thermal comfort: a case study of Jeddah, Saudi Arabia. *International Journal of Low-Carbon Technologies* 15(4): 594-606. <https://doi.org/10.1093/ijlct/ctaa028>
- Heinzl, H., & Mittlböck, M. (2003). Pseudo R-squared measures for Poisson regression models with over-or underdispersion. *Computational Statistics & Data Analysis* 44(1-2): 253-271. [https://doi.org/10.1016/S0167-9473\(03\)00062-8](https://doi.org/10.1016/S0167-9473(03)00062-8)
- Heris, M. P., Middel, A., & Muller, B. (2020). Impacts of form and design policies on urban microclimate: Assessment of zoning and design guideline choices in urban redevelopment projects. *Landscape and Urban Planning* 202: 103870. <https://doi.org/10.1016/j.landurbplan.2020.103870>
- Herrmann, J., & Matzarakis, A. (2012). Mean radiant temperature in idealised urban canyons—examples from Freiburg, Germany. *International Journal of Biometeorology* 56(1): 199-203. <https://doi.org/10.1007/s00484-010-0394-1>

- Hertel, D., & Schlink, U. (2019). Decomposition of urban temperatures for targeted climate change adaptation. *Environmental Modelling & Software* 113: 20-28. <https://doi.org/10.1016/j.envsoft.2018.11.015>
- Heshmat Mohajer, H. R., Ding, L., & Santamouris, M. (2022). Developing Heat Mitigation Strategies in the Urban Environment of Sydney, Australia. *Buildings* 12(7): 903. <https://doi.org/10.3390/buildings12070903>
- Hong, B., & Lin, B. (2015). Numerical studies of the outdoor wind environment and thermal comfort at pedestrian level in housing blocks with different building layout patterns and trees arrangement. *Renewable Energy* 73: 18-27. <https://doi.org/10.1016/j.renene.2014.05.060>
- Hong, T., Xu, Y., Sun, K., Zhang, W., Luo, X., & Hooper, B. (2021). Urban microclimate and its impact on building performance: A case study of San Francisco. *Urban Climate* 38: 100871. <https://doi.org/10.1016/j.uclim.2021.100871>
- Hook, D. W., Porter, S. J., & Herzog, C. (2018). Dimensions: building context for search and evaluation. *Frontiers in Research Metrics and Analytics* 3: 23. <https://doi.org/10.3389/frma.2018.00023>
- Hopkins, D., Campbell-Hunt, C., Carter, L., Higham, J. E., & Rosin, C. (2015). Climate change and Aotearoa New Zealand. Wiley Interdisciplinary Reviews: *Climate Change* 6(6): 559-583. <https://doi.org/10.1002/wcc.355>
- Höppe, P. (1999). The physiological equivalent temperature—a universal index for the biometeorological assessment of the thermal environment. *International Journal of Biometeorology* 43: 71-75. <https://doi.org/10.1007/s004840050118>
- Höppe, P. (2002). Different aspects of assessing indoor and outdoor thermal comfort. *Energy and Buildings* 34(6): 661-665. [https://doi.org/10.1016/S0378-7788\(02\)00017-8](https://doi.org/10.1016/S0378-7788(02)00017-8)
- HosseiniHaghighi, S., Izadi, F., Padsala, R., & Eicker, U. (2020). Using Climate-Sensitive 3D City Modeling to Analyze Outdoor Thermal Comfort in Urban Areas. *ISPRS International Journal of Geo-Information* 9(11): 688. <https://doi.org/10.3390/ijgi9110688>
- Hosseinzadeh, A., & Keshmiri, A. (2021). Computational simulation of wind microclimate in complex urban models and mitigation using trees. *Buildings* 11(3): 112. <https://doi.org/10.3390/buildings11030112>
- Hu, Y., & Jia, G. (2010). Influence of land use change on urban heat island derived from multi-sensor data. *International Journal of Climatology* 30(9): 1382-1395. <https://doi.org/10.1002/joc.1984>

- Hua, J., Zhang, X., Ren, C., Shi, Y., & Lee, T.-C. (2021). Spatiotemporal assessment of extreme heat risk for high-density cities: A case study of Hong Kong from 2006 to 2016. *Sustainable Cities and Society* 64: 102507. <https://doi.org/10.1016/j.scs.2020.102507>
- Huang, K.-T., Lin, T.-P., & Lien, H.-C. (2015). Investigating thermal comfort and user behaviors in outdoor spaces: A seasonal and spatial perspective. *Advances in Meteorology*. <https://doi.org/10.1155/2015/423508>
- Huang, K.-T., Yang, S.-R., Matzarakis, A., & Lin, T.-P. (2018). Identifying outdoor thermal risk areas and evaluation of future thermal comfort concerning shading orientation in a traditional settlement. *Science of the Total Environment* 626: 567-580. <https://doi.org/10.1016/j.scitotenv.2018.01.031>
- Huang, K., Li, X., Liu, X., & Seto, K. C. (2019). Projecting global urban land expansion and heat island intensification through 2050. *Environmental Research Letters* 14(11): 114037. <https://doi.org/10.1088/1748-9326/ab4b71>
- Huang, T.-L., Kuo, C.-Y., Tzeng, C.-T., & Lai, C.-M. (2020). The influence of high-rise buildings on pedestrian-level wind in surrounding street canyons in an urban renewal project. *Energies* 13(11): 2745. <https://doi.org/10.3390/en13112745>
- Huang, T., Li, J., Xie, Y., Niu, J., & Mak, C. M. (2017). Simultaneous environmental parameter monitoring and human subject survey regarding outdoor thermal comfort and its modelling. *Building and Environment* 125: 502-514. <https://doi.org/10.1016/j.buildenv.2017.09.015>
- Huang, T., Niu, J., Mak, C. M., & Lin, Z. (2017). Comparisons of Respondent Thermal Perceptions in Underneath-elevated-building (UEB) Areas and Direct-radiated (DR) Areas, *Procedia Engineering* 205:4156-4171. <https://doi.org/10.1016/j.proeng.2017.10.163>
- Huang, Y., Lei, C., Liu, C.-H., Perez, P., Forehead, H., Kong, S., & Zhou, J. L. (2021). A review of strategies for mitigating roadside air pollution in urban street canyons. *Environmental Pollution* 280: 116971. <https://doi.org/10.1016/j.envpol.2021.116971>
- Hwang, R.-L., Shih, W.-M., Lin, T.-P., & Huang, K.-T. (2018). Simplification and adjustment of the energy consumption indices of office building envelopes in response to climate change. *Applied Energy* 230: 460-470. <https://doi.org/10.1016/j.apenergy.2018.08.090>
- Ignatius, M., Wong, N. H., & Jusuf, S. K. (2015). Urban microclimate analysis with consideration of local ambient temperature, external heat gain, urban ventilation, and outdoor thermal comfort in the tropics. *Sustainable Cities and Society* 19: 121-135. <https://doi.org/10.1016/j.scs.2015.07.016>

- Isaacs, N., & Donn, M. R. (2021). The Inclusion of Microclimate Modelling for House Heating Energy Simulation in Wellington, New Zealand. *Preprint (Version 1) available at Research Square*. <https://doi.org/10.21203/rs.3.rs-673960/v1>
- Ishugah, T., Li, Y., Wang, R., & Kiplagat, J. (2014). Advances in wind energy resource exploitation in urban environment: A review. *Renewable and Sustainable Energy Reviews* 37: 613-626. <https://doi.org/10.1016/j.rser.2014.05.053>
- Israel, B. A., Checkoway, B., Schulz, A., & Zimmerman, M. (1994). Health education and community empowerment: conceptualizing and measuring perceptions of individual, organizational, and community control. *Health Education Quarterly* 21(2): 149-170. <https://doi.org/10.1177/109019819402100203>
- Ittmann, H. W. (2021). A bibliometric analysis of the Journal of Transport and Supply Chain Management. *Journal of Transport and Supply Chain Management* 15: 15. <https://doi.org/10.1080/15332667.2022.2080465>
- Jackson, T. L., Feddema, J. J., Oleson, K. W., Bonan, G. B., & Bauer, J. T. (2010). Parameterization of urban characteristics for global climate modeling. *Annals of the Association of American Geographers* 100(4): 848-865. <https://doi.org/10.1080/00045608.2010.497328>
- Jalali, Z., Ghaffarianhoseini, A., Ghaffarianhoseini, A., Donn, M., Almhafdy, A., Walker, C., & Berardi, U. (2022). What we know and do not know about New Zealand's urban microclimate: A critical review. *Energy and Buildings*: 112430. <https://doi.org/10.1016/j.enbuild.2022.112430>
- Jalali, Z., Shamseldin, A. Y., & Ghaffarianhoseini, A. (2024). Urban microclimate impacts on residential building energy demand in Auckland, New Zealand: A climate change perspective. *Urban Climate* 53: 101808. <https://doi.org/10.1016/j.uclim.2024.101808>
- Jamaludin, N., Mohammed, N. I., Khamidi, M. F., & Wahab, S. N. A. (2015). Thermal comfort of residential building in Malaysia at different micro-climates. *Procedia-Social and Behavioral Sciences* 170: 613-623. <https://doi.org/10.1016/j.sbspro.2015.01.063>
- Jamei, E., Ossen, D. R., & Rajagopalan, P. (2017). Investigating the effect of urban configurations on the variation of air temperature. *International Journal of Sustainable Built Environment* 6(2): 389-399. <https://doi.org/10.1016/j.ijjsbe.2017.07.001>
- Jamei, E., & Rajagopalan, P. (2019). Effect of street design on pedestrian thermal comfort. *Architectural Science Review* 62(2): 92-111. <https://doi.org/10.1080/00038628.2018.1537236>

- Jamei, E., Rajagopalan, P., Seyedmahmoudian, M., & Jamei, Y. (2016). Review on the impact of urban geometry and pedestrian level greening on outdoor thermal comfort. *Renewable and Sustainable Energy Reviews* 54: 1002-1017. <https://doi.org/10.1016/j.rser.2015.10.104>
- Jamei, E., Seyedmahmoudian, M., Horan, B., & Stojcevski, A. (2019). Verification of a bioclimatic modeling system in a growing suburb in Melbourne. *Science of the total Environment* 689: 883-898. <https://doi.org/10.1016/j.scitotenv.2019.06.399>
- Jamei, E., Abuseif, M., Ghaffarianhoseini, A., Ghaffarianhoseini, A. (2024). *Chapter 11 - Urban overheating governance on the mitigation and adaptation of anthropogenic heat emissions*. Mitigation and Adaptation of Urban Overheating. <https://doi.org/10.1016/B978-0-443-13502-6.00016-6>
- Janssen, W., Blocken, B., & Hooff, T. (2013). Pedestrian wind comfort around buildings: Comparison of wind comfort criteria based on whole-flow field data for a complex case study. *Building and Environment* 59: 547-562. <https://doi.org/10.1016/j.buildenv.2012.10.012>
- Jareemit, D., & Srivanit, M. (2019, September 21-23). *Effect of street canyon configurations and orientations on urban wind velocity in Bangkok Suburb Areas*. IOP Conference Series: Materials Science and Engineering, 690 012006, 2nd International Conference on Civil Engineering and Architecture, Seoul, South Korea. <https://doi.org/10.1088/1757-899X/690/1/012006>
- Javanroodi, K., & Nik, V. M. (2019). Impacts of microclimate conditions on the energy performance of buildings in urban areas. *Buildings* 9(8): 189. <https://doi.org/10.3390/buildings9080189>
- Jentsch, M., Bahaj, A., & James, P. (2013). CCWorldWeatherGen, Climate change world weather file generator, Version 1.8. *Sustainable Energy Research Group, The University of Southampton*.
- Jiao, Y., Yu, H., Wang, T., An, Y., & Yu, Y. (2017). Thermal comfort and adaptation of the elderly in free-running environments in Shanghai, China. *Building and Environment* 118: 259-272. <https://doi.org/10.1016/j.buildenv.2017.03.038>
- Jihad, A. S., & Tahiri, M. (2016). Modeling the urban geometry influence on outdoor thermal comfort in the case of Moroccan microclimate. *Urban Climate* 16: 25-42. <https://doi.org/10.1016/j.uclim.2016.02.002>
- Johansson, E. (2006). Influence of urban geometry on outdoor thermal comfort in a hot dry climate: A study in Fez, Morocco. *Building and Environment* 41(10): 1326-1338. <https://doi.org/10.1016/j.buildenv.2005.05.022>

- Johansson, E., & Emmanuel, R. (2006). The influence of urban design on outdoor thermal comfort in the hot, humid city of Colombo, Sri Lanka. *International Journal of Biometeorology* 51: 119-133. <https://doi.org/10.1007/s00484-006-0047-6>
- Johansson, E., & Emmanuel, R. (2006). The influence of urban design on outdoor thermal comfort in the hot, humid city of Colombo, Sri Lanka. *International Journal of Biometeorology* 51(2): 119-133. <https://doi.org/10.1007/s00484-006-0047-6>
- Johansson, E., Yahia, M. W., Arroyo, I., & Bengs, C. (2018). Outdoor thermal comfort in public space in warm-humid Guayaquil, Ecuador. *International Journal of Biometeorology* 62: 387-399. <https://doi.org/10.1007/s00484-017-1329-x>
- Jomehzadeh, F., Hussen, H. M., Calautit, J. K., Nejat, P., & Ferwati, M. S. (2020). Natural Ventilation by Windcatcher: A Review on the Impacts of Geometry, Microclimate and Macroclimate. *Energy and Buildings*: 110396. <https://doi.org/10.1016/j.enbuild.2020.110396>
- Joynt, J. L., & Golubiewski, N. (2019). *Development of the Auckland heat vulnerability index*. Auckland Council.
- Jura, J., Trnka, P., & Novak, M. (2019, May 23-24). *Empirical Identification of Surface Parameters Affecting the Microclimate*. Smart City Symposium Prague (SCSP), IEEE. <https://doi.org/10.1109/SCSP.2019.8805684>
- Kamal, A., Abidi, S. M. H., Mahfouz, A., Kadam, S., Rahman, A., Hassan, I. G., & Wang, L. L. (2021). Impact of urban morphology on urban microclimate and building energy loads. *Energy and Buildings* 253: 111499. <https://doi.org/10.1016/j.enbuild.2021.111499>
- Karimi, A., Sanaieian, H., Farhadi, H., & Norouzian-Maleki, S. (2020). Evaluation of the thermal indices and thermal comfort improvement by different vegetation species and materials in a medium-sized urban park. *Energy Reports* 6: 1670-1684. <https://doi.org/10.1016/j.egy.2020.06.015>
- Kaynak, H. (2003). The relationship between total quality management practices and their effects on firm performance. *Journal of Operations Management* 21(4): 405-435. [https://doi.org/10.1016/S0272-6963\(03\)00004-4](https://doi.org/10.1016/S0272-6963(03)00004-4)
- Kedissa, C., Outtas, S., & Belarbi, R. (2016). The impact of height/width ratio on the microclimate and thermal comfort levels of urban courtyards. *International Journal of Sustainable Building Technology and Urban Development* 7(3-4): 174-183. <https://doi.org/10.1080/2093761X.2017.1302830>
- Kenawy, I., & ElKadi, H. (2011). Diversity and thermal comfort in outdoor places. *International Journal of Diversity in Organizations, Communities, and Nations* 11(1): 237. <https://doi.org/10.18848/1447-9532/CGP/v11i01/38971>

- Kenawy, I., & Elkadi, H. (2018). The outdoor thermal benchmarks in Melbourne urban climate. *Sustainable Cities and Society* 43: 587-600. <https://doi.org/10.1016/j.scs.2018.09.004>
- Ketterer, C., & Matzarakis, A. (2014). Human-biometeorological assessment of heat stress reduction by replanning measures in Stuttgart, Germany. *Landscape and Urban Planning* 122: 78-88. <https://doi.org/10.1016/j.landurbplan.2013.11.003>
- Kidston, J., Renwick, J., & McGregor, J. (2009). Hemispheric-scale seasonality of the Southern Annular Mode and impacts on the climate of New Zealand. *Journal of Climate* 22(18): 4759-4770. <https://doi.org/10.1175/2009JCLI2640.1>
- Kim, H., & Macdonald, E. (2017). Measuring the effectiveness of San Francisco's planning standard for pedestrian wind comfort. *International Journal of Sustainable Development & World Ecology* 24(6): 502-511. <https://doi.org/10.1080/13504509.2016.1232319>
- Kim, S. W., & Brown, R. D. (2022). Pedestrians' behavior based on outdoor thermal comfort and micro-scale thermal environments, Austin, TX. *Science of the Total Environment* 808: 152143. <https://doi.org/10.1016/j.scitotenv.2021.152143>
- Kim, S. W., Lee, J. H., Lee, M. U., Lee, H. M., Lee, S. H., & Kim, Y. E. (2022). Analysis of the Incidence and Risk factors of Postoperative Delirium in Patients with Degenerative Cervical Myelopathy. *National Library of Medicine* 19(2): 323-333. <https://doi.org/10.14245/ns.2142778.389>
- Kitous, S., Bensalem, R., & Adolphe, L. (2012). Airflow patterns within a complex urban topography under hot and dry climate in the Algerian Sahara. *Building and Environment* 56: 162-175. <https://doi.org/10.1016/j.buildenv.2012.02.022>
- Kleerekoper, L., Van den Dobbelen, A., Hordijk, G., Van Dorst, M., & Martin, C. (2015). Climate adaptation strategies: achieving insight in microclimate effects of redevelopment options. *Smart and Sustainable Built Environment* 4(1): 110-136.
- Klemm, O., & Lin, N. (2016). What causes observed fog trends: air quality or climate change? *Aerosol and Air Quality Research* 16(5): 1131-1142. <https://doi.org/10.4209/aaqr.2015.05.0353>
- Klemm, W., Heusinkveld, B. G., Lenzholzer, S., Jacobs, M. H., & Van Hove, B. (2015). Psychological and physical impact of urban green spaces on outdoor thermal comfort during summertime in The Netherlands. *Building and Environment* 83: 120-128. <https://doi.org/10.1016/j.buildenv.2014.05.013>
- Klemm, W., Heusinkveld, B. G., Lenzholzer, S., & Van Hove B. (2015). Street greenery and its physical and psychological impact on thermal comfort. *Landscape and Urban Planning* 138: 87-98. <https://doi.org/10.1016/j.landurbplan.2015.02.009>

Klok, L., Rood, N., Kluck, J., & Kleerekoper, L. (2019). Assessment of thermally comfortable urban spaces in Amsterdam during hot summer days. *International Journal of Biometeorology* 63(2): 129-141. <https://doi.org/10.1007/s00484-018-1644-x>

Kong, S., Ji, Y., Liu, L., Chen, L., Zhao, X., Wang, J., Bai, Z., & Sun, Z. (2012). Diversities of phthalate esters in suburban agricultural soils and wasteland soil appeared with urbanization in China. *Environmental Pollution* 170: 161-168. <https://doi.org/10.1016/j.envpol.2012.06.017>

Koppen, W. (1936). Das geographische system der klimat. *Handbuch der klimatologie*: 46.

Köppen, W. (1884). Die Wärmezonen der Erde, nach der Dauer der heissen, gemässigten und kalten Zeit und nach der Wirkung der Wärme auf die organische Welt betrachtet. *Meteorologische Zeitschrift* 1(21): 5-226.

Kottek, M., Grieser, J., Beck, C., Rudolf, B., & Rubel, F. (2006). World map of the Köppen-Geiger climate classification updated. *Meteorologische Zeitschrift*,15: 259-263

Krebs, L. F., & Johansson, E. (2021). Influence of microclimate on the effect of green roofs in Southern Brazil—A study coupling outdoor and indoor thermal simulations. *Energy and Buildings* 241: 110963. <https://doi.org/10.1016/j.enbuild.2021.110963>

Krüger, E., Drach, P., & Broede, P. (2017). Outdoor comfort study in Rio de Janeiro: site-related context effects on reported thermal sensation. *International Journal of Biometeorology* 61(3): 463-475. <https://doi.org/10.1007/s00484-016-1226-8>

Krüger, E., Minella, F., & Rasia, F. (2011). Impact of urban geometry on outdoor thermal comfort and air quality from field measurements in Curitiba, Brazil. *Building and Environment* 46(3): 621-634. <https://doi.org/10.1016/j.buildenv.2010.09.006>

Krüger, E., Piaskowy, N., Moro, J., & Minella, F. (2019). Identifying solar access effects on visitors' behavior in outdoor resting areas in a subtropical location: a case study in Japan Square in Curitiba, Brazil. *International Journal of Biometeorology* 63: 301-313. <https://doi.org/10.1007/s00484-018-01664-z>

Kumar, P., & Sharma, A. (2020). Study on importance, procedure, and scope of outdoor thermal comfort—A review. *Sustainable Cities and Society* 61: 102297. <https://doi.org/10.1016/j.scs.2020.102297>

Künzel, H., Schmidt, T., & Holm, A. (2002, September 26-27). *Exterior surface temperature of different wall constructions comparison of numerical simulation and experiment*. Proceedings of 11th Symposium of Building Physics, Technische Universität Dresden, Dresden, Germany.

- Kuo, C.-Y., Wang, R.-J., Lin, Y.-P., & Lai, C.-M. (2020). Urban design with the wind: pedestrian-level wind field in the street canyons downstream of parallel high-rise buildings. *Energies* 13(11): 2827. <https://doi.org/10.3390/en13112827>
- Kwon, C. W., Lee, K. J., & Cho, S. (2019). Numerical study of balancing between indoor building energy and outdoor thermal comfort with a flexible building element. *Sustainability* 11(23): 6654. <https://doi.org/10.3390/su11236654>
- Kyle, G., Graefe, A., Manning, R., & Bacon, J. (2004). Effects of place attachment on users' perceptions of social and environmental conditions in a natural setting. *Journal of Environmental Psychology* 24(2): 213-225. <https://doi.org/10.1016/j.jenvp.2003.12.006>
- Lachapelle, J. A., Krayenhoff, E. S., Middel, A., Meltzer, S., Broadbent, A. M., & Georgescu, M. (2022). A microscale three-dimensional model of urban outdoor thermal exposure (TUF-Pedestrian). *International Journal of Biometeorology* 66(4): 833-848. <https://doi.org/10.1007/s00484-022-02241-1>
- Lai, A., Maing, M., & Ng, E. (2017). Observational studies of mean radiant temperature across different outdoor spaces under shaded conditions in densely built environment. *Building and Environment* 114: 397-409. <https://doi.org/10.1016/j.buildenv.2016.12.034>
- Lai, D., Liu, W., Gan, T., Liu, K., & Chen, Q. (2019). A review of mitigating strategies to improve the thermal environment and thermal comfort in urban outdoor spaces. *Science of the Total Environment* 661: 337-353. <https://doi.org/10.1016/j.scitotenv.2019.01.062>
- Lam, C. K. C., Cui, S., Liu, J., Kong, X., Ou, C., & Hang J. (2021). Influence of acclimatization and short-term thermal history on outdoor thermal comfort in subtropical South China. *Energy and Buildings* 231: 110541. <https://doi.org/10.1016/j.enbuild.2020.110541>
- Lam, C. K. C., Gao, Y., Yang, H., Chen, T., Zhang, Y., Ou, C., & Hang, J. (2021). Interactive effect between long-term and short-term thermal history on outdoor thermal comfort: Comparison between Guangzhou, Zhuhai and Melbourne. *Science of the Total Environment* 760: 144141. <https://doi.org/10.1016/j.scitotenv.2020.144141>
- Lam, C. K. C., & Lau, K. K.-L. (2018). Effect of long-term acclimatization on summer thermal comfort in outdoor spaces: a comparative study between Melbourne and Hong Kong. *International Journal of Biometeorology* 62: 1311-1324. <https://doi.org/10.1007/s00484-018-1535-1>
- Lam, C. K. C., Lee, H., Yang, S.-R., & Park, S. (2021). A review on the significance and perspective of the numerical simulations of outdoor thermal environment. *Sustainable Cities and Society* 71: 102971. <https://doi.org/10.1016/j.scs.2021.102971>

- Lam, C. K. C., Lee, H., Yang, S.-R., & Park, S. (2021). A review on the significance and perspective of the numerical simulations of outdoor thermal environment. *Sustainable Cities and Society*: 102971. <https://doi.org/10.1016/j.scs.2021.102971>
- Lam, C. K. C., Loughnan, M., & Tapper, N. (2018). Visitors' perception of thermal comfort during extreme heat events at the Royal Botanic Garden Melbourne. *International Journal of Biometeorology* 62: 97-112. <https://doi.org/10.1007/s00484-015-1125-4>
- Lau, K. K.-L., Chung, S. C., & Ren, C. (2019). Outdoor thermal comfort in different urban settings of sub-tropical high-density cities: An approach of adopting local climate zone (LCZ) classification. *Building and Environment* 154: 227-238. <https://doi.org/10.1016/j.buildenv.2019.03.005>
- Lau, K. K.-L., Ng, E., Ren, C., Ho, J. C.-K., Wan, L., Shi, Y., Zheng, Y., Gong, F., Cheng, V., & Yuan, C. (2018). Defining the environmental performance of neighbourhoods in high-density cities. *Building Research & Information* 46(5): 540-551. <https://doi.org/10.1080/09613218.2018.1399583>
- Lau, K. K.-L., Shi, Y., & Ng, E. Y.-Y. (2019). Dynamic response of pedestrian thermal comfort under outdoor transient conditions. *International Journal of Biometeorology* 63: 979-989. <https://doi.org/10.1007/s00484-019-01712-2>
- Lau, K. K. L., Ng, E., Ren, C., Ho, J. C. K., Wan, L., Shi, Y., Zheng, Y., Gong, F., Cheng, V., Yuan, C., Tan, Z., & Wong, S. (2018). Defining the environmental performance of neighbourhoods in high-density cities. *Building Research and Information* 46(5): 540-551. <https://doi.org/10.1080/09613218.2018.1399583>
- Lau, S. S. Y., Gou, Z., & Liu, Y. (2014). Healthy campus by open space design: Approaches and guidelines. *Frontiers of Architectural Research* 3(4): 452-467. <https://doi.org/10.1016/j.foar.2014.06.006>
- Laureti, F., Martinelli, L., & Battisti, A. (2018). Assessment and mitigation strategies to counteract overheating in urban historical areas in Rome. *Climate* 6(1): 18. <https://doi.org/10.3390/cli6010018>
- Leal Filho, W., Wolf, F., Castro-Díaz, R., Li, C., Ojeh, V. N., Gutiérrez, N., Nagy, G. J., Savić, S., Natenzon, C. E., & Quasem Al-Amin, A. (2021). Addressing the urban heat islands effect: A cross-country assessment of the role of green infrastructure. *Sustainability* 13(2): 753. <https://doi.org/10.3390/su13020753>
- Lee, H., & Mayer, H. (2016). Validation of the mean radiant temperature simulated by the RayMan software in urban environments. *International Journal of Biometeorology* 60(11): 1775-1785. <https://doi.org/10.1007/s00484-016-1166-3>

- Lee, H., & Mayer, H. (2018). Maximum extent of human heat stress reduction on building areas due to urban greening. *Urban Forestry & Urban Greening* 32: 154-167. <https://doi.org/10.1016/j.ufug.2018.04.010>
- Lee, H., & Mayer, H. (2018). Thermal comfort of pedestrians in an urban street canyon is affected by increasing albedo of building walls. *International Journal of Biometeorology* 62(7): 1199-1209. <https://doi.org/10.1007/s00484-018-1523-5>
- Lee, H., Mayer, H., & Kuttler, W. (2019). To what extent does the air flow initialisation of the ENVI-met model affect human heat stress simulated in a common street canyon? *International Journal of Biometeorology* 63: 73-81. <https://doi.org/10.1007/s00484-018-1637-9>
- Lee, L. S., Cheung, P. K., Fung, C. K., & Jim, C. Y. (2020). Improving street walkability: Biometeorological assessment of artificial-partial shade structures in summer sunny conditions. *International Journal of Biometeorology* 64(4): 547-560. <https://doi.org/10.1007/s00484-019-01840-9>
- Lehnert, M., Tokar, V., Jurek, M., & Geletič, J. (2021). Summer thermal comfort in Czech cities: measured effects of blue and green features in city centres. *International Journal of Biometeorology* 65(8): 1277-1289. <https://doi.org/10.1007/s00484-020-02010-y>
- Lemonsu, A., Amossé, A., Chouillou, D., Gaudio, Haouès-Jouve N., Hidalgo, J., Le Bras, J., Legain, D., Marchandise, S., & Tudoux, B. (2020). Comparison of microclimate measurements and perceptions as part of a global evaluation of environmental quality at neighbourhood scale. *International Journal of Biometeorology* 64(2): 265-276. <https://doi.org/10.1007/s00484-019-01686-1>
- Leng, H., Liang, S., & Yuan, Q. (2020). Outdoor thermal comfort and adaptive behaviors in the residential public open spaces of winter cities during the marginal season. *International Journal of Biometeorology* 64: 217-229. <https://doi.org/10.1007/s00484-019-01709-x>
- Li, J., Niu, J., Mak, C. M., Huang, T., & Xie, Y. (2018). Assessment of outdoor thermal comfort in Hong Kong based on the individual desirability and acceptability of sun and wind conditions. *Building and Environment* 145: 50-61. <https://doi.org/10.1016/j.buildenv.2018.08.059>
- Li, J., Qi, M., Duan, Q., Huo, L., & Wang, J. (2018). Towards Pedestrian Microclimatic Comfort: A Rapid Predication Model for Street Winds and Pedestrian Thermal Sensation. *Nano Life* 8(02): 1840006. <https://doi.org/10.1142/S1793984418400068>
- Li, K., Zhang, Y., & Zhao, L. (2016). Outdoor thermal comfort and activities in the urban residential community in a humid subtropical area of China. *Energy and Buildings* 133: 498-511. <https://doi.org/10.1016/j.enbuild.2016.10.013>

- Li, X.-X., & Norford, L. K. (2016). Evaluation of cool roof and vegetations in mitigating urban heat island in a tropical city, Singapore. *Urban Climate* 16: 59-74. <https://doi.org/10.1016/j.uclim.2015.12.002>
- Li, Y., Zhang, X., Zhao, X., Ma, S., Cao, H., & Cao, J. (2016). Assessing spatial vulnerability from rapid urbanization to inform coastal urban regional planning. *Ocean & Coastal Management* 123: 53-65. <https://doi.org/10.1016/j.ocecoaman.2016.01.010>
- Lin, J., & Brown, R. D. (2021). Integrating microclimate into landscape architecture for outdoor thermal comfort: a systematic review. *Land* 10(2): 196. <https://doi.org/10.3390/land10020196>
- Lin, P., Lau, S. S. Y., Qin, H., & Gou, Z. (2017). Effects of urban planning indicators on urban heat island: a case study of pocket parks in high-rise high-density environment. *Landscape and Urban Planning* 168: 48-60. <https://doi.org/10.1016/j.landurbplan.2017.09.024>
- Lin, T.-P. (2009). Thermal perception, adaptation and attendance in a public square in hot and humid regions. *Building and Environment* 44(10): 2017-2026. <https://doi.org/10.1016/j.buildenv.2009.02.004>
- Lin, T.-P., & Matzarakis, A. (2008). Tourism climate and thermal comfort in Sun Moon Lake, Taiwan. *International Journal of Biometeorology* 52(4): 281-290. <https://doi.org/10.1007/s00484-007-0122-7>
- Lin, T.-P., & Matzarakis, A. (2008). Tourism climate and thermal comfort in Sun Moon Lake, Taiwan. *International Journal of Biometeorology* 52: 281-290. <https://doi.org/10.1007/s00484-007-0122-7>
- Lin, T.-P., Matzarakis, A., & Hwang, R.-L. (2010). Shading effect on long-term outdoor thermal comfort. *Building and Environment* 45(1): 213-221. <https://doi.org/10.1016/j.buildenv.2009.06.002>
- Littlefair, P. (1998). Passive solar urban design: ensuring the penetration of solar energy into the city. *Renewable and Sustainable Energy Reviews* 2(3): 303-326. [https://doi.org/10.1016/S1364-0321\(97\)00009-9](https://doi.org/10.1016/S1364-0321(97)00009-9)
- Liu, S., Nazarian, N., Hart, M. A., Niu, J., Xie, Y., & Dear, R. de (2021). Dynamic thermal pleasure in outdoor environments-temporal alliesthesia. *Science of The Total Environment* 771: 144910. <https://doi.org/10.1016/j.scitotenv.2020.144910>
- Liu, W., Zhang, Y., & Deng, Q. (2016). The effects of urban microclimate on outdoor thermal sensation and neutral temperature in hot-summer and cold-winter climate. *Energy and Buildings* 128: 190-197. <https://doi.org/10.1016/j.enbuild.2016.06.086>

- Liu, Y., Li, Q., Yang, L., Mu, K., Zhang, M., & Liu, J. (2020). Urban heat island effects of various urban morphologies under regional climate conditions. *Science of the Total Environment* 743: 140589. <https://doi.org/10.1016/j.scitotenv.2020.140589>
- Liu, Z., Zheng, S., & Zhao, L. (2018). Evaluation of the ENVI-Met vegetation model of four common tree species in a subtropical hot-humid area. *Atmosphere* 9(5): 198. <https://doi.org/10.3390/atmos9050198>
- Lobaccaro, G., & Acero, J. A. (2015). Comparative analysis of green actions to improve outdoor thermal comfort inside typical urban street canyons. *Urban Climate* 14: 251-267. <https://doi.org/10.1016/j.uclim.2015.10.002>
- Lobaccaro, G., Acero, J. A., Sanchez Martinez, G., Padro, A., Laburu, T., & Fernandez, G. (2019). Effects of orientations, aspect ratios, pavement materials and vegetation elements on thermal stress inside typical urban canyons. *International Journal of Environmental Research and Public Health* 16(19): 3574. <https://doi.org/10.3390/ijerph16193574>
- Lobaccaro, G., Croce, S., Vettorato, D., & Carlucci, S. (2018). A holistic approach to assess the exploitation of renewable energy sources for design interventions in the early design phases. *Energy and Buildings* 175: 235-256. <https://doi.org/10.1016/j.enbuild.2018.06.066>
- Long, Y., & Wu, K. (2016). Shrinking cities in a rapidly urbanizing China. *Environment and Planning A* 48(2): 220-222. <https://doi.org/10.1177/0308518X15621631>
- López-Cabeza, V., Galán-Marín, C., Rivera-Gómez, C., & Roa-Fernández, J. (2018). Courtyard microclimate ENVI-met outputs deviation from the experimental data. *Building and Environment* 144: 129-141. <https://doi.org/10.1016/j.buildenv.2018.08.013>
- Lorrey, A., & Bostock, H. (2017). The climate of New Zealand through the Quaternary. *Landscape and quaternary environmental change in New Zealand*: 67-139. https://doi.org/10.2991/978-94-6239-237-3_3
- Lorrey, A. M., Griffiths, G., Fauchereau, N., Diamond, H. J., Chappell, P. R., & Renwick, J. (2014). An ex-tropical cyclone climatology for Auckland, New Zealand. *International Journal of Climatology* 34(4): 1157-1168. <https://doi.org/10.1002/joc.3753>
- Lu, J., Li, Q., Zeng, L., Chen, J., Liu, G., Li, Y., Li, W., & Huang, K. (2017). A micro-climatic study on cooling effect of an urban park in a hot and humid climate. *Sustainable Cities and Society* 32: 513-522. <https://doi.org/10.1016/j.scs.2017.04.017>
- Ma, D., Carpenter, N., Maki, H., Rehman, T. U., Tuinstra, M. R., & Jin, J. (2019). Greenhouse environment modeling and simulation for microclimate control. *Computers and Electronics in Agriculture* 162: 134-142. <https://doi.org/10.1016/j.compag.2019.04.013>

- Ma, X., Fukuda, H., Zhou, D., & Wang, M. (2019). A Study of the Pedestrianized Zone for Tourists: Urban Design Effects on Humans' Thermal Comfort in Fo Shan City, Southern China. *Sustainability* 11(10): 2774. <https://doi.org/10.3390/su11102774>
- Ma, X., Wang, M., Zhao, J., Zhang, L., & Liu, W. (2020). Performance of different urban design parameters in improving outdoor thermal comfort and health in a pedestrianized zone. *International Journal of Environmental Research and Public Health* 17(7): 2258. <https://doi.org/10.3390/ijerph17072258>
- MacLeod, A., & Korycinska, A. (2019). Detailing Köppen–Geiger climate zones at sub-national to continental scale: a resource for pest risk analysis. *EPPO Bulletin* 49(1): 73-82. <https://doi.org/10.1111/epp.12549>
- Makaremi, N., Salleh, E., Jaafar, M. Z., & GhaffarianHoseini, A. (2012). Thermal comfort conditions of shaded outdoor spaces in hot and humid climate of Malaysia. *Building and Environment* 48: 7-14. <https://doi.org/10.1016/j.buildenv.2011.07.024>
- Makropoulou, M. (2017). Microclimate improvement of Inner-City urban areas in a Mediterranean coastal city. *Sustainability* 9(6): 882. <https://doi.org/10.3390/su9060882>
- Mannetje, A. t., Eng, A., Walls, C., Dryson, E., Douwes, J., Bertazzi, P., Ryder-Lewis, S., Scott, D., Brooks, C., & McLean, D. (2018). Morbidity in New Zealand pesticide producers exposed to 2, 3, 7, 8-tetrachlorodibenzo-p-dioxin (TCDD). *Environment International* 110: 22-31. <https://doi.org/10.1016/j.envint.2017.09.018>
- Marando, F., Salvatori, E., Sebastiani, A., Fusaro, L., & Manes, F. (2019). Regulating ecosystem services and green infrastructure: Assessment of urban heat island effect mitigation in the municipality of Rome, Italy. *Ecological Modelling* 392: 92-102. <https://doi.org/10.1016/j.ecolmodel.2018.11.011>
- Martinelli, L., Lin, T.-P., & Matzarakis, A. (2015). Assessment of the influence of daily shadings pattern on human thermal comfort and attendance in Rome during summer period. *Building and Environment* 92: 30-38. <https://doi.org/10.1016/j.buildenv.2015.04.013>
- Martinelli, L., & Matzarakis, A. (2017). Influence of height/width proportions on the thermal comfort of courtyard typology for Italian climate zones. *Sustainable Cities and Society* 29: 97-106. <https://doi.org/10.1016/j.scs.2016.12.004>
- Martini, A., Biondi, D., & Batista, A. C. (2020). Thermal comfort provided by street trees in cities. *Arboricultural Journal* 42(3): 153-164. <https://doi.org/10.1080/03071375.2020.1755187>
- Martins, T. A., Adolphe, L., Bonhomme, M., Bonneaud, F., Faraut, S., Ginestet, S., Michel, C., & Guyard, W. (2016). Impact of Urban Cool Island measures on outdoor climate and pedestrian

comfort: simulations for a new district of Toulouse, France. *Sustainable Cities and Society* 26: 9-26. <https://doi.org/10.1016/j.scs.2016.05.003>

Martins, T. A. L., Adolphe, L., Bonhomme, M., Bonneaud, S., Faraut, S., Ginestet, C., Michel, C., & Guyard, W. (2016). Impact of Urban Cool Island measures on outdoor climate and pedestrian comfort: Simulations for a new district of Toulouse, France. *Sustainable Cities and Society* 26: 9-26. <https://doi.org/10.1016/j.scs.2016.05.003>

Mason, E. G., Salekin, S., & Morgenroth, J. A. (2017). Comparison between meteorological data from the New Zealand National Institute of Water and Atmospheric Research (NIWA) and data from independent meteorological stations. *New Zealand Journal of Forestry Science* 47(1): 1-8. <https://doi.org/10.1186/s40490-017-0088-0>

Mason, S. (2018). Publications in the doctoral thesis: Challenges for doctoral candidates, supervisors, examiners and administrators. *Higher Education Research & Development* 37(6): 1231-1244. <https://doi.org/10.1080/07294360.2018.1462307>

Masson, V., Heldens, W., Bocher, E., Bonhomme, M., Bucher, B., Burmeister, C., de Munck, C., Esch, T., Hidalgo, J., & Kanani-Sühring, F. (2020). City-descriptive input data for urban climate models: Model requirements, data sources and challenges. *Urban Climate* 31: 100536. <https://doi.org/10.1016/j.uclim.2019.100536>

Matallah, M. E., Mahar, W. A., Bughio, M., Alkama, D., Ahriz, A., & Bouzaher S. (2021). Prediction of climate change effect on outdoor thermal comfort in arid region. *Energies* 14(16): 4730. <https://doi.org/10.3390/en14164730>

Matas, C. P. (2012). Doctoral education and skills development: An international perspective. *REDU: Revista de Docencia Universitaria* 10(2): 163.

Matasov, V., Belelli Marchesini, L., Yaroslavtsev, A., Sala, G., Fareeva, O., Seregin, I., Castaldi, S., Vasenev, V., & Valentini, R. (2020). Iot monitoring of urban tree ecosystem services: Possibilities and challenges. *Forests* 11(7): 775. <https://doi.org/10.3390/f11070775>

Mauree, D., Coccolo, S., & Scartezzini, J.-L. (2019, September 4-6). *Impact of evapotranspiration on the local microclimate*. Journal of Physics: Conference Series, IOP Publishing, 1343 012009. <https://doi.org/10.1088/1742-6596/1343/1/012009>

Mauree, D., Naboni, E., Coccolo, S., Perera, A. T. D., Nik, V. M., & Scartezzini, J.-L. (2019). A review of assessment methods for the urban environment and its energy sustainability to guarantee climate adaptation of future cities. *Renewable and Sustainable Energy Reviews* 112: 733-746. <https://doi.org/10.1016/j.rser.2019.06.005>

- McGlone, M. (2002). The Late Quaternary peat, vegetation and climate history of the Southern Oceanic Islands of New Zealand. *Quaternary Science Reviews* 21(4-6): 683-707. [https://doi.org/10.1016/S0277-3791\(01\)00044-0](https://doi.org/10.1016/S0277-3791(01)00044-0)
- Mehrotra, S., Bardhan, R., & Ramamritham, K. (2019). Outdoor thermal performance of heterogeneous urban environment: An indicator-based approach for climate-sensitive planning. *Science of the Total Environment* 669: 872-886. <https://doi.org/10.1016/j.scitotenv.2019.03.152>
- Meili, N., Acero, J. A., Peleg, N., Manoli, G., Burlando, P., & Fatichi, S. (2021). Vegetation cover and plant-trait effects on outdoor thermal comfort in a tropical city. *Building and Environment* 195: 107733. <https://doi.org/10.1016/j.buildenv.2021.107733>
- Meili, N., Manoli, G., Burlando, P., Carmeliet, J., Chow, W. T., Coutts, A. M., Roth, M., Velasco, E., Vivoni, E. R., & Fatichi, S. (2021). Tree effects on urban microclimate: Diurnal, seasonal, and climatic temperature differences explained by separating radiation, evapotranspiration, and roughness effects. *Urban Forestry & Urban Greening* 58: 126970. <https://doi.org/10.1016/j.ufug.2020.126970>
- Merga, M. K. (2015). Thesis by publication in education: An autoethnographic perspective for educational researchers. *Issues in Educational Research* 25(3): 291-308.
- Mi, J., Hong, B., Zhang, T., Huang, B., & Niu, J. (2020). Outdoor thermal benchmarks and their application to climate-responsive designs of residential open spaces in a cold region of China. *Building and Environment* 169: 106592. <https://doi.org/10.1016/j.buildenv.2019.106592>
- Milošević, D. D., Bajšanski, I. V., & Savić, S. M. (2017). Influence of changing trees locations on thermal comfort on street parking lot and footways. *Urban Forestry & Urban Greening* 23: 113-124. <https://doi.org/10.1016/j.ufug.2017.03.011>
- Mirzaei, P. A. (2015). Recent challenges in modeling of urban heat island. *Sustainable Cities and Society* 19: 200-206. <https://doi.org/10.1016/j.scs.2015.04.001>
- Mirzaei, P. A. (2021). CFD modeling of micro and urban climates: Problems to be solved in the new decade. *Sustainable Cities and Society* 69: 102839. <https://doi.org/10.1016/j.scs.2021.102839>
- Mirzaei, P. A., & Carmeliet, J. (2013). Dynamical computational fluid dynamics modeling of the stochastic wind for application of urban studies. *Building and Environment* 70: 161-170. <https://doi.org/10.1016/j.buildenv.2013.08.014>

- Mitterboeck, M., & Korjenic, A. (2017). Analysis for improving the passive cooling of building's surroundings through the creation of green spaces in the urban built-up area. *Energy and Buildings* 148: 166-181. <https://doi.org/10.1016/j.enbuild.2017.02.005>
- Mohammad, P., Aghlmand, S., Fadaei, A., Gachkar, S., Gachkar, D., & Karimi, A. (2021). Evaluating the role of the albedo of material and vegetation scenarios along the urban street canyon for improving pedestrian thermal comfort outdoors. *Urban Climate* 40: 100993. <https://doi.org/10.1016/j.uclim.2021.100993>
- Mohsen, H., Raslan, R., & El-Bastawissi, I. (2020). Evaluating the transformation of land use and morphology on the microclimate: the case of gemmayzeh neighbourhood–Beirut. *BAU Journal-Health and Wellbeing* 3(1): 11.
- Montazeri, H., & Blocken, B. (2013). CFD simulation of wind-induced pressure coefficients on buildings with and without balconies: Validation and sensitivity analysis. *Building and Environment* 60: 137-149. <https://doi.org/10.1016/j.buildenv.2012.11.012>
- Montazeri, H., Toparlar, Y., Blocken, B., & Hensen, J. (2017). Simulating the cooling effects of water spray systems in urban landscapes: A computational fluid dynamics study in Rotterdam, The Netherlands. *Landscape and Urban Planning* 159: 85-100. <https://doi.org/10.1016/j.landurbplan.2016.10.001>
- Morakinyo, T. E., Kong, L., Lau, K. K.-L., Yuan, C., & Ng, E. (2017). A study on the impact of shadow-cast and tree species on in-canyon and neighborhood's thermal comfort. *Building and Environment* 115: 1-17. <https://doi.org/10.1016/j.buildenv.2017.01.005>
- Morakinyo, T. E., Lai, A., Lau, K. K.-L., & Ng, E. (2019). Thermal benefits of vertical greening in a high-density city: Case study of Hong Kong. *Urban Forestry & Urban Greening* 37: 42-55. <https://doi.org/10.1016/j.ufug.2017.11.010>
- Morakinyo, T. E., Lau, K. K.-L., Ren, C., & Ng, E. (2018). Performance of Hong Kong's common trees species for outdoor temperature regulation, thermal comfort and energy saving. *Building and Environment* 137: 157-170. <https://doi.org/10.1016/j.buildenv.2018.04.012>
- Morakinyo, T. E., Ouyang, W., Lau, K. K.-L., Ren, C., & Ng, E. (2020). Right tree, right place (urban canyon): Tree species selection approach for optimum urban heat mitigation-development and evaluation. *Science of the Total Environment* 719: 137461. <https://doi.org/10.1016/j.scitotenv.2020.137461>
- Morille, B., & Musy, M. (2017). Comparison of the impact of three climate adaptation strategies on summer thermal comfort–Cases study in Lyon, France. *Procedia Environmental Sciences* 38: 619-626. <https://doi.org/10.1016/j.proenv.2017.03.141>

- Mosbrugger, V., Utescher, T., & Dilcher, D. L. (2005). Cenozoic continental climatic evolution of Central Europe. *Proceedings of the National Academy of Sciences* 102(42): 14964-14969. <https://doi.org/10.1073/pnas.0505267102>
- Moss, R. H., Edmonds, J. A., Hibbard, K. A., Manning, M. R., Rose, S. K., Van Vuuren, D. P., Carter, T. R., Emori, S., Kainuma, M., & Kram, T. (2010). The next generation of scenarios for climate change research and assessment. *Nature* 463(7282): 747-756. <https://doi.org/10.1038/nature08823>
- Motazedian, A., Coutts, A. M., & Tapper, N. J. (2020). The microclimatic interaction of a small urban park in central Melbourne with its surrounding urban environment during heat events. *Urban Forestry & Urban Greening* 52: 126688. <https://doi.org/10.1016/j.ufug.2020.126688>
- Mullan, B., Salinger, J., Renwick, J., & Wratt, D. (2018). Comment on A Reanalysis of long-term surface air temperature trends in New Zealand. *Environmental Modeling & Assessment* 23: 249-262. <https://doi.org/10.1007/s10666-018-9606-6>
- Mullan, B., Sood, A., Stuart, S., & Carey-Smith, T. (2016). Climate change projections for New Zealand: atmosphere projections based on simulations from the IPCC fifth assessment. *Wellington, Ministry for the Environment*.
- Müller, N., Kuttler, W., & Barlag, A.-B. (2014). Counteracting urban climate change: adaptation measures and their effect on thermal comfort. *Theoretical and Applied Climatology* 115: 243-257. <https://doi.org/10.1007/s00704-013-0890-4>
- Muniz-Gaal, L. P., Pezzuto, C. C., de Carvalho, M. F. H., & Mota, L. T. M. (2020). Urban geometry and the microclimate of street canyons in tropical climate. *Building and Environment* 169: 106547. <https://doi.org/10.1016/j.buildenv.2019.106547>
- Mutani, G., & Todeschi, V. (2020). The effects of green roofs on outdoor thermal comfort, urban heat island mitigation and energy savings. *Atmosphere* 11(2): 123. <https://doi.org/10.3390/atmos11020123>
- Naboni, E., Meloni, M., Coccolo, S., Kaempf, J., & Scartezzini, J.-L. (2017). An overview of simulation tools for predicting the mean radiant temperature in an outdoor space. *Energy Procedia* 122: 1111-1116. <https://doi.org/10.1016/j.egypro.2017.07.471>
- Najafi, M., & Shariff, M. K. B. M. (2011). The concept of place and sense of place in architectural studies. *International Journal of Humanities and Social Sciences* 5(8): 1054-1060.
- Nasrollahi, N., Namazi, Y., & Taleghani, M. (2021). The effect of urban shading and canyon geometry on outdoor thermal comfort in hot climates: A case study of Ahvaz, Iran. *Sustainable Cities and Society* 65: 102638. <https://doi.org/10.1016/j.scs.2020.102638>

- Natanian, J., Aleksandrowicz, O., & Auer, T. (2019). A parametric approach to optimizing urban form, energy balance and environmental quality: The case of Mediterranean districts. *Applied Energy* 254: 113637. <https://doi.org/10.1016/j.apenergy.2019.113637>
- Natanian, J., Kastner, P., Dogan, T., & Auer, T. (2020). From energy performative to livable Mediterranean cities: An annual outdoor thermal comfort and energy balance cross-climatic typological study. *Energy and Buildings* 224: 110283. <https://doi.org/10.1016/j.enbuild.2020.110283>
- Nazarian, N., Sin, T., & Norford, L. (2018). Numerical modeling of outdoor thermal comfort in 3D. *Urban climate* 26: 212-230. <https://doi.org/10.1016/j.uclim.2018.09.001>
- Ng, A. W., Muttill, N., Balany, F., & Zegeye, B. (2020). Comparative Study of Thermal Comfort Indices: A Melbourne CBD Case Study. *Preprints, Semantic scholar*, 2020110613. <https://doi.org/10.20944/preprints202011.0613.v1>
- Ng, E., Chen, L., Wang, Y., & Yuan, C. (2012). A study on the cooling effects of greening in a high-density city: An experience from Hong Kong. *Building and Environment* 47: 256-271. <https://doi.org/10.1016/j.buildenv.2011.07.014>
- Ng, E., Yuan, C., Chen, L., Ren, C., & Fung, J. C. (2011). Improving the wind environment in high-density cities by understanding urban morphology and surface roughness: A study in Hong Kong. *Landscape and Urban Planning* 101(1): 59-74. <https://doi.org/10.1016/j.landurbplan.2011.01.004>
- Nielsen, C. N., & Kolarik, J. (2021, August 25-27). *Utilization of Climate Files Predicting Future Weather in Dynamic Building Performance Simulation—A review*. Journal of Physics: Conference Series, IOP Publishing, 2069 012070, Copenhagen, Denmark. <https://doi.org/10.1088/1742-6596/2069/1/012070>
- Nieuwenhuijsen, M. J. (2021). New urban models for more sustainable, liveable and healthier cities post covid19; reducing air pollution, noise and heat island effects and increasing green space and physical activity. *Environment International* 157: 106850. <https://doi.org/10.1016/j.envint.2021.106850>
- Nikolopoulou, M., Baker, N., & Steemers, K. (2001). Thermal comfort in outdoor urban spaces: understanding the human parameter. *Solar Energy* 70(3): 227-235. [https://doi.org/10.1016/S0038-092X\(00\)00093-1](https://doi.org/10.1016/S0038-092X(00)00093-1)
- Nikolopoulou, M., & Steemers, K. (2003). Thermal comfort and psychological adaptation as a guide for designing urban spaces. *Energy and Buildings* 35(1): 95-101. [https://doi.org/10.1016/S0378-7788\(02\)00084-1](https://doi.org/10.1016/S0378-7788(02)00084-1)

- Niu, J., Liu, J., Lee, T.-c., Lin, Z. J., Mak, C., Tse, K.-T., Tang, B.-s., & Kwok, K. C. (2015). A new method to assess spatial variations of outdoor thermal comfort: Onsite monitoring results and implications for precinct planning. *Building and Environment* 91: 263-270. <https://doi.org/10.1016/j.buildenv.2015.02.017>
- Norton, B. A., Coutts, A. M., Livesley, S. J., Harris, R. J., Hunter, A. M., & Williams, N. S. (2015). Planning for cooler cities: A framework to prioritise green infrastructure to mitigate high temperatures in urban landscapes. *Landscape and Urban Planning* 134: 127-138. <https://doi.org/10.1016/j.landurbplan.2014.10.018>
- Nouri, A. N. L. d. S. (2018). Addressing urban outdoor thermal comfort thresholds through public space design. *University of Lisbon, Faculty of Architecture*
- Nouri, A. S. (2015). A framework of thermal sensitive urban design benchmarks: Potentiating the longevity of auckland's public realm. *Buildings* 5(1): 252-281. <https://doi.org/10.3390/buildings5010252>
- Nouri, A. S., Lopes, A., Costa, J. P., & Matzarakis, A. (2018). Confronting potential future augmentations of the physiologically equivalent temperature through public space design: The case of Rossio, Lisbon. *Sustainable Cities and Society* 37: 7-25. <https://doi.org/10.1016/j.scs.2017.10.031>
- Oberascher, M., Kinzel, C., Kastlunger, U., Schöpf, M., Grimm, K., Plaiasu, D., Rauch, W., & Sitzenfrie, R. (2022). Smart water campus—a testbed for smart water applications. *Water Science & Technology* 86(11): 2834-2847. <https://doi.org/10.2166/wst.2022.369>
- Oke, T. R. (1982). The energetic basis of the urban heat island. *Quarterly Journal of the Royal Meteorological Society* 108(455): 1-24.
- Oke, T. R. (1988). Street design and urban canopy layer climate. *Energy and Buildings* 11(1-3): 103-113. [https://doi.org/10.1016/0378-7788\(88\)90026-6](https://doi.org/10.1016/0378-7788(88)90026-6)
- Olawumi, T. O., & Chan, D. W. (2018). A scientometric review of global research on sustainability and sustainable development. *Journal of cleaner production* 183: 231-250. <https://doi.org/10.1016/j.jclepro.2018.02.162>
- Othmer, F. J., Schmitt, J. P., & Greiving, S. (2020). Numerical modelling of the urban climate as an integrated part of environmental assessments. *Science of The Total Environment* 731: 138774. <https://doi.org/10.1016/j.scitotenv.2020.138774>
- Ouyang, W., Morakinyo, T. E., Ren, C., Liu, S., & Ng, E. (2021). Thermal-irradiant performance of green infrastructure typologies: Field measurement study in a subtropical climate city. *Science of The Total Environment* 764: 144635. <https://doi.org/10.1016/j.scitotenv.2020.144635>

- Ouyang, W., Morakinyo, T. E., Ren, C., & Ng, E. (2020). The cooling efficiency of variable greenery coverage ratios in different urban densities: A study in a subtropical climate. *Building and Environment* 174: 106772. <https://doi.org/10.1016/j.buildenv.2020.106772>
- Pantusheva, M., Mitkov, R., Hristov, P. O., & Petrova-Antonova, D. (2022). Air Pollution Dispersion Modelling in Urban Environment Using CFD: A Systematic Review. *Atmosphere* 13(10): 1640. <https://doi.org/10.3390/atmos13101640>
- Paranunzio, R., Dwyer, E., Fitton, J. M., Alexander, P. J., & O'Dwyer, B. (2021). Assessing current and future heat risk in Dublin city, Ireland. *Urban Climate* 40: 100983. <https://doi.org/10.1016/j.uclim.2021.100983>
- Passel, J. S., & D'Vera Cohn, D. (2008). *US population projections, 2005-2050*, Pew Research Center Washington, DC.
- Peduzzi, P., Dao, H., Herold, C., & Mouton, F. (2009). Assessing global exposure and vulnerability towards natural hazards: the Disaster Risk Index. *Natural Hazards and Earth System Sciences* 9(4): 1149-1159. <https://doi.org/10.5194/nhess-9-1149-2009>
- Peel, M. C., Finlayson, B. L., & McMahon, T. A. (2007). Updated world map of the Köppen-Geiger climate classification. *Hydrology and Earth System Sciences* 11(5): 1633-1644. <https://doi.org/10.5194/hess-11-1633-2007>
- Perera, K., Donn, M., & Schnabel, M. A. (2020, November 26-27). *Outdoor thermal comfort: A model based on thermal adaptation in New Zealand*. 54th International Conference of the Architectural Science Association (ANZAScA): 845-854, Auckland, New Zealand.
- Pham, T. (2020). On the relationship between total quality management practices and firm performance in Vietnam: The mediating role of non-financial performance. *Management Science Letters* 10(8): 1743-1754.
- Pigliautile, I., Chàfer, M., Pisello, A. L., Pérez, G., & Cabeza, L. F. (2020). Inter-building assessment of urban heat island mitigation strategies: Field tests and numerical modelling in a simplified-geometry experimental set-up. *Renewable Energy* 147: 1663-1675. <https://doi.org/10.1016/j.renene.2019.09.082>
- Pirooz, A. A., Li, Y., & Flay, R. G. (2020). Numerical and wind-tunnel investigation of wind flow over urban areas. *Structural Engineering Society New Zealand Journal* 33(1): 47-56.
- Pisello, A. L., Castaldo, V. L., Piselli, C., Fabiani, C., & Cotana, F. (2016). How peers' personal attitudes affect indoor microclimate and energy need in an institutional building: Results from a continuous monitoring campaign in summer and winter conditions. *Energy and Buildings* 126: 485-497. <https://doi.org/10.1016/j.enbuild.2016.05.053>

- Potchter, O., Cohen, P., Lin, T.-P., & Matzarakis, A. (2018). Outdoor human thermal perception in various climates: A comprehensive review of approaches, methods and quantification. *Science of the Total Environment* 631: 390-406. <https://doi.org/10.1016/j.scitotenv.2018.02.276>
- Qaid, A., & Ossen, D. R. (2015). Effect of asymmetrical street aspect ratios on microclimates in hot, humid regions. *International Journal of Biometeorology* 59: 657-677. <https://doi.org/10.1007/s00484-014-0878-5>
- Qaid, A., & Ossen, D. R. (2015). Effect of asymmetrical street aspect ratios on microclimates in hot, humid regions. *International Journal of Biometeorology* 59(6): 657-677. <https://doi.org/10.1007/s00484-014-0878-5>
- Qin, Y., Liang, J., Tan, K., & Li, F. (2016). A side by side comparison of the cooling effect of building blocks with retro-reflective and diffuse-reflective walls. *Solar Energy* 133: 172-179. <https://doi.org/10.1016/j.solener.2016.03.067>
- Ragheb, A. A., El-Darwish, I. I., & Ahmed, S. (2016). Microclimate and human comfort considerations in planning a historic urban quarter. *International Journal of Sustainable Built Environment* 5(1): 156-167. <https://doi.org/10.1016/j.ijbsbe.2016.03.003>
- Rahman, M. A., Franceschi, E., Pattnaik, N., Moser-Reischl, A., Hartmann, C., Paeth, H., Pretzsch, H., Rötzer, T., & Pauleit, S. (2022). Spatial and temporal changes of outdoor thermal stress: influence of urban land cover types. *Scientific Reports* 12(1): 1-13. <https://doi.org/10.1038/s41598-021-04669-8>
- Rajagopalan, P., Andamon, M. M., & Paolini, R. (2020). Investigating thermal comfort and energy impact through microclimate monitoring-a citizen science approach. *Energy and Buildings* 229: 110526. <https://doi.org/10.1016/j.enbuild.2020.110526>
- Rajan, E. H. S., & Amirtham, L. R. (2021). Impact of building regulations on the perceived outdoor thermal comfort in the mixed-use neighbourhood of Chennai. *Frontiers of Architectural Research* 10(1): 148-163. <https://doi.org/10.1016/j.foar.2020.09.002>
- Ramyar, R., Zarghami, E., & Bryant, M. (2019). Spatio-temporal planning of urban neighborhoods in the context of global climate change: Lessons for urban form design in Tehran, Iran. *Sustainable Cities and Society* 51: 101554. <https://doi.org/10.1016/j.scs.2019.101554>
- Reduction, I. S. f. D. (2004). Living with risk: A global review of disaster reduction initiatives.
- Rezaei Rad, H., Rafieian, M., & Sozer, H. (2019). Evaluating the effects of increasing of building height on land surface temperature. *Journal of Urban Management and Energy Sustainability* 1(1): 52-57. <https://doi.org/10.22034/ijumes.2019.01.01.002>

Riahi, K., Van Vuuren, D. P., Kriegler, E., Edmonds, J., O'Neill, B. C., Fujimori, S., Bauer, N., Calvin, K., Dellink, R., & Fricko, O. (2017). The Shared Socioeconomic Pathways and their energy, land use, and greenhouse gas emissions implications: An overview. *Global Environmental Change* 42: 153-168. <https://doi.org/10.1016/j.gloenvcha.2016.05.009>

Richards, P., Mallinson, G., McMillan, D., & Li, Y. (2002). Pedestrian level wind speeds in downtown Auckland. *Wind & Structures* 5(2): 151-164.

Rodríguez-Algeciras, J., Tablada, A., & Matzarakis, A. (2018). Effect of asymmetrical street canyons on pedestrian thermal comfort in warm-humid climate of Cuba. *Theoretical and Applied Climatology* 133: 663-679. <https://doi.org/10.1007/s00704-017-2204-8>

Roos, P., Siddiqui, P., Herron, M., Jones, D., & Duncan, E. (2020). Climate Change and Heatwave Project: Identification of high-risk areas across the City of Greater Geelong. *Live+Smart Research Laboratory, Deakin University*. <https://hdl.handle.net/10536/DRO/DU:30145724>

Rossi, F., Cardinali, M., Gambelli, A. M., Filippini, M., Castellani, M., B., & Nicolini, A. (2020). Outdoor thermal comfort improvements due to innovative solar awning solutions: An experimental campaign. *Energy and Buildings* 225. <https://doi.org/10.1016/j.enbuild.2020.110341>

Rossi, F., Cardinali, M., Gambelli, A. M., Filippini, M., Castellani, B., & Nicolini, A. (2020). Outdoor thermal comfort improvements due to innovative solar awning solutions: An experimental campaign. *Energy and Buildings* 225: 110341. <https://doi.org/10.1016/j.enbuild.2020.110341>

Rossi, F., Pisello, A. L., Nicolini, A., Filippini, M., & Palombo, M. (2014). Analysis of retro-reflective surfaces for urban heat island mitigation: A new analytical model. *Applied Energy* 114: 621-631. <https://doi.org/10.1016/j.apenergy.2013.10.038>

Rosso, F., Golasi, I., Castaldo, V. L., Piselli, C., Pisello, A. L., Salata, F., Ferrero, M., Cotana, F., & de Lieto Vollaro, A. (2018). On the impact of innovative materials on outdoor thermal comfort of pedestrians in historical urban canyons. *Renewable Energy* 118: 825-839. <https://doi.org/10.1016/j.renene.2017.11.074>

Rosso, F., Pioppi, B., & Pisello, A. L. (2022). Pocket parks for human-centered urban climate change resilience: Microclimate field tests and multi-domain comfort analysis through portable sensing techniques and citizens' science. *Energy and Buildings* 260: 111918. <https://doi.org/10.1016/j.enbuild.2022.111918>

Roth, M., & Lim, V. H. (2017). Evaluation of canopy-layer air and mean radiant temperature simulations by a microclimate model over a tropical residential neighbourhood. *Building and Environment* 112: 177-189. <https://doi.org/10.1016/j.buildenv.2016.11.026>

Rui, L., Buccolieri, R., Gao, Z., Gatto, E., & Ding, W. (2019). Study of the effect of green quantity and structure on thermal comfort and air quality in an urban-like residential district by ENVI-met modelling. *Building Simulation*(12): 183–194. <https://doi.org/10.1007/s12273-018-0498-9>

Rummukainen, M. (2012). Changes in climate and weather extremes in the 21st century. Wiley Interdisciplinary Reviews: *Climate Change* 3(2): 115-129. <https://doi.org/10.1002/wcc.160>

Russell, R., Guerry, A. D., Balvanera, P., Gould, R. K., Basurto, X., Chan, K. M., Klain, S., Levine, J., & Tam, J. (2013). Humans and nature: how knowing and experiencing nature affect well-being. *Annual Review of Environment and Resources* 38: 473-502. <https://doi.org/10.1146/annurev-environ-012312-110838>

Sadeghi, M., Chaston, T., Hanigan, I., Dear, R. de, Santamouris, M., Jalaludin, B., & Morgan, G. G. (2022). The health benefits of greening strategies to cool urban environments—A heat health impact method. *Building and Environment* 207: 108546. <https://doi.org/10.1016/j.buildenv.2021.108546>

Saelens, B. E., Sallis, J. F., & Frank, L. D. (2003). Environmental correlates of walking and cycling: findings from the transportation, urban design, and planning literatures. *Annals of Behavioral Medicine* 25(2): 80-91. https://doi.org/10.1207/S15324796ABM2502_03

Salata, F., Golasi, I., de Lieto Vollaro, A., & de Lieto Vollaro, R. (2015). How high albedo and traditional buildings' materials and vegetation affect the quality of urban microclimate. A case study. *Energy and Buildings* 99: 32-49. <https://doi.org/10.1016/j.enbuild.2015.04.010>

Salata, F., Golasi, I., de Lieto Vollaro, R., & de Lieto Vollaro, A. (2016). Urban microclimate and outdoor thermal comfort. A proper procedure to fit ENVI-met simulation outputs to experimental data. *Sustainable Cities and Society* 26: 318-343. <https://doi.org/10.1016/j.scs.2016.07.005>

Salata, F., Golasi, I., Petitti, D., de Lieto Vollaro, E., Coppi, M., & de Lieto Vollaro, A. (2017). Relating microclimate, human thermal comfort and health during heat waves: An analysis of heat island mitigation strategies through a case study in an urban outdoor environment. *Sustainable Cities and Society* 30: 79-96. <https://doi.org/10.1016/j.scs.2017.01.006>

Salimi Turkamani, H. (2021). From Kyoto to Paris: Problematic route of state responsibility for climate change. *Environmental Law Review* 23(4): 321-335. <https://doi.org/10.1177/14614529211058849>

- Salvati, A., & Kolokotroni, M. (2020, April 16-19). *Impact of urban albedo on microclimate and thermal comfort over a heat wave event in London*. The Windsor Conference: 566-578, Windsor, Canada. <https://bura.brunel.ac.uk/handle/2438/22214>
- Salvati, A., Kolokotroni, M., Kotopouleas, A., Watkins, R., Giridharan, R., & Nikolopoulou, M. (2022). Impact of reflective materials on urban canyon albedo, outdoor and indoor microclimates. *Building and Environment* 207: 108459. <https://doi.org/10.1016/j.buildenv.2021.108459>
- Santamouris, M. (2020). Recent progress on urban overheating and heat island research. Integrated assessment of the energy, environmental, vulnerability and health impact. Synergies with the global climate change. *Energy and Buildings* 207: 109482. <https://doi.org/10.1016/j.enbuild.2019.109482>
- Santamouris, M., Ding, L., Fiorito, F., Oldfield, P., Osmond, P., Paolini, R., Prasad, D., & Synnefa, A. (2017). Passive and active cooling for the outdoor built environment—Analysis and assessment of the cooling potential of mitigation technologies using performance data from 220 large scale projects. *Solar Energy* 154: 14-33. <https://doi.org/10.1016/j.solener.2016.12.006>
- Santamouris, M., Haddad, S., Saliari, M., Vasilakopoulou, K., Synnefa, A., Paolini, R., Ulpiani, G., Garshasbi, S., & Fiorito, F. (2018). On the energy impact of urban heat island in Sydney: Climate and energy potential of mitigation technologies. *Energy and Buildings* 166: 154-164. <https://doi.org/10.1016/j.enbuild.2018.02.007>
- Santos Nouri, A., Costa, J. P., Santamouris, M., & Matzarakis, A. (2018). Approaches to outdoor thermal comfort thresholds through public space design: A review. *Atmosphere* 9(3): 108. <https://doi.org/10.3390/atmos9030108>
- Santos Nouri, A., Fröhlich, D., Matos Silva, M., & Matzarakis, A. (2018). The impact of Tipuana tipu species on local human thermal comfort thresholds in different urban canyon cases in Mediterranean climates: Lisbon, Portugal. *Atmosphere* 9(1): 12. <https://doi.org/10.3390/atmos9010012>
- Sanusi, R., Johnstone, D., May, P., & Livesley, S. J. (2016). Street orientation and side of the street greatly influence the microclimatic benefits street trees can provide in summer. *Journal of Environmental Quality* 45(1): 167-174. <https://doi.org/10.2134/jeq2015.01.0039>
- Sara, L. M., Jameson, S., Pfeffer, K., & Baud, I. (2016). Risk perception: The social construction of spatial knowledge around climate change-related scenarios in Lima. *Habitat International* 54: 136-149. <https://doi.org/10.1016/j.habitatint.2015.12.025>

- Schiavon, S., Hoyt, T., & Piccioli, A. (2014). Web application for thermal comfort visualization and calculation according to ASHRAE Standard 55. *Building Simulation* (7): 321–334. <https://doi.org/10.1007/s12273-013-0162-3>
- Sevtsuk, A., Ekmekci, O., Nixon, F., & Amindarbari, R. (2013, May 15-18). *Capturing Urban Intensity*. Proceedings of the 18th International Conference on Computer-Aided Architectural Design Research in Asia, 551–560.
- Shaeri, J., Aflaki, A., Yaghoubi, M., & Janalizadeh, H. (2018). Investigation of passive design strategies in a traditional urban neighborhood: A case study. *Urban Climate* 26: 31-50. <https://doi.org/10.1016/j.uclim.2018.08.003>
- Shahrestani, M., Yao, R., Luo, Z., Turkbeyler, E., & Davies, H. (2015). A field study of urban microclimates in London. *Renewable Energy* 73: 3-9. <https://doi.org/10.1016/j.renene.2014.05.061>
- Shamsuddin, S., Hassan, N. R. A., & Bilyamin, S. F. I. (2012). Walkable environment in increasing the liveability of a city. *Procedia-Social and Behavioral Sciences* 50: 167-178. <https://doi.org/10.1016/j.sbspro.2012.08.025>
- Shapiro, S. S., & Wilk, M. B. (1965). An analysis of variance test for normality (complete samples). *Biometrika* 52(3/4): 591-611. <https://doi.org/10.1093/biomet/52.3-4.591>
- Sharifi, A. (2021). Co-benefits and synergies between urban climate change mitigation and adaptation measures: A literature review. *Science of The Total Environment* 750: 141642. <https://doi.org/10.1016/j.scitotenv.2020.141642>
- Sharifi, E., & Boland, J. (2018). Limits of thermal adaptation in cities: outdoor heat-activity dynamics in Sydney, Melbourne and Adelaide. *Architectural Science Review* 61(4): 191-201. <https://doi.org/10.1080/00038628.2018.1482824>
- Sharifi, E., Larbi, M., Omrany, H., & Boland, J. (2020). Climate change adaptation and carbon emissions in green urban spaces: Case study of Adelaide. *Journal of Cleaner Production* 254: 120035. <https://doi.org/10.1016/j.jclepro.2020.120035>
- Sharifi, E., Sivam, A., & Boland, J. (2016). Resilience to heat in public space: a case study of Adelaide, South Australia. *Journal of Environmental Planning and Management* 59(10): 1833-1854. <https://doi.org/10.1080/09640568.2015.1091294>
- Sharifi, E., Sivam, A., & Boland, J. (2017). Spatial and activity preferences during heat stress conditions in Adelaide: towards increased adaptation capacity of the built environment. *Procedia Engineering* 180: 955-965. <https://doi.org/10.1016/j.proeng.2017.04.255>

- Sharmin, T., Steemers, K., & Humphreys, M. (2019). Outdoor thermal comfort and summer PET range: A field study in tropical city Dhaka. *Energy and Buildings* 198: 149-159. <https://doi.org/10.1016/j.enbuild.2019.05.064>
- Sharmin, T., Steemers, K., & Matzarakis, A. (2015). Analysis of microclimatic diversity and outdoor thermal comfort perceptions in the tropical megacity Dhaka, Bangladesh. *Building and Environment* 94: 734-750. <https://doi.org/10.1016/j.buildenv.2015.10.007>
- Sharmin, T., Steemers, K., & Matzarakis, A. (2017). Microclimatic modelling in assessing the impact of urban geometry on urban thermal environment. *Sustainable Cities and Society* 34: 293-308. <https://doi.org/10.1016/j.scs.2017.07.006>
- Shashua-Bar, L., Pearlmutter, D., & Erell, E. (2011). The influence of trees and grass on outdoor thermal comfort in a hot-arid environment. *International Journal of Climatology* 31(10): 1498-1506. <https://doi.org/10.1002/joc.2177>
- Shata, R. O., Mahmoud, A. H., & Fahmy, M. (2021). Correlating the sky view factor with the pedestrian thermal environment in a hot arid university campus plaza. *Sustainability* 13(2): 468. <https://doi.org/10.3390/su13020468>
- Shawesh, R., & Mohamed, M. (2021). Post-occupancy evaluation of outdoor thermal comfort in hot arid zone. *International Journal of Low-Carbon Technologies* 16(1): 50-60. <https://doi.org/10.1093/ijlct/ctaa035>
- Shen, H., Tao, S., Chen, Y., Ciais, P., Güneralp, B., Ru, M., Zhong, Q., Yun, X., Zhu, X., & Huang, T. (2017). Urbanization-induced population migration has reduced ambient PM2.5 concentrations in China. *Science Advances* 3(7): e1700300.
- Sheweka, S., & Magdy, A. N. (2011). The living walls as an approach for a healthy urban environment. *Energy Procedia* 6: 592-599. <https://doi.org/10.1016/j.egypro.2011.05.068>
- Shinzato, P., Simon, H., Silva Duarte, D. H., & Bruse, M. (2019). Calibration process and parametrization of tropical plants using ENVI-met V4—Sao Paulo case study. *Architectural Science Review* 62(2): 112-125. <https://doi.org/10.1080/00038628.2018.1563522>
- Shooshtarian, S., Iyer-Raniga, U., Andamon, M., & Ridley, I. (2015, December 2-4). *Thermal perceptions and microclimates of educational urban precincts in two different seasons in Melbourne*. Proceedings of the 49th International Conference of the Architectural Science Association, Melbourne, Australia.
- Shooshtarian, S., Lam, C. K. C., & Kenawy, I. (2020). Outdoor thermal comfort assessment: A review on thermal comfort research in Australia. *Building and Environment* 177: 106917. <https://doi.org/10.1016/j.buildenv.2020.106917>

- Shooshtarian, S., & Rajagopalan, P. (2018). Daytime thermal performance of different urban surfaces: A case study in educational institution precinct of Melbourne. *Architectural Science Review* 61(1-2): 29-47. <https://doi.org/10.1080/00038628.2018.1432475>
- Shooshtarian, S., & Rajagopalan, P. (2019). Perception of wind in open spaces. *Climate* 7(9): 106. <https://doi.org/10.3390/cli7090106>
- Shooshtarian, S., & Ridley, I. (2016). Determination of acceptable thermal range in outdoor built environments by various methods. *Smart and Sustainable Built Environment* 5(4): 352-371.
- Shooshtarian, S., & Ridley, I. (2016). The effect of individual and social environments on the users thermal perceptions of educational urban precincts. *Sustainable Cities and Society* 26: 119-133. <https://doi.org/10.1016/j.scs.2016.06.005>
- Shooshtarian, S., & Ridley, I. (2017). The effect of physical and psychological environments on the users thermal perceptions of educational urban precincts. *Building and Environment* 115: 182-198. <https://doi.org/10.1016/j.buildenv.2016.12.022>
- Short, A. D. (2022). Australian beach systems: Are they at risk to climate change? *Ocean & Coastal Management* 224: 106180. <https://doi.org/10.1016/j.ocecoaman.2022.106180>
- Shu, C., Wang, L. L., & Mortezaazadeh, M. (2020). Dimensional analysis of Reynolds independence and regional critical Reynolds numbers for urban aerodynamics. *Journal of Wind Engineering and Industrial Aerodynamics* 203: 104232. <https://doi.org/10.1016/j.jweia.2020.104232>
- Sidawi, B., Hamza, N., & Khalid Setaih, P. C. (2014). CFD modeling as a tool for assessing outdoor thermal comfort conditions in urban settings in hot arid climates. *Journal of Information Technology in Construction (ITCon)*: 248-269. <http://www.itcon.org/2014/14>
- Simon, H., Lindén, J., Hoffmann, D., Braun, P., Bruse, M., & Esper, J. (2018). Modeling transpiration and leaf temperature of urban trees—a case study evaluating the microclimate model ENVI-met against measurement data. *Landscape and Urban Planning* 174: 33-40. <https://doi.org/10.1016/j.landurbplan.2018.03.003>
- Singh, E., & Shindikar, M. (2023). A Comprehensive Review on Climate Change and Its Effects. *International Journal of Environment and Climate Change* 13(11): 924-931. <https://doi.org/10.9734/ijecc/2023/v13i113240>
- Singh, N., Singh, S., & Mall, R. (2020). Urban ecology and human health: implications of urban heat island, air pollution and climate change nexus. *Urban Ecology, Elsevier*: 317-334. <https://doi.org/10.1016/B978-0-12-820730-7.00017-3>

- Skelhorn, C., Lindley, S., & Levermore, G. (2014). The impact of vegetation types on air and surface temperatures in a temperate city: A fine scale assessment in Manchester, UK. *Landscape and Urban Planning* 121: 129-140. <https://doi.org/10.1016/j.landurbplan.2013.09.012>
- Skelhorn, C. P., Levermore, G., & Lindley, S. J. (2016). Impacts on cooling energy consumption due to the UHI and vegetation changes in Manchester, UK. *Energy and Buildings* 122: 150-159. <https://doi.org/10.1016/j.enbuild.2016.01.035>
- Soares, R., Corvacho, H., & Alves, F. (2021). Summer Thermal Conditions in Outdoor Public Spaces: A Case Study in a Mediterranean Climate. *Sustainability* 13(10): 5348. <https://doi.org/10.3390/su13105348>
- Sodoudi, S., Zhang, H., Chi, X., Müller, F., & Li, H. (2018). The influence of spatial configuration of green areas on microclimate and thermal comfort. *Urban Forestry & Urban Greening* 34: 85-96. <https://doi.org/10.1016/j.ufug.2018.06.002>
- Solera Jimenez, M. (2018). Green walls: a sustainable approach to climate change, a case study of London. *Architectural Science Review* 61(1-2): 48-57. <https://doi.org/10.1080/00038628.2017.1405789>
- Song, J., & Wang, Z.-H. (2015). Impacts of mesic and xeric urban vegetation on outdoor thermal comfort and microclimate in Phoenix, AZ. *Building and Environment* 94: 558-568. <https://doi.org/10.1016/j.buildenv.2015.10.016>
- Song, Y., Long, Y., Wu, P., & Wang, X. (2018). Are all cities with similar urban form or not? Redefining cities with ubiquitous points of interest and evaluating them with indicators at city and block levels in China. *International Journal of Geographical Information Science* 32(12): 2447-2476. <https://doi.org/10.1080/13658816.2018.1511793>
- Sosa, M. B., Correa, E. N., & Cantón, M. A. (2017). Urban grid forms as a strategy for reducing heat island effects in arid cities. *Sustainable Cities and Society* 32: 547-556. <https://doi.org/10.1016/j.scs.2017.05.003>
- Spagnolo, J., & De Dear, R. (2003). A field study of thermal comfort in outdoor and semi-outdoor environments in subtropical Sydney Australia. *Building and Environment* 38(5): 721-738. [https://doi.org/10.1016/S0360-1323\(02\)00209-3](https://doi.org/10.1016/S0360-1323(02)00209-3)
- Spronken-Smith, R., Kossmann, M., & Zavar-Reza, P. (2006). Where does all the energy go? Surface energy partitioning in suburban Christchurch under stable wintertime conditions. *Theoretical and Applied Climatology* 84(1): 137-149. <https://doi.org/10.1007/s00704-005-0151-2>

Srivanit, M., & Hokao, K. (2013). Evaluating the cooling effects of greening for improving the outdoor thermal environment at an institutional campus in the summer. *Building and Environment* 66: 158-172. <https://doi.org/10.1007/s00704-005-0151-2>

Srivanit, M., & Jareemit, D. (2020). Modeling the influences of layouts of residential townhouses and tree-planting patterns on outdoor thermal comfort in Bangkok suburb. *Journal of Building Engineering* 30: 101262. <https://doi.org/10.1016/j.jobbe.2020.101262>

Stathopoulos, T., Wu, H., & Zacharias, J. (2004). Outdoor human comfort in an urban climate. *Building and Environment* 39(3): 297-305. <https://doi.org/10.1016/j.buildenv.2003.09.001>

Steeneveld, G., Koopmans, S., van Hove, L., & Holtslag, A. (2010, August 2-6). *Urban heat island effects and human comfort in a mild Cfb climate: exploring long term observations by hobby meteorologists in The Netherlands*. 9th Symposium on the urban environment, Amer Meteorological Society, Keystone, Colorado, USA.

Stewart, I. D., & Oke, T. R. (2012). Local climate zones for urban temperature studies. *Bulletin of the American Meteorological Society* 93(12): 1879-1900. <https://doi.org/10.1175/BAMS-D-11-00019.1>

Strømman-Andersen, J., & Sattrup, P. A. (2011). The urban canyon and building energy use: Urban density versus daylight and passive solar gains. *Energy and Buildings* 43(8). <https://doi.org/10.1016/j.enbuild.2011.04.007>

Su, M. A., Ngarambe, J., Santamouris, M., & Yun, G. Y. (2021). Empirical evidence on the impact of urban overheating on building cooling and heating energy consumption. *Iscience* 24(5): 102495.

Su, Y., Zhao, Q., & Zhou, N. (2022). Improvement strategies for thermal comfort of a city block based on PET Simulation—A case study of Dalian, a cold-region city in China. *Energy and Buildings* 261: 111557. <https://doi.org/10.1016/j.enbuild.2021.111557>

Summers, J., Cheng, H.-Y., Lin, H.-H., Barnard, L. T., Kvalsvig, A., Wilson, N., & Baker, M. G. (2020). Potential lessons from the Taiwan and New Zealand health responses to the COVID-19 pandemic. *The Lancet Regional Health—Western Pacific* 4. <https://doi.org/10.1016/j.lanwpc.2020.100044>

Sun, S., Xu, X., Lao, Z., Liu, W., Li, Z., García, E. H., He, L., & Zhu, J. (2017). Evaluating the impact of urban green space and landscape design parameters on thermal comfort in hot summer by numerical simulation. *Building and Environment* 123: 277-288. <https://doi.org/10.1016/j.buildenv.2017.07.010>

Swan, W. (2010). *Australia to 2050: future challenges*, Commonwealth of Australia Canberra. Canberra, Australian Capital Territory, Department of the Treasury.

- Synnefa, A., Karlessi, T., Gaitani, N., Santamouris, M., Assimakopoulos, D., & Papakatsikas, C. (2011). Experimental testing of cool colored thin layer asphalt and estimation of its potential to improve the urban microclimate. *Building and Environment* 46(1): 38-44. <https://doi.org/10.1016/j.buildenv.2010.06.014>
- Tablada, A., De Troyer, F., Blocken, B., Carmeliet, J., & Verschure, H. (2009). On natural ventilation and thermal comfort in compact urban environments—the Old Havana case. *Building and Environment* 44(9): 1943-1958. <https://doi.org/10.1016/j.buildenv.2009.01.008>
- Taher, H., Elsharkawy, H., & Newport, D. (2019, August 29). *The influence of urban green systems on the urban heat island effect in London*. IOP Conference Series: Earth and Environmental Science, IOP Publishing. <https://doi.org/10.1088/1755-1315/329/1/012046>
- Tahir, F., A. Baloch, A., & Al-Ghamdi, S. G. (2022). Impact of climate change on solar monofacial and bifacial Photovoltaics (PV) potential in Qatar. *Energy Reports* 8: 518-522.
- Taleghani, M. (2018). The impact of increasing urban surface albedo on outdoor summer thermal comfort within a university campus. *Urban Climate* 24: 175-184. <https://doi.org/10.1016/j.uclim.2018.03.001>
- Taleghani, M. (2018). Outdoor thermal comfort by different heat mitigation strategies-A review. *Renewable and Sustainable Energy Reviews* 81: 2011-2018. <https://doi.org/10.1016/j.rser.2017.06.010>
- Taleghani, M., & Berardi, U. (2018). The effect of pavement characteristics on pedestrians' thermal comfort in Toronto. *Urban Climate* 24: 449-459. <https://doi.org/10.1016/j.uclim.2017.05.007>
- Taleghani, M., Kleerekoper, L., Tenpierik, M., & Van Den Dobbelen, A. (2015). Outdoor thermal comfort within five different urban forms in the Netherlands. *Building and Environment* 83: 65-78. <https://doi.org/10.1016/j.buildenv.2014.03.014>
- Taleghani, M., Sailor, D., & Ban-Weiss, G. A. (2016). Micrometeorological simulations to predict the impacts of heat mitigation strategies on pedestrian thermal comfort in a Los Angeles neighborhood. *Environmental Research Letters* 11(2): 024003. <https://doi.org/10.1088/1748-9326/11/2/024003>
- Tan, J., Zheng, Y., Tang, X., Guo, C., Li, L., Song, G., Zhen, X., Yuan, D., Kalkstein, A. J., & Li, F. (2010). The urban heat island and its impact on heat waves and human health in Shanghai. *International Journal of Biometeorology* 54(1): 75-84. <https://doi.org/10.1007/s00484-009-0256-x>

- Tan, Z., Chung, S. C., Roberts, A. C., & Lau, K. K.-L. (2019). Design for climate resilience: influence of environmental conditions on thermal sensation in subtropical high-density cities. *Architectural Science Review* 62(1): 3-13. <https://doi.org/10.1080/00038628.2018.1495612>
- Tan, Z., Lau, K. K.-L., & Ng, E. (2016). Urban tree design approaches for mitigating daytime urban heat island effects in a high-density urban environment. *Energy and Buildings* 114: 265-274. <https://doi.org/10.1016/j.enbuild.2015.06.031>
- Tan, Z., Lau, K. K.-L., & Ng, E. (2017). Planning strategies for roadside tree planting and outdoor comfort enhancement in subtropical high-density urban areas. *Building and Environment* 120: 93-109. <https://doi.org/10.1016/j.buildenv.2017.05.017>
- Tapper, N., Tyson, P., Owens, I., & Hastie, W. (1981). Modeling the winter urban heat island over Christchurch, New Zealand. *Journal of Applied Meteorology and Climatology* 20(4): 365-376. [https://doi.org/10.1175/1520-0450\(1981\)020%3C0365:VKECOH%3E2.0.CO;2](https://doi.org/10.1175/1520-0450(1981)020%3C0365:VKECOH%3E2.0.CO;2)
- Taubenböck, H., Wegmann, M., Roth, A., Mehl, H., & Dech, S. (2009). Urbanization in India—Spatiotemporal analysis using remote sensing data. *Computers, Environment and Urban Systems* 33(3): 179-188. <https://doi.org/10.1016/j.compenvurbsys.2008.09.003>
- Tavares, S. G., Swaffield, S. R., & Stewart, E. J. (2019). A case-based methodology for investigating urban comfort through interpretive research and microclimate analysis in post-earthquake Christchurch, New Zealand. *Environment and Planning B: Urban Analytics and City Science* 46(4): 731-750. <https://doi.org/10.1177/2399808317725318>
- Thorsson, S., Lindqvist, M., & Lindqvist, S. (2004). Thermal bioclimatic conditions and patterns of behaviour in an urban park in Göteborg, Sweden. *International Journal of Biometeorology* 48(3): 149-156. <https://doi.org/10.1007/s00484-003-0189-8>
- Todorović, M. S. (2012). BPS, energy efficiency and renewable energy sources for buildings greening and zero energy cities planning: Harmony and ethics of sustainability. *Energy and Buildings* 48: 180-189. <https://doi.org/10.1016/j.enbuild.2012.01.027>
- Toparlar, Y., Blocken, B., Maiheu, B. v., & Van Heijst, G. (2018). The effect of an urban park on the microclimate in its vicinity: a case study for Antwerp, Belgium. *International Journal of Climatology* 38: e303-e322. <https://doi.org/10.1002/joc.5371>
- Tornay, N., Schoetter, R., Bonhomme, M., Faraut, S., & Masson, V. (2017). GENIUS: A methodology to define a detailed description of buildings for urban climate and building energy consumption simulations. *Urban Climate* 20: 75-93. <https://doi.org/10.1016/j.uclim.2017.03.002>
- Tseliou, A., Tsiros, I. X., Nikolopoulou, M., & Papadopoulos, G. (2016). Outdoor thermal sensation in a Mediterranean climate (Athens): The effect of selected microclimatic parameters.

<https://doi.org/10.1080/00038628.2015.1028022>

Tsitoura, M., Michailidou, M., & Tsoutsos, T. (2016). Achieving sustainability through the management of microclimate parameters in Mediterranean urban environments during summer. *Sustainable Cities and Society* 26: 48-64. <https://doi.org/10.1016/j.scs.2016.05.006>

Tsoka, S., Theodosiou, T., Tsikaloudaki, K., & Flourentzou, F. (2018). Modeling the performance of cool pavements and the effect of their aging on outdoor surface and air temperatures. *Sustainable Cities and Society* 42: 276-288.

<https://doi.org/10.1016/j.scs.2018.07.016>

Tsoka, S., Tsikaloudaki, A., & Theodosiou, T. (2018). Analyzing the ENVI-met microclimate model's performance and assessing cool materials and urban vegetation applications—A review. *Sustainable Cities and Society* 43: 55-76. <https://doi.org/10.1016/j.scs.2018.08.009>

Tsoka, S., Tsikaloudaki, K., & Theodosiou, T. (2017). Urban space's morphology and microclimatic analysis: A study for a typical urban district in the Mediterranean city of Thessaloniki, Greece. *Energy and Buildings* 156: 96-108.

<https://doi.org/10.1016/j.enbuild.2017.09.066>

Tsoka, S., Tsikaloudaki, K., Theodosiou, T., & Bikas, D. (2020). Urban Warming and Cities' Microclimates: Investigation Methods and Mitigation Strategies—A Review. *Energies* 13(6): 1414. <https://doi.org/10.3390/en13061414>

Tuller, S. (1980). Effects of a moderate sized city on human thermal bioclimate during clear winter nights. *International Journal of Biometeorology* 24: 97-106. <https://doi.org/10.1007/BF02245549>

Tuller, S. (1980). Effects of a moderate sized city on human thermal bioclimate during clear winter nights. *International Journal of Biometeorology* 24(1): 97-106. <https://doi.org/10.1007/BF02245549>

Tumini, I., Higuera García, E., & Baereswyl Rada, S. (2016). Urban microclimate and thermal comfort modelling: strategies for urban renovation. *International Journal of Sustainable Building Technology and Urban Development* 7(1): 22-37.

<https://doi.org/10.1080/2093761X.2016.1152204>

Ulpiani, G. (2021). On the linkage between urban heat island and urban pollution island: Three-decade literature review towards a conceptual framework. *Science of the Total Environment* 751: 141727. <https://doi.org/10.1016/j.scitotenv.2020.141727>

- Varo, J. J., Martínez-González, M. A., de Irala-Estévez, J., Kearney, J., Gibney, M., & Martínez, J. A. (2003). Distribution and determinants of sedentary lifestyles in the European Union. *International Journal of Epidemiology* 32(1): 138-146. <https://doi.org/10.1093/ije/dyg116>
- Vasilikou, C., & Nikolopoulou, M. (2020). Outdoor thermal comfort for pedestrians in movement: thermal walks in complex urban morphology. *International Journal of Biometeorology* 64: 277-291. <https://doi.org/10.1007/s00484-019-01782-2>
- Vásquez-Álvarez, P. E., Flores-Vázquez, C., Cobos-Torres, J.-C., & Cobos-Mora, S. L. (2022). Urban Heat Island Mitigation through Planned Simulation. *Sustainability* 14(14): 8612. <https://doi.org/10.3390/su14148612>
- Venhari, A. A., Tenpierik, M., & Taleghani, M. (2019). The role of sky view factor and urban street greenery in human thermal comfort and heat stress in a desert climate. *Journal of Arid Environments* 166: 68-76. <https://doi.org/10.1016/j.jaridenv.2019.04.009>
- Vlahov, D., Freudenberg, N., Proietti, F., Ompad, D., Quinn, A., Nandi, V., & Galea, S. (2007). "Urban as a determinant of health. *Journal of Urban Health* 84(1): 16-26. <https://doi.org/10.1007/s11524-007-9169-3>
- Voogt, J. A., & Oke, T. R. (2003). Thermal remote sensing of urban climates. *Remote Sensing of Environment* 86(3): 370-384. [https://doi.org/10.1016/S0034-4257\(03\)00079-8](https://doi.org/10.1016/S0034-4257(03)00079-8)
- Wahba, S., Kamil, B., Nassar, K., & Abdelsalam, A. (2019). Green envelop impact on reducing air temperature and enhancing outdoor thermal comfort in arid climates. *Civil Engineering Journal* 5(5): 1124-1135.
- Wai, K.-M., Xiao, L., & Tan, T. Z. (2021). Improvement of the outdoor thermal comfort by water spraying in a high-density urban environment under the influence of a future (2050) climate. *Sustainability* 13(14): 7811. <https://doi.org/10.3390/su13147811>
- Wai, K.-M., Yuan, C., Lai, A., & Peter, K. (2020). Relationship between pedestrian-level outdoor thermal comfort and building morphology in a high-density city. *Science of the Total Environment* 708: 134516. <https://doi.org/10.1016/j.scitotenv.2019.134516>
- Walton, D., Dravitzki, V., & Donn, M. (2007). The relative influence of wind, sunlight and temperature on user comfort in urban outdoor spaces. *Building and Environment* 42(9): 3166-3175. <https://doi.org/10.1016/j.buildenv.2006.08.004>
- Wan, G., & Wang, C. (2014). Unprecedented urbanisation in Asia and its impacts on the environment. *Australian Economic Review* 47(3): 378-385. <https://doi.org/10.1111/1467-8462.12076>

- Wang, J., Guo, W., Wang, C., Yao, Y., Kou, K., Xian, D., & Zhang, Y. (2021). Tree crown geometry and its performances on human thermal comfort adjustment. *Journal of Urban Management* 10(1): 16-26. <https://doi.org/10.1016/j.jum.2021.02.001>
- Wang, K., Fang, X., Ma, Y., Xue, S., & Yin, S. (2022). Assessing Effects of Urban Greenery on the Regulation Mechanism of Microclimate and Outdoor Thermal Comfort during Winter in China's Cold Region. *Land* 11(9): 1442. <https://doi.org/10.3390/land11091442>
- Wang, R., Ren, C., Xu, Y., Lau, K. K.-L., & Shi, Y. (2018). Mapping the local climate zones of urban areas by GIS-based and WUDAPT methods: A case study of Hong Kong. *Urban Climate* 24: 567-576. <https://doi.org/10.1016/j.uclim.2017.10.001>
- Wang, W., Xu, Y., Ng, E., & Raasch, S. (2018). Evaluation of satellite-derived building height extraction by CFD simulations: a case study of neighborhood-scale ventilation in Hong Kong. *Landscape and Urban Planning* 170: 90-102. <https://doi.org/10.1016/j.landurbplan.2017.11.008>
- Wang, Y., Berardi, U., & Akbari, H. (2016). Comparing the effects of urban heat island mitigation strategies for Toronto, Canada. *Energy and Buildings* 114: 2-19. <https://doi.org/10.1016/j.enbuild.2015.06.046>
- Wang, Y., Zhou, D., Wang, Y., Fang, Y., Yuan, Y., & Lv, L. (2019). Comparative study of urban residential design and microclimate characteristics based on ENVI-met simulation. *Indoor and Built Environment* 28(9): 1200-1216. <https://doi.org/10.1177/1420326X19860884>
- Weng, Q., Lu, D., & Schubring, J. (2004). Estimation of land surface temperature–vegetation abundance relationship for urban heat island studies. *Remote Sensing of Environment* 89(4): 467-483. <https://doi.org/10.1016/j.rse.2003.11.005>
- White, C. J., McInnes, K. L., Cechet, R. P., Corney, S. P., Grose, M. R., Holz, G. K., Katzfey, J. J., & Bindoff, N. L. (2013). On regional dynamical downscaling for the assessment and projection of temperature and precipitation extremes across Tasmania, Australia. *Climate Dynamics* 41: 3145-3165. <https://doi.org/10.1007/s00382-013-1718-8>
- Wilkinson, E. (2016). Climate change, migration and the 2030 Agenda for Sustainable Development. *Federal Department of Foreign Affairs FDFA, Swiss Agency for Development and Cooperation SDC*.
- Wong, N. H., Chen, Y., Ong, C. L., & Sia, A. (2003). Investigation of thermal benefits of rooftop garden in the tropical environment. *Building and Environment* 38(2): 261-270. [https://doi.org/10.1016/S0360-1323\(02\)00066-5](https://doi.org/10.1016/S0360-1323(02)00066-5)

- Wong, N. H., Jusuf, S. K., & Tan, C. L. (2011). Integrated urban microclimate assessment method as a sustainable urban development and urban design tool. *Landscape and Urban Planning* 100(4): 386-389. <https://doi.org/10.1016/j.landurbplan.2011.02.012>
- Wu, Z., Kong, F., Wang, Y., Sun, R., & Chen, L. (2016). The impact of greenspace on thermal comfort in a residential quarter of Beijing, China. *International Journal of Environmental Research and Public Health* 13(12): 1217. <https://doi.org/10.3390/ijerph13121217>
- Wuni, I. Y., Shen, G. Q., & Osei-Kyei, R. (2019). Scientometric review of global research trends on green buildings in construction journals from 1992 to 2018. *Energy and Buildings* 190: 69-85. <https://doi.org/10.1016/j.enbuild.2019.02.010>
- Xi, T., Li, Q., Mochida, A., & Meng, Q. (2012). Study on the outdoor thermal environment and thermal comfort around campus clusters in subtropical urban areas. *Building and Environment* 52: 162-170. <https://doi.org/10.1016/j.buildenv.2011.11.006>
- Xie, X., Sahin, O., Luo, Z., & Yao, R. (2020). Impact of neighbourhood-scale climate characteristics on building heating demand and night ventilation cooling potential. *Renewable Energy* 150: 943-956. <https://doi.org/10.1016/j.renene.2019.11.148>
- Xiong, Y., Zhang, J., Xu, X., Yan, Y., Sun, S., & Liu, S. (2020). Strategies for improving the microclimate and thermal comfort of a classical Chinese garden in the hot-summer and cold-winter zone. *Energy and Buildings* 215: 109914. <https://doi.org/10.1016/j.enbuild.2020.109914>
- Xu, X., Yin, C., Wang, W., Xu, N., Hong, T., & Li, Q. (2019). Revealing urban morphology and outdoor comfort through genetic algorithm-driven urban block design in dry and hot regions of China. *Sustainability* 11(13): 3683. <https://doi.org/10.3390/su11133683>
- Yagüe, C., Zurita, E., & Martinez, A. (1991). Statistical analysis of the Madrid urban heat island. *Atmospheric Environment. Part B. Urban Atmosphere* 25(3): 327-332. [https://doi.org/10.1016/0957-1272\(91\)90004-X](https://doi.org/10.1016/0957-1272(91)90004-X)
- Yahia, M. W., Johansson, E., Thorsson, S., Lindberg, F., & Rasmussen, M. I. (2018). Effect of urban design on microclimate and thermal comfort outdoors in warm-humid Dar es Salaam, Tanzania. *International Journal of Biometeorology* 62(3): 373-385. <https://doi.org/10.1007/s00484-017-1380-7>
- Yang, F., Qian, F., & Lau, S. S. (2013). Urban form and density as indicators for summertime outdoor ventilation potential: A case study on high-rise housing in Shanghai. *Building and Environment* 70: 122-137. <https://doi.org/10.1016/j.buildenv.2013.08.019>
- Yang, L., Zhang, L., Stettler, M. E., Sukitpaneemit, M., Xiao, D., & van Dam, K. H. (2020). Supporting an integrated transportation infrastructure and public space design: A coupled

simulation method for evaluating traffic pollution and microclimate. *Sustainable Cities and Society* 52: 101796. <https://doi.org/10.1016/j.scs.2019.101796>

Yang, S.-R., & Lin, T.-P. (2016). An integrated outdoor spaces design procedure to relieve heat stress in hot and humid regions. *Building and Environment* 99: 149-160. <https://doi.org/10.1016/j.buildenv.2016.01.001>

Yang, W., Lin, Y., & Li, C.-Q. (2018). Effects of landscape design on urban microclimate and thermal comfort in tropical climate. *Advances in Meteorology*: 13-27. <https://doi.org/10.1155/2018/2809649>

Yang, W., Wong, N. H., & Jusuf, S. K. (2013). Thermal comfort in outdoor urban spaces in Singapore. *Building and Environment* 59: 426-435. <https://doi.org/10.1016/j.buildenv.2012.09.008>

Yang, W., Wong, N. H., & Li, C. Q. (2016). Effect of street design on outdoor thermal comfort in an urban street in Singapore. *Journal of Urban Planning and Development* 142(1). [https://doi.org/10.1061/\(ASCE\)UP.1943-5444.0000285](https://doi.org/10.1061/(ASCE)UP.1943-5444.0000285)

Yannas, S. (2001). Toward more sustainable cities. *Solar Energy* 70(3): 281-294.

Yenneti, K., Ding, L., Prasad, D., Ulpiani, G., Paolini, R., Haddad, S., & Santamouris, M. (2020). Urban overheating and cooling potential in Australia: An evidence-based review. *Climate* 8(11): 126. <https://doi.org/10.3390/cli8110126>

Yigitcanlar, T., Degirmenci, K., Butler, L., & Desouza, K. C. (2022). What are the key factors affecting smart city transformation readiness? Evidence from Australian cities. *Cities* 120: 103434. <https://doi.org/10.1016/j.cities.2021.103434>

Yigitcanlar, T., & Lönnqvist, A. (2013). Benchmarking knowledge-based urban development performance: Results from the international comparison of Helsinki. *Cities* 31: 357-369. <https://doi.org/10.1016/j.cities.2012.11.005>

Yilmaz, S., Irmak, M. A., & Qaid, A. (2022). Assessing the effects of different urban landscapes and built environment patterns on thermal comfort and air pollution in Erzurum city, Turkey. *Building and Environment* 219: 109210. <https://doi.org/10.1016/j.buildenv.2022.109210>

Yilmaz, S., Külekçi, E. A., Mutlu, B. E., & Sezen, I. (2021). Analysis of winter thermal comfort conditions: street scenarios using ENVI-met model. *Environmental Science and Pollution Research* 28: 63837-63859. <https://doi.org/10.1007/s11356-020-12009-y>

Yilmaz, S., Mutlu, B. E., Aksu, A., Mutlu, E., & Qaid, A. (2021). Street design scenarios using vegetation for sustainable thermal comfort in Erzurum, Turkey. *Environmental Science and Pollution Research* 28(3): 3672-3693. <https://doi.org/10.1007/s11356-020-10555-z>

- Yin, C., Yuan, M., Lu, Y., Huang, Y., & Liu, Y. (2018). Effects of urban form on the urban heat island effect based on spatial regression model. *Science of the Total Environment* 634: 696-704. <https://doi.org/10.1016/j.scitotenv.2018.03.350>
- Yin, P., Ji, Y., Xie, J., Liu, J., Hou, Q., Zhao, S., & Jing, P. (2022). Residential wintry thermal comfort and adaptive behaviors in a cold climate in Beijing, China. *Energy and Buildings* 265: 111942. <https://doi.org/10.1016/j.enbuild.2022.111942>
- Younis, B., & Berger, S. (2004). A turbulence model for pulsatile arterial flows. *J. Biomech. Engineering* 126(5): 578-584. <https://doi.org/10.1115/1.1798032>
- Yu, B., Liu, H., Wu, J., & Lin, W.-M. (2009). Investigating impacts of urban morphology on spatio-temporal variations of solar radiation with airborne LIDAR data and a solar flux model: a case study of downtown Houston. *International Journal of Remote Sensing* 30(17): 4359-4385. <https://doi.org/10.1080/01431160802555846>
- Yu, Z., Chen, S., Wong, N. H., Ignatius, M., Deng, J., He, Y., & Hii, D. J. C. (2020). Dependence between urban morphology and outdoor air temperature: A tropical campus study using random forests algorithm. *Sustainable Cities and Society* 61: 102200. <https://doi.org/10.1016/j.scs.2020.102200>
- Yuan, C., & Chen, L. (2011). Mitigating urban heat island effects in high-density cities based on sky view factor and urban morphological understanding: A study of Hong Kong. *Architectural Science Review* 54(4): 305-315. <https://doi.org/10.1080/00038628.2011.613644>
- Yuan, C., & Ng, E. (2012). Building porosity for better urban ventilation in high-density cities—A computational parametric study. *Building and Environment* 50: 176-189. <https://doi.org/10.1016/j.buildenv.2011.10.023>
- Zafarmandi, S., Mahdavinejad, M., Norford, L., & Matzarakis, A. (2022). Analyzing thermal comfort sensations in semi-outdoor space on a university campus: on-site measurements in Tehran's hot and cold seasons. *Atmosphere* 13(7): 1034. <https://doi.org/10.3390/atmos13071034>
- Zafarmandi, S., Matzarakis, A., & Norford, L. (2023). Effects of clothing's thermal insulation on outdoor thermal comfort and thermal sensation: A case study of an outdoor space in Tehran, Iran. *Sustainable Cities and Society*: 104988.
- Zamani, Z., Heidari, S., & Hanachi, P. (2018). Reviewing the thermal and microclimatic function of courtyards. *Renewable and Sustainable Energy Reviews* 93: 580-595. <https://doi.org/10.1016/j.rser.2018.05.055>
- Zhang, L., Ma, X., Zhao, J., & Wang, M. (2019). Tourists' Thermal Experience and Health in a Commercial Pedestrianized Block: A Case Study in a Hot and Humid Region of Southern

- China. *International Journal of Environmental Research and Public Health* 16(24): 5072. <https://doi.org/10.3390/ijerph16245072>
- Zhang, L., Zhan, Q., & Lan, Y. (2018). Effects of the tree distribution and species on outdoor environment conditions in a hot summer and cold winter zone: A case study in Wuhan residential quarters. *Building and Environment* 130: 27-39. <https://doi.org/10.1016/j.buildenv.2017.12.014>
- Zhang, N., Cao, B., Wang, Z., & Zhu, Y. (2020). Effects of bedding insulation and indoor temperature on bed microclimate and thermal comfort. *Energy and Buildings* 223: 110097. <https://doi.org/10.1016/j.enbuild.2020.110097>
- Zhang, X. Q. (2016). The trends, promises and challenges of urbanisation in the world. *Habitat International* 54: 241-252. <https://doi.org/10.1016/j.habitatint.2015.11.018>
- Zhang, Y., Du, X., & Shi, Y. (2017). Effects of street canyon design on pedestrian thermal comfort in the hot-humid area of China. *International Journal of Biometeorology* 61: 1421-1432. <https://doi.org/10.1007/s00484-017-1320-6>
- Zhang, Y., Liu, J., Zheng, Z., Fang, Z., Zhang, X., Gao, Y., & Xie, Y. (2020). Analysis of thermal comfort during movement in a semi-open transition space. *Energy and Buildings* 225: 110312. <https://doi.org/10.1016/j.enbuild.2020.110312>
- Zhao, Q., Lian, Z., & Lai, D. (2021). Thermal comfort models and their developments: A review. *Energy and Built Environment* 2(1): 21-33. <https://doi.org/10.1016/j.enbenv.2020.05.007>
- Zhao, Q., Sailor, D. J., & Wentz, E. A. (2018). Impact of tree locations and arrangements on outdoor microclimates and human thermal comfort in an urban residential environment. *Urban Forestry & Urban Greening* 32: 81-91. <https://doi.org/10.1016/j.ufug.2018.03.022>
- Zhen, M., Dong, Q., Chen, P., Ding, W., Zhou, D., & Feng, W. (2021). Urban outdoor thermal comfort in western China. *Journal of Asian Architecture and Building Engineering* 20(2): 222-236. <https://doi.org/10.1080/13467581.2020.1782210>
- Zhou, X., & Chen, H. (2018). Impact of urbanization-related land use land cover changes and urban morphology changes on the urban heat island phenomenon. *Science of the Total Environment* 635: 1467-1476. <https://doi.org/10.1016/j.scitotenv.2018.04.091>
- Zinzi, M., & Agnoli, S. (2012). Cool and green roofs. An energy and comfort comparison between passive cooling and mitigation urban heat island techniques for residential buildings in the Mediterranean region. *Energy and Buildings* 55: 66-76. <https://doi.org/10.1016/j.enbuild.2011.09.024>

Zinzi, M., Carnielo, E., & Mattoni, B. (2018). On the relation between urban climate and energy performance of buildings. A three-years experience in Rome, Italy. *Applied Energy* 221: 148-160. <https://doi.org/10.1016/j.apenergy.2018.03.192>

Zölch, T., Rahman, M. A., Pfeleiderer, E., Wagner, G., & Pauleit, S. (2019). Designing public squares with green infrastructure to optimize human thermal comfort. *Building and Environment* 149: 640-654. <https://doi.org/10.1016/j.buildenv.2018.12.051>

Zou, J., Liu, J., Niu, Yu J., & Lei, C. (2021). Convective heat loss from computational thermal manikin subject to outdoor wind environments. *Building and Environment* 188: 107469. <https://doi.org/10.1016/j.buildenv.2020.107469>

Appendices

Appendix A. Distribution of survey responses collected at both locations (n=347)

Variable	Value	Frequency	Relative Frequency	Percentage
Gender	Female	174	0.5014	50.14%
	Male	173	0.4986	49.86%
Age group	16-25	138	0.3977	39.77%
	26-40	149	0.4294	42.94%
	41-60	51	0.1470	14.70%
	Above 60	9	0.0259	2.59%
Activity	Light walk	38	0.1095	10.95%
	Sitting	170	0.4899	48.99%
	Standing	139	0.4006	40.06%
Clothing	One layer	269	0.7752	77.52%
	Two layers	63	0.1816	18.16%
	More than two layers	15	0.0432	4.32%
Thermal sensation	Neutral	128	0.3689	36.89%
	Slightly cool	9	0.0259	2.59%
	Slightly warm	157	0.4524	45.24%
	Warm	53	0.1527	15.27%
Humidity sensation	Neutral	317	0.9135	91.35%
	Dry	14	0.0403	4.03%

	Humid	16	0.0461	4.61%
Wind sensation	Neutral	171	0.4928	49.28%
	Windy	176	0.5072	50.72%
Thermal preference	No change	145	0.4179	41.79%
	Cooler	194	0.5591	55.91%
	Warmer	8	0.0231	2.31%
Period living in Auckland	Below one year	67	0.1931	19.31%
	1-5 years	114	0.3285	32.85%
	Above 5 years	166	0.4784	47.84%
Indoor air conditioning before survey	Yes	123	0.3544	35.44%
	No	224	0.6456	64.56%
Type of change preferred	Changing materials	20	0.0576	5.76%
	Increasing vegetation cover	291	0.8386	83.86%
	More shaded place	30	0.0865	8.65%
	More unshaded places	6	0.0173	1.73%
Nationality	New Zealand	132	0.3804	38.04%
	Others	215	0.6196	61.96%

Appendix B. A sample questionnaire

Questionnaire survey outdoor thermal comfort analysis:	
Date:	Time:
What is your activity? <input type="checkbox"/> Sitting <input type="checkbox"/> Standing/ light work <input type="checkbox"/> Light walk <input type="checkbox"/> Moderate walking	
What is your gender? <input type="checkbox"/> Male <input type="checkbox"/> Female <input type="checkbox"/> Nonbinary	
How old are you? <input type="checkbox"/> Between 16 and 25 <input type="checkbox"/> Between 25 and 40 <input type="checkbox"/> between 40 and 60 <input type="checkbox"/> above 60	
Nationality:	
What is your clothing? <input type="checkbox"/> One layer <input type="checkbox"/> Two layers <input type="checkbox"/> More than 2 layers	
How long have you been living in Auckland, New Zealand? <input type="checkbox"/> Below 1 year <input type="checkbox"/> Between 1 and 5 years <input type="checkbox"/> Above 5 years	
In the past 30 minutes, prior to survey, have you been to (or stayed in) any air condition indoor spaces: <input type="checkbox"/> Yes <input type="checkbox"/> No	
What is your thermal sensation? <input type="checkbox"/> Cold <input type="checkbox"/> Cool <input type="checkbox"/> Slightly cool <input type="checkbox"/> Nature <input type="checkbox"/> Slightly warm <input type="checkbox"/> Warm <input type="checkbox"/> Hot	
What is your thermal preference? <input type="checkbox"/> Prefer warmer <input type="checkbox"/> Prefer no change <input type="checkbox"/> Prefer cooler	
What is your humidity sensation? <input type="checkbox"/> Too dry <input type="checkbox"/> Dry <input type="checkbox"/> Nature <input type="checkbox"/> Humid <input type="checkbox"/> Too humid	
What is your wind speed sensation? <input type="checkbox"/> Little wind <input type="checkbox"/> Nature <input type="checkbox"/> Windy <input type="checkbox"/> Too much wind	
What changes do you expect for this location? <input type="checkbox"/> More shaded places <input type="checkbox"/> More unshaded places <input type="checkbox"/> Increasing vegetation cover <input type="checkbox"/> Changing materials	

Appendix C. Relationship between Thermal sensation and responses to questions

Ordinal regression was utilized to explore how the thermal sensation experienced by the participants correlates with their answers on the questionnaire. This statistical method is employed to predict the behaviour of dependent variables or outcomes that have an ordinal scale, using a collection of independent variables or predictors. The dependent variable in this case involves categories with a specific order, while the independent variables can encompass both categorical and continuous factors (Armstrong and Sloan 1989). The ordinal data was analysed with cumulative link models using the R package called ordinal. When using ordinal

regression to analyse the relationship between an ordinal outcome and categorical predictors, the model estimates how the odds of being in a particular category of the ordinal variable change based on the levels of the categorical predictors. It does this by estimating separate cumulative probabilities or odds for each category of the ordinal outcome, based on the different levels of the categorical predictors.

We examined the thermal sensation responses for all 347 questionnaires (across both sampling locations), which range from cold, cool, slightly cool, neutral, slightly warm, warm, and very warm. The independent variables were encoded according to the responses to the questions regarding gender, age, nationality, clothing, activity, exposure to air conditioning before survey, and the length of time the respondent has lived in Auckland. In summary, this ordinal regression model suggests that age group and nationality are significant predictors of the thermal sensation.

According to the following table, the coefficient estimates for 41–60-year-olds is -1.0882 and the estimated odds ratio is approximately 0.3368. This means that the odds of being in a higher category for 41–60-year-olds are one-third (33.37%) of the odds of being in a higher category for 16–25-year-olds. This means that, on average, people in this age group (41–60-year-olds) are less likely to have a higher level of thermal Sensation vote (higher level of warmth) compared to the reference category (16–25-year-olds). Since the p-value (0.000886) is statistically significant, we have enough evidence to confidently conclude that there is a significant effect of age on thermal sensation. In other words, there is a meaningful and statistically significant difference in thermal sensation between people from different age groups.

Additionally, the coefficient estimates and the estimated odds ratio for New Zealand nationals found to be 0.5750 and 1.7777 respectively. The estimated odds ratio indicates that, on average,

people who are originally from New Zealand have approximately 1.78 times higher odds of moving up one category in their thermal sensation compared to the reference category (those from other countries). In other words, on average, people from New Zealand are more likely to have a higher level of thermal Sensation vote (higher level of warmth) compared to people from other countries. Since the p-value (0.034) is statistically significant, we have enough evidence to confidently conclude that there is a significant effect of nationality on thermal sensation.

In the following table, results of ordinal regression analysis of thermal sensation change with responses to questionnaire is displayed.

	Coefficient (B)	95% CI		P-value	OR	95% CI	
Covariates		Lower bound	Upper bound			Lower bound	Upper bound
Gender							
Male	0.0923	-0.3196	0.5048	0.6607	1.0966	0.7264	1.6567
Female	Referent	-	-	-	-	-	-
Age group							
26-40	-0.0257	-0.4653	0.4136	0.9088	0.9747	0.6279	1.5123
41-60	-1.0882	-1.7385	-0.4526	0.000886***	0.3368	0.1758	0.6360
Above 60	0.4138	-0.9305	1.7660	0.5443	1.5125	0.3944	5.8472
16-25	Referent	-	-	-	-	-	-
New Zealand national							
Yes	0.5750	0.0435	1.1108	0.034444*	1.7772	1.0444	3.0369
No	Referent	-	-	-	-	-	-
Clothing							
2 layers	-0.0994	-0.6479	0.4482	0.7220	0.9054	0.5231	1.5655
>2 layers	-0.4849	-1.5425	0.5409	0.3580	0.6158	0.2139	1.7176
1 layer	Referent	-	-	-	-	-	-
Activity							
Light walk	-0.6300	-1.3142	0.0439	0.0682.	0.5326	0.2687	1.0449
Standing	-0.1208	-0.5522	0.3094	0.5822	0.8862	0.5757	1.3626

Sitting	Referent	-	-	-	-	-	-	
<hr/>								
Indoor air conditioning before survey								
Yes		-0.2817	-0.7115	0.1456	0.1971	0.7545	0.4909	1.1568
No	Referent	-	-	-	-	-	-	
<hr/>								
Period living in Auckland								
1-5 years		0.5222	-0.0675	1.1167	0.0835	1.6857	0.9348	3.0548
Above 5 years		-0.1272	-0.7643	0.5111	0.6954	0.8806	0.4657	1.6672
Below one year	Referent	-	-	-	-	-	-	

Significant codes: 0 ‘***’ 0.001 ‘**’ 0.01 ‘*’ 0.05 ‘.’ 0.1

Appendix D. Ethics approval and documents

9 February 2023

Amirhosein Ghaffarianhoseini

Faculty of Design and Creative Technologies

Dear Amirhosein

Re Ethics Application: 22/316 Enhancing outdoor thermal comfort in thermal risk areas of Auckland University of Technology, New Zealand by examining geometry, material, and vegetation impacts.

Thank you responding to AUTEK’s conditions.

Your ethics application has been approved for three years until 9 February 2026.

Non-Standard Conditions of Approval

1. Please remove the offer of counselling and the compensation statement from the Information Sheet.

Non-standard conditions do not need to be submitted to or reviewed by AUTEK unless requested but must be completed before commencing your study.

Standard Conditions of Approval

1. The research is to be undertaken in accordance with the [Auckland University of Technology Code of Conduct for Research](#) and as approved by AUTEK.
2. All public facing documents must have the AUTEK approval number and be of a high standard of spelling and grammar. Dates on the Information Sheet(s) and Consent Form(s) must be consistent.
3. Any amendments to the project must be approved by AUTEK prior to being implemented.
4. A progress report is due annually on the anniversary of the approval date.
5. A final report is due at the expiration of the approval period, or, upon completion of project.
6. Any serious or adverse events must be reported to AUTEK, this includes unforeseen issues that might affect continued ethical acceptability of the project.
7. AUTEK grants ethical approval only. You are responsible for obtaining management permission for access from any institution or organisation at which your research is being conducted and you need to meet all ethical, legal, public health, and locality obligations or requirements for the jurisdictions in which the research is being undertaken.

The application number and title need to be referenced on all correspondence related to this project.

All forms are available online <http://www.aut.ac.nz/research/researchethics>

For any enquiries, please contact ethics@aut.ac.nz

(This is a computer-generated letter for which no signature is required)

The AUTEK Secretariat

Auckland University of Technology Ethics Committee

Participant Information Sheet

Date Information Sheet Produced:

17 01 2023

Project Title

Enhancing outdoor thermal comfort in thermal risk areas of Auckland University of Technology, New Zealand by examining geometry, material, and vegetation impacts.

What is the purpose of this research?

As the population grows and climate change is predicted, architects, and urban designers in Auckland, New Zealand, must take responsibility for improving the quality of outdoor life. In this research, we will focus on the microclimatic conditions of the urban context of Auckland. This study analyses outdoor thermal comfort in selected areas and mitigates the impact of urban contexts on future climate change in Auckland. Several methodologies were used in this study, including on-site field measurements, a structured questionnaire, and software simulations.

Research findings will be published in academic journals and presented at academic conferences.

How was I identified and why am I being invited to participate in this research?

AUT's students and staff are the participants in this study. To understand their perceptions of weather features such as air temperature, wind speed, and humidity in various outdoor areas of the AUT city campus at different times, we will ask them to fill out a paper questionnaire.

How do I agree to participate in this research?

The researcher (Saghar Hashemi) will meet with potential participants in person to talk about participating in the study at selected locations on the AUT city campus and provide information sheets. Participating in this research is voluntary (your choice), and your participation will not benefit or disadvantage you in any way. At any time, you can withdraw from the study.

What will happen in this research?

The methodology of this research includes 3 different parts:

1. Obtaining permission from AUT to place weather measurement devices on selected parts of the AUT city campus to collect meteorological data (air temperature, wind speed, wind direction, humidity, and mean radiant temperature).

2. To understand occupants' actual thermal perceptions, we will ask present students and staff to fill out paper questionnaires on selected days at defined locations. To get a better understanding of our research, we will approach them face-to-face and ask them politely to give us their time for about 10 minutes and provide them with the information sheet (a summary of our research), then invite them to fill out the paper questionnaire to better understand different people's thermal sensations in outdoor spaces at AUT.

3. For the selected areas, both meteorological data and people's perceptions of thermal conditions are required to compare with the results of software simulations. This is to determine the level of accuracy of computer simulations based on real people's perceptions and climate conditions.

What are the discomforts and risks?

Participants in this research are not at risk. This questionnaire is designed to determine participants' thermal sensations. After potential participants have expressed their willingness to participate. The researcher will explain any issues or concerns about anonymity, privacy, and non-identification of the potential participant at the time of consent. Participants may withdraw their participation at any time, at their discretion.

How will these discomforts and risks be alleviated?

AUT Student Counselling and Mental Health offers three confidential counselling sessions for adult participants in AUT research studies. Only issues arising directly from participation in the research are eligible for these sessions, not general counselling needs. To access these services, you will need to:

Visit us at WB203 City Campus, email counseling@aut.ac.nz, or call 921 9292.

If you are a research participant, please inform the receptionist of the title of my research and my name and contact information.

More information about AUT counsellors and counselling can be found at <https://www.aut.ac.nz/student-life/student-support/counselling-and-mental-health>.

What are the benefits?

I am doing this research as part of my Ph.D. thesis. Because of the projections for future population growth, and future climate change projections in Auckland, New Zealand, analysing the level of outdoor thermal comfort is vital for improving the quality of life and the level of

well-being in outdoor spaces. Auckland city council, architects, and urban planners can use the results of this research to help design a more sustainable outdoor environment to meet the thermal needs of Auckland residents and improve the quality of outdoor living.

What compensation is available for injury or negligence?

In the unlikely event of a physical injury as a result of your participation in this study, rehabilitation, and compensation for injury by accident may be available from the Accident Compensation Corporation, provided the incident details satisfy the requirements of the law and the Corporation's regulations.

How will my privacy be protected?

Participants will not be identified by name, position, designation, or role in the research, whether they share opinions or provide data, including paper questionnaires they complete. Individual opinions will not be referred to or published. All data collected will be aggregated for purposes of drawing research outcomes and will be normalized for purposes of benchmarking and comparison. Any information provided by participants will not be disclosed to any other participant or anyone else within or outside of the organization.

What are the costs of participating in this research?

It takes participants about 10 minutes to complete a paper questionnaire.

What opportunity do I have to consider this invitation?

As part of this research, questionnaires must be completed at specific times and locations, since we need to know their thermal sensations for a specific period. After introducing myself and describing our study, I give participants an information sheet and ask for around 10 minutes of their valuable time. After about 15 minutes, they will personally inform the researcher of their willingness to participate.

Will I receive feedback on the results of this research?

In addition to doing questionnaires and collecting field measurements, we will also prepare different maps as a result of our findings. The results will be published in various papers. As a result, participants will be able to see the final results after we publish the papers. These papers will be available in the AUT library, and we will put a summary of the results on the AUT news page. In addition, the information sheet includes the email address and phone number of the researcher and primary supervisor, so participants can contact them if they have any questions.

Because we won't be obtaining any personal information about participants (such as their names or email addresses), we can't share the research results with them.

What do I do if I have concerns about this research?

Any concerns regarding the nature of this project should be notified in the first instance to the Project Supervisor, Dr. Amirhosein Ghaffarianhoseini, amirhosein.ghaffarianhoseini@aut.ac.nz, 64 9 921 9999 Ext.7110

Concerns regarding the conduct of the research should be notified to the Executive Secretary of AUTEK, ethics@aut.ac.nz, (+649) 921 9999 ext 6038.

Whom do I contact for further information about this research?

Please keep this Information Sheet. You are also able to contact the research team as follows:

Researcher Contact Details:

PhD Candidate: Saghar Hashemi, Email: Saghar_hashemi@autuni.ac.nz, Address: 801, WZ building, AUT city campus

Project Supervisor Contact Details:

Dr. Amirhosein Ghaffarianhoseini, Email: amirhosein.ghaffarianhoseini@aut.ac.nz, 64 9 921 9999 Ext.7110