

OPIVA Refined

Attestation of Authorship

I hereby declare that this submission is my own work and that, to the best of my knowledge and belief, it contains no material previously published or written by another person (except where explicitly defined in the acknowledgements), nor material which to a substantial extent has been submitted for the award of any other degree or diploma of a university or other institution of higher learning.

Date:

10/06/2021

'OPIVA Refined'

A Human-centred Approach to Outpatient Intravenous Antibiotic Treatment

Written by Kate Weatherly

This exegesis was submitted to Auckland University of Technology for the degree of Master of Design, June 2021.

Acknowledgements

First and foremost, thank you, Dr Stephen Reay, for your supervision and support throughout the last year, from the initiation of this project to the countless hours of proofreading and editing.

Thank you to all my friends and family; you have supported me in numerous ways that I could never begin to list. Especially to Arin Hectors for always putting up with my endless research related ramblings and providing feedback on a multitude of ideas.

The completion of this research would not have been possible without the input and support of the Waitematā DHB's innovation team, I3. Particularly Dean Croft. Your help with participant recruitment and providing insights on the study design was invaluable. Along with I3, I am endlessly grateful to the OPIVA team. With an already packed patient care schedule, the OPIVA team was enthusiastic and more than willing to share their experiences and provide feedback on my ideas. So again, this research would not have been possible without you.

I want to thank all the participants who were involved in the research. Your passion and enthusiasm to tell your stories have given these words more meaning than I ever could alone.

Lastly, thank you to my better half, Robyn Harrison. Without the inspiration and support you have given me, I would not have been able to see this research through to its conclusion.

I am beyond lucky to have had you all as part of this journey. Thank you.

Abstract

Since its inception in America during the early 1970s, outpatient intravenous antibiotic (OPIVA) therapies have provided patients with life-saving intravenous antibiotics at home rather than in hospitals (Williams et al., 2015). OPIVA services typically involve six to eight weeks of intensive antibiotic treatment following a period of inpatient care. Beyond saving money and valuable bed spaces, these therapies have allowed patients to recover from severe infections in the comfort of their own homes. However, the existing literature around these services has essentially only considered the clinical function and outcomes of the services, with little research discussing the patient's experiences with the products that make up the treatment systems (Dodd, 2007; Zahnd et al., 1999). The existing OPIVA treatment systems comprised an elastomeric infuser, a peripherally inserted central catheter (PICC), a sterile dressing, an IV extension line, surgical tape (to manage the IV line), and a storage bag for the elastomeric infuser.

Existing literature demonstrates little understanding of how the medical devices that make up the OPIVA system could be improved. In response to this gap in the literature, this research used human-centred design (HCD) methods to explore how the medical devices that make up the Waitematā District Health Board's (Waitematā DHB) OPIVA service could be redesigned to improve the experiences of patients within the service. For many medical devices, clinical staff were the primary users. However, for OPIVA, patients must learn to manage the OPIVA treatment system themselves (or with the help of a family member or district nurse). Managing the OPIVA system involves changing the elastomeric infuser every 24 hours. In this project, primary research was conducted with previous OPIVA patients, OPIVA clinical staff and a previous patient expert user. Through the experiences and input of these participants, the research focused on improving the usability, aesthetics and ergonomics of the infuser and redesigning the storage bag to be wearable under clothing. Along with the redesign of these elements, this research proposed a new

system to replace the surgical tape used to hold the IV lines in place on the patient's arm, which could help to increase the accessibility and ease of use of the system. Participants were able to provide feedback on these concepts during expert critique sessions throughout the research, which helped inform the design process and validate the design outcomes.

By exploring how patients could be more directly involved in the medical device development process, my research used Action Research and HCD methodologies to advocate for the inclusion of patients experiences in the redesign of the products that make up the OPIVA treatment system. Many medical device development processes overlooked patients as stakeholders in the design process at the time of writing. The dominant perspectives on medical product design in the past have centred on minimising production costs while maintaining the health outcomes of patients. This development process has often left patients out of the development process (Money et al., 2011; Shah & Robinson, 2007). The findings of this research demonstrated that if patients' experiences were involved in the design process of medical devices, then the usability of those devices could be improved. This research sets a precedent for potential future design research to explore how usability for medical devices could be improved by including patients in the design process.

Glossary

Antibiotics – the name given to medicines that are used to kill bacteria and help to stop infections.

Intravenous – a term used for something which is inserted into (or takes place within) a vein or veins.

Catheter – a device that is inserted into the body to treat a disease or for a specific procedure.

Sepsis – a type of reaction to bacterial infection. Sepsis can be life-threatening and involves excess inflammation throughout the body.

Meningitis – an infection and inflammation of the membranes that surround the brain and the spinal cord.

Chemotherapy – a group of therapies used to help treat cancers by destroying cells that rapidly replicate within the body.

Occlusion – an occurrence of a blockage in a blood vessel or organ within the body.

Annular – a type of ring-shaped joint in which two parts are joined together. These often use tension to fit together.

Deep Vein Thrombosis – a condition where a blood clot forms in the deep blood vessels of the body. If this clot forms a blockage, this is known as a pulmonary embolism.

Figures

Figure 1. Weatherly, K. (2019). The Kiwi - Painless Dental Anaesthetic. Retrieved from <https://bestawards.co.nz/product/student-product/aut-art-design/the-kiwi-painless-dental-anaesthetic/>.

Figure 2. Brainstorming of the research contexts.

Figure 3. An analysis of the existing OPIVA service treatment system.

Figure 4. The OPIVA existing treatment system fitted to a patient.

Figure 5. An analysis of the Baxter branded elastomeric infuser.

Figure 6. Wolfmed. (2021). What is an Elastomeric Pump and How is it Used? Wolf Medical Supply. <https://www.wolfmed.com/blog/elastomeric-pump-uses>.

Figure 7. Dickson, C. (2017). *From Stigma to Silver Linings: Improving the Experiences of Long-Term Tracheostomy Users Through Product Design*. Auckland University of Technology.

Figure 8. Reed, H., Langley, J., Stanton, A., Heron, N., Clarke, Z., Judge, S., McCarthy, A., Squire, G., Quinn, A., Wells, O., Tindale, W., Baxter, S., Shaw, P. J., & McDermott, C. J. (2015). Head-Up; An interdisciplinary, participatory and co-design process informing the development of a novel head and neck support for people living with progressive neck muscle weakness. *Journal of Medical Engineering & Technology*, 39(7), 404–410. <https://doi-org.ezproxy.aut.ac.nz/10.3109/03091902.2015.1088092>.

Figure 9. Parbhu, N. (2015). *Valuing the voices of children: a case study of involving children in the process of medical equipment design in the hospital environment*. Auckland University of Technology.

Figure 10. Fisher & Paykel. (2021). Evora Nasal Mask. Fisher & Paykel Healthcare Limited. <https://www.fphcare.com/nz/homecare/sleep-apnea/masks/evora-nasal-mask/>

Figure 11. McGarrell, C. (2021). Sensile Medical Design Language. Craig McGarrell. <http://www.craigmcgarrell.com/sensilemedical>.

Figure 12. Couto, L. (2021). OHC - Home Breath Analysis. Behance. <https://www.behance.net/gallery/103052883/ohc-Home-Breath-Analysis>.

Figure 13. Timeline for the research.

Figure 14. Willis, J. W. (2014). *Action Research: Models, Methods, and Examples. Applied Research in Education and the Social Sciences*. Information Age Publishing.

Figure 15. Prototypes and sketches were used as research probes during expert critiques in the later stages of the research.

Figure 16. The roleplay during the research occurred with a mock OPIVA system.

Figure 17. An example of sketches used in the research.

Figure 18. An example of brainstorming used in the research.

Figure 19. An example of low fidelity prototyping used in the research.

Figure 20. All the elements of the OPIVA service prepared for an infuser change.

Figure 21. An example of the drip test on the infuser flow restrictor.

Figure 22. Christensen, A. (2011). Home PICC IV 2 : Saline Flush. Flickr. <https://www.flickr.com/photos/alchristensen/6252983164>

Figure 23. A photo of the infuser bag being kept on a bedside table.

Figure 24. An initial mood board exploring aesthetically pleasing medical products.

Figure 25. Discovery through ideation sketches.

Figure 26. Discovery through ideation, low fidelity prototyping.

Figure 27. Photos from the expert user during their time with the OPIVA service.

Figure 28. A nurse persona.

Figure 29. A patient persona.

Figure 30. Two user experience road maps.

Figure 31. Initial usability focused exploration sketches.

Figure 32. Infuser usability sketches.

Figure 33. CAD modelling of an initial infuser design.

Figure 34. Aesthetic focused exploration sketches.

Figure 35. Refined aesthetic focused infuser ideation sketches.

Figure 36. An image of the existing infuser showing the IV routing cap.

Figure 37. A CAD model of a non-medical aesthetic infuser.

Figure 38. The OPIVA system concepts presented in the second expert critique. Ease of use focused.

Figure 39. The OPIVA system concepts presented in the second expert critique. Aesthetic focused.

Figure 40. Colour palette and aesthetic mood board.

Figure 41. Infuser form refinement sketches.

Figure 42. Infuser CAD models.

Figure 43. Infuser foam model, iteration one.

Figure 44. Infuser foam model, iteration two.

Figure 45. Infuser foam model, iteration three.

Figure 46. Infuser foam model, iteration four.

Figure 47. Infuser foam model, iteration five.

Figure 48. Infuser foam model, iteration six.

Figure 49. Infuser concepts evaluation matrix.

Figure 50. CAD models based on the infuser evaluation matrix.

Figure 51. Initial rounded shell infuser CAD models.

Figure 52. The finalised rounded shell infuser CAD model.

Figure 53. The low profile infuser concept. CAD model.

Figure 54. Concepts presented during the second expert critique.

Figure 55. Infuser aesthetic mood board.

Figure 56. Initial CAD modelling based on the second expert critique.

Figure 57. Developed infuser CAD modelling.

Figure 58. Tolerance testing and 3D printing.

Figure 59. Infuser form sketches.

Figure 60. Sketches of three different infuser designs.

Figure 61. Horizontal inset infuser outlet CAD model.

Figure 62. Vertical inset infuser outlet CAD model.

Figure 63. Larger foot print (thinner) infuser CAD model.

Figure 64. Infuser concepts evaluation matrix.

Figure 65. Diagram showing possible IV outlet directions.

Figure 66. Finalised infuser CAD exploration.

Figure 67. Shroud cap infuser concept. CAD model.

Figure 68. Bottle cap style infuser concept.

Figure 69. The final form of the infuser shifted to reflect the third expert critique.

Figure 70. Exploration of the size and position of the infuser label.

Figure 71. Ideation of the size and shape of the infuser label.

Figure 72. Low fidelity prototypes to explore the positioning of the infuser label.

Figure 73. The first infuser label concept.

Figure 74. Infuser label concept two, top.

Figure 75. Infuser label concept two, bottom.

Figure 76. Infuser label concept three, top.

Figure 77. Infuser label concept three, side.

Figure 78. Finalised sizing and placement of the infuser label and branding.

Figure 79. Final infuser CAD model with finalised branding and labelling (including information hierarchy).

Figure 80. Low fidelity prototyping of the final infuser label.

Figure 81. The finalised infuser (CAD model).

Figure 82. Cutaway of the final infuser.

Figure 83. Exploded view of each of the key infuser parts.

Figure 84. Initial infuser bag exploration sketches.

Figure 85. Refine infuser bag sketches.

Figure 86. Low fidelity bag pattern prototyping.

Figure 87. Initial fabric testing of the infuser bag.

Figure 88. Low profile waist bag concept,

Figure 89. Across body infuser bag concept.

Figure 90. Infuser storage bag aesthetic mood board.

Figure 91. Refined infuser bag concept sketches.

Figure 92. Example of exploration of a bag strap extension.

Figure 93. Infuser slot orientation exploration, side slot.

Figure 94. Infuser slot orientation exploration, top slot.

Figure 95. Infuser slot orientation exploration, front slot.

Figure 96. Exploration of three different infuser bag designs.

Figure 97. Infuser bag concepts evaluation matrix.

Figure 98. Final bag concept.

Figure 99. Refined bag prototyping using neoprene.

Figure 100. Dressing form and IV connection mechanism ideation and refinement.

Figure 101. Annular joint IV clip CAD model.

Figure 102. Slide fit IV clip CAD model.

Figure 103. Threaded IV clip CAD model.

Figure 104. Slide locking IV clip CAD model.

Figure 105. Gutter lock IV clip CAD model.

Figure 106. 3D printing testing of the IV clips.

Figure 107. IV Clip Evaluation Matrix.

Figure 108. Refined IV clip sketches.

Figure 109. IV clip and dressing evaluation matrix based on IV clip sketches.

Figure 110. Further sketch exploration of the IV clips and a dressing for the PICC line.

Figure 111. Dressing prototyping with a woven dressing.

Figure 112. Reusable IV clip and external dressing exploration.

Figure 113. Exploration of using a Tegaderm dressing for the IV clip.

Figure 114. User testing of the IV clip.

Figure 115. Multi-piece IV clip concept.

Figure 116. Further user testing of the IV clip.

Figure 117. Exploration of adding a pull tab to the IV clip.

Figure 118. Initial multi-piece IV clip CAD modelling.

Figure 119. Refined multi-piece IV clip CAD model.

Figure 120. Finalised multi-piece IV clip CAD model.

Figure 121. An initial exploration sketch of the single-piece IV clip concept.

Figure 122. Initial single-piece IV clip CAD modelling.

Figure 123. Developed CAD models of the single-piece concept.

Figure 124. Single-piece IV line clip prototypes exploring scale and form.

Figure 125. Flexible single-piece IV line concept exploration.

Figure 126. IV clip placement exploration.

Figure 127. Final IV clip concepts presented to users during the second expert critique sessions.

Figure 128. The IV clip concepts presented to the expert critique session participants.

Figure 129. IV clip aesthetic mood board.

Figure 130. CAD illustration showing how the IV joints could be slid into the IV-line holder.

Figure 131. Exploration of the form of the IV-clip system.

Figure 132. Refined sketches of three different IV clip designs.

Figure 133. One-piece IV clip concept, CAD model.

Figure 134. Two-piece IV clip concept, CAD model.

Figure 135. Flexible IV clip concept, CAD model.

Figure 136. IV clip prototyping exploration.

Figure 137. Evaluation matrix of the three developed IV clip solutions.

Figure 138. The refined version of the IV clip based on concept one.

Figure 139. IV clip based on the third expert critique.

Figure 140. An alternative design to the vertical slotted IV clip with a horizontal slot.

Figure 141. CAD models exploring the aesthetic of the IV clips.

Figure 142. The IV clips were 3D printed and tested to explore function with the IV lines and comfort.

Figure 143. A further refined concept of the IV clip.

Figure 144. An image used to compare each of the IV clip concepts.

Figure 145. Prototyping testing with the 3M silicone securement system.

Figure 146. Finalised IV clip concept exploration. CAD model.

Figure 147. The finalised IV clip. CAD model.

Figure 148. Hartford, J. (2015). Interrad Medical Sees Opportunity in Securing Catheter Lines. MDDI. <https://www.mddionline.com/components/interrad-medical-sees-opportunity-securing-catheter-lines>

Figure 149. Recoloured PICC line concept.

Figure 150. The existing shower storage solution.

Figure 151. Exploration sketches of shower storage systems.

Figure 152. Prototype of the first concept being tested in the shower.

Figure 153. CAD model of the first shower concept.

Figure 154. Prototype of the second concept being tested in the shower.

Figure 155. CAD model of the second shower concept (a cradle form).

Figure 156. Prototype of the shower hook and infuser storage pouch for use with the hook.

Figure 157. CAD model of the shower hook concept.

Figure 158. A second shower bag concept with a vertically oriented bag.

Figure 159. CAD modelling exploration of the positive pressure valve.

Figure 160. The prototype of the IV protection sleeve. Shirt sleeve down.

Figure 161. The prototype of the IV protection sleeve. Shirt sleeve up.

Figure 162. The finalised shower storage hook.

Figure 163. The resized shower clip with the neoprene storage bag in the shower.

Figure 164. The infuser and storage bag worn on a user.

Figure 165. A final prototype of the IV clip adhered to a user's arm.

Figure 166. The final infuser prototype.

Figure 167. The infuser shower bag adhered to a shower wall.

Figure 168. Detailing of the infuser storage bag and infuser label.

Figure 169. Each part of the main infuser system.

Figure 170. Details of the IV joints when mounted in the IV clip.

Figure 171. The prototype infuser laid out on the infuser change sheet.

Figure 172. A user wearing the simple sleeve to cover and protect the IV clip and IV lines.

Figure 173. All elements of the re-designed OPIVA system laid out and labelled.

Contents

00. Preface	01 - 27
01. Positioning the Researcher	28 - 31
02. Introduction	32 - 37
03. Contextual Review	38 - 71
03.1. OPIVA	40 - 51
03.2. Medical Device Use and Misuse	52 - 55
03.3. Design Considerations	56 - 69
03.4. The Research Opportunity	70 - 71
04. Methodology	72 - 109
04.1. Methodological Frameworks	76 - 79
04.2. Research and Creative Methods	80 - 106
04.3. Ethical Considerations	107 - 109
05. Research Documentation	110 - 351
05.1. Context Building	112 - 121
05.2. Discovery Through Ideation	122 - 127

05.3. <i>Understanding the Patient</i>	128 - 140	09.5. <i>Appendix E.</i>	439 - 440
05.4. <i>Initial Design Brief</i>	140 - 143	09.6. <i>Appendix F.</i>	441 - 446
05.5. <i>Ideation</i>	144 - 163	09.7. <i>Appendix G.</i>	447 - 452
05.6. <i>Stepping Back - Refining the Design Brief</i>	164 - 167	09.9. <i>Appendix H.</i>	453 - 455
05.7. <i>Refined Ideation</i>	168 - 351		
06. <i>Research Outcomes</i>	352 - 367		
07. <i>Discussion</i>	368 - 383		
07.1. <i>Design Research Outcomes</i>	371 - 375		
07.2. <i>Recommendations and Limitations</i>	376 - 382		
08. <i>References</i>	384 - 409		
09. <i>Appendices</i>	410 - 455		
09.1. <i>Appendix A.</i>	411 - 414		
09.2. <i>Appendix B.</i>	415 - 426		
09.3. <i>Appendix C.</i>	427 - 428		
09.4. <i>Appendix D.</i>	429 - 438		

01. Positioning the Researcher



Figure 1. Weatherly, K. (2019). *The Kiwi - Painless Dental Anaesthetic*.

About me...

I spent much of my early life in hospitals as a child with a chronic lung disease, Bronchiectasis. Growing up in and out of hospitals gave me a wealth of personal experiences with both inpatient and outpatient care. I have had my fair share of both negative and positive experiences with hospital care. These experiences, combined with my industrial design background and desire to design to improve the lives of others, led me to focus my research on the experiences of patients in New Zealand's health care system.

My journey as a designer in health care began when I had the opportunity to work with the University of Auckland and Otago University during the last year of my undergraduate degree. This research explored how local anaesthetic could be delivered using needle-free technology (Weatherly, 2019). This first-hand experience led to me becoming invested in finding out how design could improve people's lives.

02. Introduction

Outpatient intravenous antibiotic (OPIVA) treatment was a service provided by Auckland's Waitematā District Health Board (Waitematā DHB). Patients with serious bacterial infections, such as sepsis or meningitis often need long periods of aggressive antibiotic treatment (Khardori, 2014). However, these long treatment periods (6 to 8 weeks) can take up valuable bed space in hospitals, putting patients at risk of hospital-related infections and costing hospitals money (Shepperd et al., 2016). The OPIVA treatment used a peripherally inserted central catheter (PICC) and an automatic antibiotic infuser to provide patients with antibiotic treatment. In 2016 across New Zealand, patients receiving OPIVA treatments saved approximately NZ\$5 million in inpatient related costs (Kumari et al., 2018). Since its introduction to the Waitematā DHB in 2000, demand had increased steadily from an initial 150-200 patients per year to as many as 400 in 2020 (Personal Communication OPIVA Nurse Expert Interview, November 30, 2020; Kumari et al., 2018).¹ During treatment, patients changed their antibiotic infuser daily while a district nurse (DN) visited weekly to change the PICC line's sterile dressing and take blood (to ensure the antibiotics are working). Both dressing and infuser changes were time-consuming and carried serious infection risks (Upton et al., 2004). The literature was limited with respect to patient experiences within OPIVA services, and available research was primarily focused on patient health outcomes rather than patients' emotional experiences (Castner et al., 2008).

Although supported by doctors in the Waitematā DHB, patient education and management in the OPIVA service were run by nurses. The OPIVA service was disciplinarily diverse (pharmacists, nurses, doctors, and hospital management). However, nurses played the leading role. Nurses are health care professionals who provide supportive and preventative care for sick, disabled or dying

¹ References to the existing Waitematā DHB OPIVA service's function were largely gathered from personal communications with hospital staff during expert interviews and during an expert critique session. Specific discussions were highlighted in the documentation of the research chapter.

people while simultaneously managing health care systems and education (Hendrickson et al., 1990; Kitson et al., 2010). Nurses are often required to balance the technical skills and knowledge needed to care for patients' medical needs while remaining empathetic and understanding their psychosocial needs (Hendrickson et al., 1990; Kitson et al., 2010). Kitson et al. (2010) define patients care as patient safety, medication control, preventative care, communication with patients, nutrition, hygiene, comfort (pain management and physical comfort) and patient privacy/dignity. The skills and technologies required to provide patients with treatment were referred to by Cestari et al. (2015) as 'hard' and 'soft' health-care technologies. Hard health-care technologies were defined as medical devices, including instruments and "treatment hardware". Soft health-care technologies were defined as the relationships and emotional care clinical staff share with patients. Both hard and soft technologies are required for complete patient care (Feitosa Cestari et al., 2015).

The hard technologies used during patient treatment have often been developed, focusing only on the patient's clinical needs or how treatment can be as cheap and time-efficient as possible, sometimes neglecting ease of use and accessibility (Barton, 2009; Money et al., 2011). Designing medical devices for ease of use and accessibility was imperative to successful treatment (Shah & Robinson, 2007). Improper use of medical equipment was one of the leading causes of adverse medical events associated with device-based procedures (Rangel Ribeiro et al., 2016). Along with a focus on cost and time efficiency, medical devices' development often fails to include nurses or patients in the design process (Castner et al., 2016; Money et al., 2011).

Medical product developers are responsible for improving nurses' ability to provide efficient and effective care when creating new devices (Powell-Cope et al., 2008). However, the development of new devices has often overlooked the needs of nurses and patients (Castner et al., 2016; Money et al., 2011). In

addition, many nurses have found it challenging to balance fundamental care and the use of specialised medical devices with the rapidly changing technology they were required to learn to use (Zhang et al., 2014). This research aimed to illustrate how HCD and product design could highlight patients and nurses' experiences to improve existing medical devices to meet their needs, beyond just cost savings.

03. Contextual Review

03.1. OPIVA

The Contexts of the OPIVA Service

OPIVA and the Waitematā DHB

OPIVA treatment in the Waitematā DHB comprises several vital systems that work together to treat patients. Product, service and communication design elements came together to support each part of the patient’s journey through their treatment. The OPIVA system of products consisted of three main items: the peripherally inserted central catheter (PICC) line and IV line; the elastomeric infusion device; and two storage methods for the infuser (a waist bag for day-to-day activities and a shower storage bag). The infuser was constructed from clear Polyethylene terephthalate (PETE) plastic. The elastomeric reservoir, which constricts to infuse the antibiotics, was made from Polyisoprene (Baxter, 2017; Hamilton & Sahatjian, 2012). The white IV connector at the end of the IV line allowed the infuser to be threaded onto the patient’s IV. This connector acted as a flow restrictor, containing a small glass capillary tube to restrict and control the flow of antibiotics to the required rate (10ml per hour) (Baxter, 2017). Patient information was printed on an adhesive label applied to each infuser before shipping to the patient (Personal Communication OPIVA Pharmacist Expert Interview, November 5, 2020).

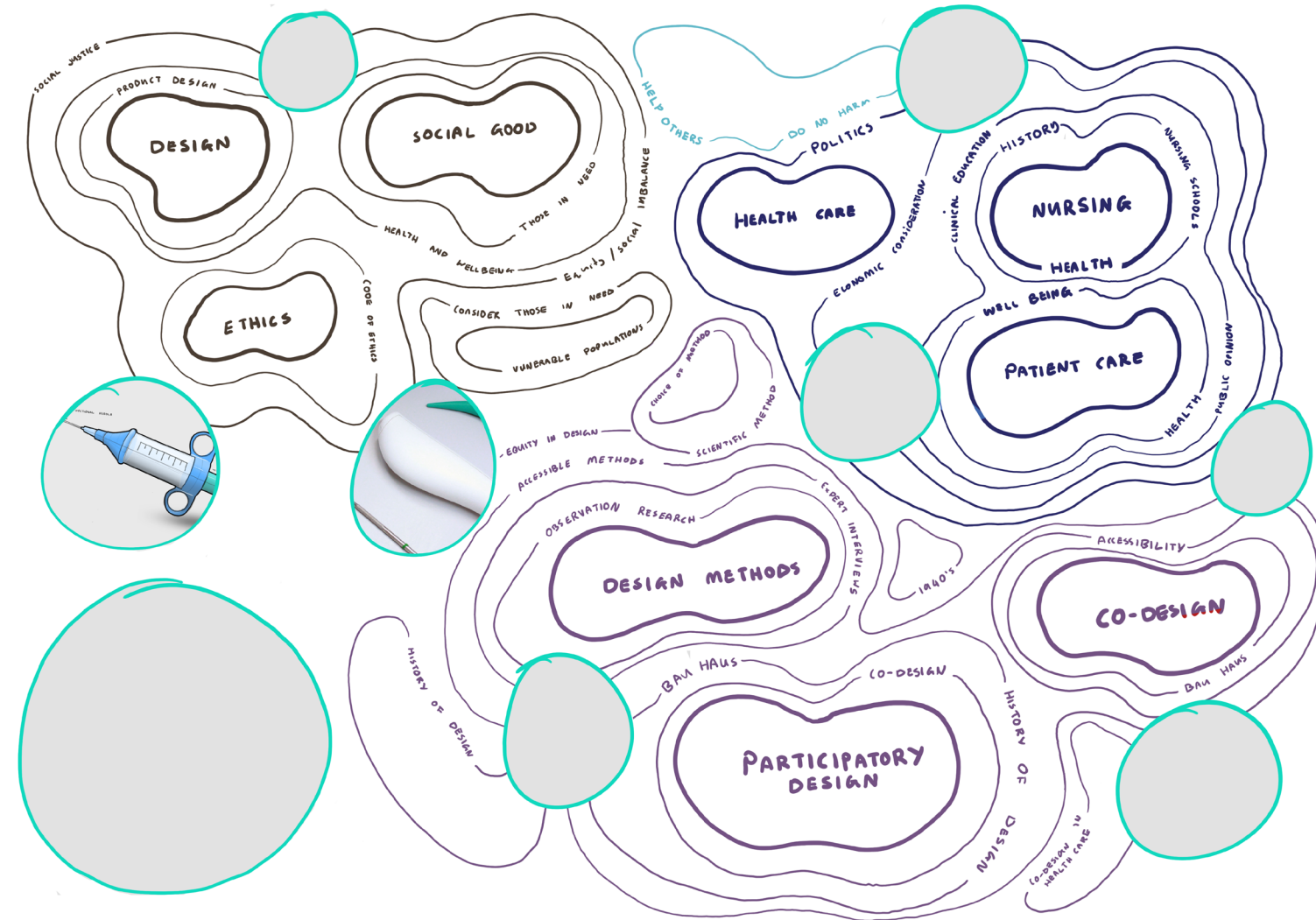


Figure 2. Contexts of the research. Exploration of contexts through brainstorming.

Many different medical treatments use PICC lines, from chemotherapy to liquid nutrition (Johansson et al., 2013). PICC lines are a long slender silicone or polyurethane tube that is inserted into a patient through a central vein to access their heart (Smith & Nolan, 2013). For treatments that require extended use of caustic medicines, PICC lines are used to ensure veins used for treatment are not damaged during the treatment. The PICC line is usually anchored outside the body using a stabilisation clip and then covered with a transparent antiseptic dressing. In existing OPIVA treatments, this dressing was not waterproof and was often a cause of irritation and allergic reactions for patients (Jeanes & Martinez-Garcia, 2016). Because of their central vein access, PICC lines can cause severe blood infections (sepsis) if care is not taken during dressing changes. In addition, when dressing changes occur (weekly), the PICC line can be accidentally removed from the body (PICC line migration), which would necessitate a new PICC line (Kumari et al., 2018). Regardless of the treatment, using a PICC line can be distressing for patients (Ojo, 2020).

The IV line running between the PICC line and the antibiotic infuser must not have any kinks or sharp bends in it. Any hindrance to the flow of the antibiotics could have caused the treatment to be ineffective (Webb, 1984; Personal Communication OPIVA Nurse Expert Interview, November 30, 2020). The Waitematā DHB's OPIVA system used several strips of surgical tape placed at points along the upper arm to avoid kinks in the IV line and hold the flow restrictor in place. The tape was changed along with the dressing once per week. The complex tubing system was covered with a standard elastic tube bandage sleeve to protect the IV line and taping in day-to-day activities. While showering, patients wrapped their arm in clear film plastic wrap to preserve the dressing and IV line. The plastic wrap was discarded after each use and created considerable waste during day-to-day activities (Personal Communication OPIVA Nurse Expert Interview, November 30, 2020). The OPIVA system was used by users from all adult age ranges (17 to 100 years of age).



Figure 3. The existing OPIVA IV line and PICC line system. Showing three IV lines: PICC line, IV line extension, and Infuser IV line.

For most long term intravenous antibiotic treatment in the outpatient setting, elastomeric infusers were used (Li et al., 2018). In the Waitematā DHB, the infuser of choice was the Baxter brand. The infusers used by the OPIVA service had a 240ml volume with a 24-hour infusion period. Patients were expected to change the infusers themselves every 24 hours. Some patients did not have the dexterity or ability required to change the infuser each day. In these cases, the responsibility was placed on a family member that they lived with or a DN visited daily to perform the infuser changes.

Most antibiotics used in the OPIVA service needed to be stored in a refrigerated space as the antibiotics used were perishable (Baxter, 2017). The infusers were sent to patients weekly (seven infusers) in a large box. Ice packs and insulating protective wrap were used to keep the infusers protected and cool. The box, packaging, and used infusers were then discarded, resulting in a considerable amount of excess medical waste.

Along with the box used to ship the infusers, the infuser's outer shell was recyclable. However, the infuser shell needed to be disassembled from the IV outlet for this to happen and could result in patient injury if done incorrectly (Personal Communication Clinical Expert Interview, November 30, 2020).

The infuser supplied to patients in the Waitematā DHB was stored in a small waist bag during day-to-day activities and then a mesh bag when showering. The IV line ran out from the waist bag and was routed up and under the patient's top item of clothing (e.g. shirt). Baxter provided these bags to the hospital to give to new patients and only had one size. The lack of size options meant that patients outside the average body dimensions had to join two bags together to fit them if their body were larger than average.

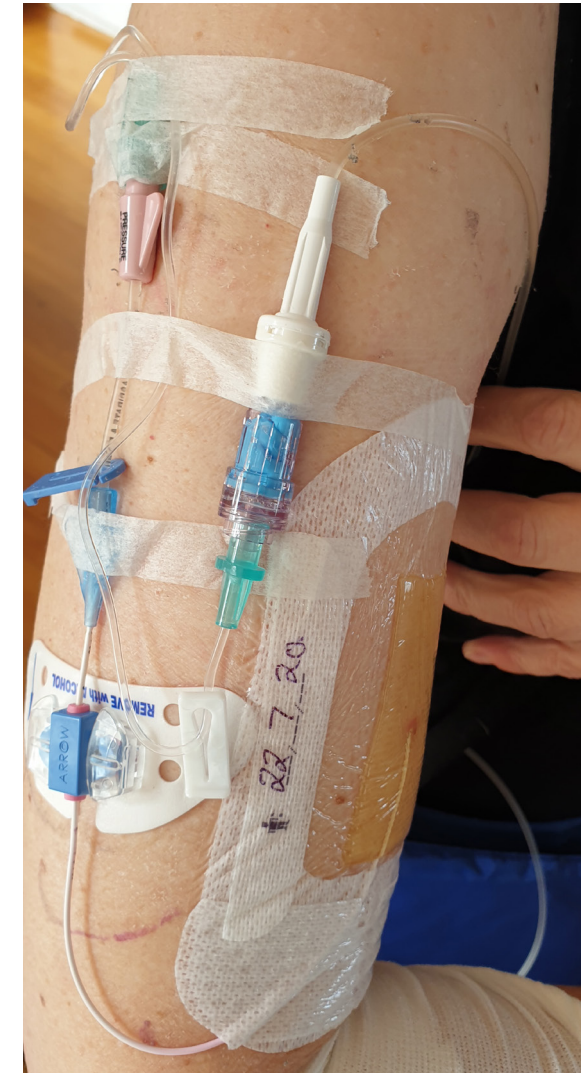


Figure 4. The OPIVA treatment system fitted to a patient (PICC line, IV extension, positive pressure valve and the flow restrictor).

History of OPIVA and Elastomeric Infusion Treatment

This research centred on the OPIVA system offered through the Waitematā DHB. The OPIVA service used an elastomeric infusion pump made by Baxter. Elastomeric infusion is a method of IV fluid infusion without requiring gravity or electronics to control the flow (Hamilton & Sahatjian, 2012). Elastomeric infusion is a relatively low-tech form of IV infusion. By using an elastic reservoir to pump medicine slowly, the elastomeric infusers are relatively tamper-proof, making them practical for outpatient use. These pumps can deliver many different drugs. These include chemotherapy, pain medication and antibiotic treatment. In addition, the infusers are typically small and light, allowing them to impact patient's day-to-day life less. The Baxter branded infusion pumps used in the OPIVA service were small disposable blow moulded bottles shaped like a baby bottle. Inside was an elastomeric balloon that constricts, creating the flow of drugs. The bottle's main elastomeric reservoir remains largely unchanged between brands, with the key differences being in the outer shell. Some brands will have a flexible PVC outer, while others (such as the Baxter Intermate, used by OPIVA) use a more rigid outer shell as described above.

The primary focus of this research was on patients' experiences, and the research aimed to identify opportunities to improve patient's experiences associated with the OPIVA system. Working on this basis, considering studies that analysed patient experiences of similar services was an effective starting point to understand the research subject. Dodd (2007) discussed elastomeric infusion devices used in home-based treatment for cystic fibrosis (CF). His research found that aside from cost savings associated with outpatient care, IV therapy at home dramatically improved CF patients' quality of life. In Dodd's (2007) literature review of research within PubMed (research published between 1980 and 2007), several studies (Valente & Aldrete, 1997; Capes & Asimwe, 1998; Thiveaud et al., 2005) focused on the performance and cost of

pumps and three studies discussed patient preference (Rich, 1992; Zahnd et al., 1999; Capdevila et al., 2003). Dodd (2007) provided twenty-four patients with a questionnaire about their experiences during CF treatment. The study found that the patient preference of the infuser brand primarily focused on the pumps' comfort and discreetness. Patients generally preferred the Eclipse brand device. Eclipse branded infusers featured a polyvinyl chloride (PVC) outer shell to protect the device. This soft shell allowed the whole device to deflate as the drugs were infused. Participants felt that the lower weight and size significantly benefited the Eclipse model over other models. Participants reported that the Eclipse model featured an opaque outer shell that made checking infusion rate more challenging (Dodd, 2007). However, this was stated not to impact significantly patient preference, and discreetness of the Eclipse model meant it was preferred over hard shell infusers.

Kumari et al. (2018) explored patient experiences in the context of the OPIVA service in Auckland. This research aimed to explore patients' experiences (aged 15 and older) at Auckland Hospital in the OPIVA service (Auckland District Health Board's OPIVA service). The paper discusses this therapy's history and background as it started in 1979. The Auckland District Health Board (ADHB) was the first in New Zealand to offer IV-based 'take home' antibiotic treatment (Kumari et al., 2018). This treatment was essential for patients who required long-term IV dosages of antibiotics. The benefits were viewed as freeing up hospital beds, reducing costs and avoiding risks of hospital-related injuries and sicknesses (Chambers et al., 2019). There were approximately 150-200 OPIVA patients treated each year at Auckland hospital, and it was estimated to have saved nearly 4000 days of bed usage for this treatment in 2016 (Kumari et al., 2018).

Kumari et al. (2018) focused on patients' experience with OPIVA and identified areas that could be improved (specifically patient experience). The study used a questionnaire to survey OPIVA patients and identify issues they faced in their treatment. The main areas that caused problems for patients were inconsistent communication between hospital and DNs and difficulties with specific system elements. Issues with the system included: kinks forming in the IV lines or reactions to the dressing (Kumari et al., 2018, p. 22).

The researchers made several recommendations based on the study outcomes: these included improving the education for both care providers and patients around OPIVA and including family/friends of patients in the OPIVA processes so that communication and knowledge-based errors and issues were less likely to occur (Kumari et al., 2018, p. 24).

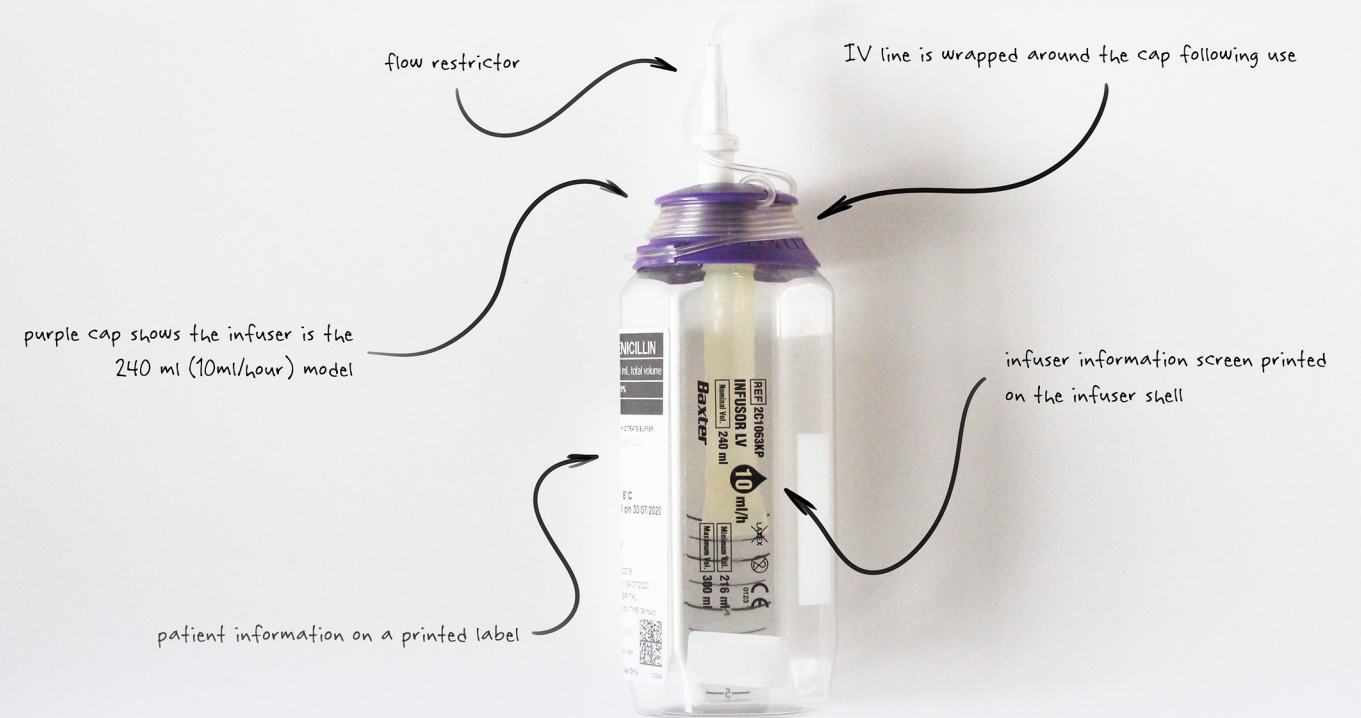


Figure 5. The existing Baxter branded infuser used by the OPIVA service.

Existing Market Analysis

I asked each clinical staff participant for their opinions on the Baxter infuser used in the OPIVA service and what experience they had working with other brands of antibiotic infusers. Every clinical staff member I spoke to only had experience working with the Baxter branded infusers, and none were aware that there were other brands of infusers available. As I have already highlighted, patients preferred other brands of elastomeric infusers over Baxter (Dodd, 2007). Therefore, I wanted to explore what elements (both functionally and aesthetically) separated the Baxter infuser from other brands of elastomeric infusers (like Eclipse).

The Baxter brand infuser was a relatively simple product with an elastomeric reservoir encased in a hard plastic shell. The plastic shell was recyclable but was press-fitted onto the protective cap, which can be challenging to remove. The cap of the infuser was simple but well designed, with the IV line being wrapped around it during storage and disposal. Clinical staff noted that the infusers were prone to breaking and leakage; therefore, they lacked durability. The infusers were bulky and did not change size as they emptied.

Several other elastomeric infusion pumps (manufactured by other brands) were used for various purposes in other treatment services internationally—these ranged from antibiotic infusion to the delivery of chemotherapy drugs used with cancer patients. Baxter infusers have a hard outer shell with a soft reservoir inside them. Like those produced by Wolf Medical or Eclipse, most other brands use a thick, soft plastic (PVC) outer shell for their infusers. These infusers could not be dismantled and were likely less sustainable than the infuser produced by Baxter. However, as Dodd (2007) discussed, patient preference generally leans more towards soft shell infusers due to their smaller size and easier positioning under clothing.

Image removed for copyright reasons.
<https://www.wolfmed.com/blog/elastomeric-pump-uses>.

Figure 6. Wolfmed, (2021). A selection of elastomeric pumps from Wolf Medical. Used by the OPIVA service.

03.2. Medical Device Use and Misuse

Medical device design and use analysis

When working within a medical setting, end users' safety should be the starting point of research (Kohn et al., 2000). For medical devices, avoiding adverse medical events is of critical importance in the development process. An adverse medical event (AME) is an event that occurs in a medical environment that directly harms a patient (Leistikow, 2017; Kohn et al., 2000). AMEs could be a mistake by a medical professional or a failure of a piece of equipment. Often these events are avoidable and preventable (Leistikow, 2017). AMEs do not generally include intentional error. However, often separating deliberate harm and human error can be challenging (Scragg, 2003). A key issue leading to adverse medical events (associated with human error) was the misuse and lack of understanding of how to use medical devices (Wilson et al., 1999).

Wiklund et al. (2011) explored examples of misuse in medical devices and how to remedy these through usability testing. They promote the use of usability testing to protect patients from injury or death. "Too many people have been injured or killed because someone pressed a wrong button, misread a number, misplaced a component, skipped a step, or overlooked a warning message when using a medical device" (Wiklund et al., 2011, pp. 10). Wiklund et al. (2011) discussed how medical devices could be tested and designed to ensure safe and effective use with patients. Wiklund (2005) discussed the critical ways that medical products can be misused and how to address these in the design of the devices. These include the following (Wiklund (2005):

Preventing Misuse: Medical device development companies often address misuse through design that aims to prevent misuse. For example, this could be achieved by designing a device with a one-piece shell rather than using screws to avoid being taken apart. Avoiding misuse can also be achieved by providing training or instructional material with devices that address possible misuse and educate users on the correct usage. Wiklund (2005) highlighted that warnings were often placed on devices addressing misuse as this was cost-effective and protected manufacturers from potential lawsuits caused by misuse.

Persistent forms of misuse: A product may be misused consistently and commonly. An example of this was when IV pumps designed to be used by a trained professional were sent home with patients and managed by untrained users in a home environment. This unintended use created issues around who should be held liable if an error occurred. One solution was to develop products that directly fill these voids (voids where a product was being misused to fill a market gap). An example of this was surgical tools designed by Bresslergroup with retractable guards to protect surgeons and nurses from accident injury (Sibanda, 2020). Such products can address the misuse of another product by being explicitly designed to address the cause of the misuse.

Drawing the line: In some cases, misuse may be unavoidable and designing features that address this was sometimes needed. For example, often, single-use syringes may be used multiple times, potentially exposing multiple people to risk. As a result, to avoid being abused, hypodermic needles can be designed to become unusable after a single use, like preventing misuse, directly designing features that stop specific products' misuses is a more direct approach.

Characterising 'correct' product use is another area of importance when designing products (Trombetta & Wilson, 1975). For example, it can be important to consider what should be labelled a misuse and what should be regarded as unintended use. Of course, the user's safety should play a significant role in decision-making. Still, all possible ways a product could be misused should be considered and addressed where possible in a design process (Wiklund, 2005).

Addressing the misuse of products is a vast area of study that directly influences product design as a discipline (Göhler et al., 2018). Ensuring that products are intuitive and effective should always be a key driver in the product design process (Blackler et al., 2003). Within medical product design, the need for safe and intuitive design is even more necessary (Kohn et al., 2000).

03.1. Design Considerations

Design Ideologies and Considerations

Human-Centred Design and Participatory Design

Participatory design focuses on giving end-users the power to have more direct involvement in the design process. Participatory design ideologies began in the 1970s, an offshoot of western societies desire to have more control of their lives along with the influences of Scandinavian design (Simonsen & Robertson, 2013; Bannon & Ehn, 2013; Hartswood et al., 2002; Sanders & Stappers, 2008). These ideas were first applied in a health care setting by the Florence Project in 1983 (Bjerknes & Bratteteig, 1987). The Florence project brought designers and nurses together to explore design-led solutions (a new filing system) to support nurses. The designers spent time learning with the nurses to understand them better. This learning time was combined with sessions where the designers educated the nurses on design (mutual learning). The result was the 'Nursing System', which aimed to create a patient reporting system.

Human-centred design (HCD) is a design ideology and methodology coined by Donald Norman in the 1980s (Norman & Draper, 1986). HCD aims to centre the design process on the user and involve them throughout the entire design process (Norman & Draper, 1986). HCD can help design research to keep the end-user and their needs central to the design process and creates innovative solutions that were made directly for their needs (Boy, 2011). HCD involves observing and learning from end-users while avoiding assumptions about their needs (Harte et al., 2017). The International Organization for Standardization

in 2010 defined HCD in ISO 9241-210 as “an approach to systems design and development that aims to make interactive systems more usable by focusing on the use of the system and applying human factors/ergonomics and usability knowledge and techniques” (International Organization for Standardization [ISO], 2010). HCD is based on the philosophy of universal design (Steen, 2011). Universal design aims to create products and services through design that are accessible to all users regardless of their cognitive and physical abilities (Null, 2014). Although Universal Design’s ideas are essential to HCD, often, HCD will focus on a specific user group. HCD takes an interdisciplinary approach to the design process to ensure that the end-users needs are met (Bazzano et al., 2017).

Product Design in Healthcare

In the mid-1900s, design researchers started to explore how the problem-solving approach of design could tackle some of the often systemic issues with modern health care systems (Bjerknes & Bratteteig, 1987). Although these were often service design-focused, the goal was to improve the experiences of patients and medical staff.

The literature surrounding the use of HCD methods in medical device development suggests that HCD was beneficial for the success of products (Money et al., 2011). However, many medical device manufacturers did not use these methods due to them valuing the views of senior health care management staff (those in charge of product purchasing) over patients' views (Money et al., 2011). As a result, many existing products used within a medical setting were designed without the involvement of end-users or the use of HCD methods (Shah & Robinson, 2007). The inclusion of end user's experiences in the design process has been explored through a growing body of literature. These research projects have identified that involving end-users (both clinical and non-clinical users) more in the design process can lead to more successful product outcomes (Castner et al. 2008; Dickson et al., 2017; Reed et al., 2015; Parbhu et al., 2019; Money et al., 2011). To highlight how design can better include the experiences of users towards creating more successful products, I have outlined six examples of product design in health-care settings that worked closely with end-users and that I think effectively balanced usability and pleasing aesthetics.

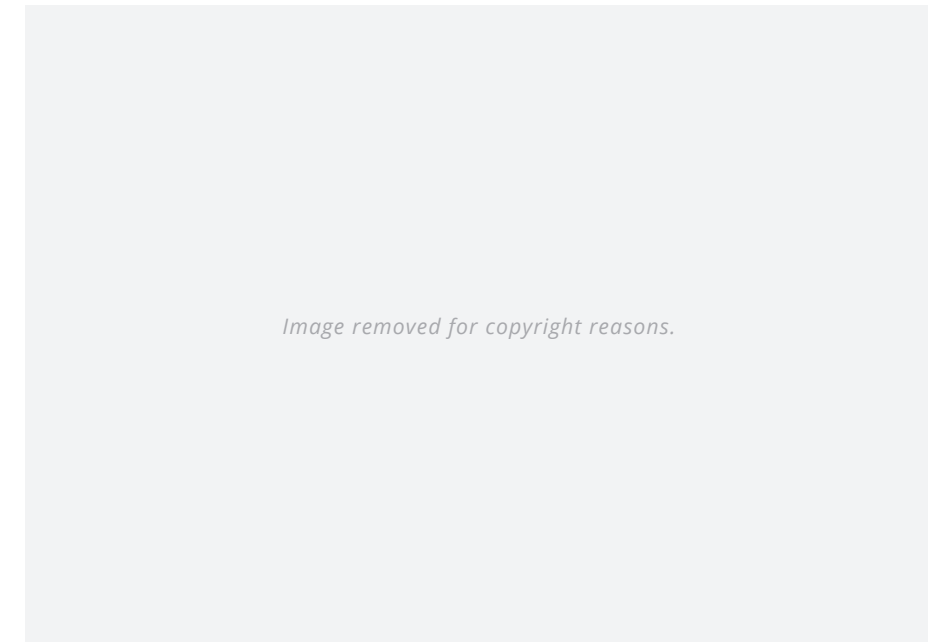


Figure 7. Dickson, (2017). A redesign of the tracheostomy tubing system.

Dickson (2017) recognised that tracheostomy tubes were essentially unchanged since the 1870s and redesigned them using HCD and co-design methods. She explored how both precious and jewellery-like aesthetics could have a place in medicine. By working with people who used tracheostomies, she was better able to understand the issues present in the existing system and explore solutions (Dickson et al., 2017). Dickson's (2017) work largely centred around the stigmas associated with medical treatments and how these could be both made visible and remedied through co-design research methods. Dickson's product outcome challenged the medical aesthetic and presented an elegant alternative that valued users at the centre of the design process.

Image removed for copyright reasons.

Figure 8. Reed et al., (2015). A solution for patients living with motor neurone disease developed using Co-Design methods to explore usability, user comfort and aesthetics.

Reed et al. (2015) explored how co-design workshops conducted with people living with motor neurone disease (MND), designers, clinicians and caregivers could be used to design a cervical collar that better meets the needs of people living with MND. MND is an incurable, progressive neurodegenerative disease that affects the brain's ability to control muscles, leading to difficulty speaking, breathing, any physical movement and eventually death (McDermott & Shaw, 2008). Patients with MND will often struggle to support their heads.

The inability to support the head through musculature in the neck can lead to difficulty swallowing, breathing, and communicating. Reed et al. (2015) found that existing cervical support collars were used to support patients with this 'head drop'. However, these were often uncomfortable for the patient (Reed et al., 2015). The team developed a collar that had an appearance more typical of clothing than a medical product, and that was customisable to the patient to allow for ample support while still giving flexibility of movement for day-to-day activities. The collar was designed to meet both patient needs (comfortable, aesthetically acceptable, and easy to use) and functional requirements (support with movement, customised support, and adjustable with the progression of the disease).

Image removed for copyright reasons.

Figure 9. Parbhu, (2015). An IV pole redesign for children with a focus on improving the experiences of children.

Parbhu (2015) explored how products designed for paediatric hospitals could include children more in the design process. One of the key findings within Parbhu's research was around her expectations of developing a product for use in hospitals versus the actual process she went through. Parbhu (2015) found that managing the hospital senior management and the hierarchy of the hospital made the project significantly more complex (Parbhu, 2015, p. 100.). She recommended that to better allow for partnership in the research, including a representative from the hospital throughout the study was crucial. Parbhu et al. (2019) built on this research to conclude that including children's voices, their parents/caregivers and nurses was beneficial to the design of medical products used by children.

Image removed for copyright reasons.

<https://www.fphcare.com/nz/homecare/sleep-apnea/masks/evora-nasal-mask/>

Figure 10. Fisher & Paykel Healthcare, (2020). Evora Mask.

Obstructive sleep apnoea (OSA) is a condition in which people will experience disturbed sleep because of breathing difficulties (apnoea) (Sacchetti, & Mangiardi, 2012). OSA is often managed with the use of continuous positive airway pressure therapy (CPAP). This therapy involves constant airflow to help open the users' airways and help maintain normal breathing. However, CPAP masks were often bulky and required several straps to hold in place; Fisher and Paykel Healthcare designed a compact version of the CPAP mask that was designed to fit easily over the head like a cap, focused on non-clinical ease of use ("Evora Nasal Mask", 2021). This system helped to prioritise usability while exploring a more 'pleasing' aesthetic than is often used in CPAP masks.

Image removed for copyright reasons.
<http://www.craigmcgarrell.com/sensilemedical>.

Figure 11. McGarrell, (2018). Sensile Medical.

Sensile Medical Design Language (McGarrell, 2021) was a research project exploring a re-design of a range of medical products produced by Sensile Medical. Sensile Medical and McGarrell designed a family of drug delivery related products. These included two wearable injectors (for delivery of drugs over several hours), a drug reconstitution device and a bolus injector (a device for providing drug administration quickly) (McGarrell, 2021; "Intravenous Bolus", 2012). Although each product is built for a slightly different purpose, McGarrell (2021) aimed to create a consistent design language and improve the ease of use across their product range. The ease of use and consistent design language was achieved by using specific materials and design features (thinner plastic and textures) to communicate which elements of the system were disposable and which should be retained (the injector Luer/needle and display/icons, respectively) (McGarrell, 2021). In addition, these products were wearable devices, and they were designed around being comfortable to wear under clothing and easy to use without needing to remove the clothing.

Image removed for copyright reasons.
<https://www.behance.net/gallery/103052883/ohc-Home-Breath-Analysis>.

Figure 12. Couto, (2020). OHC – Home Breath Analysis.

OHC by Lucas Couto challenged the design of breath analysis machines by removing the typically medical aesthetic associated with these products (Couto, 2020). Home Breath Analysis was designed with aesthetics as the critical focus of the design, with a separation from the typical medical aesthetic. Typically, medical products use cheap and cost-effective materials (Couto, 2020). However, OHC used similar materials and form language to what you would see in contemporary smartphones. Couto's minimal aesthetic was highlighted through the lack of colour in the parts of the system and as few visual elements as possible (Obendorf, 2009; Baxter, 1995). Minimal aesthetics can help avoid the potential for misuse of products by removing unnecessary design features and minimising the functions that can be misused (Obendorf, 2007, p. 96).

Each of these product examples considered not only the usability and function of medical devices but also the aesthetics and patient preference of devices. For example, Dickson (2017) discussed how the aesthetic value of medical products could be improved to overcome the stigmas sometimes associated with medical devices while simultaneously improving self-affirmation.

The products people own and wear play a huge role in how they view themselves and inform how society views them (Boradkar, 2010; Townsend & Stood, 2012). Townsend and Stood (2012) discussed how products' aesthetic and perceived value plays a role in self-affirmation. Products that participants viewed as more aesthetically pleasing and had a higher perceived value were found to improve participants sense of self (self-affirmation) (Townsend & Stood, 2012).

In a health-care specific setting, there was limited research around aesthetic preferences and patient outcomes with respect to medical products. Syndor & Aileen (2020) conducted research with both outpatient and inpatient departments around patient expectations for hospital furniture and found that 72.5% of patients required a "modern style" in seating and 69% required that "colour of furniture should be pleasant" (Syndor & Aileen, 2020, p. 307-308). With respect to hospital surroundings, several studies have found evidence to suggest aesthetically pleasing surroundings were associated with a positive increase in patients' health and wellness (Ulrich, 2001; Ulrich et al., 1991; Caspari et al., 2007). Ulrich (2001) found that positive distractions (art and nature) and personalisation of hospital spaces helped to reduce stress and improve patient health outcomes. Rubin (1998) reviewed 1219 pieces of literature related to health outcomes and hospital environments aesthetic and found that there was evidence to suggest a relationship between hospital surroundings and patient health outcomes. Sansoni et al. (2015) explored how the aesthetics (artificial or human-like) of prosthetics impacted amputee's

preferences. Bhuvaneshwar et al. (2007) similarly found that the positive aesthetic appeal of prosthetics played a positive role in user psychological recovery from amputation and the regaining of mobility and function. This illustrated that, at least in the case of prosthetics, the role aesthetic appeal played in patient satisfaction.

Constraints

With any medical-based research project, patients' health and well-being should always be the primary limiting constraint (Kohn et al., 2000). With all research, considering the wellbeing and care of participants should be the first step in the research process (Tseklevs & Cooper, 2017). As designers, we need to ensure we "do no harm". Materiality and construction methods were also crucial constraints for this research. The product outcome needed to be robust enough to ensure it met the patient's requirements and provided effective treatment. Based on the existing construction of the system and limitations around cost, I decided to constrain myself within the existing limits of the system. These limitations meant keeping the cost of the system as low as possible by using cost-effective materials and manufacturing methods.

Stakeholders

This research could only occur with the involvement of the Waitematā DHB and providing the researchers access to patients and clinical staff. As a result, the Waitematā DHB management was a crucial stakeholder in this project, along with the patients and clinical staff. The perspectives of hospital management, DNs, OPIVA nurses, pharmacists, doctors, and patients were needed to all be considered in this research.

03.4. The Research Opportunity

The Potential for Design Intervention

By using a contextual review, I was able to consider literature related, both directly and indirectly, to the OPIVA service. Considering the contexts which influenced both the OPIVA service but also product design in a health care setting helped me to understand the research subject better and form a framework for my research. Having considered product design research which worked with patients and clinical staff towards improving the designs of medical products, I identified a research opportunity:

How can human-centred product design be used to improve the experiences of patients receiving OPIVA treatment in the Waitematā DHB?

Based on my research opportunity and the context which existed surrounding the OPIVA service, I constructed a list of aims to guide the overall focus of the research:

- Ease of use should be the focus of design solutions for the OPIVA service. The OPIVA system effectively provides treatment to hundreds of patients per year. As a result, changes to the system needed to include direct input from the clinical staff currently involved with OPIVA (doctors, nurses, pharmacists, and hospital management) and maintain effective treatment of patients.
- Throughout my research, I found that the OPIVA service and health care more generally may reduce individuals to being 'numbers in a system'. Even with heavily interpersonal treatments like OPIVA, it can be difficult for the system to meet the needs of those engaging with them. Consequently, my design solutions aimed to improve the OPIVA system to fit a wide variety of users while ensuring ease of use and intuitive design were kept at the forefront of my process.

04. Methodology

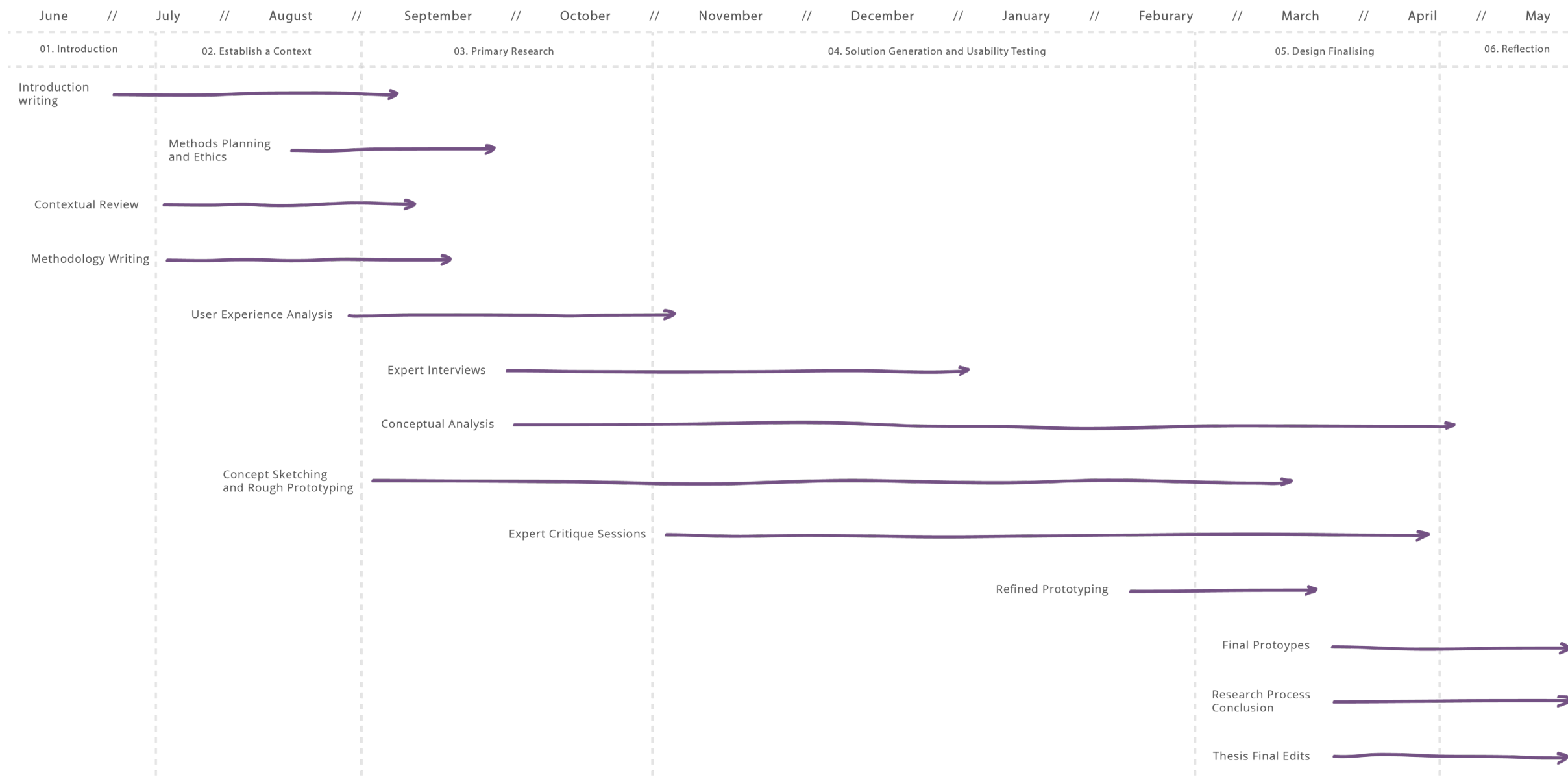


Figure 13. The research timeline.

04.1. Methodological Frameworks

The Methodological Approaches to the Research

Action Research and Mixed-Methods

This research used a mixed-methods and action research methodological approach to data collection and analysis. As a methodological framework, mixed methods allowed the research to use both qualitative and quantitative data collection methods (Plano Clark & Ivankova, 2016). Qualitative data can include personal experiences, opinions, and insights and is often more conceptual in nature (Lapan et al., 2012). In contrast, quantitative data is often collected through an 'objective' lens with data that is measurable and numerical in nature (Lapan et al., 2012). Because of the conceptual nature of qualitative data, data is often organised around the construction of common themes, allowing for further themes and concepts to develop throughout the research process (Neuman, 2014). While a mixed-methods approach helped accommodate a range of appropriate methods that were appropriate to the research and how data were analysed, action research was used to define the structure of the research (Bairagi & Munot, 2019).

Action research is a methodology that has been used to facilitate change in organisations by using a flexible, evolving research process (Parkin, 2009). Recognising that commercial and organisational barriers can make changes to medical devices difficult, action research has been proven to be an effective approach for design research in health care settings (Benger & Blackham 2009; Parkin, 2009; Ramos et al., 2020; West, 2020; Dickson, 2017). Action research is a qualitative research methodological approach that uses a cyclical

process consisting of four distinct phases: planning, action, observation, and reflection (*Figure 14.*) (Lawson, 2005; McNiff, 2013). Action Research can bring creative processes and research together through cycles of data collection and reflection (Kunt, 2020).

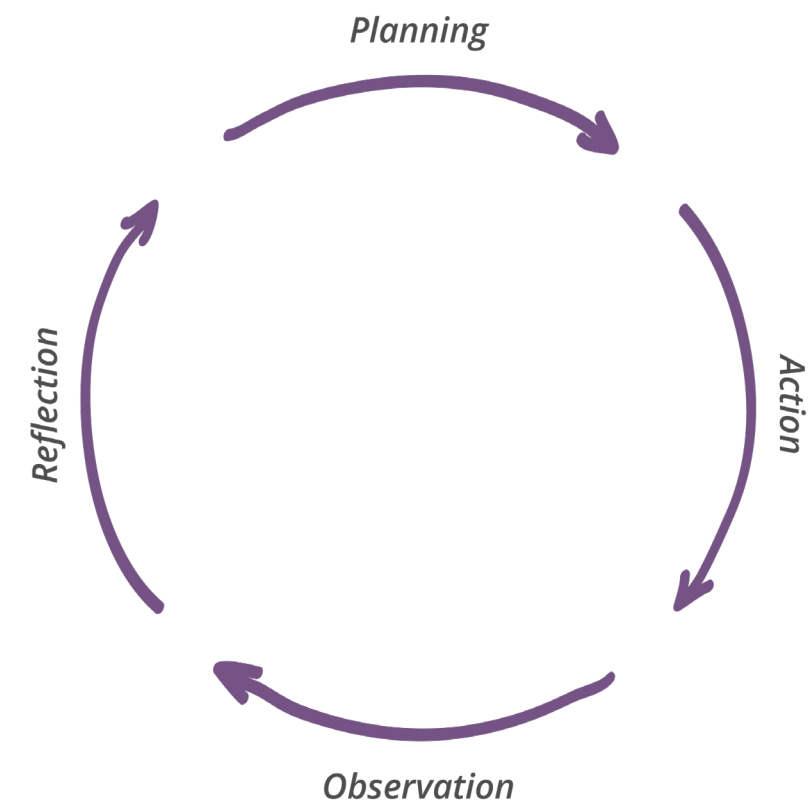


Figure 14. Willis, (2014). Action research cycle diagram.

Human-Centred Design Research

Supported by the action research methodology, this research used a human-centred design (HCD) approach to the design process. Harte et al. (2017) described a four-stage human-centred design approach to research: first, understand the end user's context; second, define the end user's requirements; third, generate solutions based on these requirements; and fourth, evaluate solutions based on the user's feedback. This 4-stage HCD approach aligns well with the 3 phases of action research. HCD provides a lens through which design decisions throughout the research can be made and provides a basis for the user to be kept as the focus of the design process throughout the research.

Along with these phases, for a project to be considered a HCD based approach, Harte et al. (2017) defined six requirements it must meet. First, the design was based on the designers understanding of the end-user, their needs, and their environment. The second was that the users were included and involved through the entire design process and development. The third was that the refinement of the design was done through user-centred evaluation. Fourth, the process was an iterative (multistage) approach. Fifth, the design considered and addressed all aspects of the user experience. Finally, sixth, the process included multiple disciplines and perspectives (Harte et al., 2017).

Aifaha et al. (2020) identified the health care industry as a fast-paced and competitive industry that required a methodology with rapid development cycles and identified HCD as an appropriate methodology in these settings. Preece and Reuschel (2014) found that developers of products in a health care setting were often more engaged with technical innovation than the usability of their products. Based on the need for a methodology that allows for more rapid design, Aifaha et al. (2020) identified three more requirements for an HCD research methodology to be successful. These were: that their design

process followed the six steps listed above; used design tools that allow rapid prototyping, testing and a development process; finally, that the methodology emphasised planning user testing and research sessions in advance to ensure a time-efficient process.

To allow for this research to follow both HCD and action research methodologies, after each stage of the research, I reflected on issues with each iteration of the product and used these to explore changes to the design process in subsequent stages of the research.

04.2. Research and Creative Methods

The Methods Used in the Research, Both Creative and Academic

Methods for the research were selected based on their applicability for action research and reflective human-centred design practice (Giacomin, 2015). The research was broken up into two action research cycles. This data was then analysed and investigated further using creative research methods and design tools to help create a basis of knowledge for ideation and solution generation (IDEO, 2015).

Methods of Investigation

Timeline Planning: Timeline-based planning is a tool used by many different disciplines to plan the stages of research (Gigante et al., 2017). Timeline planning formats the components of research in a timeframe and allows these components to evolve over time and build on previous components while remaining within predefined constraints (Gigante et al., 2017). In design, planning and timelines are an effective way to start to identify problems that may be faced in research prior to the problems occurring (Nadler, 1980). Nadler (1980) defined the importance of timeline planning to understand the past, present, and future of something. This helps not only to understand where a project has come from but where it might lead to in future.

My research used timelines as a method for planning throughout the duration of the research. Rather than creating a timeline to plan only at the start of the research, I used several timelines, which were updated and evolved throughout the research. These evolving timelines worked in tandem with the action research to allow the focus and direction of the research to evolve throughout the research duration. These timelines were made using computer-aided illustration programs (Adobe Illustrator) and were edited throughout the duration of the research.

Contextual Review: In traditional research, a literature review is often used to understand a topic before research occurs (Collins, 2010). Contextual reviews are similar in that they involve collecting, evaluating, and analysing existing knowledge to build an understanding of an area of knowledge (Barnes & Melles, 2007). The use of contextual reviews or literature reviews in creative design research has been debated due to the differences and similarities between the two methods. Griffith (2004) used a two-mode system to separate the differences between literature reviews and contextual reviews. In Griffith's system, literature reviews tended to focus more on the use of academically accepted work within a specific discipline, such as journal articles and books. Contextual reviews, in contrast, tend to use a 'messy' approach to secondary research, being cross-disciplinary and qualitative in nature.

Before research can begin understanding the contexts around a body of knowledge is imperative (Hempel, 2020). I decided to use a contextual review as I felt this was the most appropriate due to the cross-disciplinary nature of the research subject matter (Barnes & Melles, 2007).

The contextual review included in this research analysed both relevant literature and experiences from experts in the field of research (nurses, previous patients, and designers with experience in medical product design). Academic literature focused on prior research on OPIVA services, misuse of medical products, elastomeric infusion devices, human-centred design, participatory design, product design in health care and medical product development. Literature was sourced through recommendations from supervising academics, Google Scholar's online database of research and AUT's library. Literature was found using various search terms relating to the above topics. Relevant research literature was downloaded and read to find relevant information before I analysed and discussed the relevant contexts for this research. Along with this literature, consultations with stakeholders (an OPIVA

nurse, a previous patient, and a member of the Waitematā DHB's Innovation division, I3) occurred to provide experiences and insights which were not available in existing research. These consultations occurred through several Zoom calls in July 2020.

Expert Interviews: Expert interviews are a qualitative research method that involves conducting interviews with a person who is knowledgeable in a particular subject (Bogner et al., 2009). Interviews allow for a researcher to understand better the experiences of the participant in relation to specific contexts defined by the researcher (Van Audenhove & Donders, 2019). Semi-structured interviews involve research topics that allow for more causal discussion open-ended responses between the researcher and the participant (Louise Barriball & While, 1994). Interviews are a straightforward way to begin to create discussions and build a background of knowledge around an area of research.

Previous patient interview questions initially centred around the overall experiences of the participant as a patient in the OPIVA service in terms of changes to lifestyle and their experiences with the OPIVA staff and the hospital. Interviews with clinical staff discussed their experiences and roles as staff members supporting OPIVA patients. The first section of questions aimed to build up a context of the experiences of patients and staff in the OPIVA service. The second set of questions involved the patient and staff's experiences and opinions on the physical devices that made up the OPIVA system. These questions aimed to explore what changes the patients and staff would make to the OPIVA service itself (see Appendix A. for indicative interview topics). The interviews were audio-recorded and then transcribed following the conclusion of the interview. Each semi-structured interview took one hour in length, and three of the sessions took place at North Shore Hospital. One interview took place over the phone as the patient was unable to attend a research session at the hospital due to mobility limitations.

A summary of insights and reflections based on each interview was then written to use as a reference point during the subsequent stages of the research. This reflection was used as the basis for the conceptual analysis

of the research (see *Conceptualisation* below). Based on these interviews, I created a list of user requirements that influenced the exact questions and methods used in the later stages of the research to best meet the patient's needs in the research outcomes. The guidelines helped constrain the HCD aspects of the research process.

Research Probes: In design research, 'probes' are a participatory design-led approach used to produce responses from participants (Sanders & Stappers, 2014). Responses to probes can be used to influence the later stages of research and can inspire further design developments in the research (Wallace et al., 2013).

In this research, sketches and low fidelity prototypes were used as talking points in expert interviews with clinical staff and patient users. Their feedback helped me to brainstorm new ideas and highlight possible design opportunities. Their opinions and feedback influenced the direction and iterative stages of the creative process (McNiff, 2013).

Figure 15. Prototypes and sketches were used as research probes during expert critiques in the later stages of the research.



Participant Recruitment: Previous patient and clinical staff participants for the research were recruited via the existing Waitematā DHB OPIVA database, accessed by Waitematā DHB staff, of names listing people that currently provide or have recently finished treatment in the OPIVA service. If those approached by Waitematā DHB were happy to participate, they were provided with a contact for the researcher (either by e-mail or telephone). The researcher did not have access to patient's contacts unless they expressed an interest in participation. The Waitematā DHB was not aware of which patients/clinicians participated, so their care/employment would not be influenced. If participants wished to participate, they were able to indicate a mutually convenient time for an interview to occur. Written consent was obtained from the potential participants at the time of the interview or prior to the interview for those which occurred on the phone. Three previous patients and three clinical staff members were recruited and interviewed between November and December 2020. One previous patient was recruited and interviewed in February 2021.

Single Expert User Case Study: Often in HCD research, researchers will use users as case studies to explore the needs of users (Besnard & Bastien-Toniazzo, 1999). Although researchers can consider a wide range of participants, research can take place with fewer participants more intensively. This method of working closely with a few participants is known as a 'case study' (Gerring, 2007). Rasoulifar et al. (2008) advocated for the inclusion of an 'expert user' as a case study in the HCD process to improve the applicability of the research outcomes to that specific user group. They defined an 'expert user' as someone with specific knowledge of a research area (Rasoulifar et al., 2008, p. 420).

Alongside the other participants, a single user case study (expert user) was involved throughout the research. This user had previous design experience and was able to provide more direct feedback on concepts through all three expert critiques (see *Expert Critique* below). Prior to the start of the research, a previous patient of the OPIVA service approached the research team because of their own experiences of the OPIVA service and desire to help facilitate change within the service. As a result, they were recruited for the research outside the usual procedure described above. Written consent was obtained from the single expert user case study at the time of the first interview session with them.

This user was involved in four research sessions: first, a (one-hour long session in October 2020) semi-structured interview to explore their experiences with OPIVA from the beginning to the end of their treatment. This initial meeting acted as a context building session. Following this initial semi-structured interview with the single-user case study, they took part in three follow up expert critique sessions (thirty minutes long for each session, taking place in November 2020, January 2021, and March 2021).

Roleplaying: Roleplaying is a design method used to explore interactions with products to ensure that the designer understands and can empathise with the user experience. In roleplaying, the researcher assumes the role of someone to allow them to better empathise with that person (Boess, 2008). Roleplaying often uses props to aid imagination and performances while helping to remove the researcher from their everyday experiences (Diaz et al., 2009).

I used roleplaying as a method to help better understand the experiences of OPIVA patients through their treatment. With the assistance of one of the nurses who run the Waitemata DHB OPIVA service, I was able to experience an approximation of the first week of the OPIVA service, from the first meeting with a nurse where the patient was set up with their first Baxter infuser until the first dressing change. It was not possible (ethically) to simulate the pain and discomfort associated with inserting a PICC line intravenously. However, a PICC line was still cut and fixed to my arm in place of a functioning catheter. The remainder of the system was the same as a patient would have aside from using empty infusers to avoid antibiotic waste.

I wore the system for a week as advised by the OPIVA nurse as this was the maximum amount of time the dressings should stay on and would help me understand the daily infuser changes and adjustments to my day-to-day life that would be required in a longer timeframe. Roleplaying the OPIVA service outside the Hospital involved all the activities a normal OPIVA patient would experience. These included: plastic wrapping the dressing during showers to avoid getting the dressing wet; changing the infuser every 24 hours after the initial infuser was set up; managing the infuser and PICC line throughout the day and while sleeping. Although roleplaying was a useful tool for building empathy and understanding for the participants of the research, within this research, there were limitations to the applicability of the roleplaying. These included not being able to replicate the pain and discomfort caused by having

a PICC line in for 6-8 weeks and dealing with the anxiety and fear that infection risk can bring (Nicholson & Davies, 2013; Yap et al., 2006). The roleplay was documented through a daily diary, filled out at the time of the infuser changes to note any specific feelings or experiences I had during the day and then also to outline my experiences with the infuser changes specifically. I also took pictures of the system with both a camera and my phone to help provide visual references for my experiences with the treatment system.



Figure 16. The roleplay during the research occurred with a mock OPIVA system.

Methods for Understanding

Journey Mapping: Journey maps originated in service design (Stickdorn & Sneider, 2012). They are used to help a researcher explore the thoughts, feelings, and experiences of users as they travel through a service or system (Kimbell, 2014; Simonse et al., 2019; Stickdorn & Schneider, 2012). Journey maps, like timelines, are a visual tool to highlight experiences across a timeframe. Journey maps are often a generalised study of the typical emotions and events the average user of a product or service might experience during use (Howard, 2014).

I constructed two journey maps based on insights from the OPIVA clinical staff and previous patients, which explored the emotions and experiences of a patient travelling through their treatment in the OPIVA service. This method helped to illustrate and highlight the user's experiences. The first map focused on the macro experience of patients, such as the events that made up the whole 6–8-week period, while the other highlighted micro experiences such as the events and emotions that occurred during a single infuser change. These maps were initially produced with note-taking with the help of hospital staff and patients. These notes were later developed into digital illustrations to summarise and more effectively communicate patients' journey. These were then used along with sketches as probes in interviews with subsequent patients (see *research probes* and *expert interview* methods above).

Personas: Personas are used to better understand a user group by creating a generic fictitious representation of a specific user while maintaining empathy and understanding for the user (Adlin & Pruitt, 2006). Personas are often used to give context to other design methods like journey maps as they help provide information about a user group (Golden et al., 2011).

In my research, I created two personas based on the key OPIVA user groups: nurses and OPIVA patients. These personas were created to help characterise and make visible the variety of user needs. These personas were constructed from data gathered during the initial expert interviews with patients and clinical staff. Following their creation, each persona was used as a reference point for the evaluation of concepts and ideas without needing the direct input from the user group the persona represented.

Design Brief: A brief defines problems that need to be solved. Design briefs help to communicate the design opportunities and requirements for a successful solution (Dankl, 2013).

Using my initial secondary and primary research, I created a design brief to highlight the design opportunities within the research landscape. This design brief focused on a series of specifications including, manufacturing, aesthetics, and function/purpose. The design brief was used to take complex ideas and refine them down to a simple format that was easier to use as a reference document throughout my creative process. The first design brief I created was written early in my creative process, and to better meeting the development of the project, I created a second refined design brief later in the process. This document was adapted as my research developed (Swann, 2002; Sadowska & Laffy, 2017).

Conceptualisation: Conceptualisation is a method of analysing qualitative data by looking for patterns and similar themes in the data. Conceptualisation allows the researcher to construct themes from data and enable new themes and concepts to form and develop as the data is analysed (Neuman, 2014). These concepts can be adjusted and developed both during data gathering and analysis (Kipper, 2013).

In this research, the conceptual analysis (conceptualisation) took the form of a series of written reflections following each expert interview and each expert critique. These reflections were analysed and refined to find and highlight consistent concepts mentioned by participants. Similar concepts were then grouped to identify consistent themes across the interviews and highlight patterns. Each written reflection built on what previous participants had said and my own reflections on the participants' experiences to create an evolving conceptual analysis. This combination of participant's experiences and my own reflections created the conceptual analysis used to influence the design process. This analysis method aligned with an action research methodology as it allowed a flexible approach to the types of data included in the research. In the analysis of the research, themes that were subsequently created informed the creative research process.

Methods for Creation

Sketching for Ideation: In the creative research process, sketching is an effective way to ideate and communicate concepts and ideas through a visual medium (Hoffman, 2020). Sketches often evolve throughout the research process as a reflection of the stages of the research (Parsons, 2009). Sketching is often quicker to produce than other methods of ideation and can act as an effective communication method (Hoffman, 2020).

Throughout my research, I used sketching as a creative research method. Sketching helped to build on my understanding of the products and to explore aesthetic and function. Initially, I started with rough sketches to explore unrefined ideas. My initial unfamiliarity with the topic meant that sketches helped me to start exploring concepts and better understand not only the existing OPIVA products but also explore future solutions. As the research developed and I began to understand the research topic more fully, my sketches became more refined and focused on specific details or design elements with greater consideration for physical limitations (e.g. materiality and production methods).

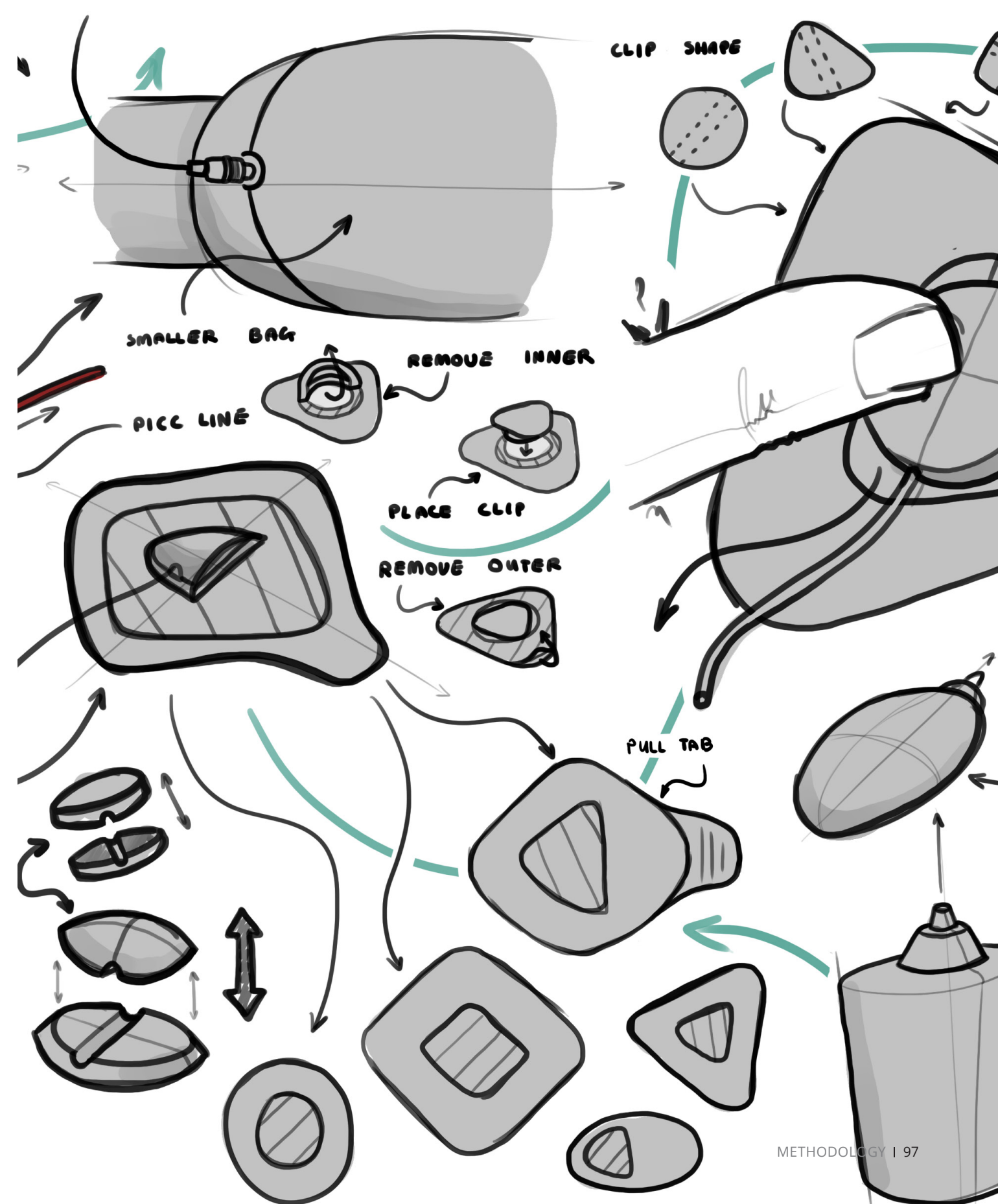
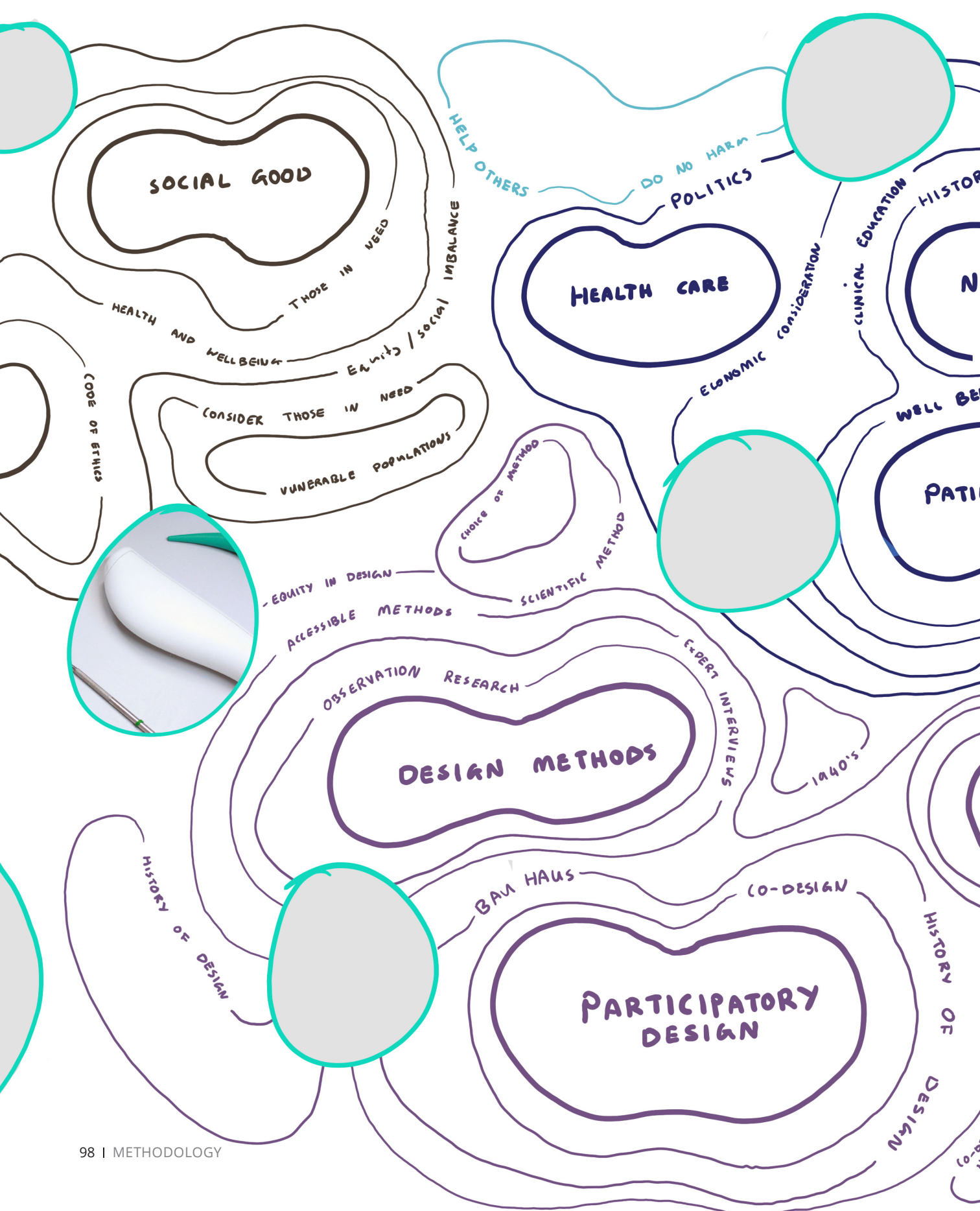


Figure 17. An example of sketch work to explore concepts and ideas.



Brainstorming: Brainstorming is a creative method that allows for ideas to be rapidly created relating to a central idea or theme. Generally, brainstorming can focus on presenting concepts that aim to solve problems through using both written and visual formats (Parsons, 2009; Wilson, 2013).

Initially, brainstorming was used to explore potential research topics. This helped me to plan out search terms for use in literature reviews. Later in the research, brainstorming was used as a method to reflect on existing literature to explore possible design opportunities for the research. This included what design solutions could be without being restricted by needing to 'make' ideas (e.g. sketching or prototyping). Ideas from brainstorming were then transferred to post-it notes, which were evaluated based on feasibility and possibility for success based on assumptions by the researcher.

Figure 18. An example of brainstorming used in the research.

Prototyping: Prototyping, like sketching, is used as a method to help explore concepts and ideas into a more easily communicable medium (Vaughan, 2017; Parsons, 2009). Unlike sketching, however, prototyping gives concepts 3D form. This provides a basis for user testing and exploration of form and scale. Prototyping is an effective research method to understand ideas. However, to help end-users achieve an even better understanding of each concept for end-users, prototypes can be combined with interviews, providing effective user feedback, especially in the realm of ergonomics, human factors, and usability (Liem, 2019).

Through my research, I started with low-fidelity prototypes using cost-effective materials such as cardboard and extruded foam. These prototypes helped me to explore the size and ergonomics of my concepts along with functional aspects that were more difficult to achieve through sketches. As I progressed through the research, I started to use computer-aided design (CAD) and additive manufacturing (3D printing) to explore more refined prototypes. These were used to help me explore the function of specific elements related to design and manufacturing considerations. Materials were selected to best represent what might be used in manufacturing, for example, vinyl tubing (to mimic IV lines) and store-bought adhesive dressings (to mimic professionally supplied dressings). A high-fidelity final prototype was produced to communicate the outcome of the research to highlight the experiences and improvements for the OPIVA service as desired by the patients within the service. Final prototypes were materially and functionally as accurate as possible to help ensure stakeholders understood the proposed functions and aesthetics.

Figure 19. Low fidelity prototype examples.



Mood boards: Mood boards are a visual research method that allows for the researcher to collect photographs and images that can be grouped together to communicate style trends and aesthetics and used to inform the direction for future designs (Garner, & McDonagh-Philp, 2001). Mood boards are a research tool but can also act as a communication method to help show design directions along with the colour scheme, material choice, form, and textures informing a creative process (Freeman et al., 2017).

In this research, mood boards were used to explore possible product aesthetics and to inform my design practice. I used online search engines such as Google.com, Instagram.com and Pinterest.com to find images relating to search topics such as “medical design”, “non-threatening product design”, “health-care design”, “product design in health-care”, “wearable medical design”, “minimalist product design”, “contemporary product design”, elegant product design” and “calming product design”. These images were used to influence the form language and aesthetic trends, which were included in my ideation and exploration. These search terms were chosen based on secondary research and existing patient preferences of aesthetics in healthcare design (Townsend & Sood, 2012; Sansoni et al., 2014; Watts et al., 2015).

Computer-Aided Design (CAD): Computer-aided design (CAD) is a design method where computer software is used to aid in the construction of 3D models (Bi & Wang, 2020; Parsons, 2009).

In this research, I used the computer software SolidWorks to produce files for use in both digitally rendered images and for 3D printing. Initially, I used CAD models to explore simple form language quickly and then, later, to produce accurate models for fabrication and prototyping. CAD allowed me to explore concepts more quickly and in higher levels of refinement than I would have been able to produce through handmade methods. The final CAD models created in the research were designed to be as close to production quality as possible with correct dimensioning and manufacturing considerations.

Methods for Reflection

Evaluation Matrices: One limitation of the research was the low number of participants. To avoid burdening participants with too many concept feedback sessions, I decided to use evaluation matrices as a method for evaluating concepts before taking them to participants for feedback. I created matrices that featured the most successful concepts from my ideation and rated them based on the criteria established as part of the design brief (Stevanovic et al., 2015). This allowed me to identify what concepts were successful without requiring input from users between expert critique sessions. If multiple concepts rated highly, these would be developed further separately or combined to form a final direction.

Expert Critiques: Like an expert interview, expert critiques act as a method of gaining expert opinions on final concepts and design solutions. Expert critiques are research sessions that focus on expert end-users providing direct feedback on a system or product (Gray, 2018; Hägglund, 1993).

During the first expert critique phase, a single session took place with the single expert user. This session helped to provide feedback on several sketches and low fidelity prototypes. This session was used to shift the focus of the research from that of two separate design directions (non-medical aesthetic and ease of use focused) towards a single design direction. The second phase of expert critique sessions involved presenting two concepts (a sketch and a prototype of each concept) in each area (infuser, IV management system, infuser storage) to a previous OPIVA patient, the single expert user and an OPIVA nurse. Questions were centred around their opinions of the designs, both on the assumed function and aesthetic of designs. The final expert critique only had one session with the single expert user. This session was used to finalise and providing feedback on the function and aesthetic of the early final prototypes. Each provided a point to gather user feedback on my concepts and help inform the next stages of the design process. All expert critique sessions took approximately thirty minutes to complete. Expert critique sessions with the previous patient and OPIVA nurse (during phase two) took place at North Shore Hospital. All three expert critique sessions with the single-user case study took place at AUT's city campus.

Reflective Practice: Reflection is an important part of the action research process. In action research, it is important to reflect on each stage of the research and use these reflections to build upon research and influence later stages (Lawson, 2005). Reflective practice is an effective method to avoid the research process becoming overly linear, which can lead to objectives and aims set early in the research process being forgotten (McNiff, 2017). By regularly reflecting on the research, each stage can be separated effectively and used to build off each other in the cyclic fashion that action research uses.

Throughout my research, I wrote reflections on each stage of the creative process. This allowed me to consider and reflect upon what worked and what did not, along with exploring what future steps could be taken to improve the subsequent stages of the design process. These were used to reflect the conceptual analysis that took place during the expert interviews and ensure the research was maintaining its HCD focus and exploring solutions that could adequately meet users' needs.

04.3. Ethical Considerations

The Ethical Dimensions Which Influenced the Research

For research to be successful, HCD requires the engagement and participation of people (as users) (Giacomin, 2015). A range of participant groups was needed in this research to provide contextual information with respect to user needs and experiences and to provide feedback on concepts and solutions in the later stages of the research. Experiences from both OPIVA patients and clinicians involved with the OPIVA service were represented in the research to ensure research design outcomes would best reflect the experiences of those involved with the OPIVA service. Research that includes participants has the potential to impact them negatively. Therefore, the research methods I selected were considered through an ethical lens to help ensure participants were protected and treated with respect and dignity during all stages of the research (Gregory, 2003).

I approached one of the nurses who was involved with the OPIVA service within the Waitematā DHB to gain their insights into how best to conduct research with the OPIVA clinical staff and patients. The nurse gave feedback on the planned research and provided information on how best to approach potential participants. I3 (an innovation team within the Waitematā DHB) was suggested as a group that could act on my behalf in the research, contacting patients and clinicians to ensure they were protected and had their confidentiality maintained. Initially, the research plan had intended to include the experiences of the OPIVA nurses, OPIVA pharmacists, infectious disease doctors, DNs, and OPIVA patients themselves. However, no DNs expressed interest in

participating in the research.

Part of the ethics process was ensuring that the research provided some benefit for participants. For the OPIVA nursing team and the Waitematā DHB, the key benefit from the research was to allow them to understand better their patient's experiences and where improvements could be made. The OPIVA nurses surveyed patients following their treatment, but this had limitations around the level of detail patients could achieve with their responses. Aside from this survey, the clinical staff received little feedback from patients following the conclusion of their treatment (Personal Communication Nurse Expert Interview, November 30).

OPIVA patients treated through the Waitematā DHB were all adults, meaning that they were able to give informed consent, an important ethical dimension of research (Wertheimer, 1999). However, during treatment, OPIVA patients experienced many symptoms associated with the recovery from their infection. These include, but were not limited to, elevated heart rate, fatigue, fever, neurological symptoms (such as confusion) and nausea (Lever & Mackenzie, 2007). As a result, patients currently in the OPIVA service were considered a vulnerable population (Flaskerud, 1998). As well as this, there were possible confidentiality issues with the patient's remaining treatment had they still been in the service. Because of this, patients were approached following the conclusion of their treatment. Contacting patients following their treatment also ensured the researchers did not know how was currently receiving treatment in the service to ensure confidentiality. Invitations were provided by a staff member of the Waitematā DHB. Through the period of September 2020 to April 2021, 31 previous patients were invited to participate, and of those, four were interested in participating. Along with these four patients, three clinical staff members participated in the research and one expert case study user. All participants were over 18 years of age.

In accordance with AUT's Ethics Committee (AUTEC), a detailed ethics proposal was submitted outlining the research and detailing how ethical considerations had played a role in the design of the research (Appendix H.). An ethics consultation occurred with one previous OPIVA patient, an OPIVA nurse and a Waitematā DHB pharmacist to support this document.

AUTEC approval was granted 6/10/2020 (Ethics Number 20/293)

05. Research Documentation

05.1. Context Building

Understanding the Research Using Primary Research Methods

Expert Interview // Clinical Staff

To start the context building process, I used expert interviews. A single interview occurred with each of the main clinical OPIVA user groups (an OPIVA nurse, a pharmacist, and a doctor). Each clinical staff member made up a different part of the system, each having a distinct role. For example, within the Waitemata DHB, two nurse specialists ran the entire OPIVA service. They set patients up with their first infuser before they were discharged and followed up with any patient questions once they were at home. The pressure of this management was highlighted throughout our interview; the OPIVA nurse had to answer several texts and phone calls to patients with questions and concerns. In addition, three infectious disease doctors were involved with the oversight of patient care (including inpatient and outpatient care). These doctors were more focused on the overall care for the patient's treatment rather than specifically the OPIVA service. Finally, the hospital pharmacists were on a rotating schedule through the OPIVA service. As a result, pharmacists had the least interactions with patients. Instead, their role in the service was centred on arranging shipments of infusers to be sent to patients.

Each member of the clinical staff team had concerns about mistakes that could occur with the misuse of the system while patients were at home. Patients in the OPIVA service would spend much of their time alone, and this could lead to accidents occurring. These included accidentally unthreading the positive

pressure valve from the IV extension or even wrapping the infuser around a bedpost, forgetting, and pulling the PICC line out of their arm. The OPIVA nurse highlighted the importance of explaining the use of the system to avoid such adverse events. The clinical staff's perspectives on the physical elements of the service were more focused on functional issues than the user experience. These included:

Although the staff all wanted to improve the patients' experiences, none were aware that other brands of elastomeric infusers existed, despite literature suggesting other brands could already improve the patient experiences' (Dodd, 2007).

OPIVA Roleplay

Along with gathering the experiences of OPIVA patients, another element of my creative research process was roleplaying. This research method allowed me to better understand the actual experiences of the patients within the OPIVA service. With the help of an OPIVA nurse, I roleplayed the OPIVA set-up process, then I went home and spent a week with a mock OPIVA treatment system. I was shown the Baxter infuser and explained what it was and how it would work. Both A full and empty infuser was shown to me to ensure I would only change the infuser once the infusion was complete. The infuser was meant to infuse the antibiotics (240ml) over 24 hours, but this can vary by around 10%. The OPIVA nurse then thoroughly explained the service, including when the DNs would visit the patient at home. I was then given a booklet that outlined the service and infuser change guidelines. When the first Baxter infuser was set up, the nurse ran me through the process. The patient would already have a PICC line inserted in their arm, PICC line stabilizer and sterile dressing at this point. The nurse showed me the infuser and fitted the IV extension line to the (mock) PICC line, then the infuser to that. Each IV connector was cleaned with alcohol wipes for twenty seconds to ensure minimal risk of infection. Prior to the infuser being fitted, the IV line was flushed with saline to ensure no occlusions were present in the IV lines. The infuser IV line and flow restrictor were then taped to my upper arm to ensure no kinks occur, and a tubular bandage was cut to length and fitted over the elbow and upper arm to protect the system. This demonstration provided an explanation for the procedure that a patient would follow each day from home.

The method of changing the infuser within the OPIVA service involved several steps. The first was to clean the patient's hands using anti-microbial wash, then the laminated infuser change guide sheet was cleaned with another anti-microbial wash (patients were expected to purchase their own bottle of

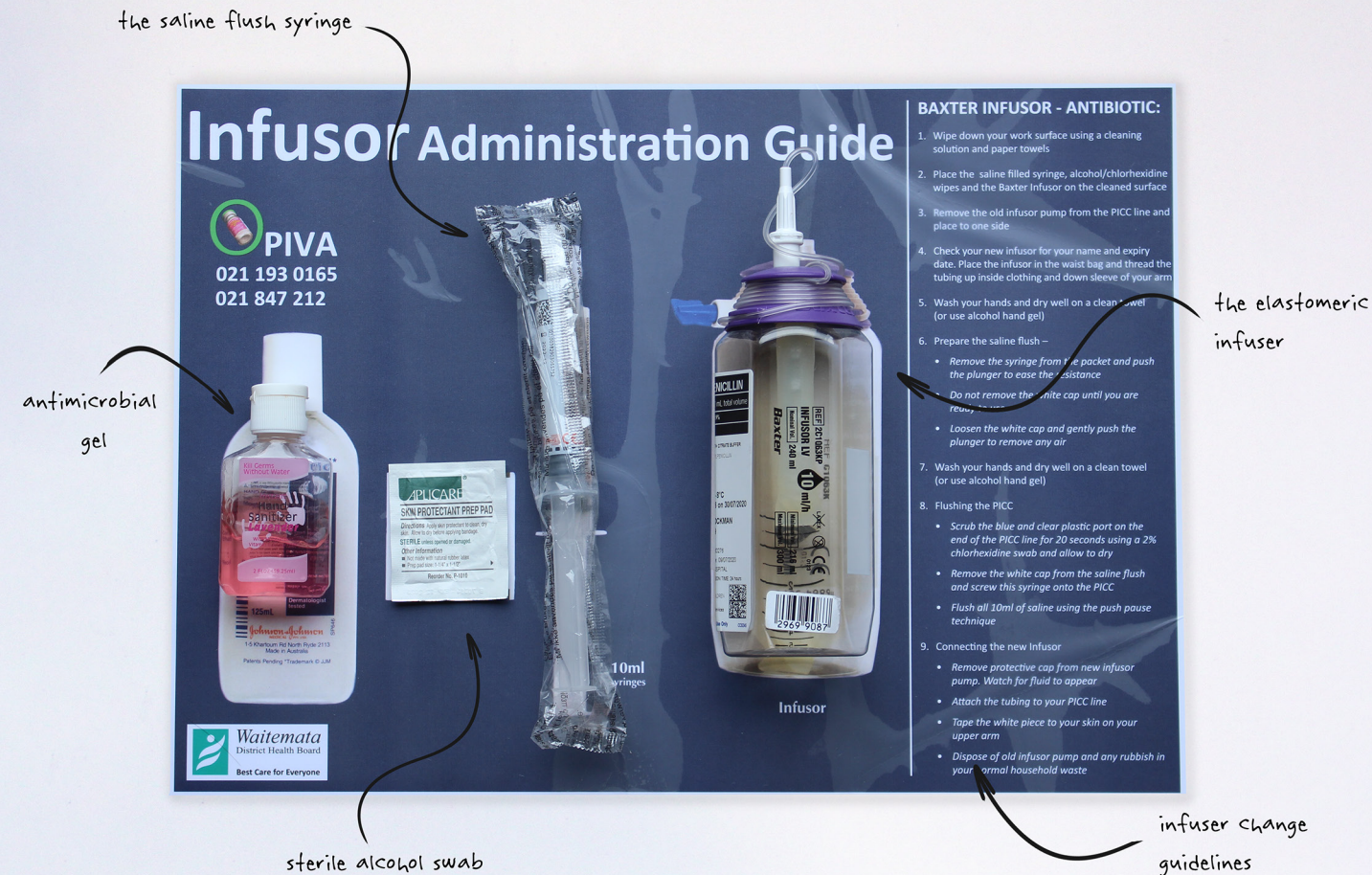


Figure 20. All the elements of the OPIVA service prepared for an infuser change.

anti-microbial wash to use). The required parts for changing the infuser were then laid out on this sheet. These included: the new infuser, several alcohol swabs, and a saline flush. The old infuser was removed from the IV line, and the connector then cleaned with one of the alcohol swabs. Next, the IV line was flushed with the saline syringe to ensure that any blockages in the PICC line were removed (occlusions). The new infuser was then uncapped (the cap removed from the flow restrictor) and checked to ensure there was antibiotic flow through a drip test. Drip testing the infuser involved ensuring the flow of antibiotics by checking to see if a drop of the drug formed in the flow restrictor outlet.

The new infuser was then fitted to the IV line. After a couple of hours, the infusion balloon needed to be visually checked against the infusion rate indicator on the infusion shell to ensure no IV line or PICC line blockages had occurred. If a blockage had occurred, the patient would need to check the IV lines for kinks that could cause blockages, and if these were not an issue, flush the blockage using another saline flush and fit a new infuser. If the patient could not flush the IV line (as can happen if an occlusion occurs in the PICC line), then they would need to go to the hospital to either have the occlusion cleared or have a new PICC line fitted.

Reflections on General Care: Because the system was not real, it was difficult to fully appreciate concerns around the anxieties that could be present if I had been in the real OPIVA service. The dressing was slightly itchy and annoying to wear, and I was concerned that the infusion line would be bent or positioned wrong for the infuser to work correctly. Holding the IV line still while fitting the tape each day was a challenge as I could only use one hand to do both. In this roleplay, the PICC line was not inserted into my arm; instead, it was coiled on my bicep. The infuser changes took me an average of 15 minutes each day. As I became more familiar with the process, I had to be careful not to rush it and



Figure 21. An example of the drip test on the infuser flow restrictor.

Image removed for copyright reasons.

<https://www.flickr.com/photos/alchristensen/6252983164/in/album-72157627794173161/>

Figure 22. Christensen, (2011). An example of a saline flush on a PICC line. Saline flushes were used to ensure the IV lines were clear of obstructions.

miss any steps. This issue would be even more important if infection risk were an issue for me.

Use in public: Although I felt comfortable with the system and the medical sides of the treatment, it was strange being in public with a visible medical product. I have experience with medical devices in inpatient care; however, I have never managed them while in a public space. I wore the waist bag on the outside of my clothing and had the tubular bandage covering the dressing visible under a t-shirt. Because of existing trends in fashion, I felt strange using a ‘bum bag’ in public, even if used in a medical treatment context.

Sleeping: I had anticipated sleeping to be uncomfortable with additions of the infuser and IV lines. The infuser needed to be kept in the insulated storage bag and placed on a bedside table. I needed to take care not to roll over onto the IV line during the night. Rolling the wrong way could stop the flow or could risk pulling out the PICC line. I had anticipated this to be quite challenging; however, it was not as difficult as I expected. Having the OPIVA system with me while I slept did not impact my sleep, and I could sleep comfortably. Several of the comments made by the patients’ participants were confirmed in my experiences, mainly that it would have been better to have not had the uncomfortable IV-line connectors on my arm, which, if lying on my side, caused discomfort in my arm.



Figure 23. I was able to keep my infuser in its bag on my bedside table, which meant that my sleeping was largely unaffected.

Overall reflection: My experience with the OPIVA treatment system was frustrating and more time consuming than I had initially anticipated. However, within a couple of days, I started to get into a routine. Although this routine was somewhat of a relief, I began to make more mistakes once I started getting comfortable, and I was occasionally clumsy when handling the infuser. I dropped the infuser once during a mock infuser change. I was lucky as I was in a carpeted room. I tried to make sure I was always particular with wiping the connection points to ensure no infection risk; however, it became hard to remember to sterilize for the correct length of time. Although a laminated guide sheet was provided to guide/support patients through the process, I found myself not following the guide to the letter. In addition, most of the instructions were written in very small font. A more visually clear infuser changing surface could be an improvement. Living even part of the patient's experience was eye-opening and made me realise just how all-consuming the OPIVA treatment system was. Although my experience only lasted a week, I found myself more worried about my next infuser change or how people looked at me than just about anything else in my life at the time.

05.2. Discovery Through Ideation

Exploration of Assumptions and Discovery of Design Opportunities Through Ideation

To start the creative research process, I went through several concept ideation cycles. These cycles were primarily focused on exploring unrefined concepts to help me familiarise myself with the devices and parts of the system and where design opportunities may arise. By using concepts and prototyping as a rapid form of idea generation, I started to explore possible design-based solutions that improved upon areas that participants highlighted during their interviews. This ideation helped me give form to the assumptions I had around the OPIVA service based on my initial interviews and role play.

Mood board images removed for copyright reasons.

Figure 24. Aesthetically pleasing medical devices mood board. The starting point for ideation in the research was to collect some examples of medical products which had been designed with aesthetics which I found interesting and I felt could be applied to the products I was designing.



Figure 25. I decided to use sketching as a form of creative discovery during the early stages of the design process. By using rapid sketching, I considered drastic changes to the system, such as using a backpack to store the infuser or creating an adhesive infuser. Based on these sketches, I then engaged in exploratory model making to refine these ideas further.

Figure 26. Once I had finished sketching, I started making simple cardboard models. These models helped me to begin categorising and highlighting the designs which I felt had the potential for further development. Through these models, I found that using a simple clip mounted to an adhesive patch was a particularly effective way to manage the IV lines. Other areas were disregarded, such as splitting the infuser into multiple parts, as I felt these added too much complexity to an already complex system. A more specific breakdown of individual prototypes and sketches is available in Appendix B.



05.3. Understanding the Patient

Context Building Interviews with Patients and Reflections Based on These

Expert Interview // Single OPIVA User Case Study

The expert user had already done a significant amount of thinking about the OPIVA service and system during their treatment. They were quickly able to communicate their experiences and point out the apparent issues they experienced. Overall, this participant's experiences within the OPIVA service were positive. They referred to the interpersonal communication between themselves and the clinical staff as a highlight during their treatment. Unlike the other patient participants in this research, this participant returned to work during their treatment, making infuser changes difficult. The user had to change the infuser and manage the IV taping in their car during the workday. Changing the infusers in their car meant balancing the provided laminated sheet on their lap and ensuring the system was sterile while replacing the infuser (the new infuser was kept in a cold bag during the day). Anxiety was primarily centred on the risks of blockages in the IV line. They were also concerned about the changes in personal attire that the system required. The user would typically wear 'modest' long sleeve clothing, but this was difficult when doing infuser changes. For the user to easily conduct infuser changes, they had to wear short-sleeved tops, which made them feel uncomfortable in the workplace. This discomfort was largely a result of the user having to expose the medical elements of the system when in public, along with the change to their usual work attire. The participant's concern around managing the system

in public was exacerbated as they were often concerned about people seeing them changing their infuser while in their car.

Critical areas for improvement that the user noted were:

- The taping system was frustrating and difficult to use. Applying and removing tape with only one hand was challenging and often would not provide a secure fit on the IV lines leading to the tape coming off. The user expressed that the OPIVA system would have been greatly improved with a system to replace or simplify the tape.
- The user disliked the style and colour of the waist bag used to store the infuser and was frustrated that there were no options for different storage solutions.
- A tube bandage was used to protect the PICC line, and the user found this tended to roll down and was another point of frustration.
- The sheet given to explain the system was confusing and complicated.
- Sustainability issues. The user was left to dispose of the infusers along with the weekly packaging from Baxter. The infuser was intended to be placed in a shower bag around the showerhead during showering. However, the user used showered in a different orientation to what was intended, and they found the system did not accommodate this.

The user took rough notes throughout their treatment:

- "The OPIVA nurse was very clear when explaining pitfalls / very direct and

very accessible should I need her."

- "First few days with infuser change sheet with instruction a little confusing- could be more clearly laid out on notes. Scale of image could be smaller and info could be bigger and coloured differently for each step."
- "District nurses varied in their approach. Allowed me to relax slightly with the variation in approach Used for the first two days at home."
- "Packaging huge wish that it could recycled and glad wrap city."
- "Kinks in line. Taping the kinks out. Tape, tape, tape."
- "Showering hanging device."
- "PICC line measuring could be improved."
- "Sock curl (tubular bandage)."

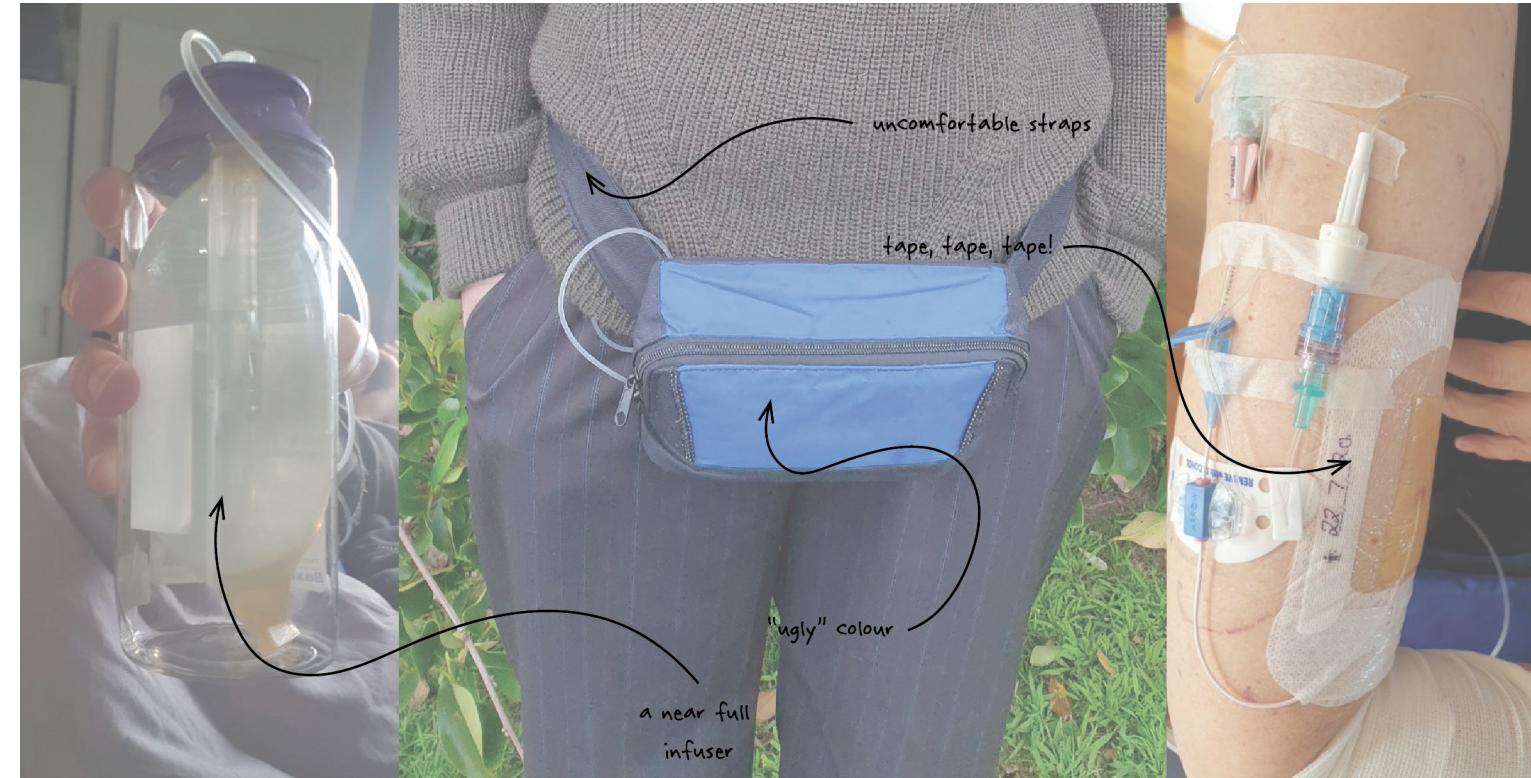


Figure 27. The user took photos of some of the key issues they faced during their treatment.

Participants Interviews // Previous OPIVA Patients

Four patient participants were interviewed for this research (excluding the expert user). Although each participant had a different perspective on the OPIVA service, several themes and areas were commonly highlighted by participants. Participants expressed issues with the usability of the existing taping system. Managing the tape was identified by all users as especially time-consuming because the tape had to be applied to the upper arm.

“The tape would come off, and even the butterfly (PICC stabilization point) broke at one point. The clip came off that, and I could not fix it without help.” – Patient participant four

“If the dressing and taping could be one part that would be changed during each dressing change, that would have been very helpful.” – Patient participant two.

Patients had to use one hand to hold the IV line and tape it in place simultaneously. Managing the tape was especially difficult for two participants who had limited mobility/dexterity. One of these participants was only able to use one arm and could not change the infusers themselves. The other participant had arthritis and was unable to manage the tape as peeling tape on and off their skin was too difficult.

“I have arthritis, and getting the tape off or using the knobs was hard. They were so small it was difficult. I had to have a district nurse do it each day.” Patient participant one.

The taping could be removed entirely if the change connection point could have been placed on the infuser itself. However, the flow restrictor had to be kept taped to the skin. The taping system was identified by the participants as an area that could be simplified and this would have a positive impact on their experiences. Two participants also highlighted that the taping had to be removed and moved to avoid skin abrasions from the IV line being kept in one place for too long.

The final common concern highlighted by participants was the bulk and size of both the Baxter infuser and the waist bag. The size of the bag meant that it needed to be worn above the clothing, and the canvas construction used was uncomfortable when in skin contact. In both existing literature and my research, patients found the Baxter infuser bulky and challenging to manage due to its hard shell and cumbersome shape (Dodd, 2007; Kumari et al., 2018). Participants felt that it would have been of significant benefit if the infuser could have been worn under their clothing. Being able to wear the infuser under clothing would have meant that the patients would not have to feel self-conscious about wearing the waist bag in public.

Another concern mentioned by participants was the amount of waste created by the OPIVA service. Three participants also experienced difficulties with the printed information (communication design aspects) provided.

Although several common themes were able to be constructed from the patient participants data, participants actually had very different experiences with the OPIVA service. For example, the expert user participant returned to work during their treatment, while three of the other participants required the support of a DN or family member throughout their entire treatment. The diversity of experiences surprised me as I had expected the participants to all have similar perspectives on the service. For one participant, the different

styles of care provided by the DNs were positive for their treatment as it allowed them to relax more as they came to realise that the treatment system could be flexible. In contrast, another patient cited the difference in care styles of the DNs as a source of anxiety for them. This diversity of opinions was also highlighted in the communication material provided to patients (the OPIVA guidelines booklet and infuser change laminated sheet). Some patients felt these could be improved on with smaller images or less difficult to read text, while others preferred the more image-focused sheet and did not mind the small text. Due to these differences of opinion, I decided to centre my focus in the research on improving the usability of three key products which all participants mentioned as causing difficulty with use during their treatment:

- ***The infuser***
- ***The taping system***
- ***The infuser storage bag***

Persona: Registered Nurse

Name: Stephanie Johnson

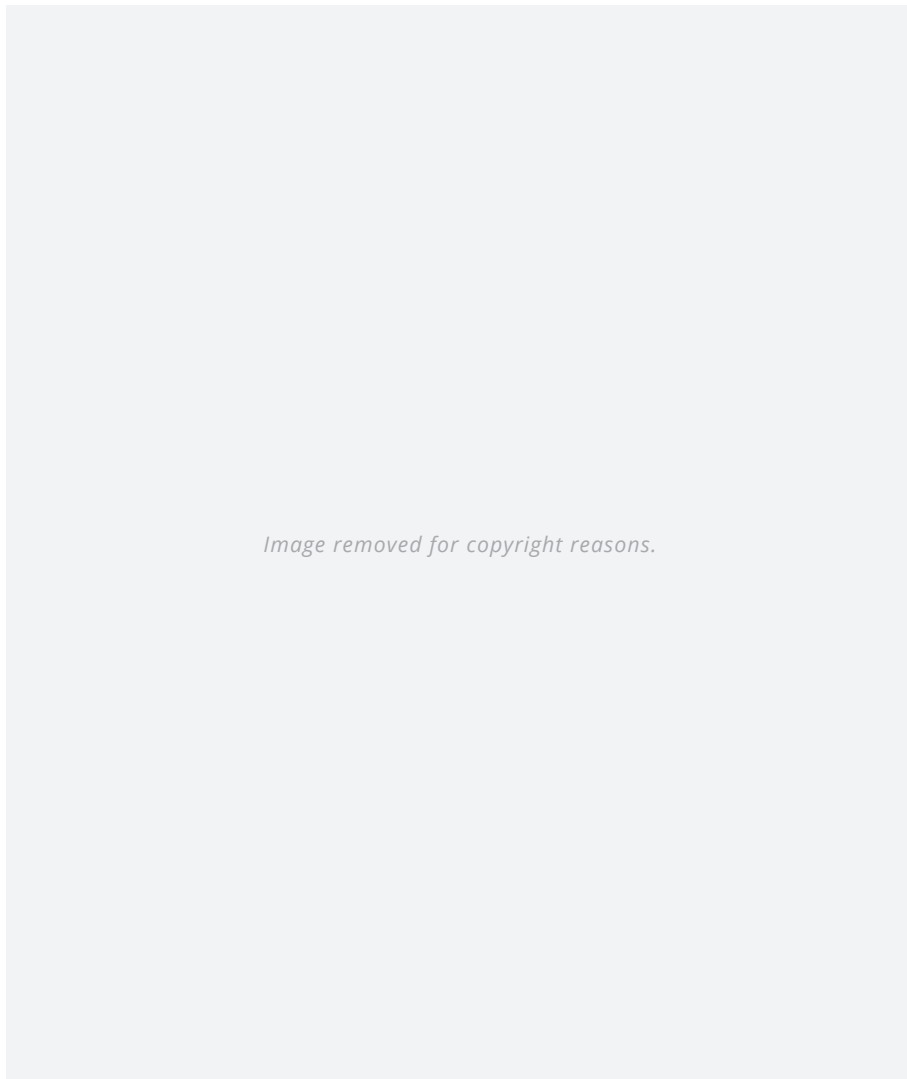
Age: 32

Occupation: Registered Nurse

Stephanie is a full time nurse working in a public hospital. She has several years of experience working with the standard instruments used in her practice and is used to working with patients and treating many different illnesses. She, however, sometimes struggles to provide effective treatment when it comes to less common procedures such as providing OPIVA (insertion and caring for a PICC line and antibiotics) the complex dressings and risk of infection lead to a slow and cumbersome procedure.

Image removed for copyright reasons.

Figure 28. Based on my initial research with the OPIVA nurses and staff, I constructed a persona of a nurse who could be involved with the OPIVA service. Using personas helped to define the user's needs.



Persona: OPIVA Patient

Name: Chis Hill

Age: 46

Occupation: Tradesperson

During his young adulthood Chris was diagnosed with HIV. Although HIV and AIDS can be managed with medication, in later life Chris has struggled to keep on top of the infections which often cause him so many issues.

As a solution for one particularly hard infection, Chris was offered OPIVA, outpatient intravenous antibiotics. Although he would have like to avoid such an extreme treatment, his need for long term (2-6 weeks) of corrosive antibiotic treatment required an insertion of a central line (PICC line). To avoid an extended stay in hospital this was altered to allow for home based antibiotic infusion.

During the PICC line insertion Chris was frustrated with the pain and discomfort caused by the insertion, which was exasbiated by the extended period of time insertion took. He also became nervous after discovering that the dressings would need regular changing and risk of infection was high and very dangerous.

Although he is comfortable living with a central venous catheter it has been a long process.

Figure 29. Patient persona. The patient persona took the needs from the interviews with patient participants and highlighted specific, common issues.

05.4. Initial Design Brief

Context Building Interviews with Patients and Reflections Based on These

A Design Brief to Outline the Goals of the First Stages of the Design Process

Once I had a better understanding of the issues that patients faced through the collection of primary research, I refined my creative process into two specific design directions. I formed these into a design brief to help guide the subsequent steps of the design process. I decided to focus more directly on ease of use and aesthetic. These design directions were defined as:

1. The first design featured a more traditional medical approach to aesthetics and focused on exploring ease of use. To achieve an easier to use system, I explored designs that could remove the need for tape to hold the IV in place. This system needed to be waterproof and easy to remove. The PICC line needed to be easy to keep in place and indicate if migration occurred during dressing changes. Finally, the IV infuser and storage system for the infuser was re-designed to favour ease of use and comfort during IV changes and day to day activities.
2. The second version of the OPIVA re-design aimed to remove the system's existing 'medical' aesthetic. The infuser was designed to appear, unlike a medical device. Infuser storage solutions were designed to either look like products not traditionally used in a medical setting or easily worn under clothing. Both sleeve-based systems and dressings were explored to protect and hide the PICC line and IV lines.

In addition, the following were considered:

- *Ergonomics* – how would users interact with the devices? Was it comfortable for the user?
- *End-User Experience* – was the device easy to use and intuitive?
- *Aesthetics* – how can contemporary aesthetics and elegance feature in medical product design?

To ensure all stakeholder needs were met, parts had to be cost-effective to manufacture or easily sterilisable. Along with clinician needs, the devices needed to be emotionally sensitive to anxious patients who may not have prior experience with medical treatments like OPIVA. Managing infection risk and conducting treatment at home can be daunting for many people (Poonam et al., 2018; Alpenberg et al., 2015). Therefore, providing a design that was non-threatening, comfortable, and easy to use was crucial to the success of this product.

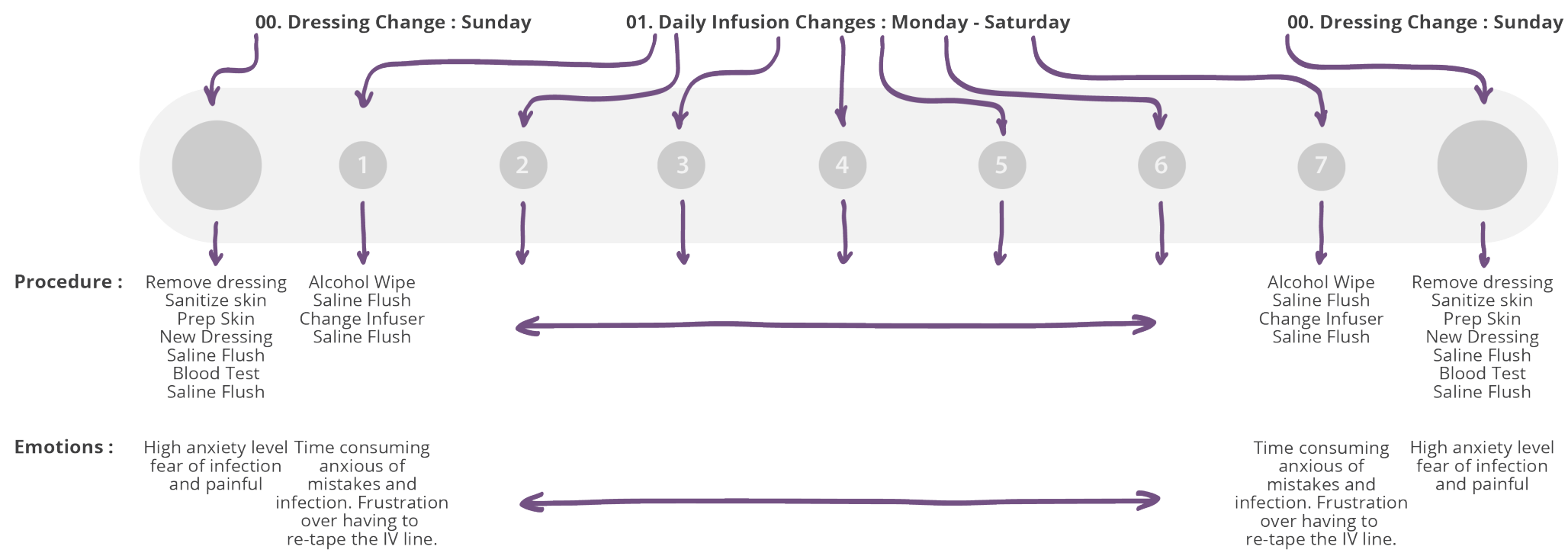
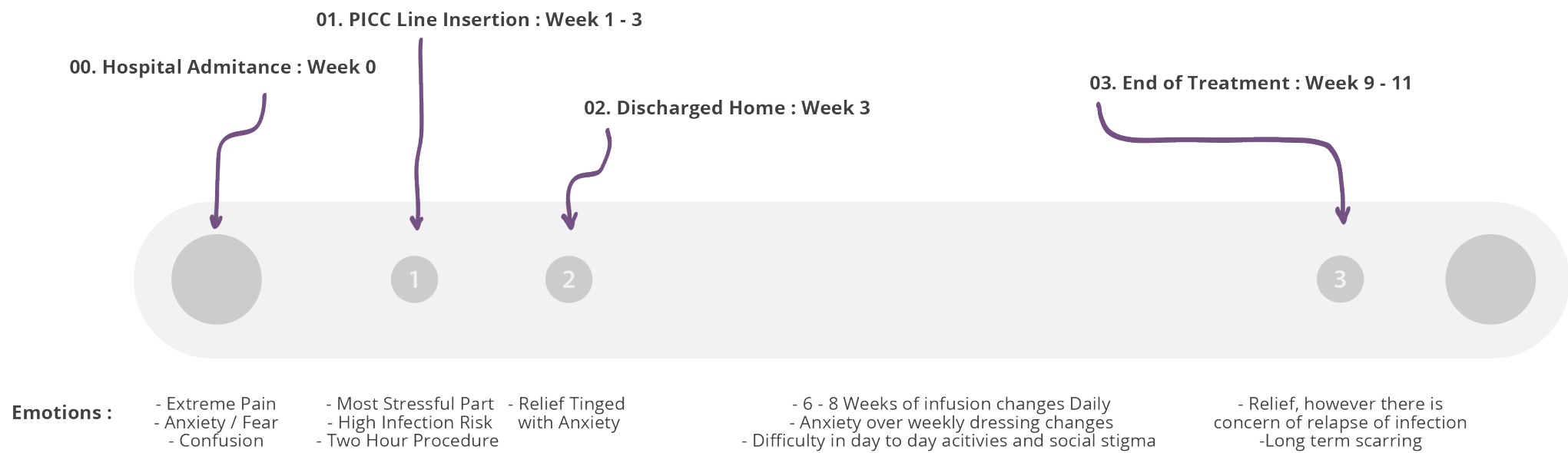


Figure 30. Two user experience road maps. OPIVA treatment road map from hospital admittance or end of treatment. A week of treatment, OPIVA patient journey map.

05.5. Ideation

The First Stages of Product Ideation

By interviewing patients and clinical staff, I was able to understand better the journey that patients in the OPIVA service would travel through during their treatment. Using journey maps, I was able to break down the individual experiences that make up a typical patient's treatment, from the daily infuser changes to the major events that occurred during the six to eight weeks of treatment. By breaking these events down, I could identify events and highlight the emotions that occurred at each point and identify where design intervention could benefit the patients. For example, although the PICC line insertion was a very anxiety-inducing experience, for most patients, this would only occur once. There was, however, the risk of infection and frustration with the infuser changes daily. Therefore, I decided to focus more on these regular/ everyday experiences rather than one-off experiences to improve the patient's experience in the service.

A Two Directional Approach to Ideation

Following the initial primary research undertaken with users and clinicians, I decided to explore two different directions to improve the OPIVA treatment system: usability focused and aesthetically focused. These two directions were selected to focus on two significant elements of designing a product (use and aesthetics) in separation from each other. Along with these sketches, I also explored how the infuser could be placed on the body. These sketches have been included in Appendix C.

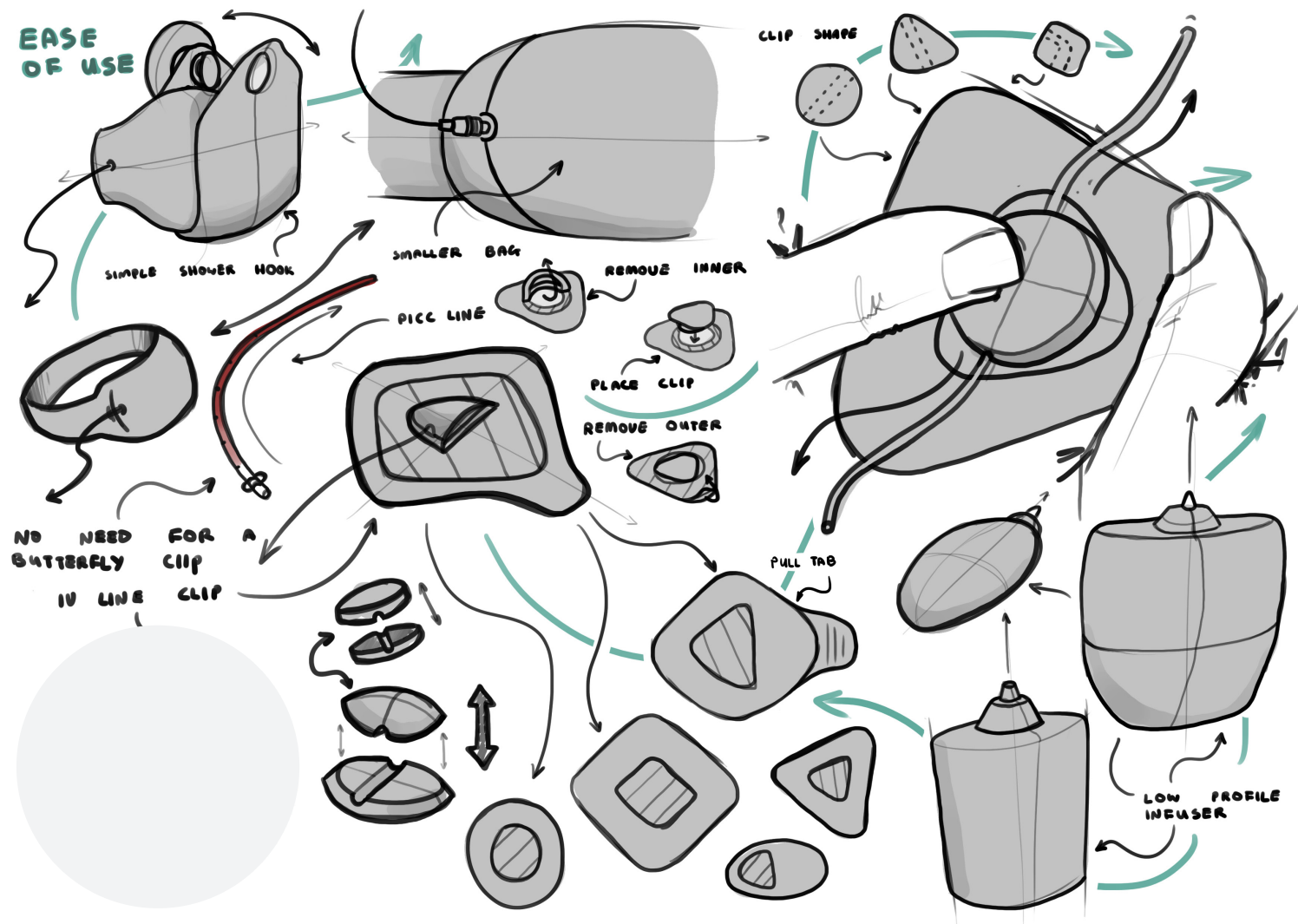


Figure 31. Initial usability focused exploration sketches.

A Two Directional Approach to Ideation

The subtle improvements focused on the main parts of the system; a low profile and easy to use IV storage bag, an IV-line clip/stabilization system and a more robust and sustainable IV infuser. In addition, several other parts were explored through these sketches, such as the PICC line and shower storage solutions.

Digital sketches were used to explore subtle changes and improvements to the system (Figure 31.). Based on my understanding of the research and assumptions, the inclusion of an IV infuser shower storage system that could be placed anywhere in the shower (top left corner) was a definite improvement over the existing system. Therefore, I decided to explore this element further. Along with this, the inclusion of an IV infuser that was ergonomic could allow for an overall lower profile system. Part of the focus of these sketches was to explore the shape and size of adhesive patches used with a clip to help manage the IV line.

Focused Improvement

Although my focus was on improving the overall system's usability, I decided to explore the feasibility of this design direction through the design of only the IV infuser. This single focus allowed me to highlight a specific element of the system and explore it in greater detail before taking the findings to the rest of the system.

Exploration of usability focused infuser designs (*Figure 32*). I used these sketches to explore how additions like a suction cup base could make the infuser more stable during infuser changes and which could also be used during showering. Other concepts included more ergonomically shaped infusers which would be more comfortable during use, or collapsible infusers that could be crushed following use to make disposal easier.

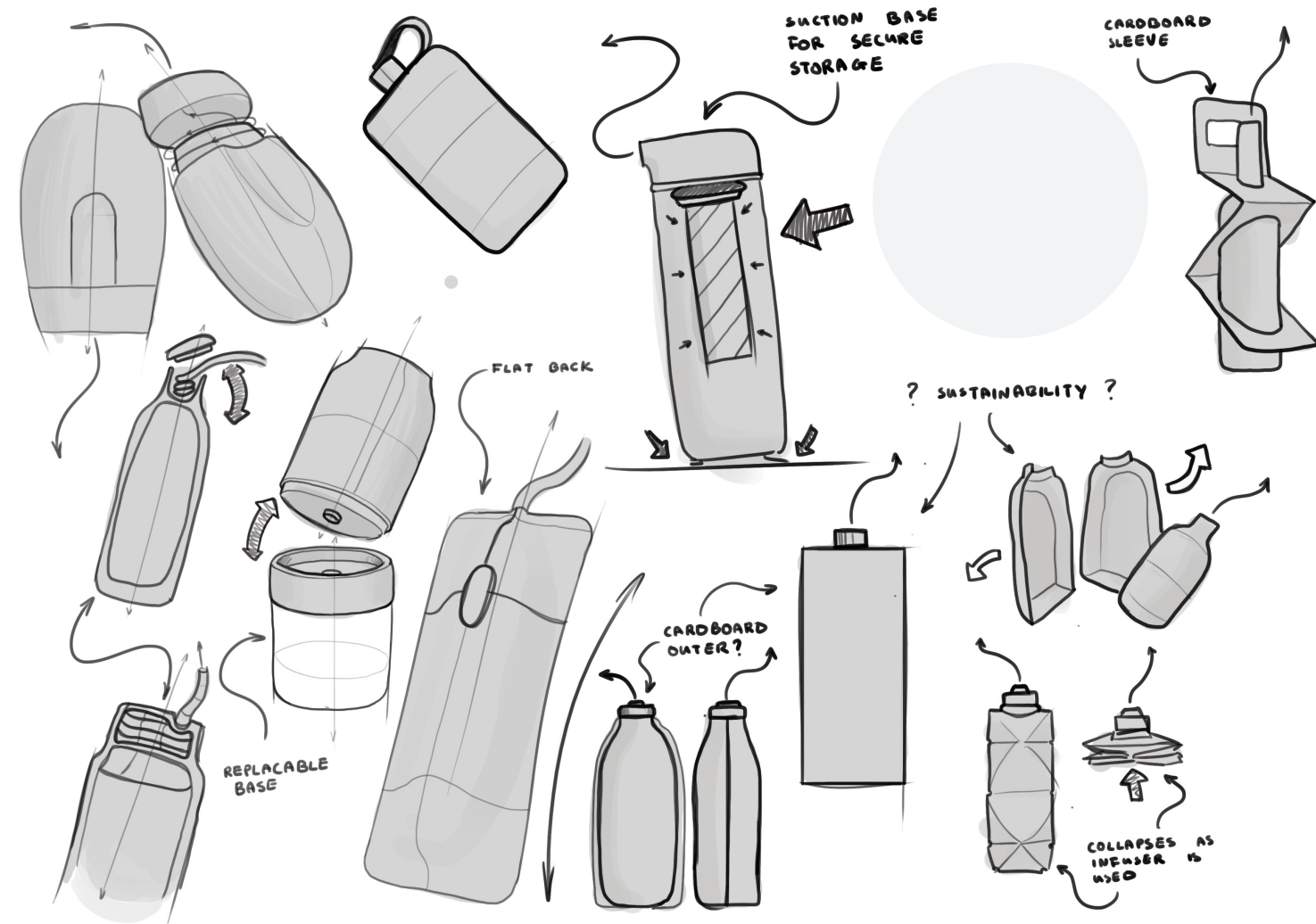


Figure 32. Infuser usability sketches.

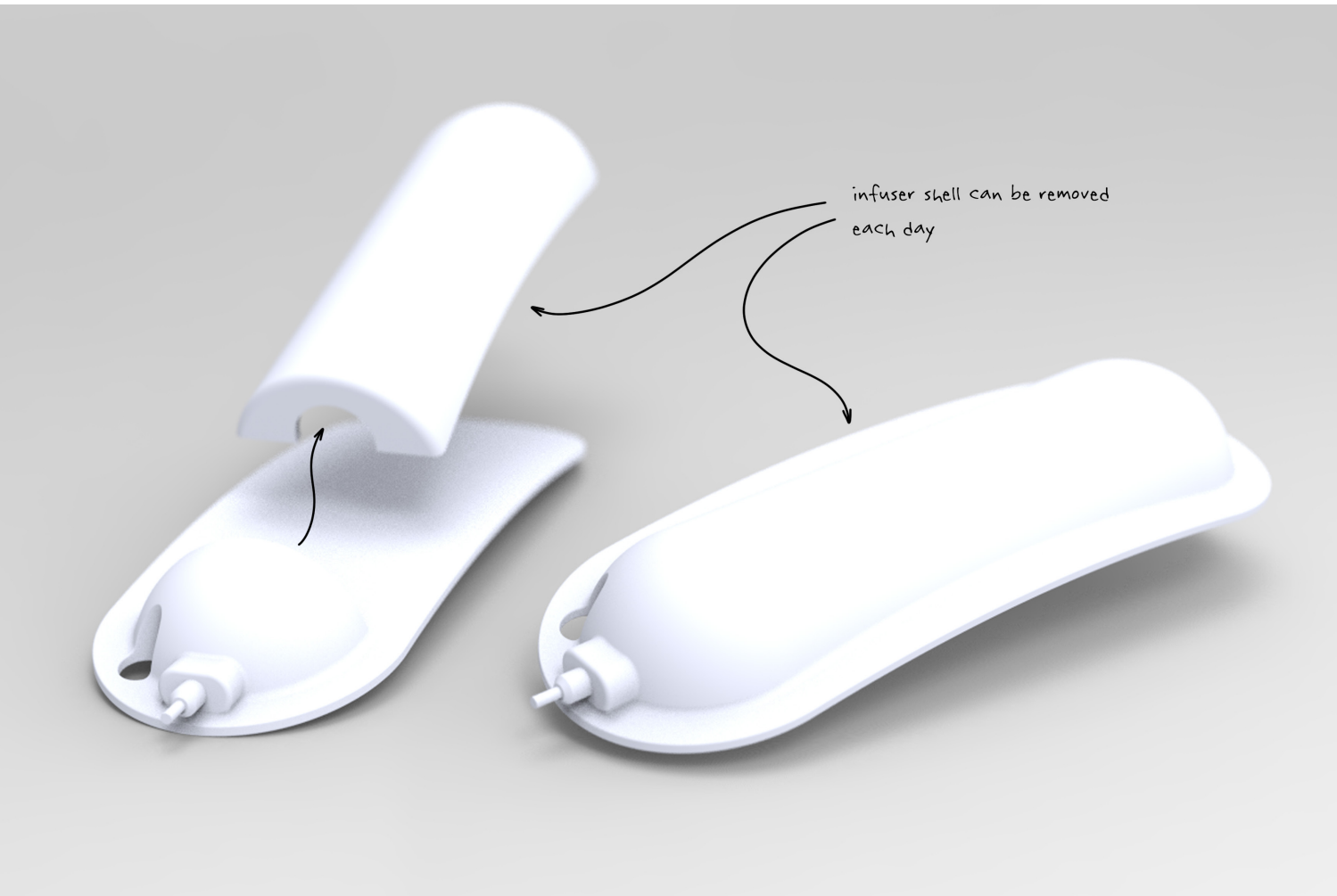


Figure 33. An initial CAD model based on the ideas for a low-profile infuser.

Based on these sketches, I decided to explore a low-profile system (Figure 33.). Taking the existing cylindrical shape of the infuser, I split this in half and curved the flat side; this created a flat edge to be worn against the body. This concept included a built-in hole to use in conjunction with a suction cup in the shower to remove the need for a shower bag.

Although the existing IV infuser system was a one-piece design that was single-use, I wanted to explore if this could be changed to a two-piece system that could reduce the total number of parts discarded daily. Although I explored this, I felt that it added another degree of complexity to the system. As a result, I decided not to take this element further. However, I continued to explore the combination of an asymmetrical infuser shape.

This Section is Continued in the First Expert Critique

Aesthetic Focused

Exploring aesthetics and form language was difficult as, before these sketches, I had not decided on a particular aesthetic. I decided to use minimal contemporary aesthetics as these tended to be more popular among modern design trends (Obendorf, 2009; Syndor & Aileen, 2020). This aesthetic was chosen to be neutral and avoid using colours or form language that may be polarising for different patients and their preferences (Personal Communication OPIVA Nurse Expert Interview, November 30, 2020).

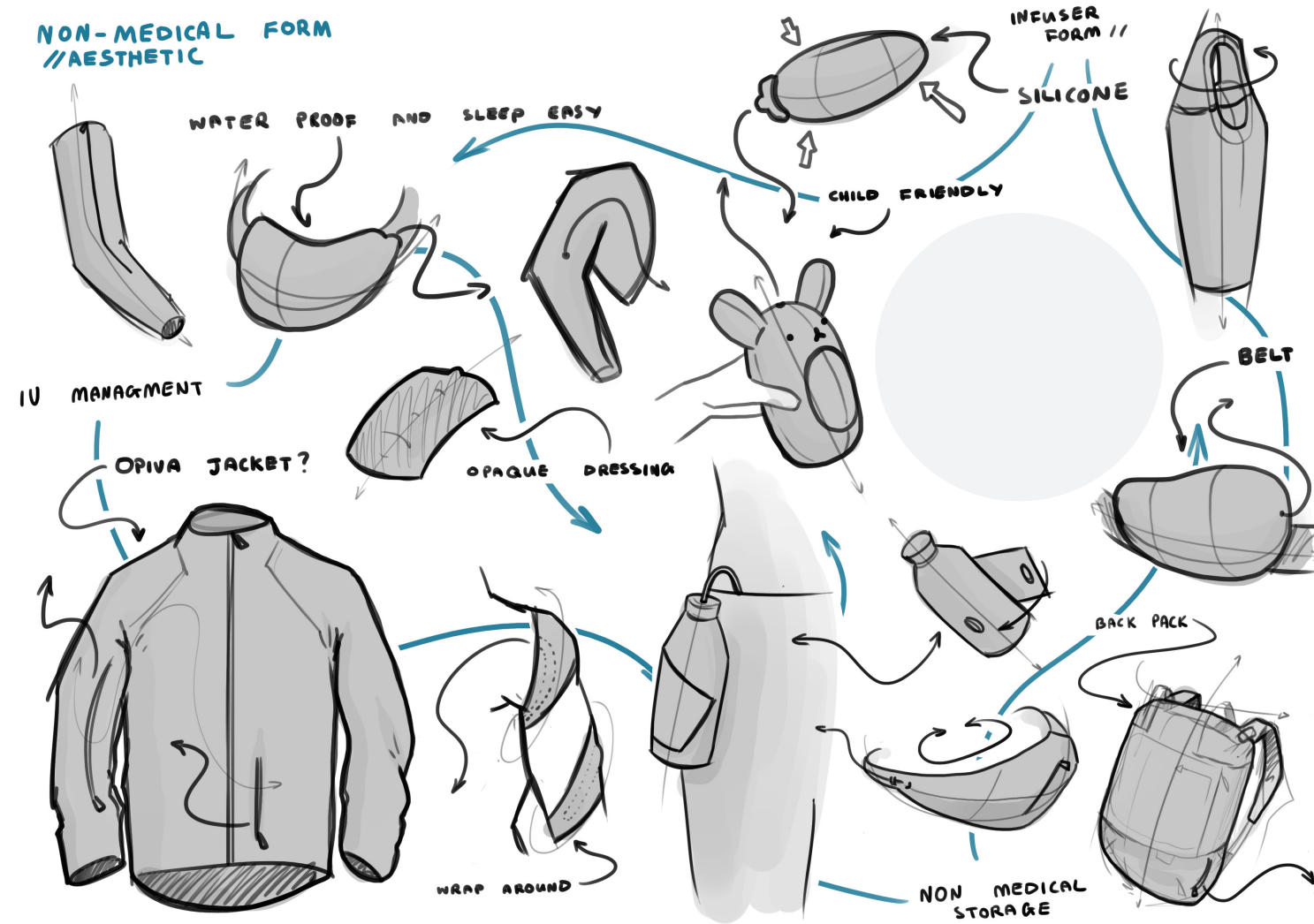


Figure 34. These sketches explored ways the OPIVA system could be radically changed to appear, unlike traditional medical products.

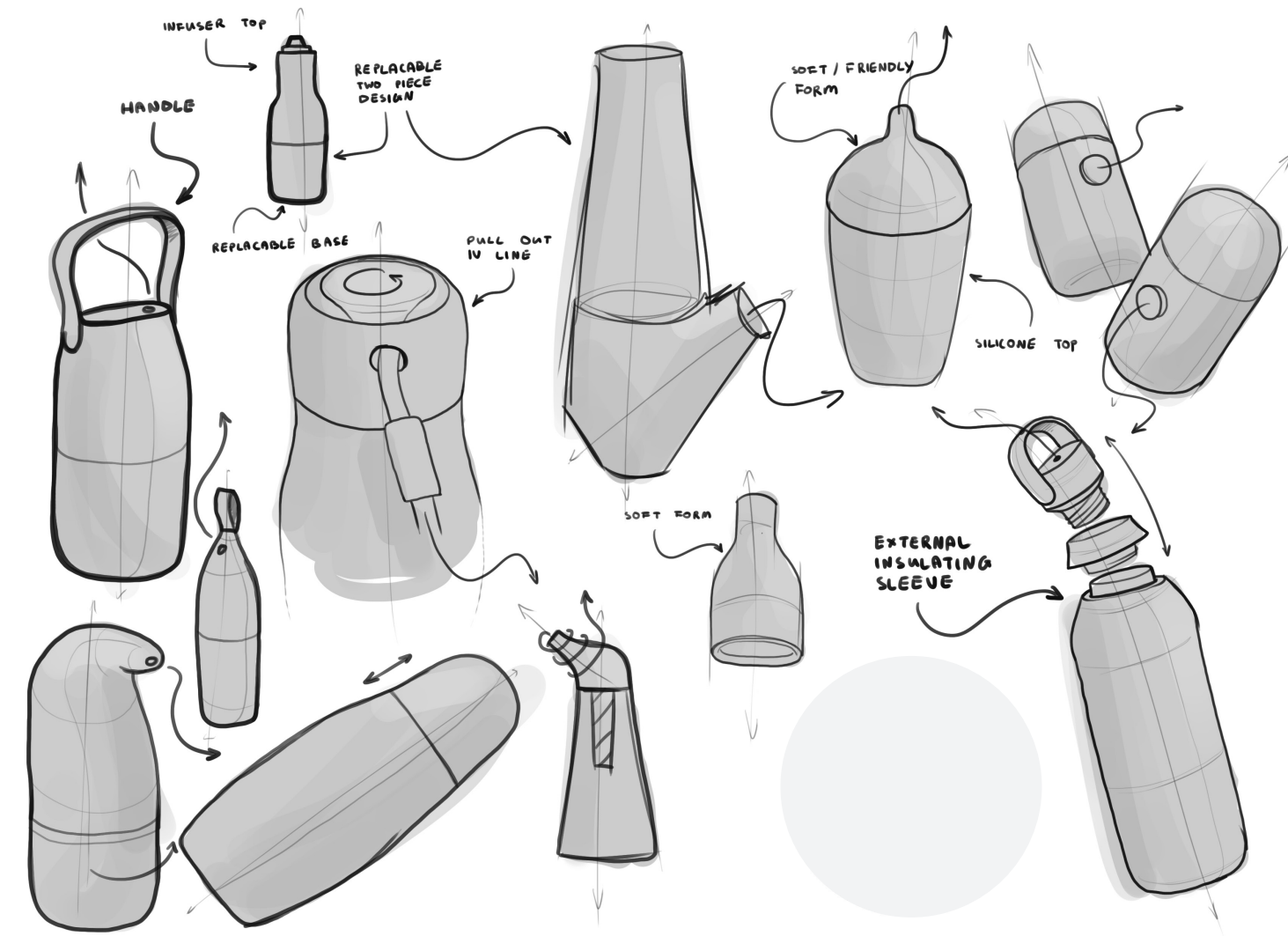


Figure 35. Early sketch exploration of non-medically inspired infuser shapes. These were primarily inspired by water bottles and other fluid holding vessels.

Focused Improvement

As with the usability focused design direction, I explored the feasibility of the aesthetically focused design direction through the design of only the IV infuser.

I decided to explore a function and form language based on water bottles. These were often made with attachments that allowed them to be hung from a user's belt or waistband. Rather than requiring a large bag to insulate the infusers, I explored ways the bottle could have a simple insulating and reusable sleeve instead. I used a form language that many people have prior experience with by taking design cues from existing products. Using prior knowledge and familiarity in design form language can improve intuitive use of the design (Blackler et al., 2003).

The existing Baxter brand infuser featured a simple contour around the top of the infuser, keeping the IV line in place during shipped and during storage (*Figure 36.*). This system was simple and effective; however, the IV line could still be damaged in this design. Therefore, I wanted to explore how the IV line could be stored in a different location.



Figure 36. Image of the existing infuser IV line system with annotations to depict line storage. The IV line was wrapped around the top of the device during storage, and a positive pressure valve was threaded onto the flow restrictor to keep the PICC line sterile.

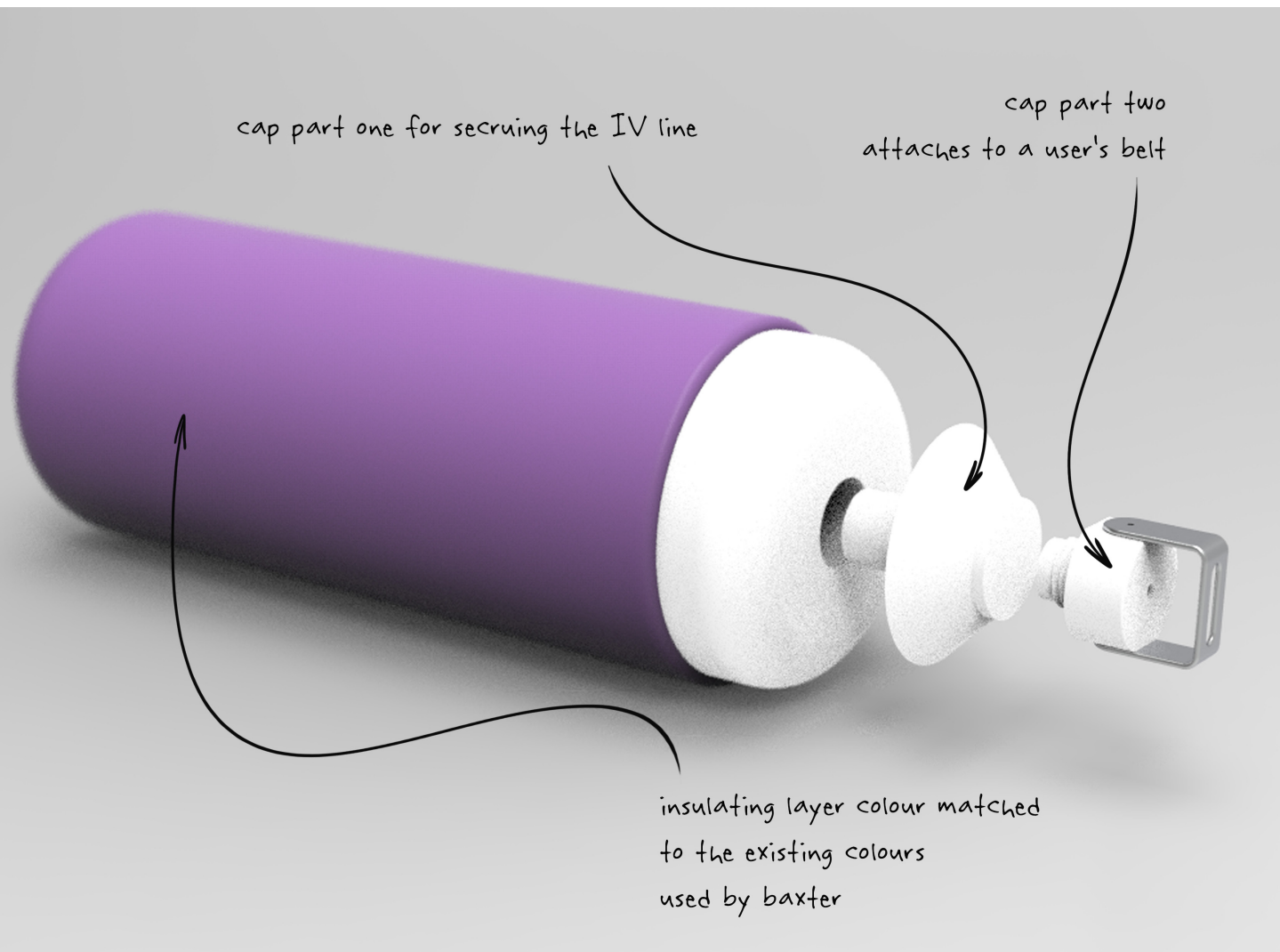


Figure 37. Following the sketches, I constructed some low fidelity prototypes and a CAD model of the bottle style infuser to explore the 2-piece cap design and belt attachment method.

Following my initial sketches, I decided to explore a solution that used a 2-piece lid design. The first part was threaded into the main body of the infuser and kept the wrapped up IV line hidden to avoid it appearing like a medical product. The second lid then helped guide the IV line out of the infuser while having a loop to allow the bottle to be placed on a belt loop for day-to-day activities.

Overall, even though this concept used an aesthetic atypical of a medical product, it did not significantly improve user experience. When this design was tested through a low-fidelity prototype, I found that, although hooking the bottle onto a belt loop could work, the bottle would swing around. This design was uncomfortable and impractical for day-to-day use.

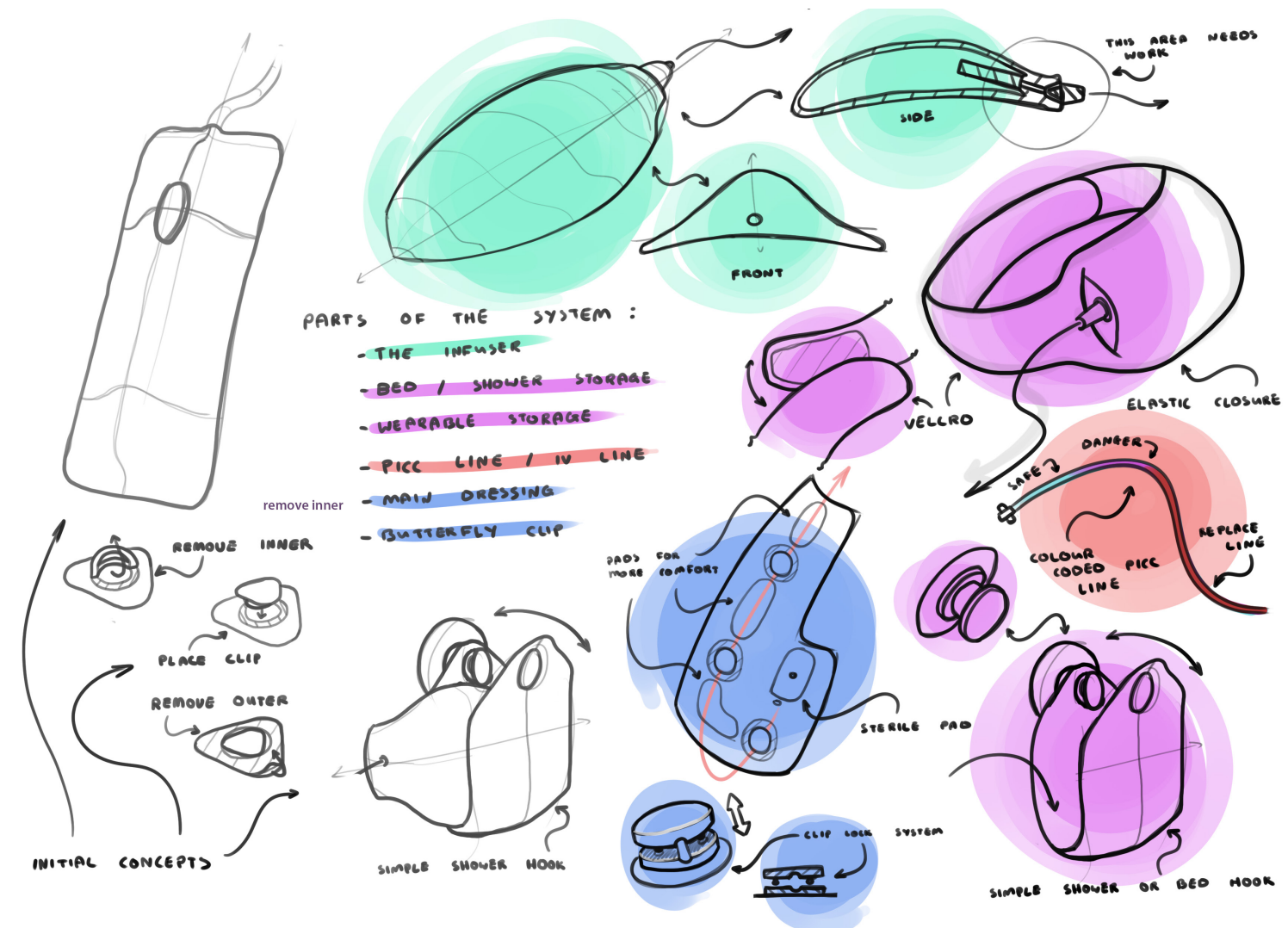


Figure 38. The two versions of the infusers were expanded upon with sketches to explore a redesign of the whole OPIVA system. Ease of use focused sketches are shown above.



Figure 39. These sketches focused on the exploration of an OPIVA treatment system which removed the existing medical aesthetic of the system. Both of these sketches were then used as prompts for the first expert critique.

First Expert Critique

Expert User

The first expert critique session took place with the expert user. The feedback session mainly focused on gathering their opinions on the concepts I developed in this project.

The expert user reacted positively to all the presented concepts. In general, the ease-of-use focused direction seemed to be more favourable for the user generally. The clip-lock IV-line system and the suction cup shower bag were both the most well-received concepts. We also discussed the best positioning for the IV infuser on the body. The waist system was identified as most appropriate because the infuser could be easily rotated to the side and to avoid intruding on day-to-day activities.

The non-medical aesthetic system focused on an infuser that could be worn outside the patient's clothing to provide extra storage. However, the expert participant reported a preference for an infuser worn under clothing. They preferred a hidden infuser, even if this meant retaining the medical aesthetic of the existing system. Although some of the patient participants I spoke to said that they enjoyed the extra storage the waist bag provided, younger patients might prefer an under-clothing IV system (Ackermann et al., 2007; Dodd, 2007).

Based on this interview, the clip lock IV line system, under clothing infuser and a shower storage system was carried on into the later stages of the research. For the infuser to be worn comfortably under clothing, it needed to be ergonomically contoured to fit the body. In addition, the bag needed to be low profile while still providing insulation for the infuser.

“That looks a lot more user friendly than a bottle with six sides.” Expert User Participant

05.6. Stepping Back - Refining the Design Brief

Refining the Design Brief Based on Initial Ideation

Through my initial sketches and prototyping, I started to feel like there was space for a radical change to the existing OPIVA service. The OPIVA service can effectively be reduced to one key concept: to provide patients with a steady flow of antibiotics through a central line over a six to eight week period. Although this seems simple, it leaves room for possible design developments. For example, I could create a system that allowed for regular self-infusion more efficiently than using an automatic infusion device. However, I decided that for the research to be successful, a more direct approach would be needed. Although a more radical improvement to the OPIVA service could be viable, hospital management's adoption of product changes can be slow, with many barriers to implementation (for more information, see "Barriers to Product Implementation" in chapter 06.2) (West, 2020). This decision, and insights from the first expert critique session, led me to change my focus from separated non-medical aesthetic and ease of use focuses and to combine these to create one product outcome.

Based on my findings at this point in the research, I decided to refine my direction and focus further. A limitation of my research was the low number of participants (N=8) (for more information, see "Participation and Recruitment" in chapter 06.2). As a result, some assumptions around aesthetics and form language were made. A range of prior literature has shown that a product's aesthetic can play a role in a user's sense of self, with products perceived to be more aesthetically pleasing increasing self-affirmation (Townsend & Sood,

2012; Boradkar, 2010). Patients also tended to prefer products designed around a 'modern' aesthetic (Syndor & Aileen, 2020). Therefore, creating a product that valued aesthetics and was perceived by users to be aesthetically attractive was necessary. Based on existing product design in healthcare research examples and existing medical products designed with a human-centred approach, a focus on minimalism and calming colours were chosen as an appropriate aesthetic direction and colour palette choices for the focused design process (Caspari et al., 2007; Greenhalgh & Balloffet, 2021; Syndor & Aileen, 2020).

The IV Clips and Dressings - Requirements for Design

The IV clips were a solution to remove the need for tape to hold the IV line in place. These clips were used to avoid any kinks or hindrance in the flow of the IV line. The clips needed to function in conjunction with the sterile dressing, which protects the PICC line insertion site and the PICC line stabilizer.

Intuitive function – The clips should have been easy to use, with little instruction needed to understand how they should be used.

Secure fit – The IV clips should hold the IV line in place securely without hindering the flow of the antibiotics or damaging the IV line.

Ease of use (including use with one hand) – OPIVA patients had the PICC line inserted in one of their arms which meant the IV line needed to be managed using only one hand. In some patients, this may be their non-dominant hand.

IV-line flexibility – To avoid any flow restriction while keeping the line securely in place, the IV clips needed to prevent pinching or compressing the IV line in any way. In addition, the IV clips should allow the IV line to move and remain flexible.

Comfort on the user's skin – Many OPIVA patients were elderly, and skin damage was common from dressings and medical devices when worn on the user's skin for extended periods (Todd, 2018). The IV clips should be shaped and mounted in a way that allows for regular repositioning to avoid skin lesions.

The IV Infuser - Requirements for Design

Fit against the body – The infuser should fit comfortably against the user's body, specifically around the user's waist. The infuser should fit well when inside the bag without any pressure spots or hard edges.

Easy infuser changes – During infuser changes, the infuser should not move or roll around when resting on a flat surface. In this position, the IV connector should not contact any surfaces to avoid infection risk.

Low profile fit under clothing – The infuser must remain comfortable under the patients' clothing when inside a storage bag.

Fit on different bodies – Different users would have differently shaped and sized bodies. One limitation with the current infuser waist bags was the lack of size variations for patients. Therefore, the infuser bag needed to be producible in different size options to fit various body types (e.g., small, medium, and large). The curvature of the infuser should also allow for comfort on a range of body types.

Infuser line position – For the infuser line to function similarly to the existing system, the infuser IV line needed to be run under the patient's clothing to their arm. The infuser, therefore, needed to have the IV line positioned in such a way as to allow an unobstructed flow of antibiotics while avoiding placing pressure on the patient while wearing the bag.

Additional design criteria were considered and were presented in Appendix E.

05.7. Refined Ideation

Ideation Based on the Refined Design Brief

Although the following stages of the research were done simultaneously, each area of the system (the infuser, IV-line management, infuser storage and system extras) were grouped in this document individually. I have arranged the creative process in this way to highlight each element more succinctly.



Mood board images removed for copyright reasons.

Figure 40. This mood board was used to explore aesthetics, focusing on form language, material choice and colour palette. I decided to use soft pastel (calming) colours and colours currently used by Baxter (Baxter, 2021; Greenhalgh & Balloffet, 2021).

The Infuser - Further Refinement

Refined Ideation Sketching and CAD Modelling

Initially, I wanted to explore the form of the infuser without directly addressing its functional elements. The most successful designs were the curved square form (highlighted top right), a tapered curved style form (highlighted top left), the bean-shaped form (highlighted bottom left) and then the longer soft form (highlighted second from the right) (**Figure 41.**). Each used a slightly different shape while remaining low profile and ergonomic when worn against the body (based on my assumptions and previous testing). Based on these sketches, I produced CAD models to explore each concept using a more refined ideation method.

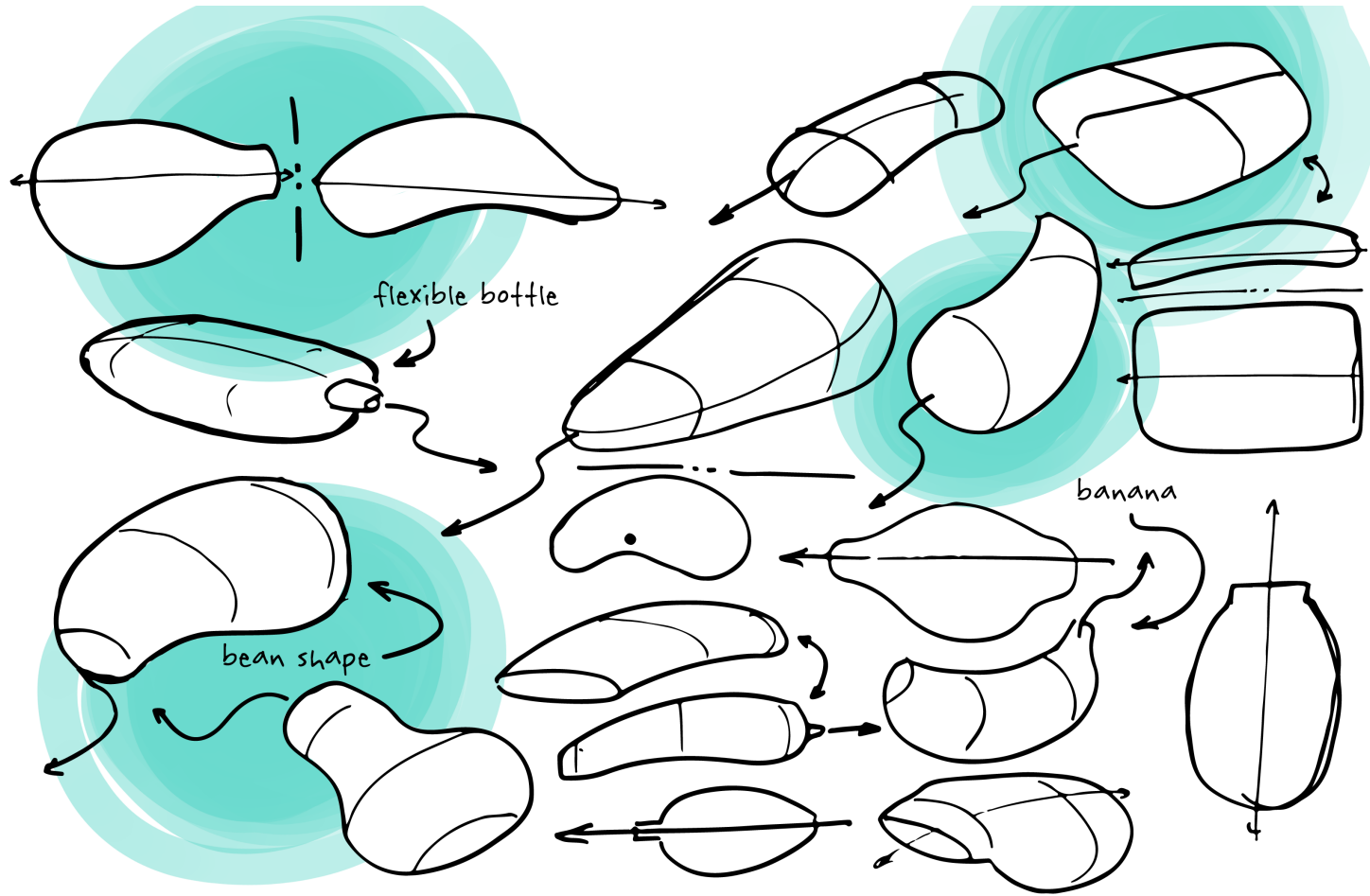


Figure 41. Infuser form refinement sketches.

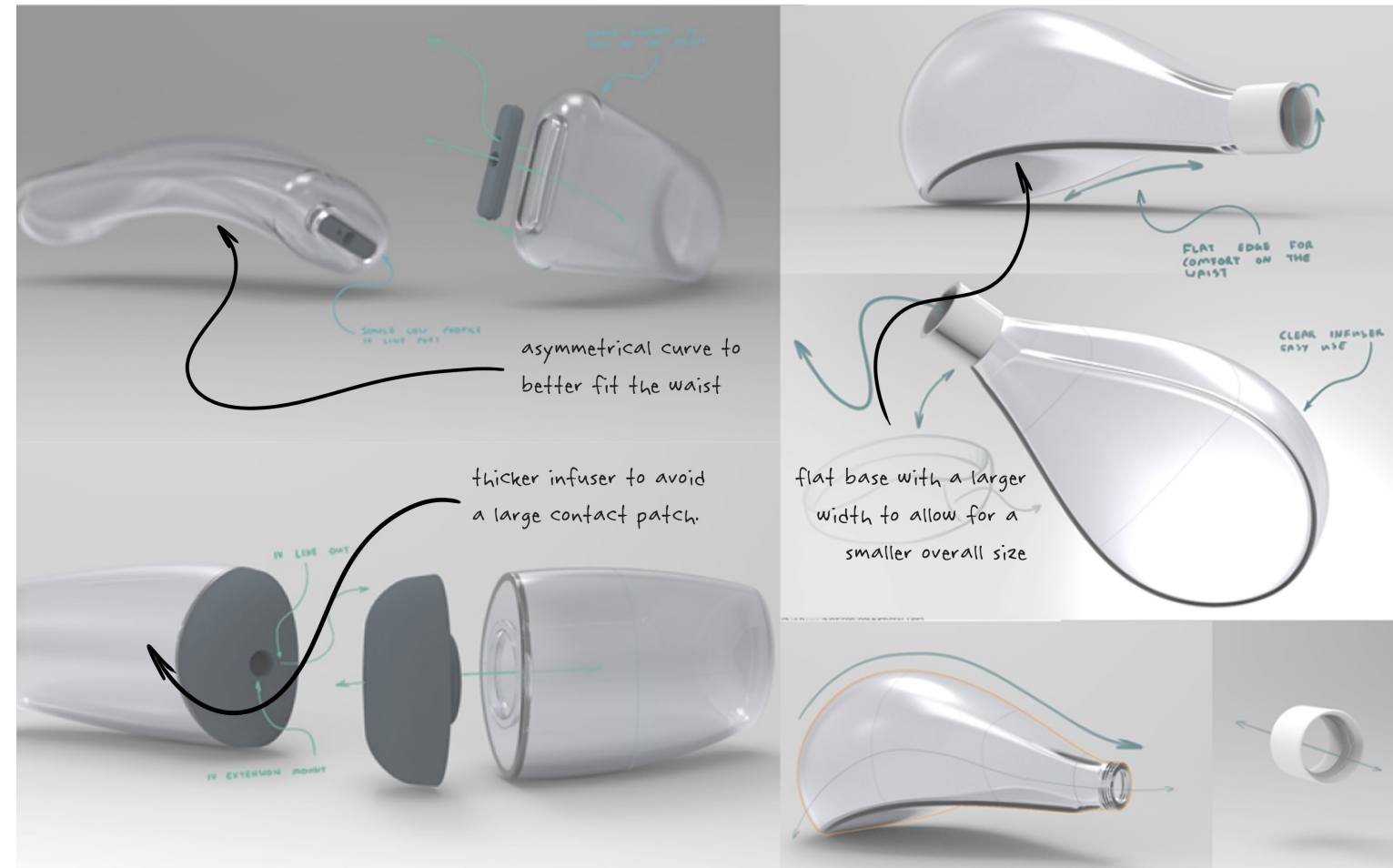


Figure 42. Based on the initial refocused infuser sketches, I constructed several different CAD models. These models refined the sketches in 3D to explore the function and form of the infusers more accurately. These were then used to produce foam models.

Form Exploration with Foam

Following the initial CAD models, I explored these concepts further by developing them into a series of foam models. These models were used to test scale and fit against the body. Each design was then rated and evaluated using an evaluation matrix based on the infuser requirements defined in the design brief. Unlike the CAD models, these foam models did not directly explore IV outlet or cap designs and instead focused more on the shape and form through a rapid prototyping method.

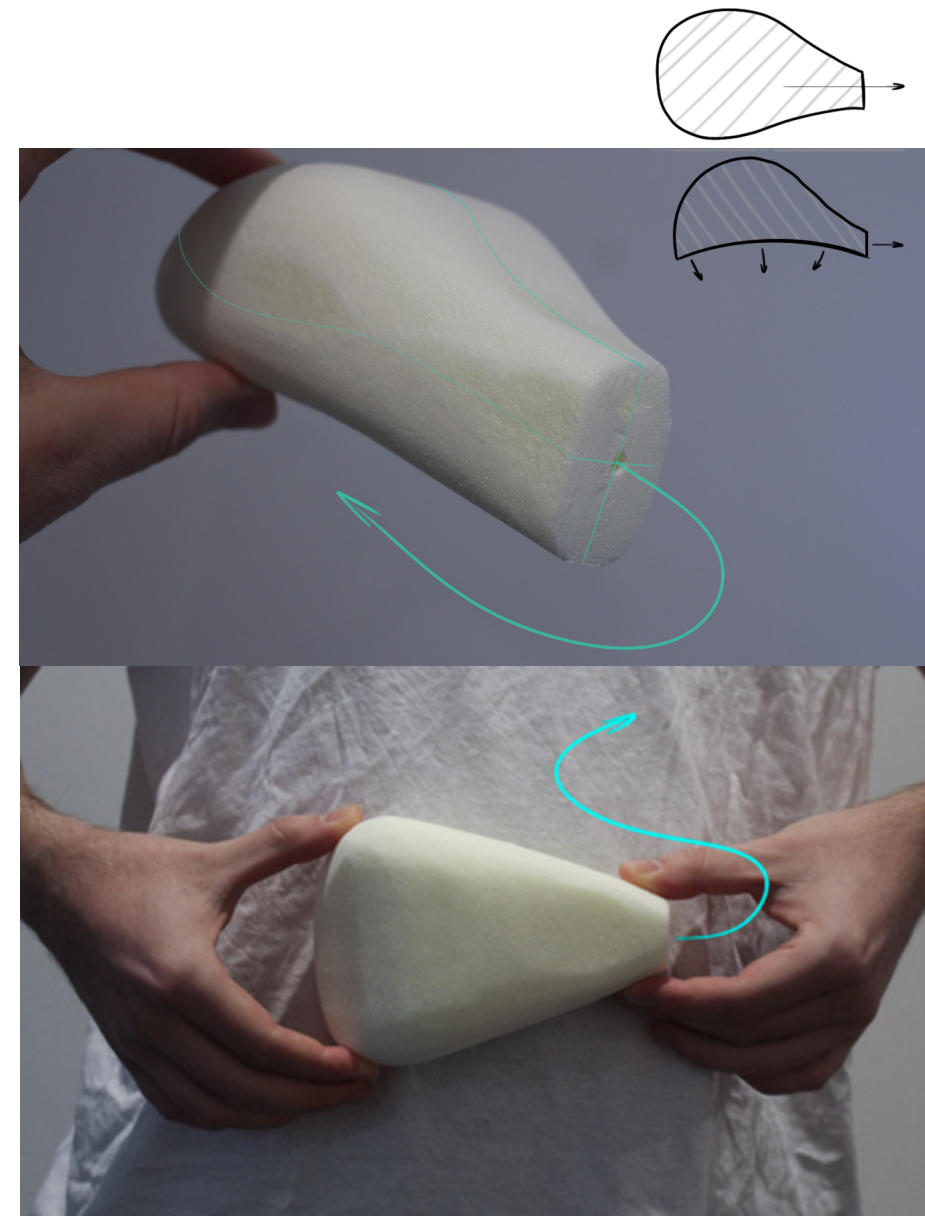


Figure 43. This design featured a slightly curved base with a larger reservoir; along with this overall form, I wanted to explore how the IV outlet could be a 'slot' shape rather than a cylinder.

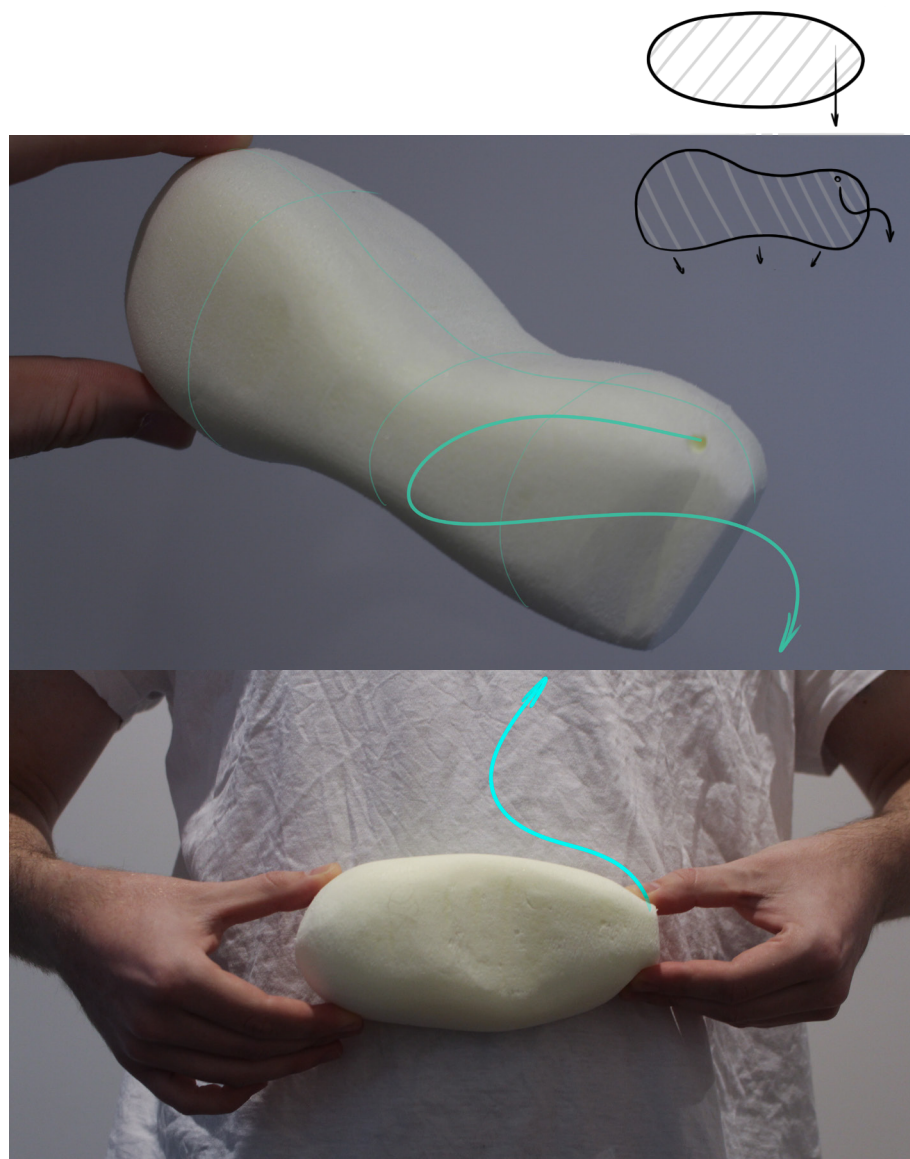


Figure 44. I used this concept to explore a different IV-line placement along with a pear-shaped shell. This pear-shaped form could allow for IV line wrapping during storage. The IV line was positioned so that it would exit the top of the infuser rather than the end.

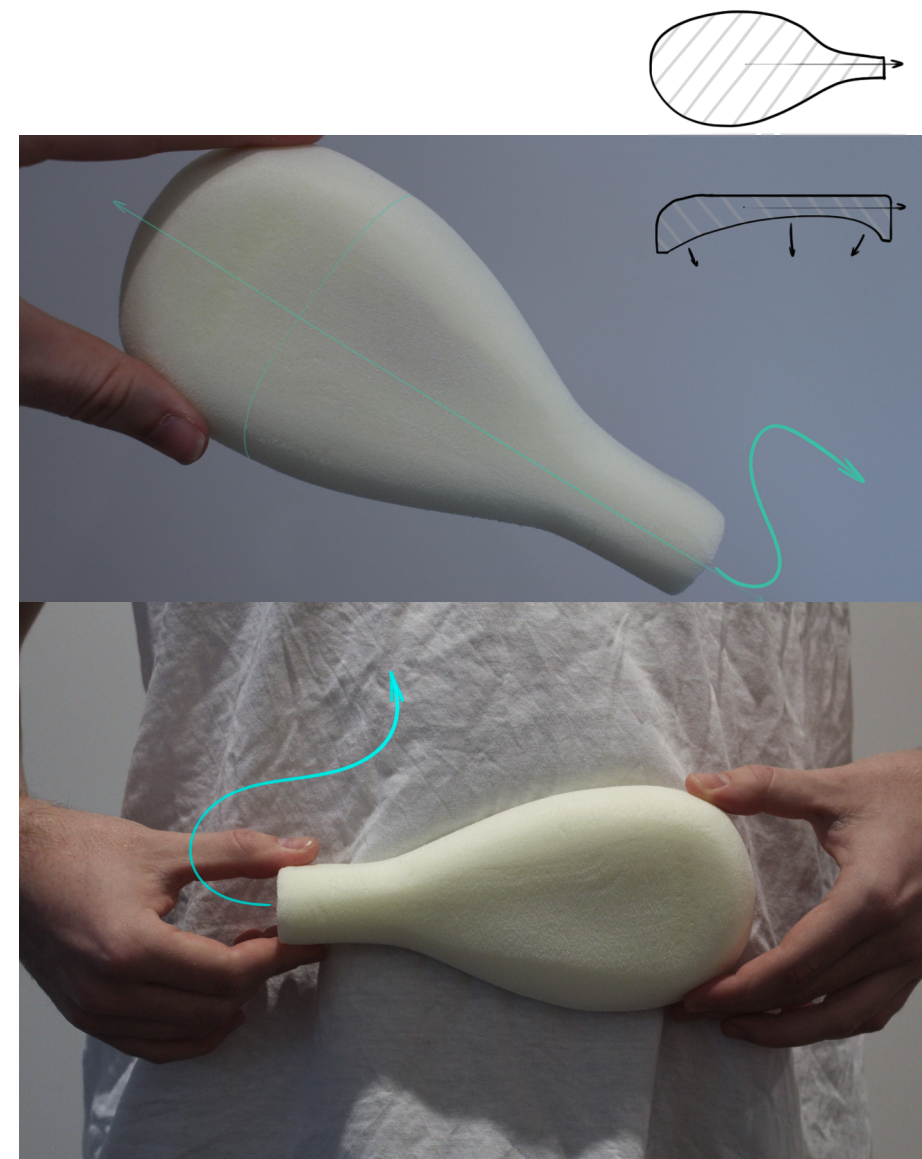


Figure 45. A wide base and narrow neck form. This form was given a lower thickness to closely fit the body and a flat base for resting on surfaces during infuser changes. The lower overall thickness was at the expense of a larger contact patch with the user.

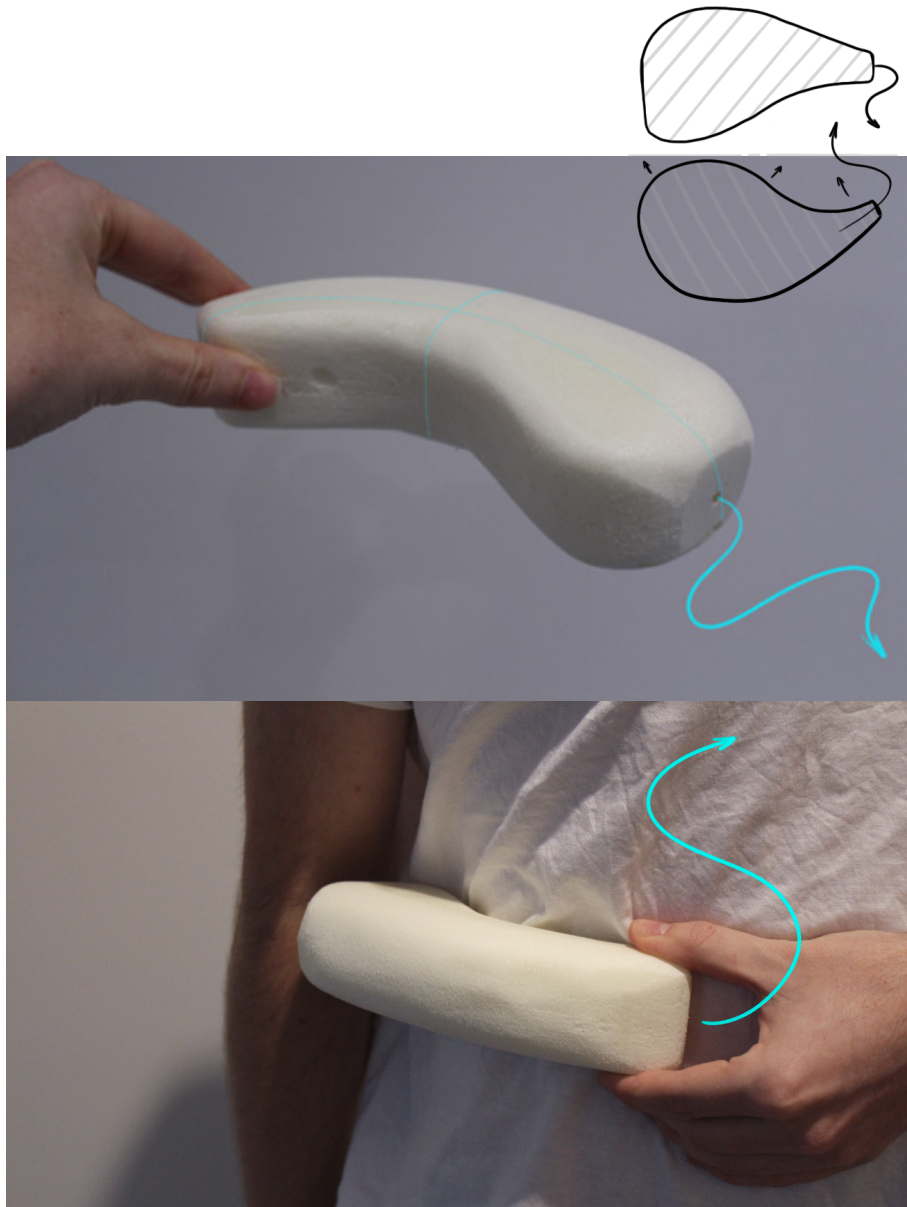


Figure 46. I used this concept to explore how the infuser could fit on the side of the hip (like the previous concept). This concept featured a consistent thickness throughout to avoid catching on clothing.

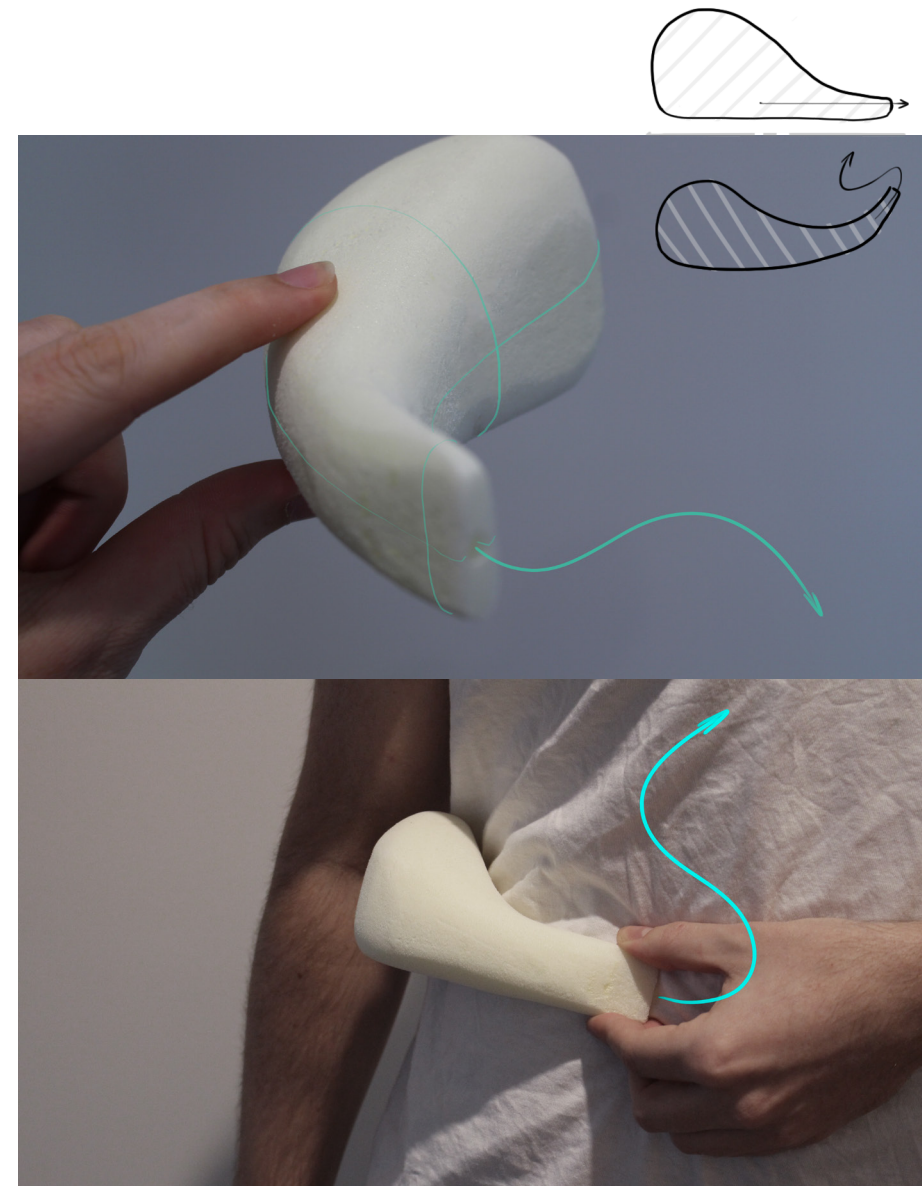


Figure 47. This infuser used a broader base, curved to a narrow neck with a softer overall form. I wanted to explore how a more aggressive curve could be used in the infuser to fit in the waist curve rather than lower on the hips.

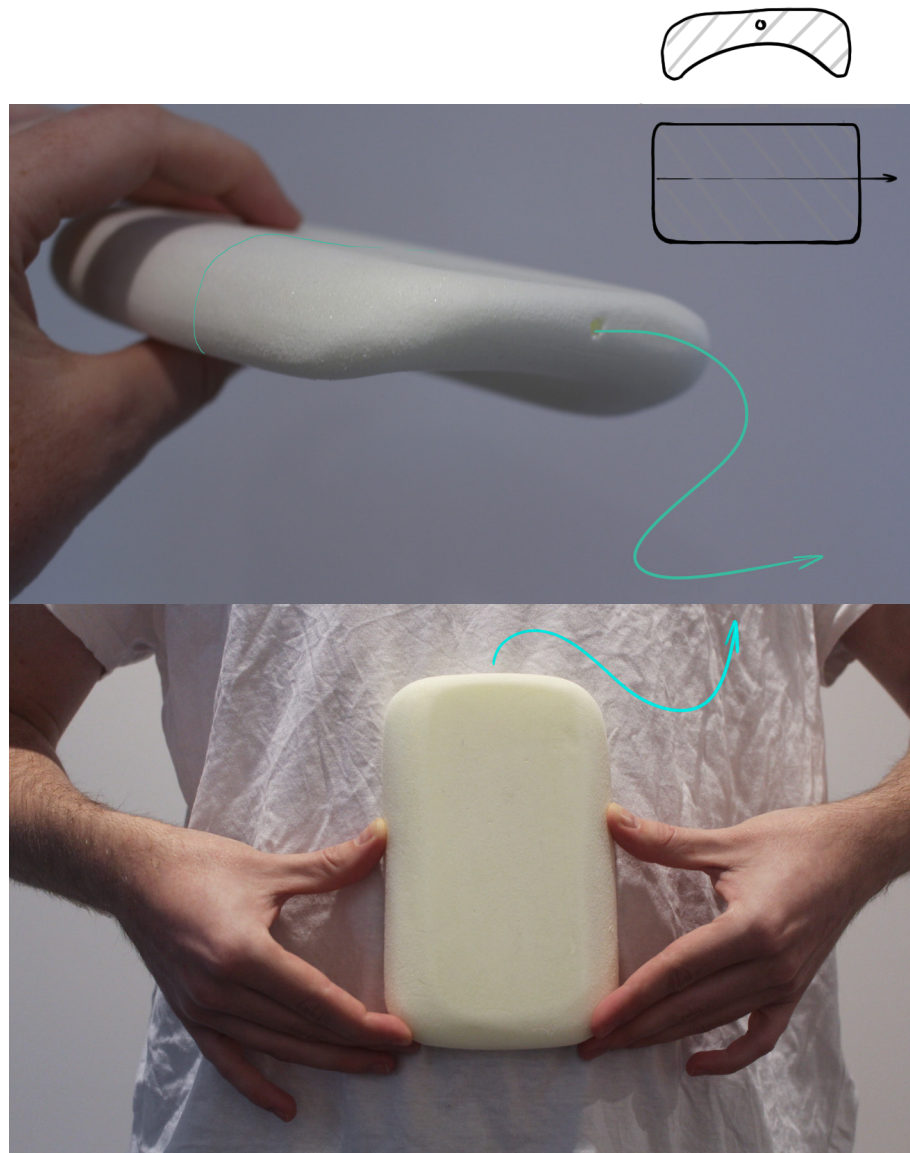


Figure 48. A flatter infuser with a concave base. This infuser shape would be placed on the front of the abdomen rather than the side.

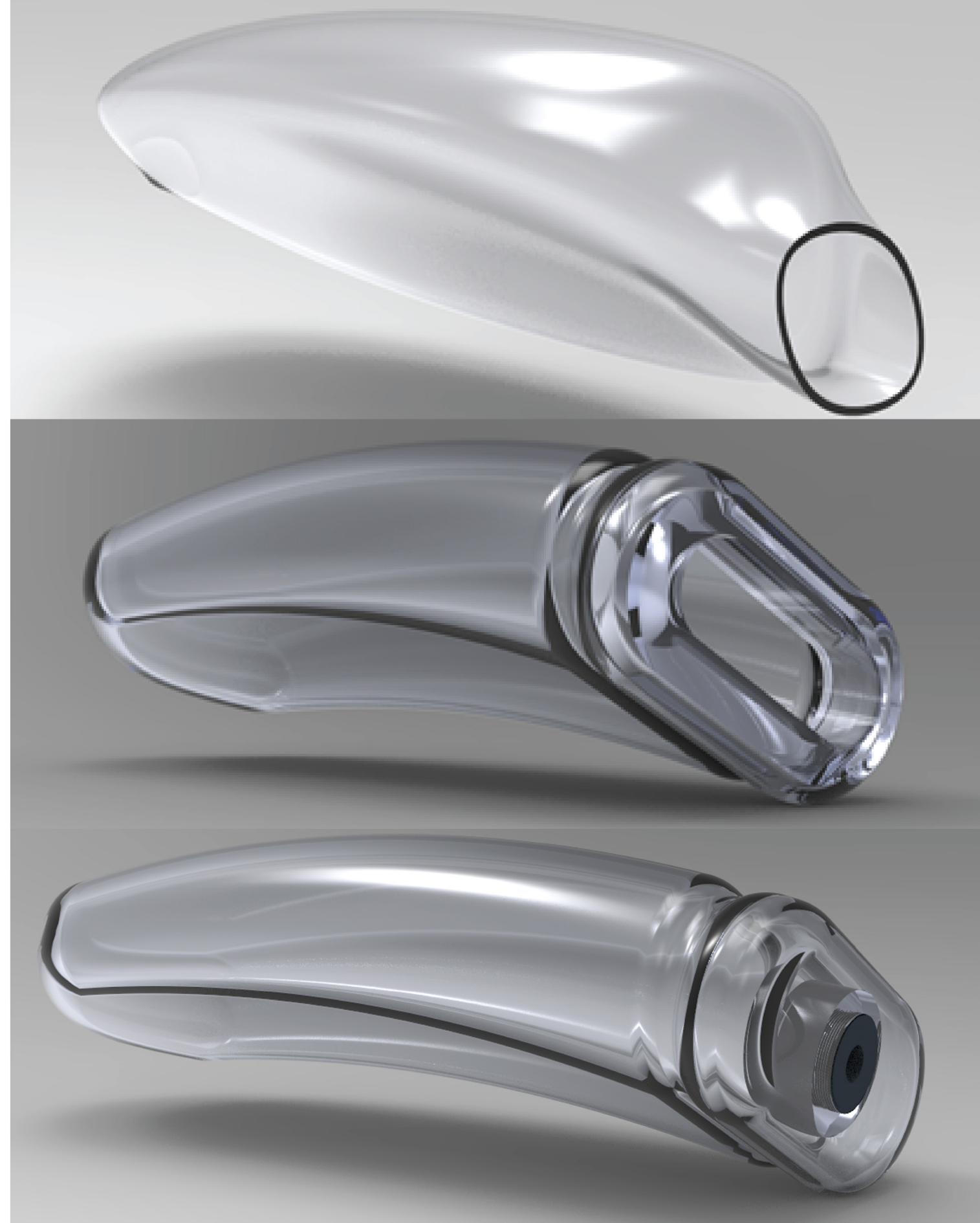
fit against body	9	6	4	3	3	6
easy infuser changes	6	4	8	6	9	8
low profile	3	2	9	4	4	9
fit on different bodies	7	6	1	5	4	3
infuser line position	5	7	5	6	6	5
Production cost	6	5	6	4	4	6
	36	30	33	28	30	37

Figure 49. Infuser concepts evaluation matrix. Each model was analyzed based on the features for the infuser set out in the design brief. The foam models were tested on the researcher's own body to explore how they would fit, both over and under clothing. These tests highlighted some concerns with several forms as hard edges would create pressure points if not correctly placed. Designs that balanced soft curves and avoided hard edges which might contact the user's body were most successful.

Infuser Ergonomics

For the infuser to be worn under clothing, it needed to have a low profile form while remaining curved to fit the body comfortably. Although the patient participants of this research were all over 40 years of age, the OPIVA service had patients of many age groups, ethnicities and genders (Personal Communication OPIVA Nurse Expert Interview, November 30, 2020). I wanted to ensure my products would fit the widest range of users possible. To do this, I considered the average waist circumference for New Zealanders aged over 15 (930 mm) and used this as the basis for the infuser shape in the later stages of the research (Understanding Excess Body Weight: New Zealand Health Survey, 2015). I ensured the infuser could fit users outside this range by avoiding hard edges and allowing for a range of users, both bigger and smaller.

Figure 50. Following the foam models and infuser evaluation matrix, I went back to CAD modelling to explore more refined concepts. These considered both the shape of the shell and the IV outlet function. Each design was based around a 296mm radius (930/3.14) to contact the user's waist. The first concept used a rough ergonomic form, which I then developed into a subsequent model focused on using regular forms (which would be easier to blow mould). The final CAD model developed here used a threaded IV control point. These concepts were used as the starting point for developing two infuser concepts leading into the second expert critique.



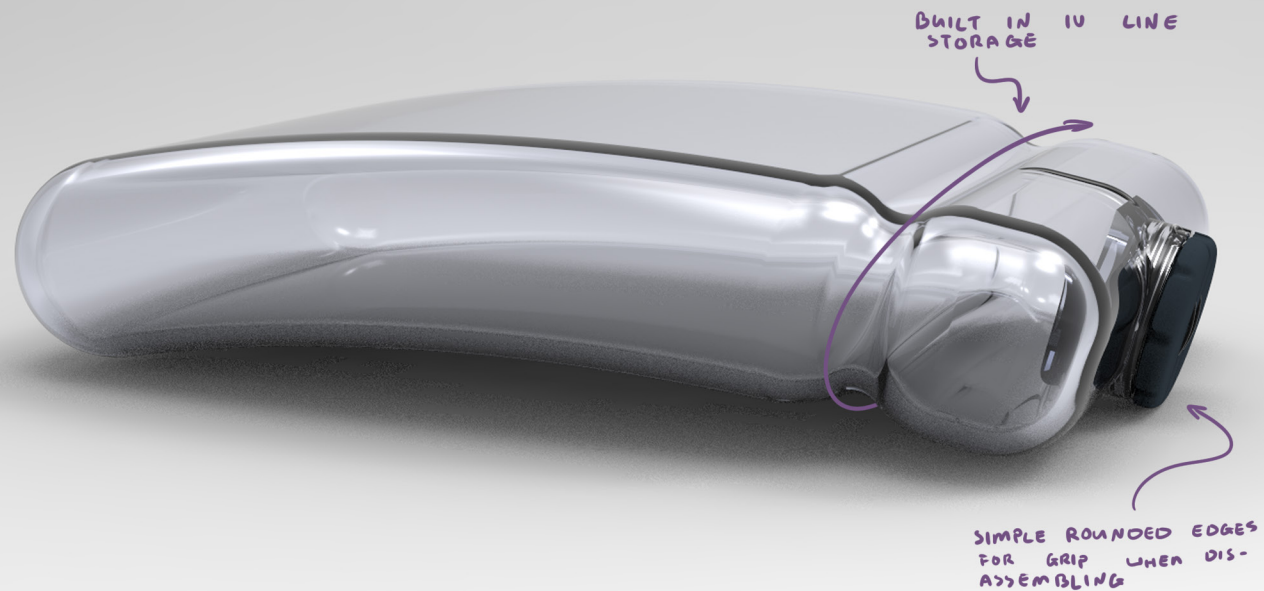
Infuser Ideation Refining

Moving from the initial refinement stage of the infuser design process, I did a second refinement cycle of the infuser design. These aimed to explore two different versions of the infuser. Each highlighted a key area that was the focus of their respective designs. These designs were subsequently used as research probes and concepts presented in the second phase of expert critiques.

Rounded Shell Infuser

This infuser aimed to avoid any sharp edges and fit a broad range of users by having a larger edge radius. The first iterations of the rounded shell IV infuser (*Figure 51.*). I took the blow moulded form I had explored earlier in the design process and explored alternative cap designs. I wanted to balance a system that would be easy to dismantle, yet a patient would not be able to break or remove parts before the infuser was emptied. The first concept was overly complex as it used three parts (a slide fit cap and a threaded IV outlet). The second concept was simpler, as it used only two pieces for the infuser shell and infuser outlet. However, I still felt this design could be made tamperproof and aesthetically pleasing more simply. As a result, I decided the clasp used in this design was unnecessary.





Medical device misuse by patients is a significant issue for medical devices that my designs aimed to avoid (Wiklund, 2005; Lin et al., 2001; Almakky, 2017). Based on my testing, a threaded IV outlet was the easiest and least complex way to remove the IV outlet and elastomeric reservoir (the non-recyclable parts of the infuser) after the device was used. However, a threaded part could be accidentally removed. Therefore, the final rounded shell infuser concept focused on using an anti-misuse measure. This design used a rubber ring to ensure the system was tamper-proof and to communicate to patients that the cap (IV outlet) should not be removed during use.

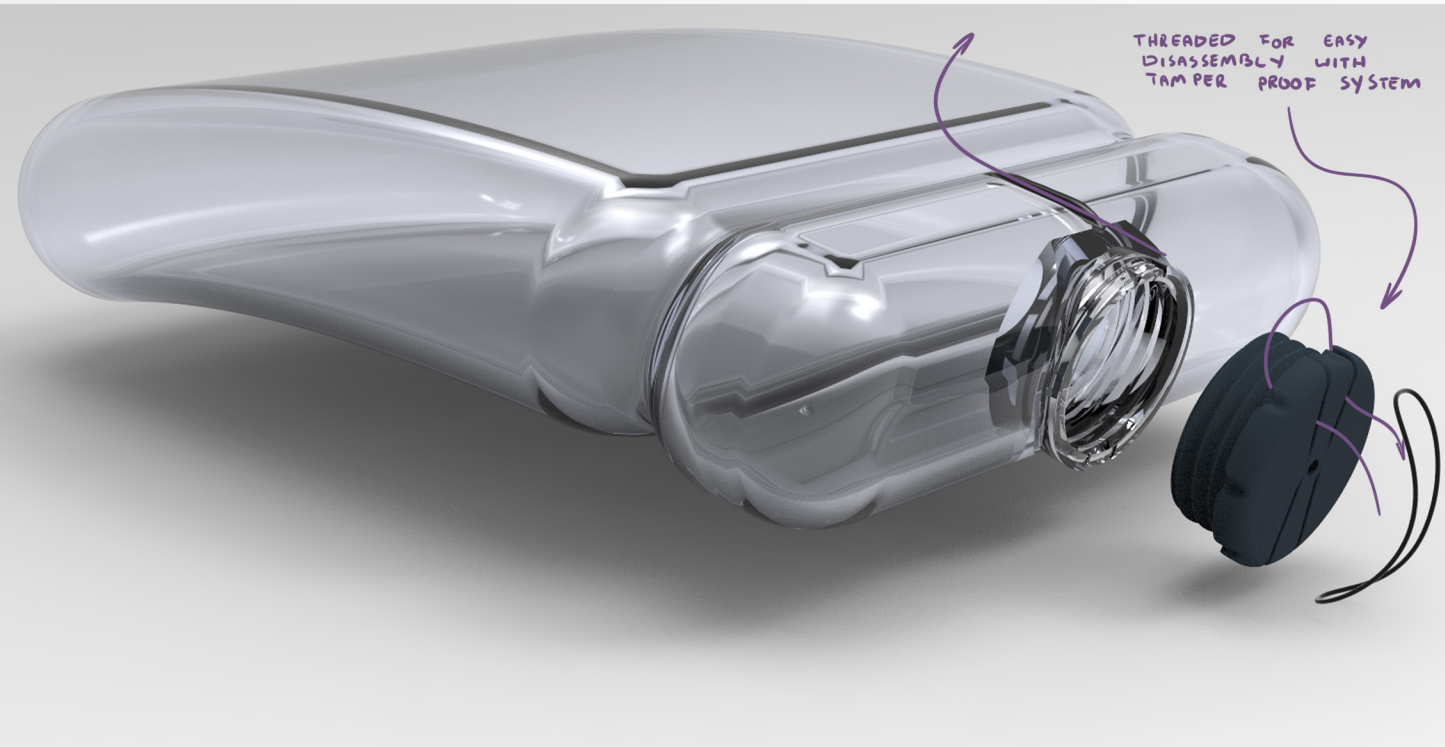


Figure 52. Based on the clasp style infuser, I developed a final concept to be used in the second expert critique.

The flat back of this infuser was formed to fit as comfortably and closely against the body as possible. Many of the designs I had explored used a reservoir control point inserted into the main body of the infuser in the same orientation as the standard Baxter infuser. This slim fit system also explored how different orientations of this reservoir could be used. The main limitation of this design approach was that it would result in extra thickness in the centre of the infuser in the centre it would create. As I explored, I found that the larger the contact patch with the user, the more critical ergonomics were. Specifically, a larger contact patch meant the infuser fit a smaller range of participants.

Some participants described changing the infusers on their laps in the car or on other unstable surfaces (OPIVA staff do not advise this). As a result, this design also created a larger stable platform for infuser changes.



Figure 53. The low profile infuser concept.

Reflection

There was well document research around patient preference of elastomeric infusion devices, although these tended to focus on patient health outcomes rather than day to day activities. Most of the literature concluded that size and weight were leading factors in patient preference, with lighter and smaller infusers being preferred (Dodd, 2007; Ackermann et al., 2007; Zahnd et al., 1999). Based on this data and patient insights from my research, I decided the infuser needed to feature a simple tamper-proof system while being easy to disassemble and recycled after use. and respond to the issues discussed by the participants; hard to wear under clothing, non-sustainable, and uncomfortable to wear.

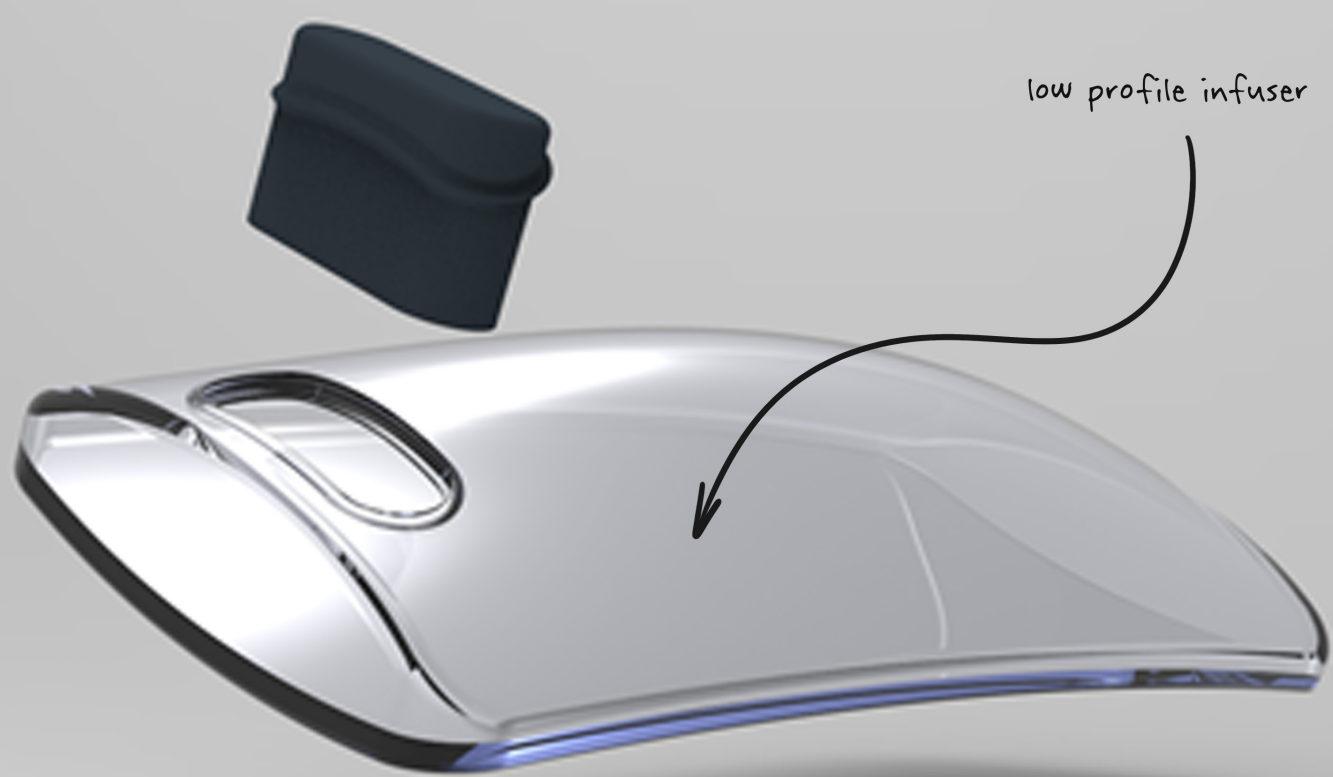
Although through the exploration, I intended to present two hard shell infusers and a soft-shell infuser for the expert critique, during my reflection following this stage of the creative process, I decided that the soft-shell infuser was not a viable option (see Appendix G). Baxter brand elastomeric infusion devices featured a hard shell, and currently, the Waitematā DHB only used hard shell infusers. This research aimed to explore and highlight patient difficulties with the existing system and improve these within the existing system's limitations. The soft-shell infuser sat outside these limitations.

Second Expert Critique

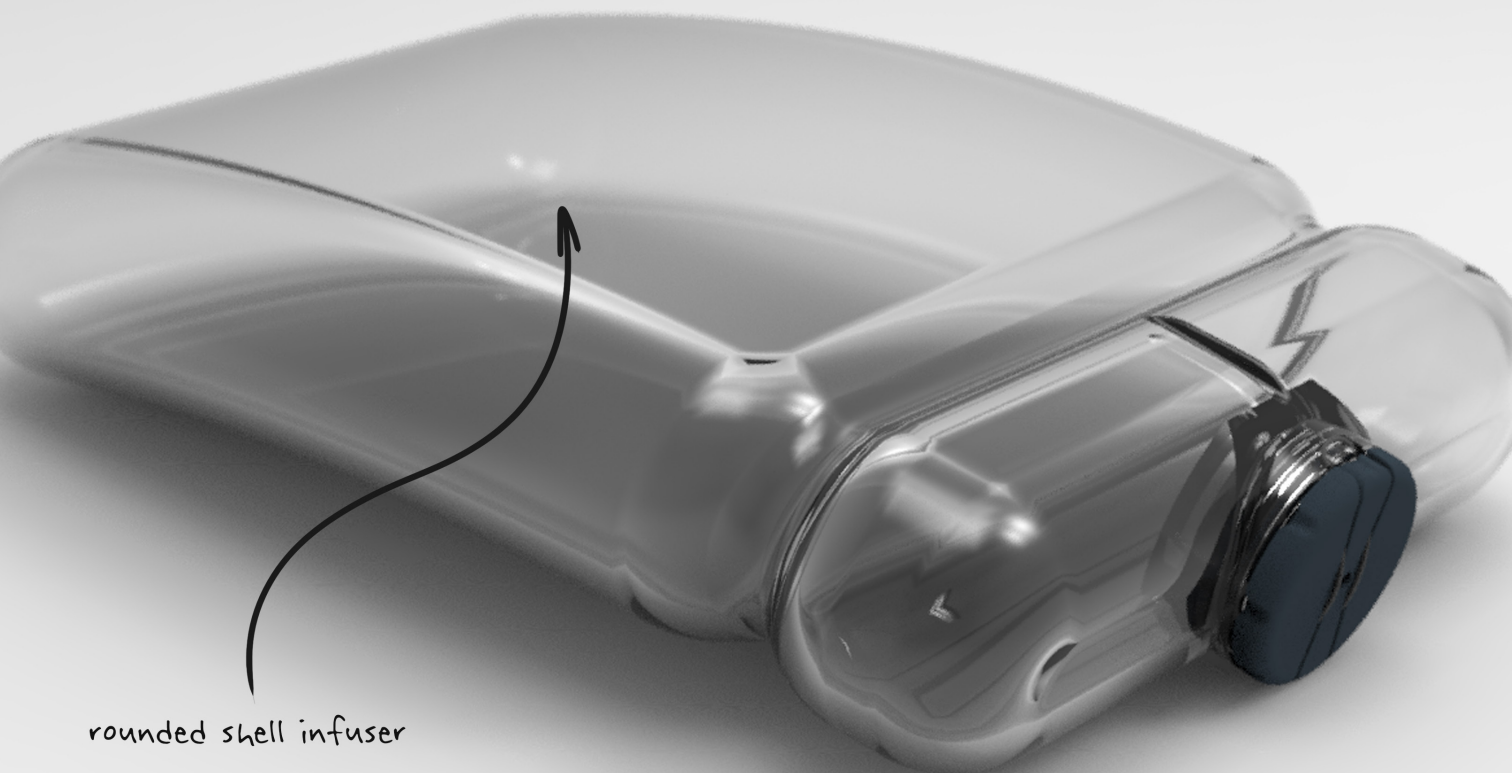
Expert User, Previous OPIVA Patient and OPIVA Nurse

The most successful concepts from each part of the system were presented to the expert user, one previous patient and one of the Waitematā DHB's OPIVA nurses. More participants would have been included, but few patients expressed an interest in participating in this stage of the research. Questions were focused on aesthetics, function, and user assumptions of use. Each design was explained to help provide participants context.

(The second expert critique sessions were broken up with the relevant information placed in its corresponding chapter. Feedback on the IV management and storage systems were placed in their respective chapters, while infuser feedback is discussed below).



low profile infuser



rounded shell infuser

The infuser – Concept Feedback

All participants reacted positively to both the rounded shell infuser and the low-profile infuser concepts (*Figure 54.*). They felt very optimistic about moving towards an ergonomic shape for the infuser and thought that using an IV reservoir that could be removed without tools was a good idea to ensure that the infuser could be easily dismantled for recycling. Furthermore, both patient-participants reacted particularly positively to the lower profile infuser. Although they preferred the threaded IV control point, the slim design and more 'elegant' shape were preferred. Based on these discussions, I decided to refine the slim-fitting IV infuser shell form with a threaded IV control point.

Although not specific to the infuser, I was surprised by how important aesthetics were to both patient participants. The infuser would spend most of its time inside a bag that would be worn under clothing. As a result, I assumed that ergonomics would be a bigger concern for participants than aesthetics. However, both patient participants highlighted the 'elegant' slim aesthetic of the low profile infuser as a critical element of why they preferred it over the rounded shell infuser. This opened my thinking around the infuser more. Up until this point, I had largely only considered the infuser as a functional and ergonomic product, but I realised that there was more space to explore how aesthetics could play a role in the patient experience of the infuser and the other elements of the system. As a functional element, it was also mentioned by one participant that the low profile infuser would likely be easier to insert into the bag as the thinner edges would likely make for a smoother fit. The fit of the infuser in the bag was not an area I had considered as much until this comment was made. As a result, I decided to explore further how the infuser storage bag and the infuser could function more effectively together to ensure the two systems worked cohesively.

Ideation Based on the Second Expert Critique

Based on the second critique, it was clear that the aesthetics and functions I was exploring were aligned with the preferences of the expert user. I decided to focus on keeping the elegant infuser form and low profile with an easily removable, threaded IV outlet. I started to refine my ideas using a mood board to initiate the following stages of the design process.

Mood board images removed for copyright reasons.

Figure 55. A mood board to explore the aesthetics and material choice for the research outcome. Based on the expert critiques, a more elegant and minimal design language was preferred over a more traditional medical aesthetics. I decided to use a minimalist approach to materials and form language. Minimalism involved using simple colours and form, which avoided embellishment and only features necessary elements of the design (Obendorf, 2009).

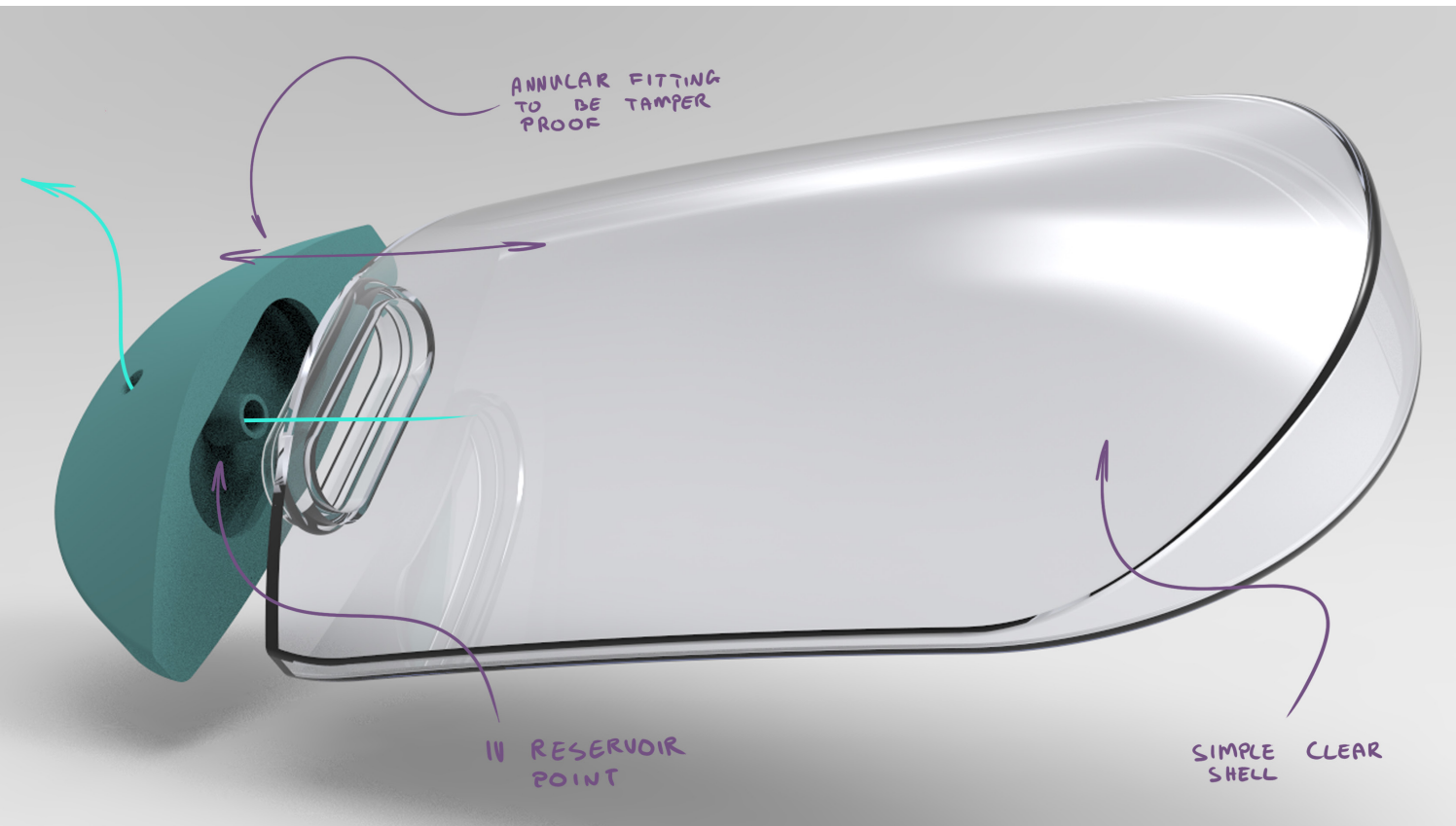


Figure 56. Further CAD exploration based on the second phase of expert critiques. Exploration of an annular fitting style infuser. Although using a threaded system made the parts easier to dismantle, I felt user-tested was needed for both a threaded IV reservoir and a press-fit system.

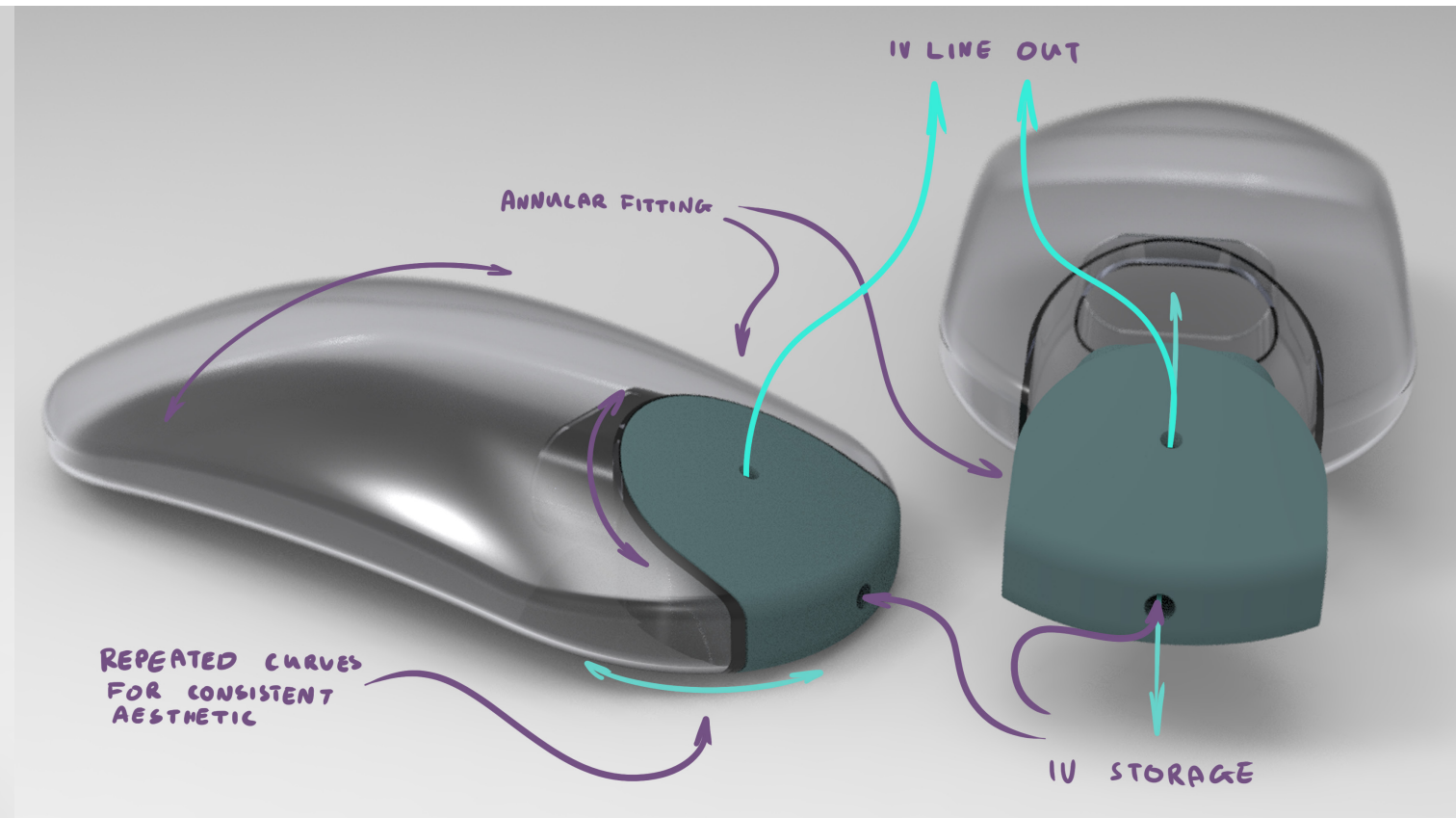


Figure 57. Building on the previous concept, this version features a more refined shell form based on earlier sketches.

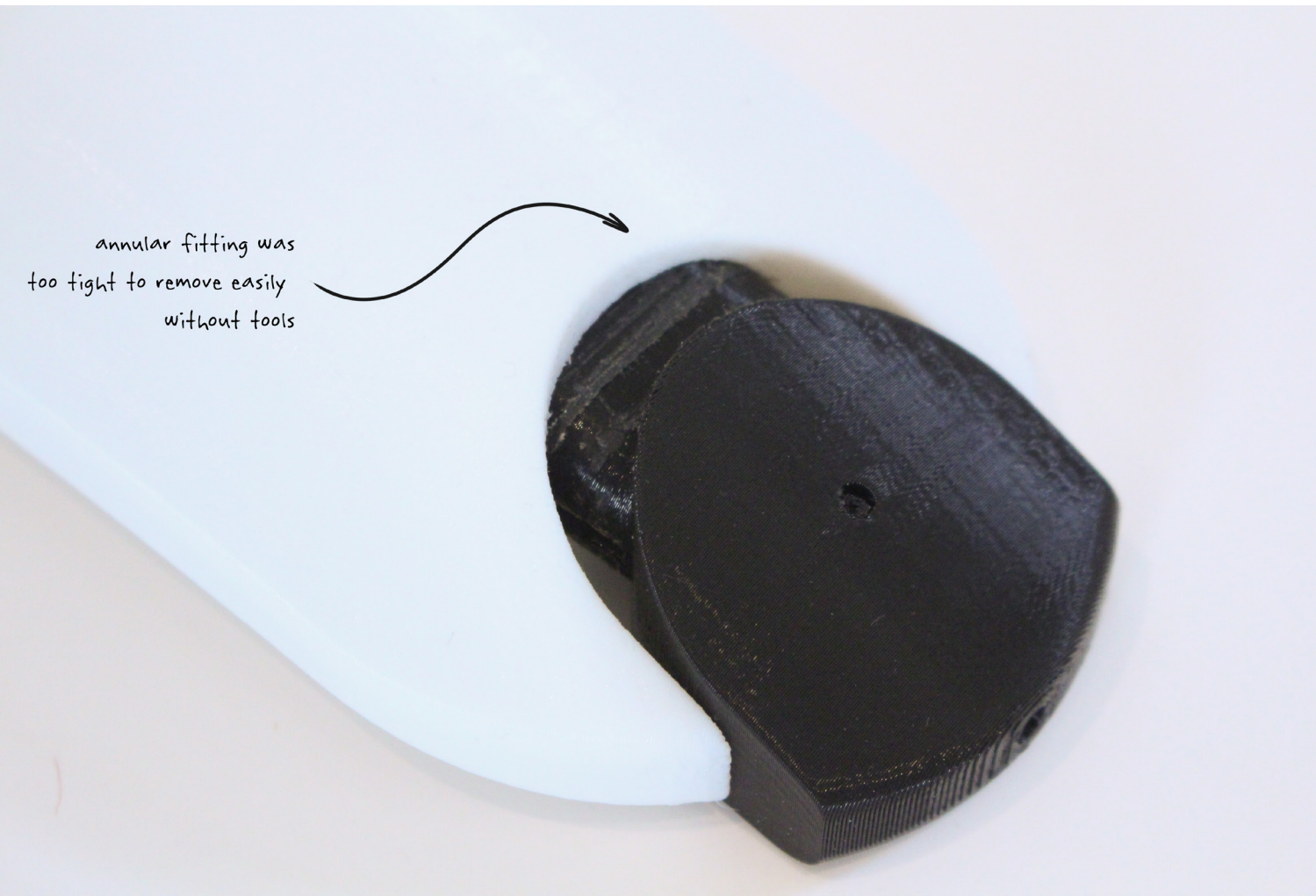


Figure 58. In testing, I found that although the press fit system worked, it was still too hard to get this to fit tightly enough to remain secure but easily removable. Based on this testing, I decided to move back towards exploring the use of a threaded IV reservoir fitting.

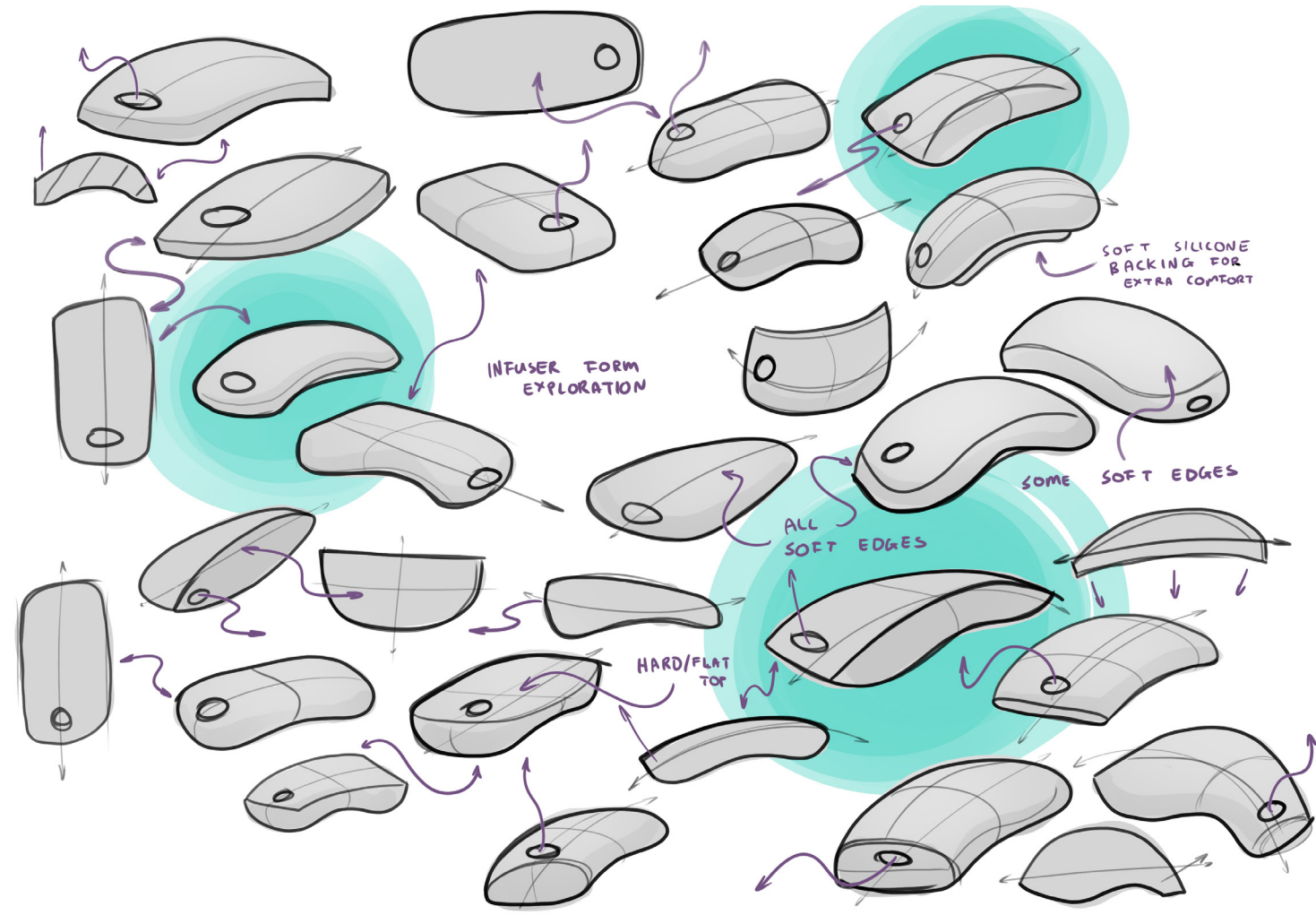
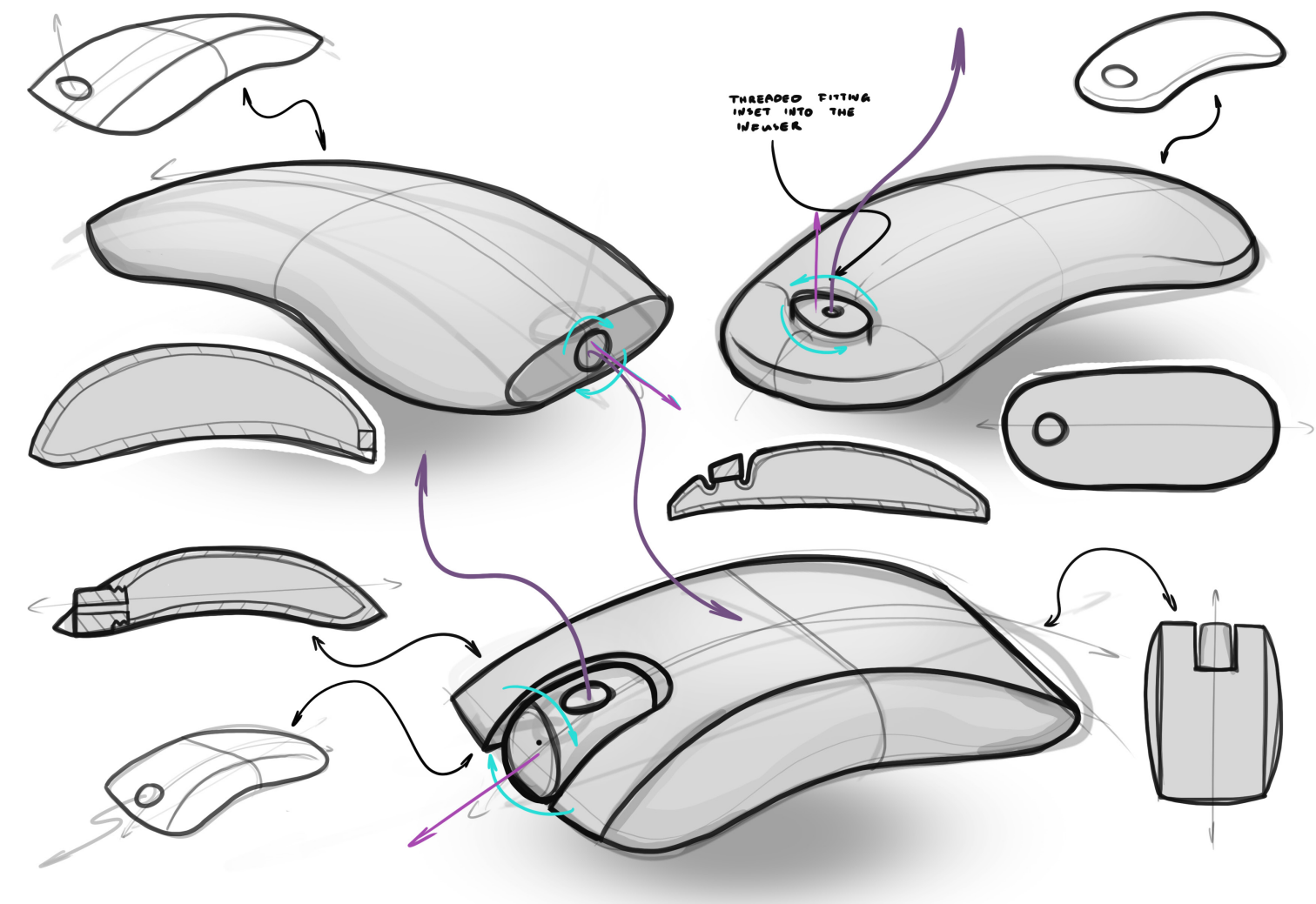


Figure 59. Early exploration sketches for the form of the infuser. Building on the prior CAD modelling and prototyping, I started to explore more concepts focused on a low profile and ergonomic shape. The most successful concepts were highlighted. The infusers were selected based on the criteria defined in the refined design brief and which designs I felt were the most interesting and had the potential for development.



Each concept explored an elegant ergonomic form with a threaded IV reservoir. The curve that contacted the body (the concave side) was the same across every design. This curve was based on the average ergonomic circumference of the waist (Understanding Excess Body Weight: New Zealand Health Survey, 2015). However, the outer circumference had to balance the volume of the infuser with the contact patch (Derby et al., 2006). A larger footprint (contact patch with the user's body) meant a thinner infuser, resulting in a slimmer fit. However, this could also lead to possible overheating or pressure points for the user. To find the most appropriate balance between these two elements, each design was explored further with CAD modelling to both finalise the ergonomic elements and the functional elements of the infusers.

Figure 60. These sketches show exploration of the three most successful IV infuser concepts from the previous exploration sketches. I used these sketches to explore three different placements for the infuser IV line outlet and the shape of the shell. Although I had decided to focus on using a threaded IV outlet, I wanted to explore different concepts for the orientation of this outlet.

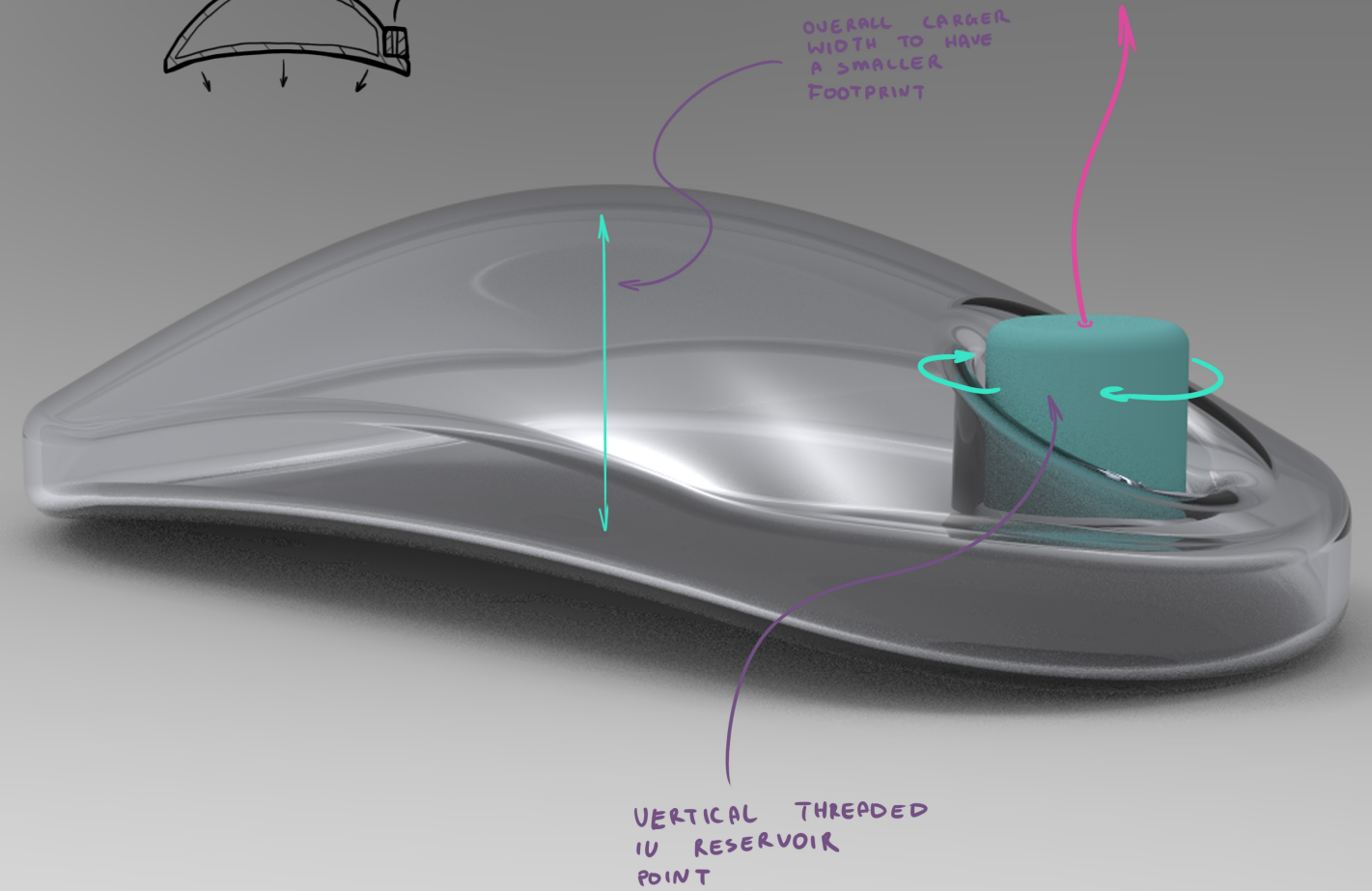
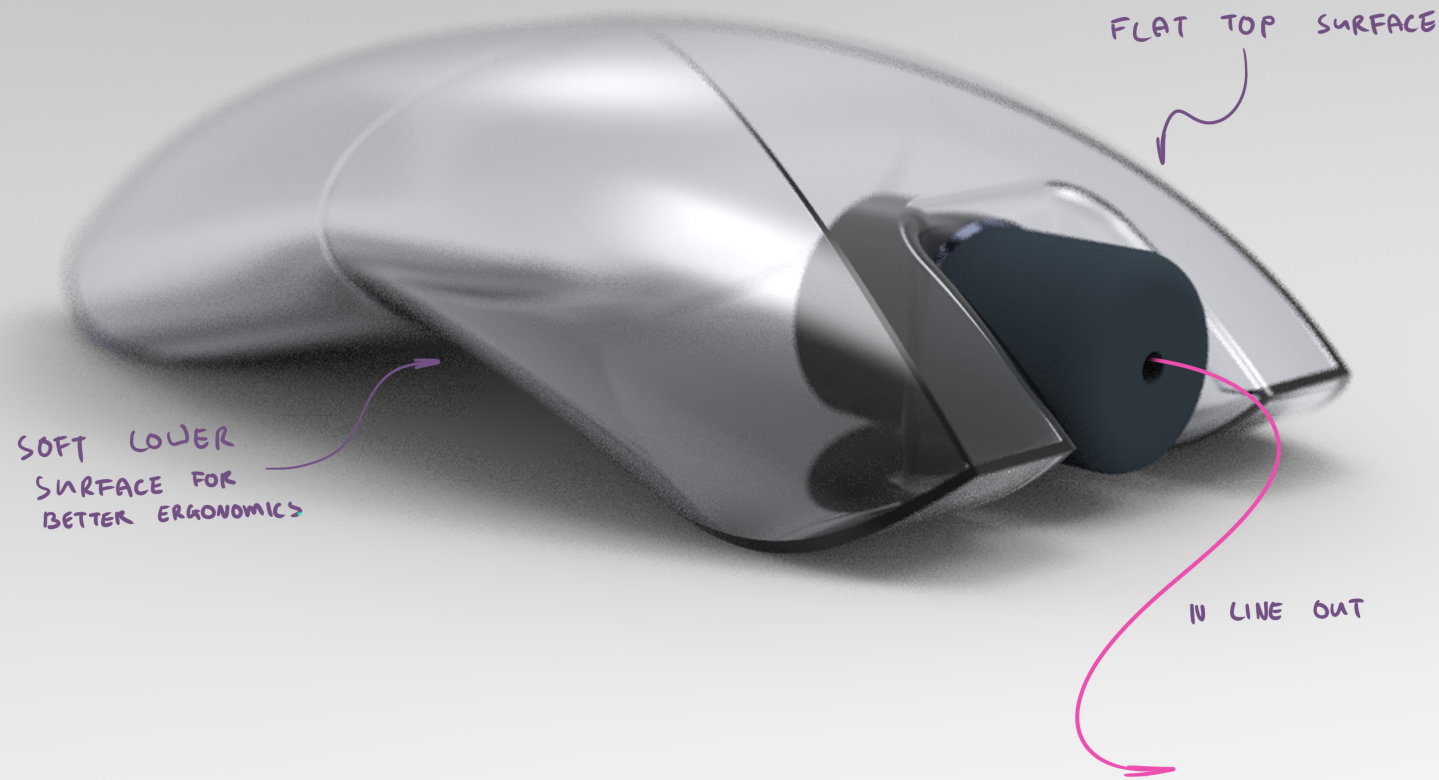
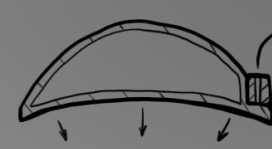
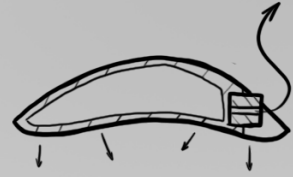
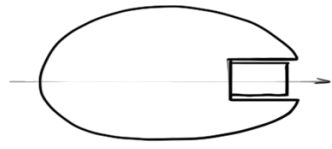
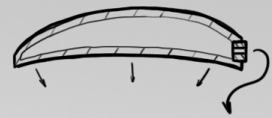
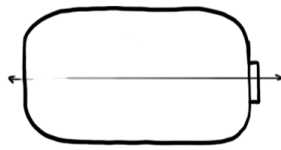


Figure 61. Horizontal and inset reservoir control point. This version featured a more exposed IV control point to allow for easier unthreading after use than concepts two and three.

Figure 62. This concept featured a vertically oriented threaded inset IV reservoir with a thicker width to avoid a larger contact patch on the patient.



THINNER WIDTH
TO BE LOWER
PROFILE

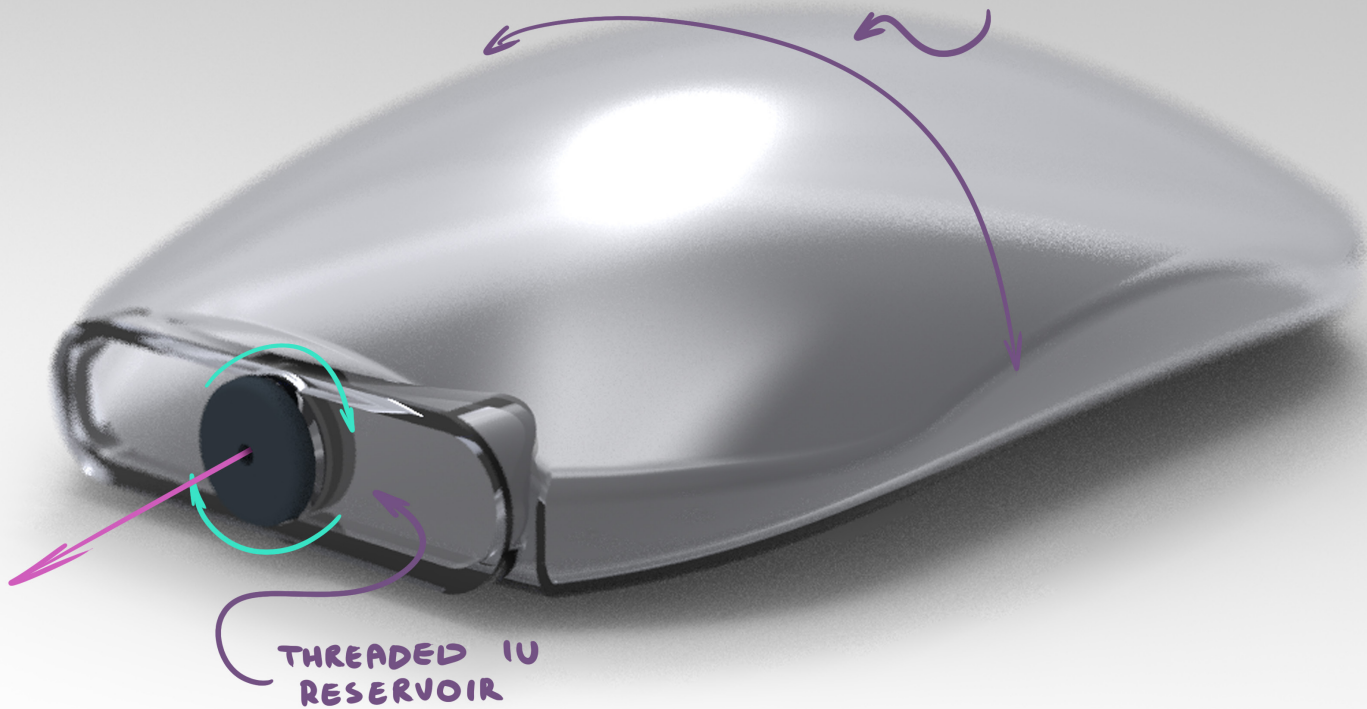
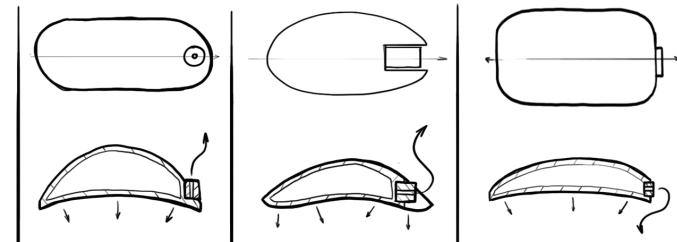


Figure 63. A horizontal threaded infuser with a thinner overall width and a larger footprint.



fit against body	5	6	7
easy infuser changes	8	6	6
low profile	5	7	9
fit on different bodies	6	7	7
infuser line position	9	6	6
production cost	6	5	8
	39	40	43

Figure 64. Infuser concepts evaluation matrix. The three most successful infusers were rated in relation to the requirements for the infuser set out in the design brief. Based on these ratings and prototype testing, I found that the function and overall shape of infuser concept three were the most successful.

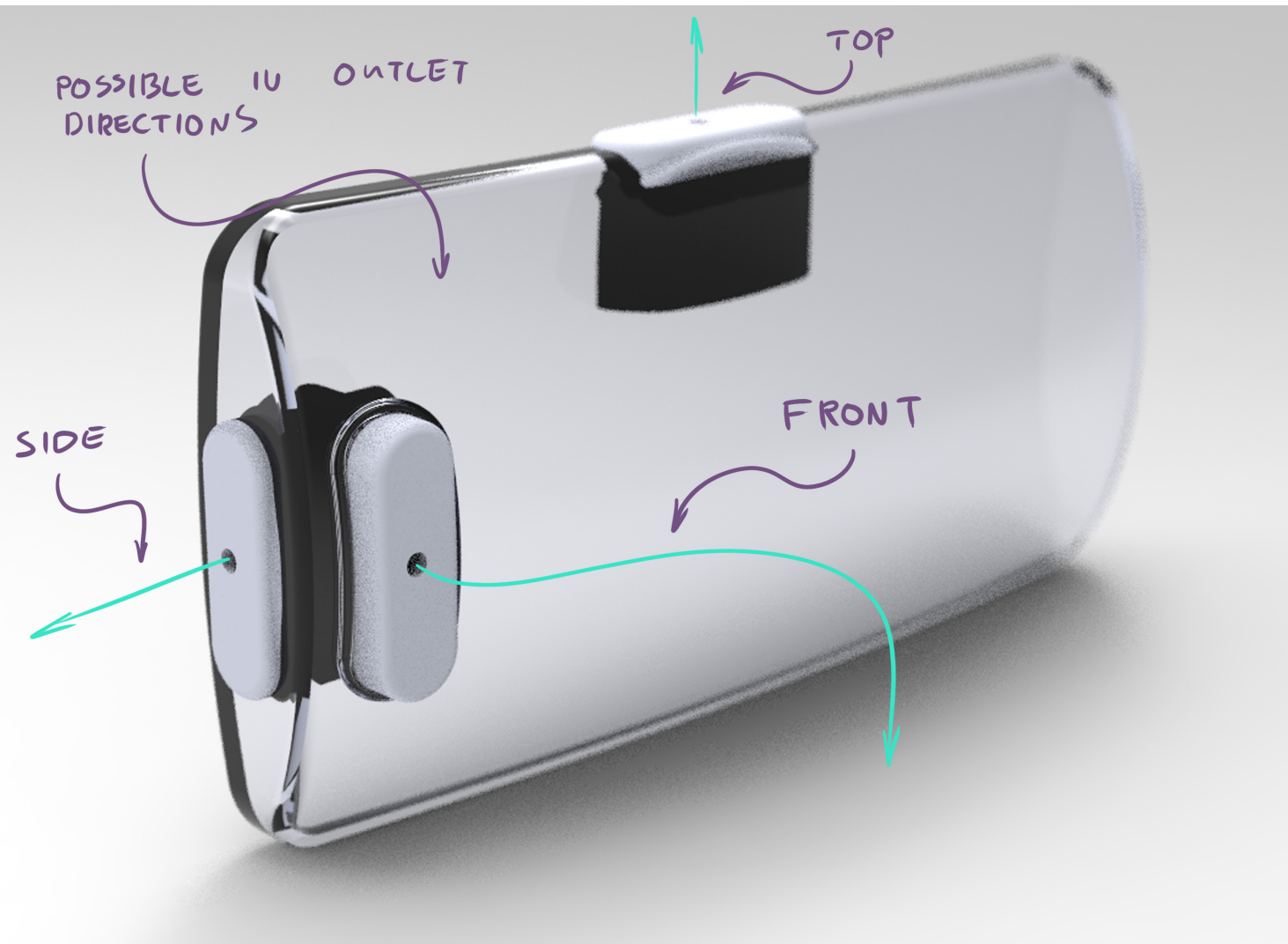


Figure 65. Diagram showing possible IV outlet directions.

Upon testing with the infuser storage bag, I found that the infuser needed to have the IV-line outlet on the side of the device to be the most functionally appropriate. Although there were benefits to having the outlet on the front, such as laying the device flat for infuser changes, the IV line needed to bend back on itself under the users' clothing, creating unnecessary bulk to the overall system and risking damage to the IV line. In addition, the relatively high pressure used in elastomeric reservoirs may make it difficult to fill the reservoir if the balloon was oriented at 90 degrees to the IV outlet direction (on top of the infuser) (Baxter, 2017; Patro et al., 2016).

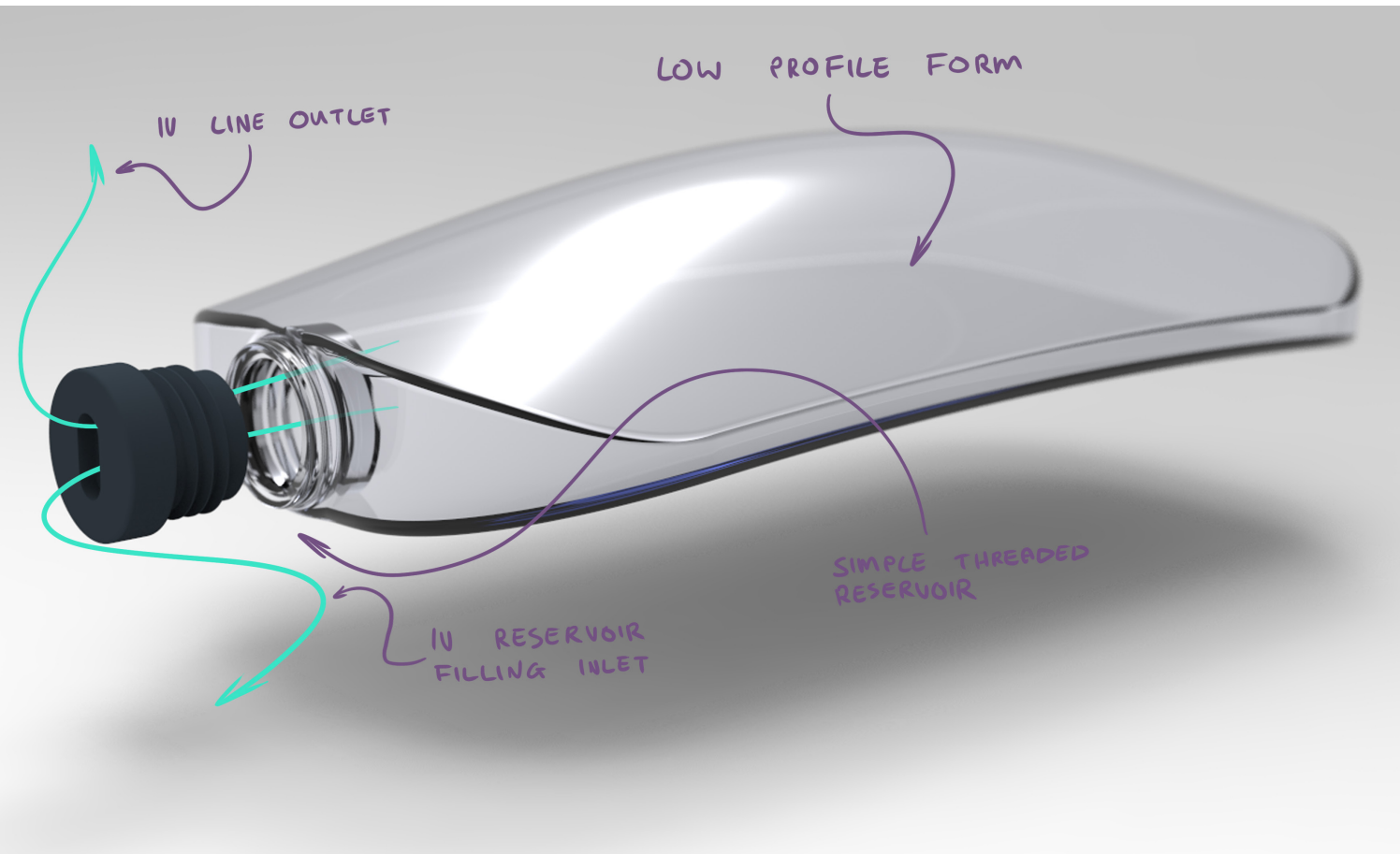


Figure 66. Finalised CAD exploration. This design featured an IV control point that used a simple threaded system. This threaded cap would feature a tamperproof seal to ensure patients could unthread and dispose of the internal elements before recycling the shell. The tamperproof seal would help avoid this occurring before the infuser was empty.

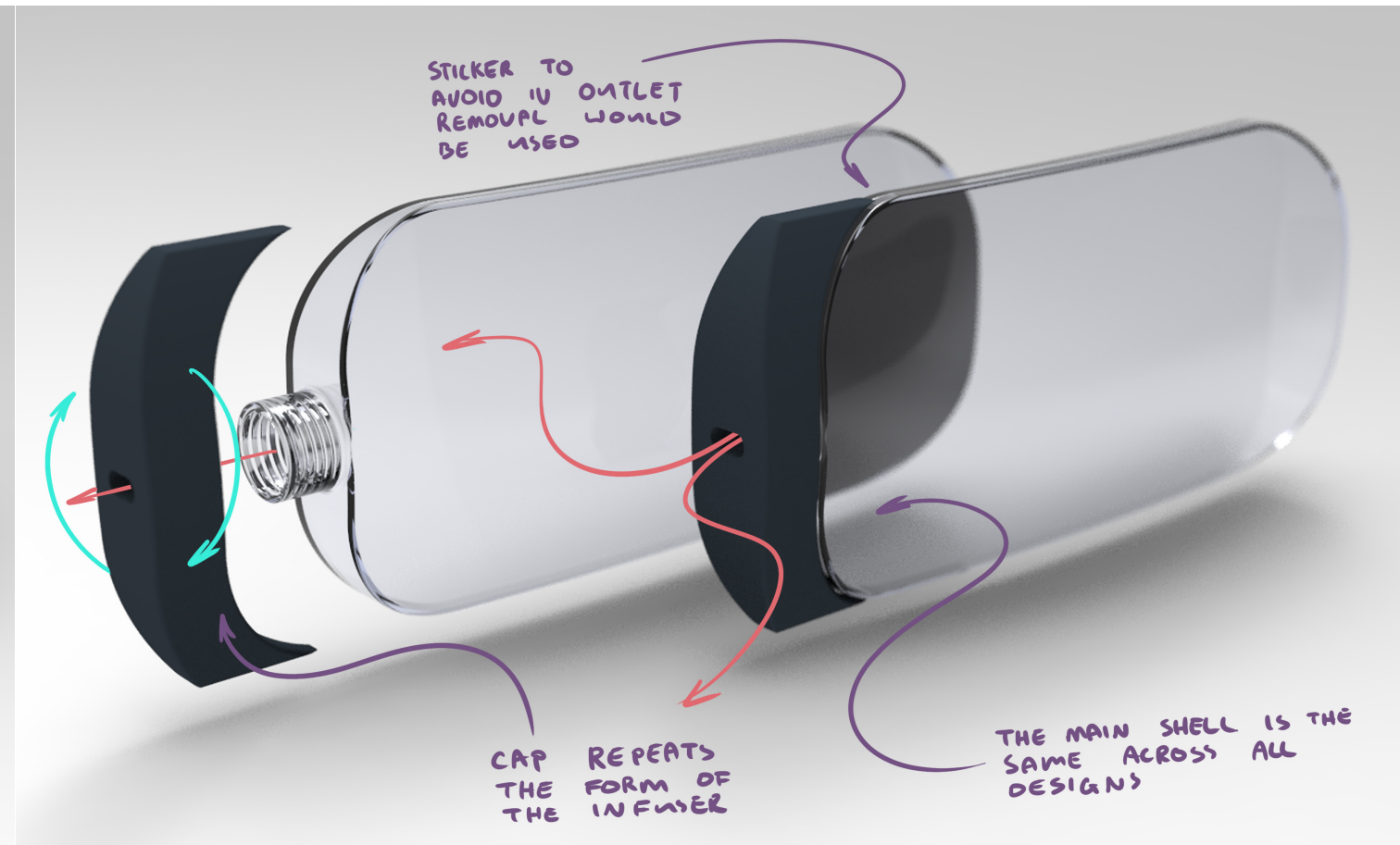


Figure 67. Although the first concept featured an external cap, this would need to be made longer to accommodate the limitations of the blow moulding process (a preform is used which requires a neck) (Hassan et al., 2019; Schmidt et al., 1998). As a result, to avoid a visible 'neck' being added to the shell, which may detract from the overall aesthetic, I wanted to explore a cap that shrouded the infuser shell.

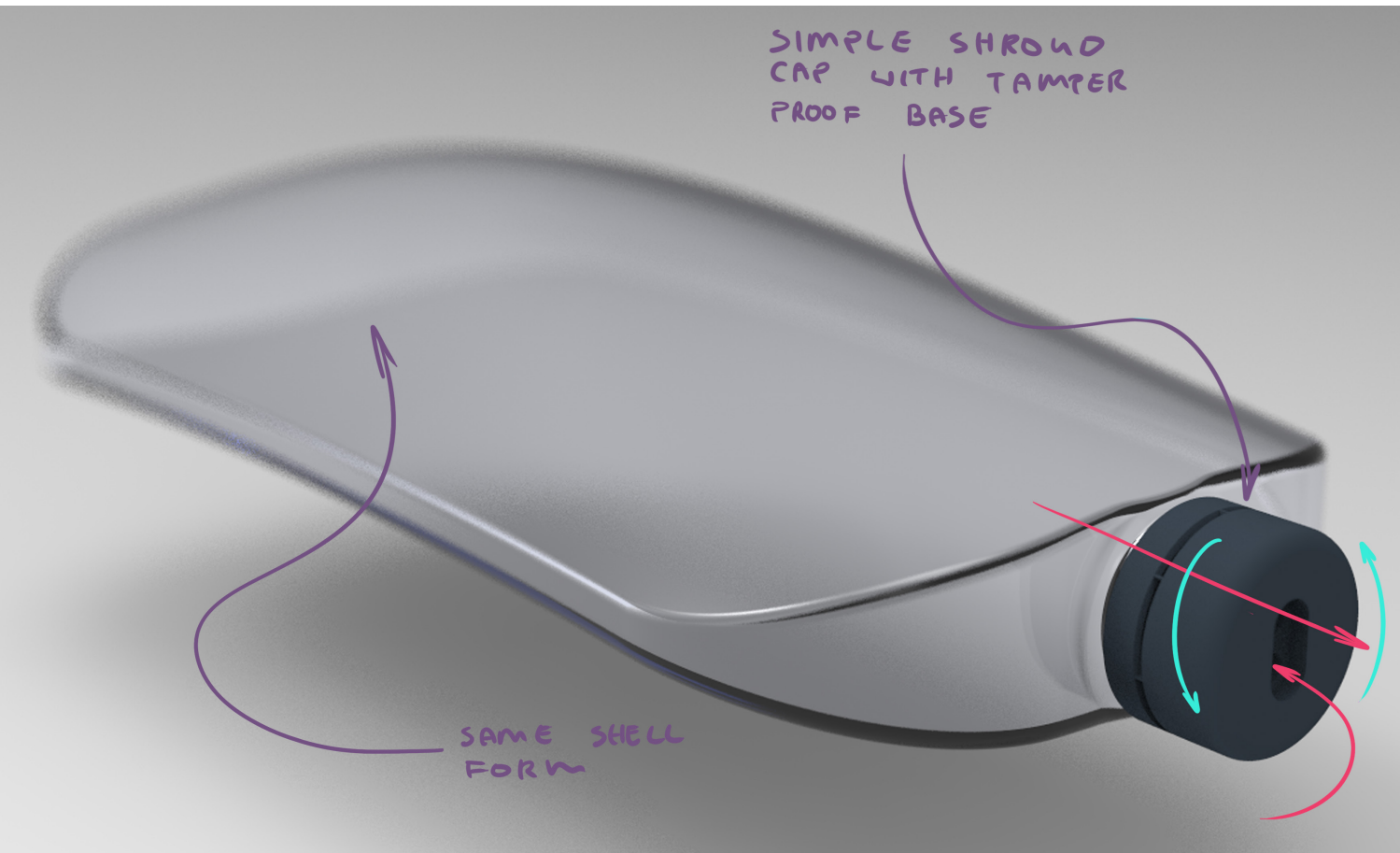


Figure 68. This version featured the same cap design as the first concept, with a slightly longer neck as required by the limitations of blow moulding.

Each concept was presented to the (previous patient) expert user for a final expert critique session to explore their feedback on the concepts. These mainly focused on the design of the infuser cap (the shroud versus the cap with a visible neck). However, the main infuser shell was also presented as a basis for discussion around the shape of the shell.

Third Expert Critique

Expert User

The final expert critique session was completed with the expert user participant. This session involved presenting the most successful concepts and using these as a basis for critiques. Questions were mainly focused on the aesthetic appeal of each design and perspectives on the functional elements.

As with the second phase of expert critiques, this expert critique has been broken up through each chapter where applicable. This section only discusses the infuser.

For the infuser, the participant felt that an adhesive label (seal) would be clear enough to show the device should not be disassembled during use as opposed to a soft drink style cap tamper-proof seal. They also preferred the shrouded infuser concept due to its more elegant form. The only other preference the participant expressed was the inclusion of a larger radius on the edges of the infuser shell to ensure it was comfortable to wear and would not create pressure points during use. The participant felt that both aesthetic directions for the caps and the infuser were successful and significantly improved the existing system.

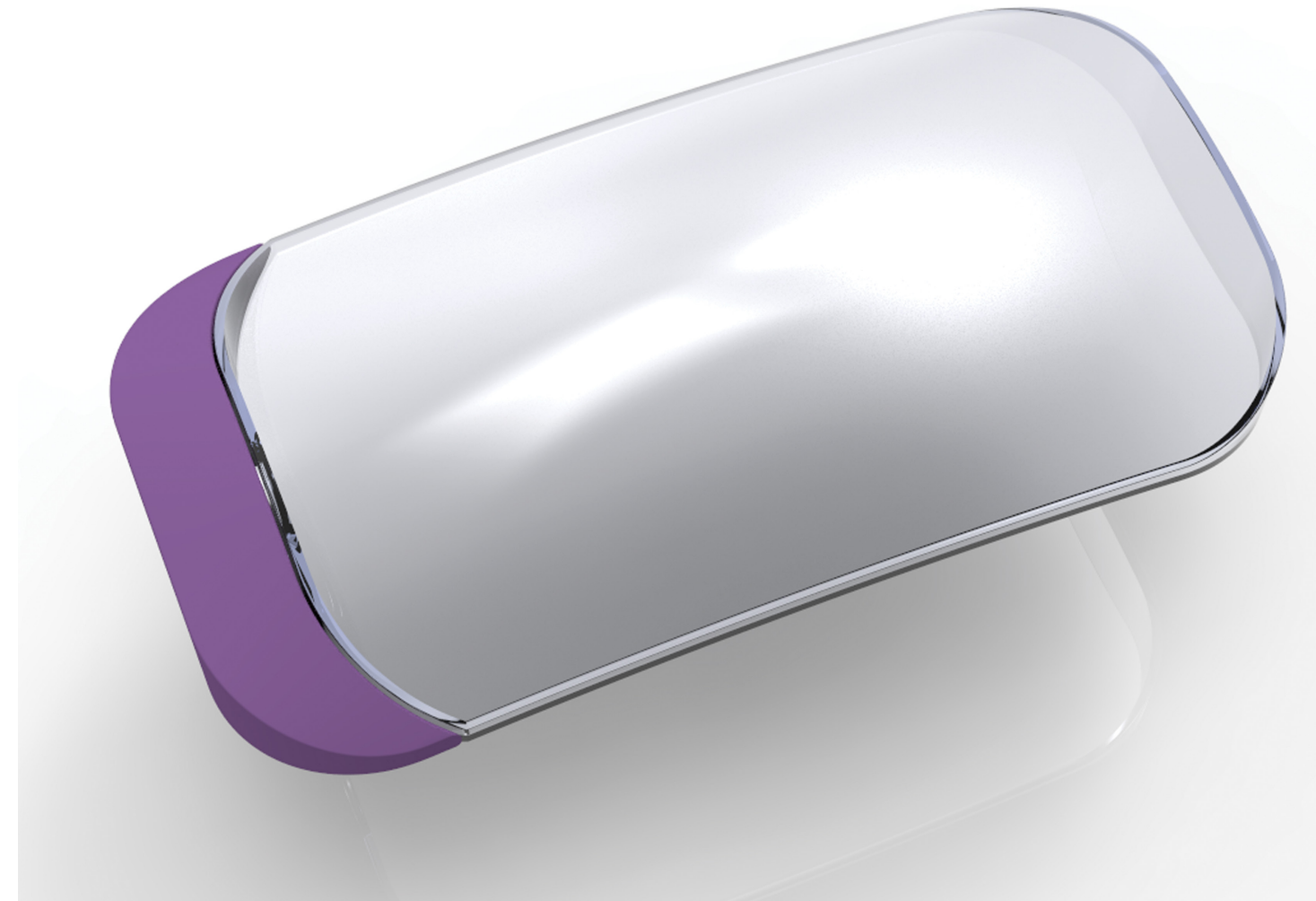


Figure 69. The final form of the infuser shifted to reflect the third expert critique.

Branding and Manufacturing Considerations

Following the final expert critique, I adjusted the form of the infuser to reflect the user's insights and perspectives on the previous concepts. The expert user preferred the more contemporary look of the second infuser concept. The inclusion of a shroud to cover the infuser shell's neck also helped the infuser fit better in the storage bag. A bottle cap style outlet could use a built-in seal like a soft drink bottle. However, for the shroud style cap, I wanted to explore an adhesive label seal that could be placed over the top of the device by a pharmacist after the device was filled. This label would display branding and patient information. In addition, the label would help ensure that the patient knew the IV-line outlet (cap) should not be unscrewed until after use (Johnston, 2003). As previously discussed, this concept was brought up with the expert user who reacted positively to the use of an adhesive label/seal.

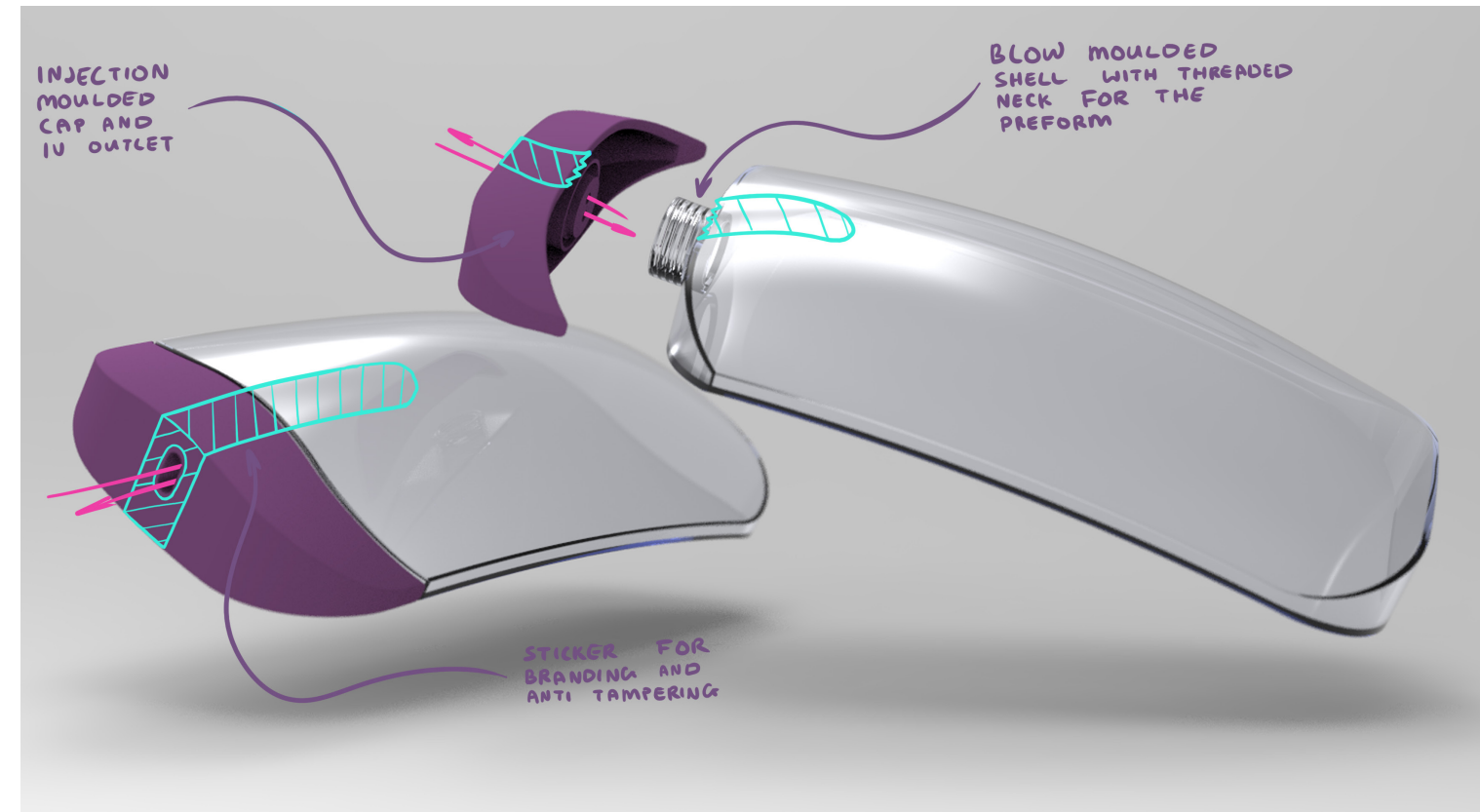


Figure 70. Exploration of the size and placement of a combined adhesive seal and label for patient information.

Infuser Communication Material Exploration

As with the existing infuser, my design needed to display the infuser's information (flow rate, capacity, etc.) and the patient information (drug name, dosage, etc.). Plastic with large, screen-printed icons can be difficult to recycle because of ink bleeding during the recycling process (Gecol et al., 2002). Ink bleed can be avoided through more complex screen printing methods. However, these can make the manufacturing process more expensive (Gecol et al., 2003; "KHS cuts packaging with direct printing on PET bottles, adhesive multi-packs", 2015). As a result, I decided to keep screen printing on the infuser shell to a minimum and place most of the information on a label. In addition, labels were generally considered to be more cost-effective (Stewart, 2016).

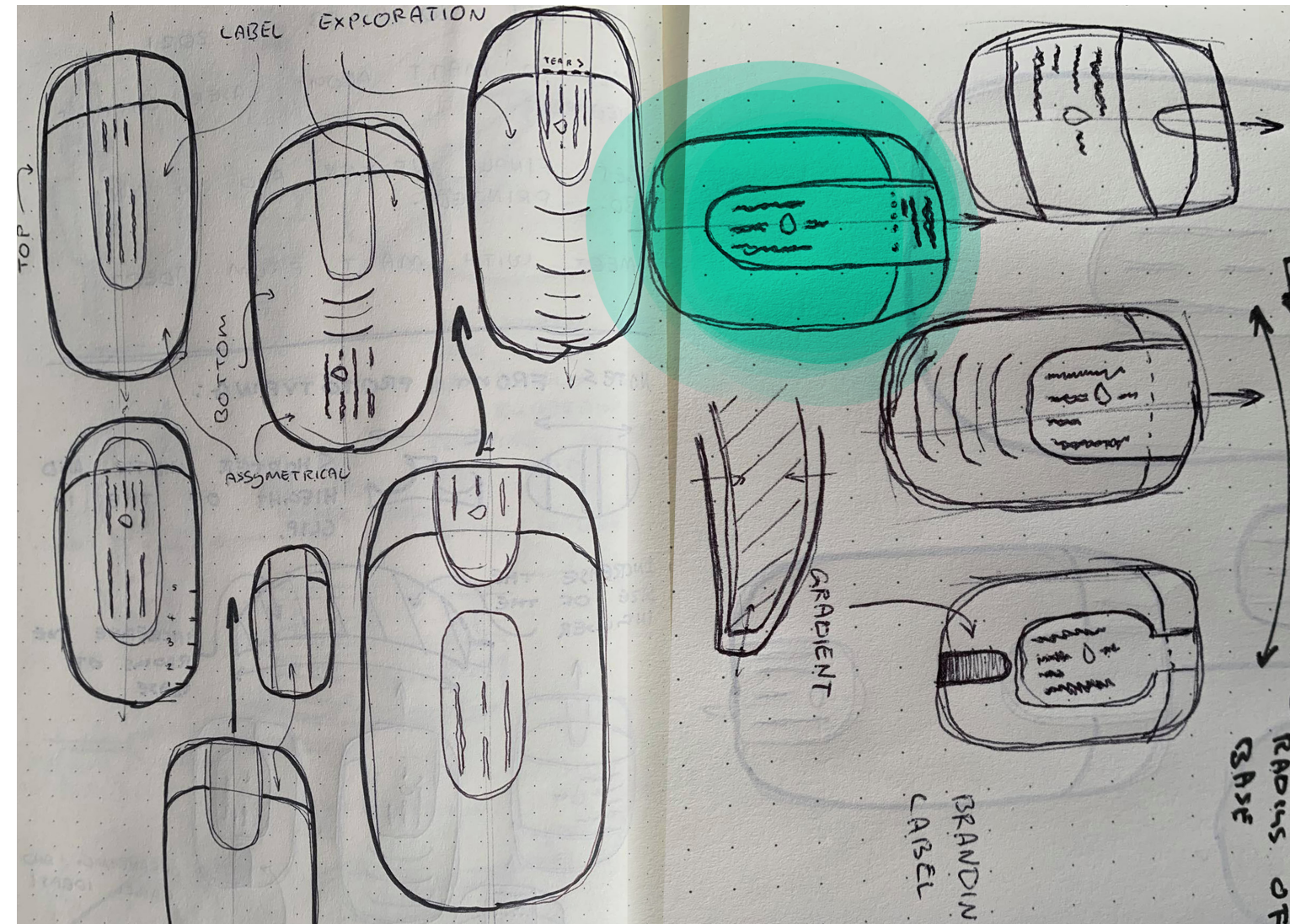


Figure 71. Exploration of possible layouts for the label. The highlighted option was selected based on its aesthetic appeal and less complex design.



Figure 72. Rapid prototype of the final infuser concept featuring the location and size of the adhesive seal along with finalised dimensions for the infuser's form.

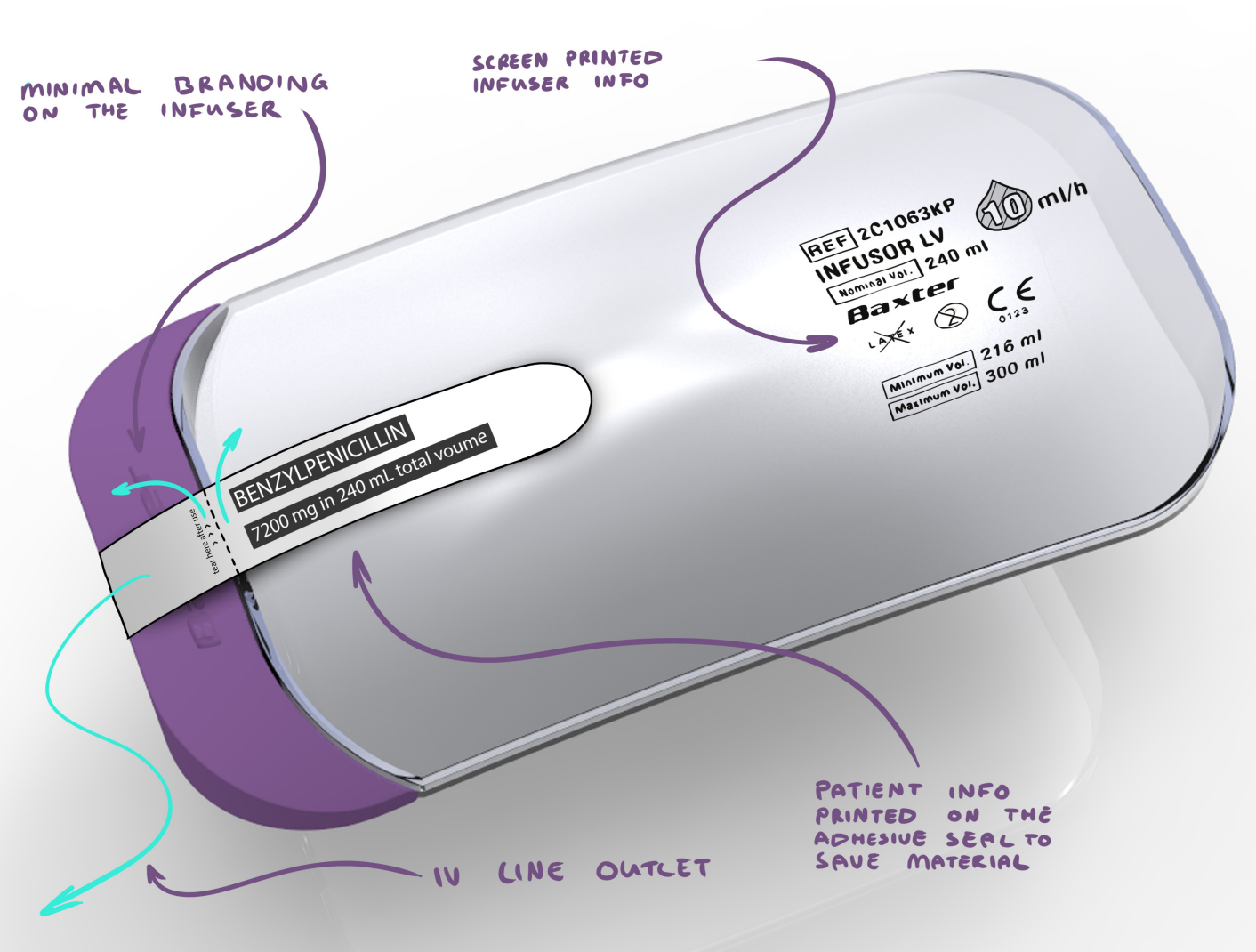


Figure 73. This concept used a thinner label with minimal information to keep the overall system minimal. The branding on the infuser was kept simple and effective while maintaining the elegance of the system. Based on the existing infuser, I felt like this design would not provide patients with enough information or meet the hospital's requirements.

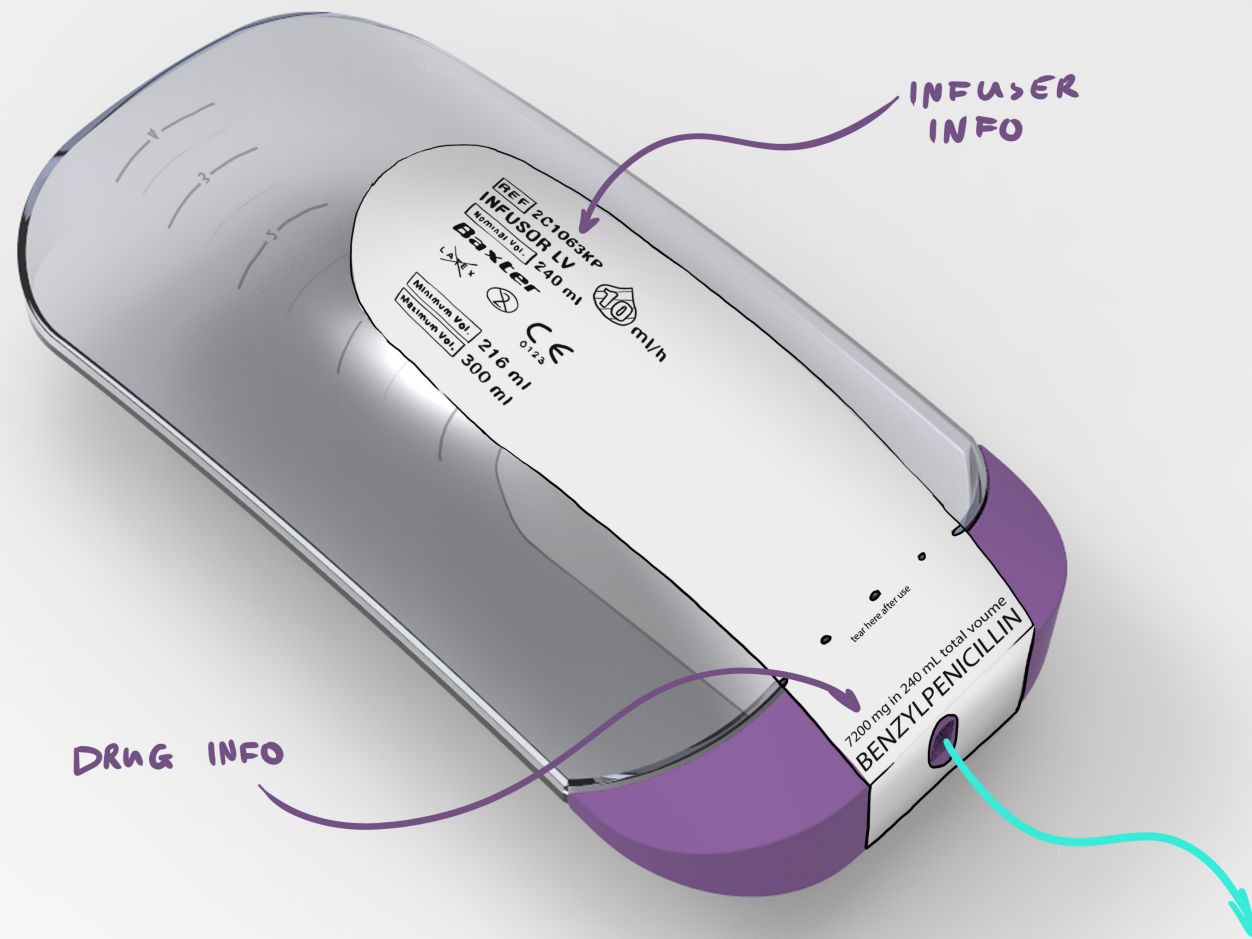


Figure 74. This concept featured a larger overall label that allowed for more information to be directly printed on the label rather than the bottle itself.

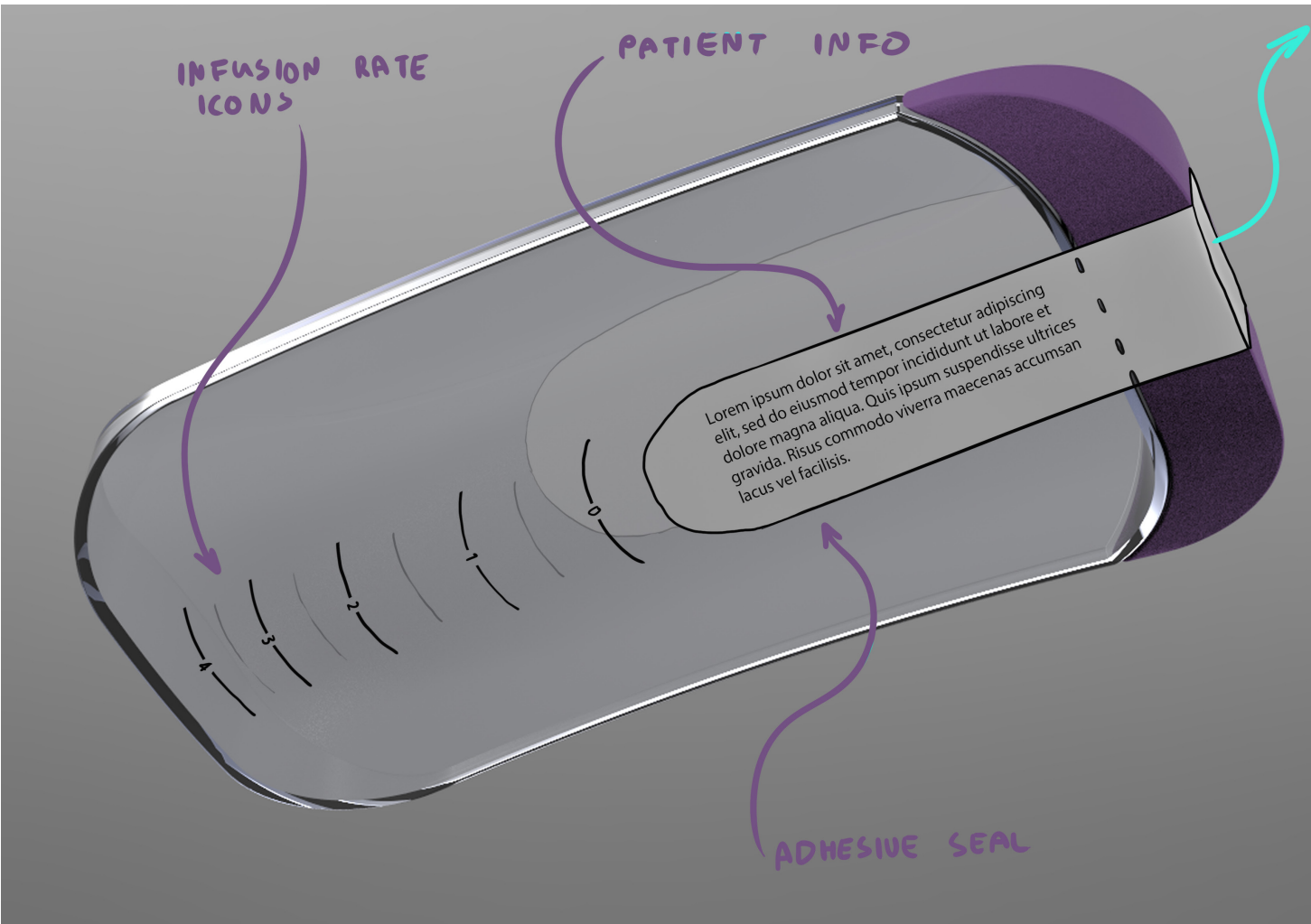


Figure 75. The concept used the same style of indicator to show the infusion rate as the existing Baxter infuser; this was very clearly visible but would add to the screen-printing volume required on the infuser.

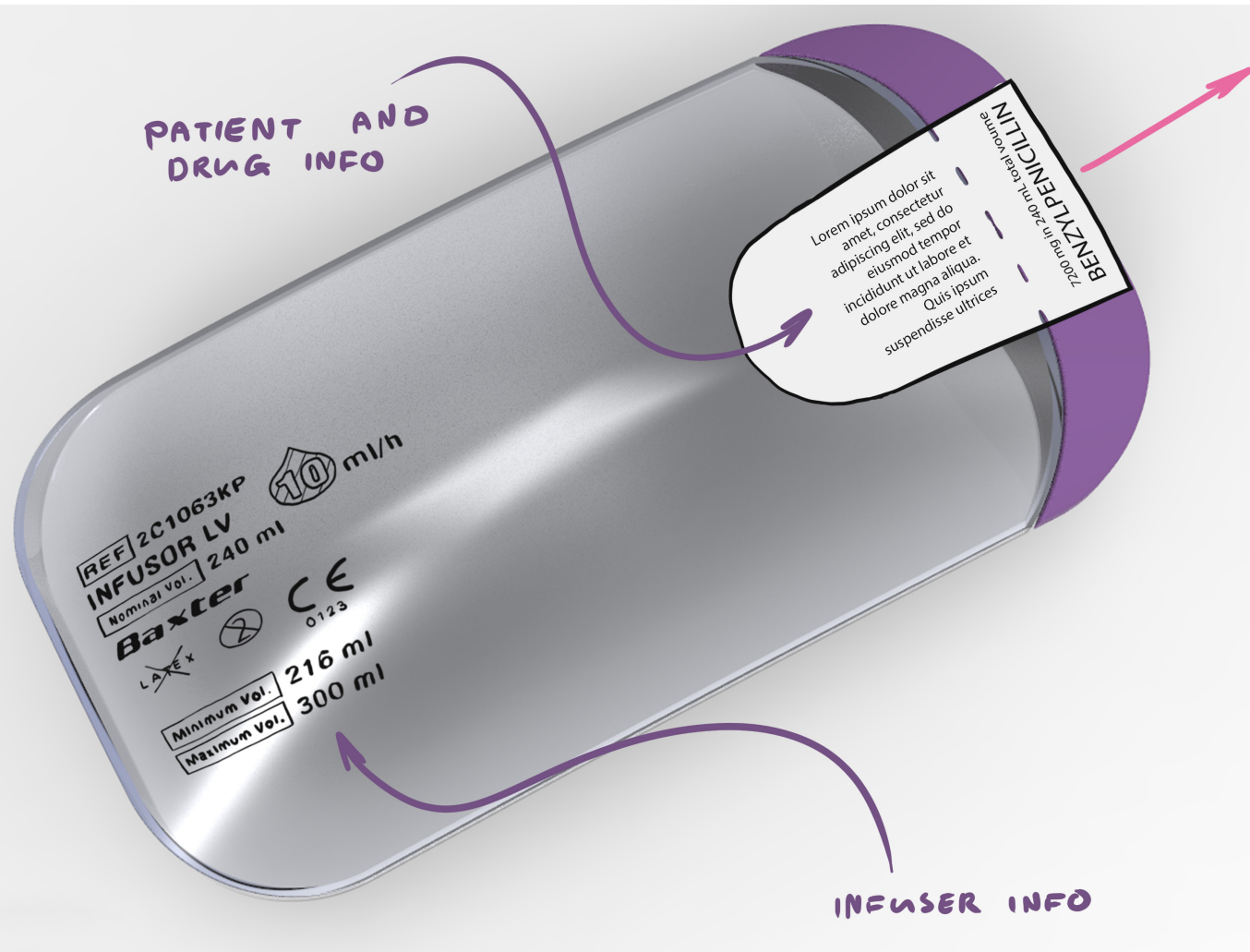


Figure 76. This concept featured a smaller label with only the necessary patient and drug information. The decision in this design was made to screen print the infuser information directly onto the infuser body, as was the case with the existing infuser.

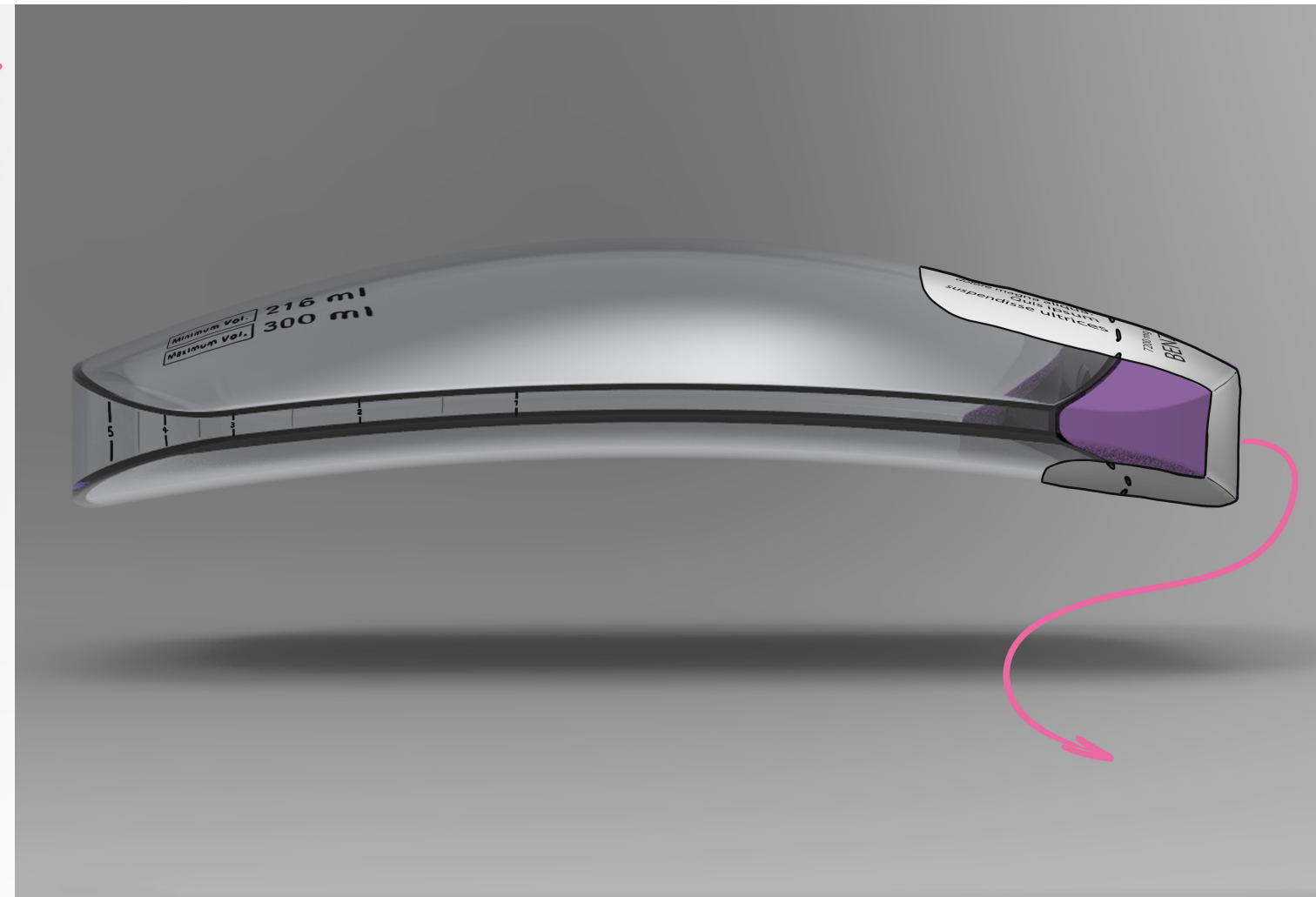


Figure 77. This concept also used a simple indicator on the side of the device to show the rate of infusion to minimise the amount of screen printing on the infuser. The smaller icons still provide patients with clear information while keeping ink on the infuser shell to a minimum.

The focus of these branding elements was to keep the system minimal and easily understandable. Bearing this in mind, I decided that the third concept was the most successful. The third concept used an adhesive label with enough space to display all the drug and patient information without excess material being used. By keeping the information on the infuser the same as the existing Baxter infuser, this concept also allowed for the current manufacturing process to remain essentially unchanged. The label would be printed by the distribution pharmacy, as was the practice with the OPIVA service at the time of the research case.

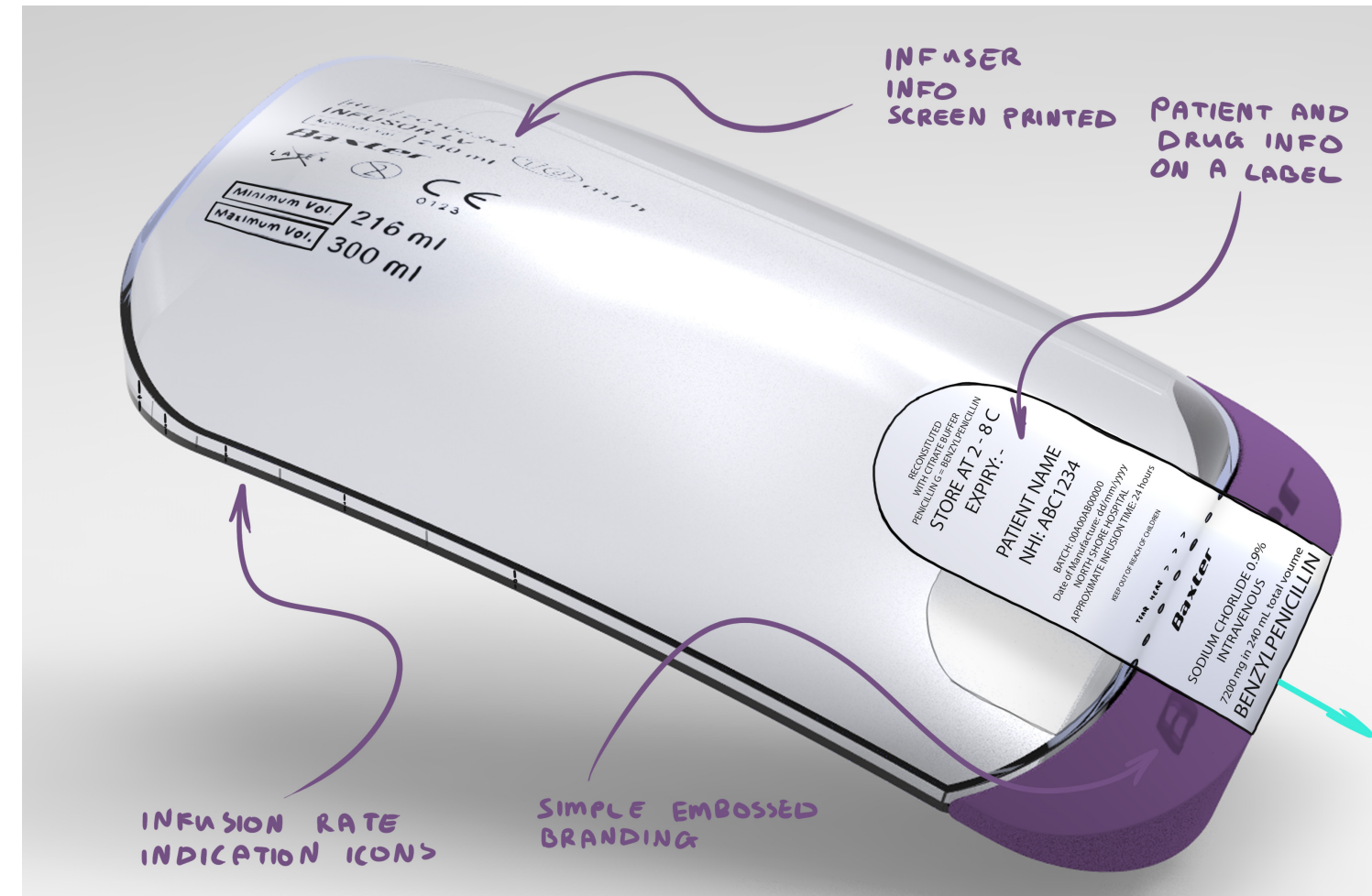


Figure 78. Final label size and branding icons. Patient information and the specific drug information was printed on a removable label which that doubled as an adhesive seal. Infuser information would be screen printed on the infuser, ensuring important information could not accidentally be removed while maximising the recyclability of the whole system by avoiding excess ink on the plastic (Gecol et al., 2003; Gecol et al., 2002).

Information Hierarchy

One important element of communication design is the hierarchy of information (Coates & Ellison, 2014). Storage of the infusers was key to avoiding the perishing of the antibiotics; therefore, I decided this should be on top of the label with the specific drug mixture at the bottom of the label. This order was selected as participants did not express concern about the drug mixture. The hierarchy matched current recommendations on information hierarchy in medical packaging and labels (Jaenichen, 2017).



Figure 79. Final infuser CAD model with finalised branding and labelling.

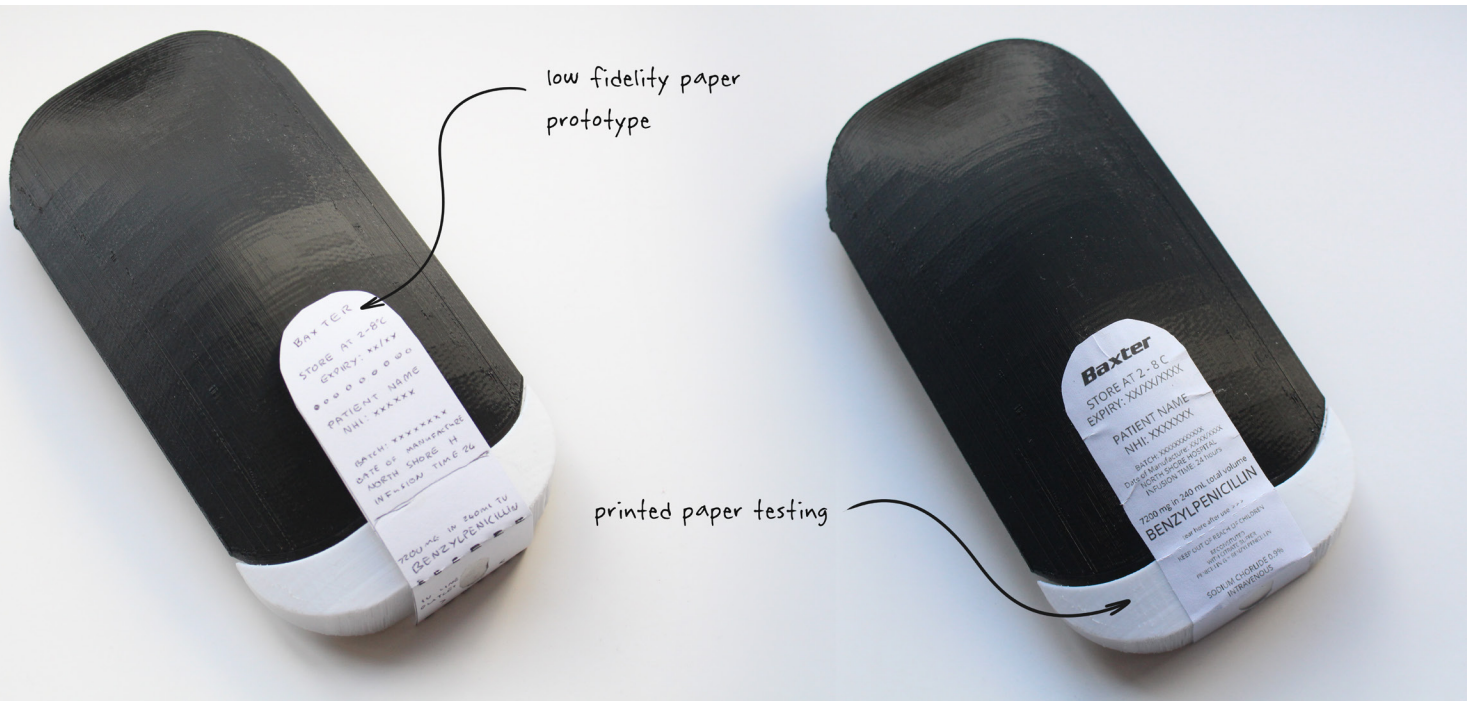


Figure 80. Final infuser CAD model with finalised branding and labelling.

Infuser Materiality and Production Considerations

When considering the materiality of the system, I wanted to focus on sustainability while ensuring the system remained cost-effective. Considering production methods that ensure the infuser can be produced as cost-effectively as possible was important as the infusers were disposed of every day. The average patient would use 42 – 56 infusers during treatment. The purple IV outlet and cap would be assembled from several injection moulded parts. The infuser shell would be blow moulded from PETE, and the cap would be injection moulded from HDPE. Future research could explore the applicability of more sustainable plastics such as high-density polyethene and thermoplastic starch (HDPE-TPS). HDPE-TPS produces up to 80% less greenhouse gas emissions in production than traditional polyethene plastics (Anderson, 2012). The elements that allow the IV outlet to function would remain the same as the existing Baxter infuser in both function and materiality. This IV line remained unchanged from the existing Baxter infuser with a vinyl IV line; injection moulded HDPE flow restrictor with a glass capillary to control the flow.



Figure 81. The finalised infuser (CAD model).

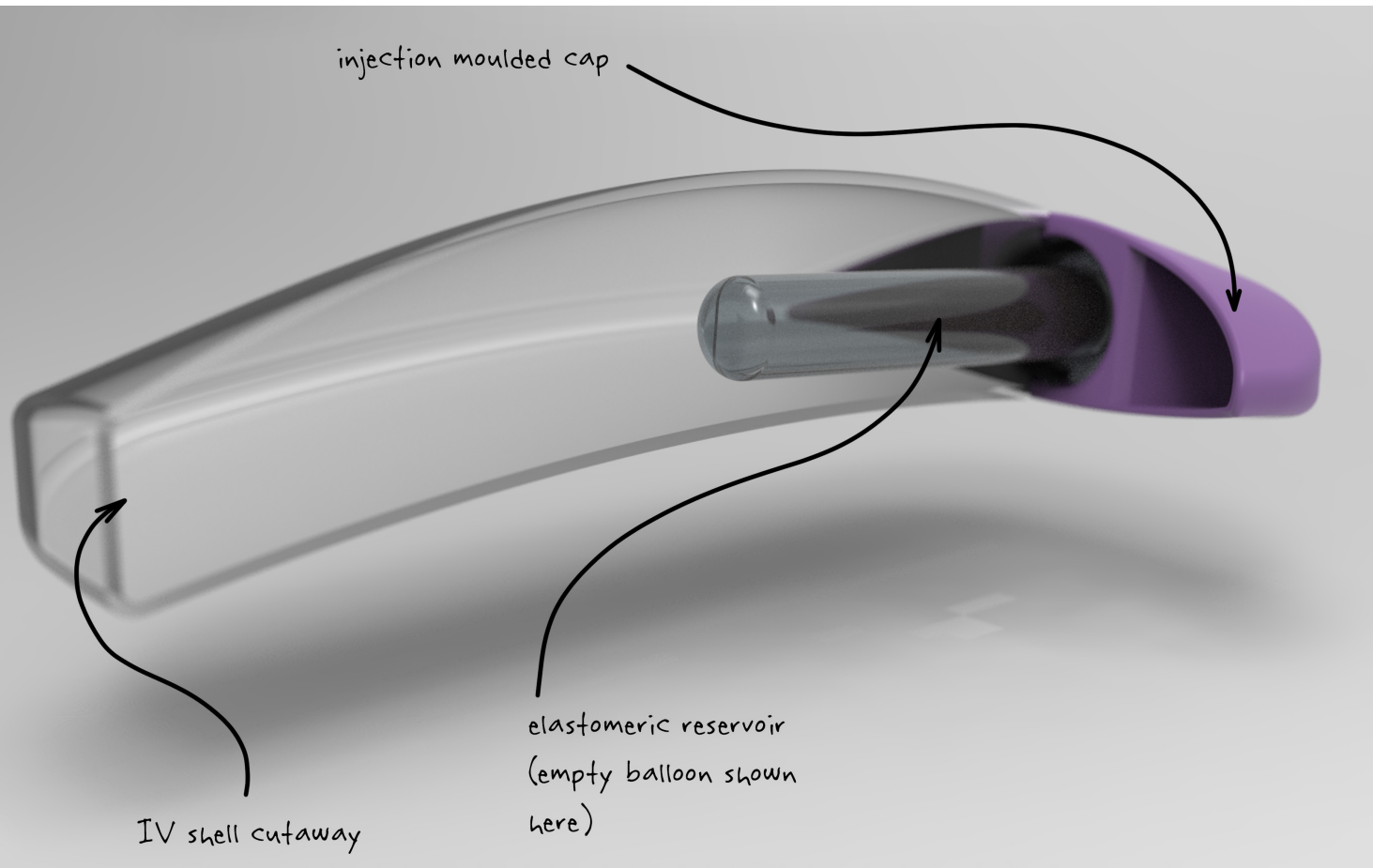


Figure 82. Cutaway highlighting the position and size of the elastomeric balloon and internal details of the infuser cap.

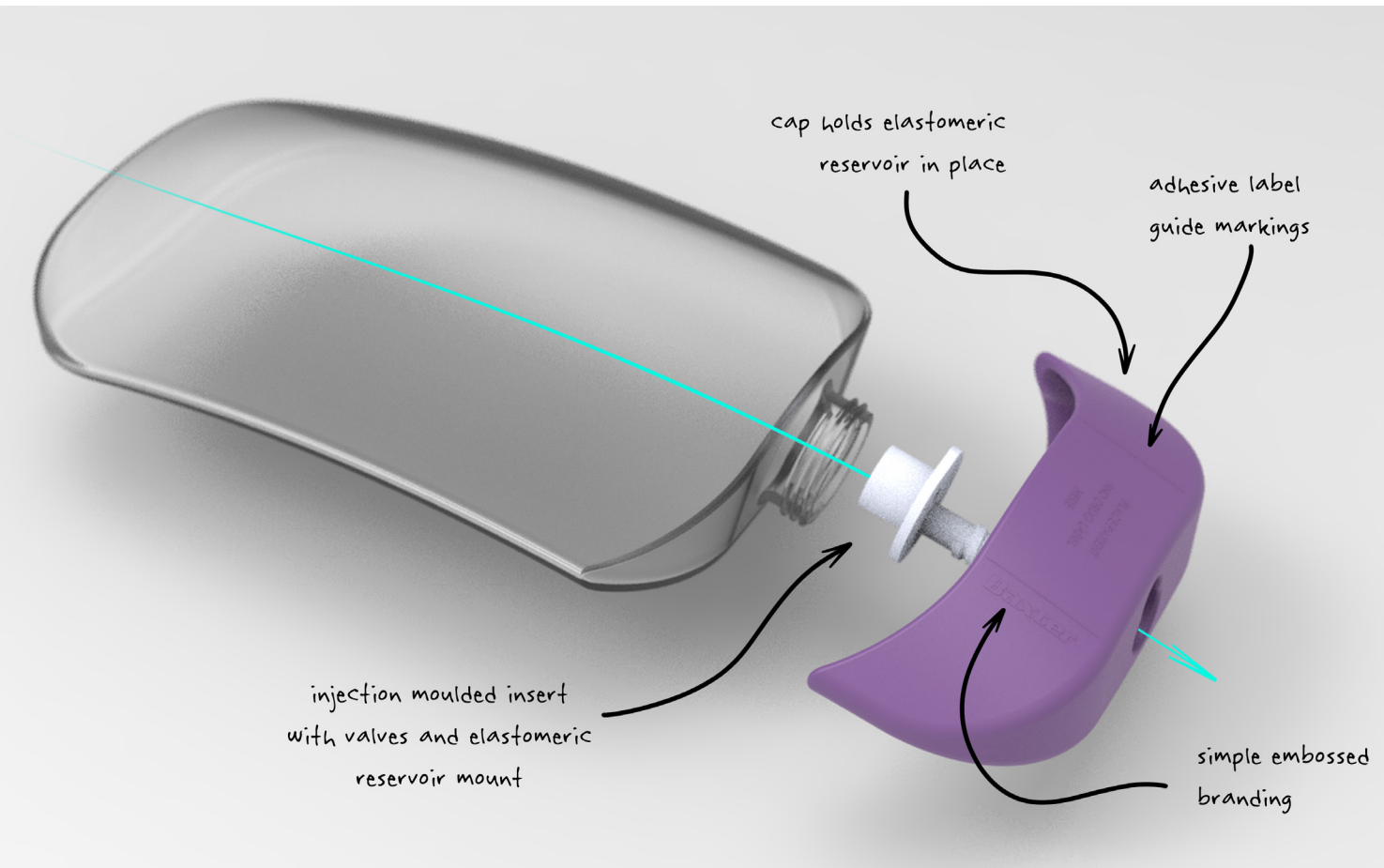


Figure 83. Exploded view of the final infuser design. The infuser cap design featured embossed branding and label guidelines. A separate insert for the elastomeric balloon and IV outlet was also added. This part allowed the infuser cap and shell to be recycled, while the only parts which would need to be disposed of were the elastomeric balloon and small IV outlet. This small IV outlet part maximises the sustainability of the whole system.

The Infuser Storage System - Further Refinement

Following exploration of the infuser, the next step was to consider the design of the infuser storage bag. I decided that the infuser storage system (waist bag) should operate cohesively with the infuser.

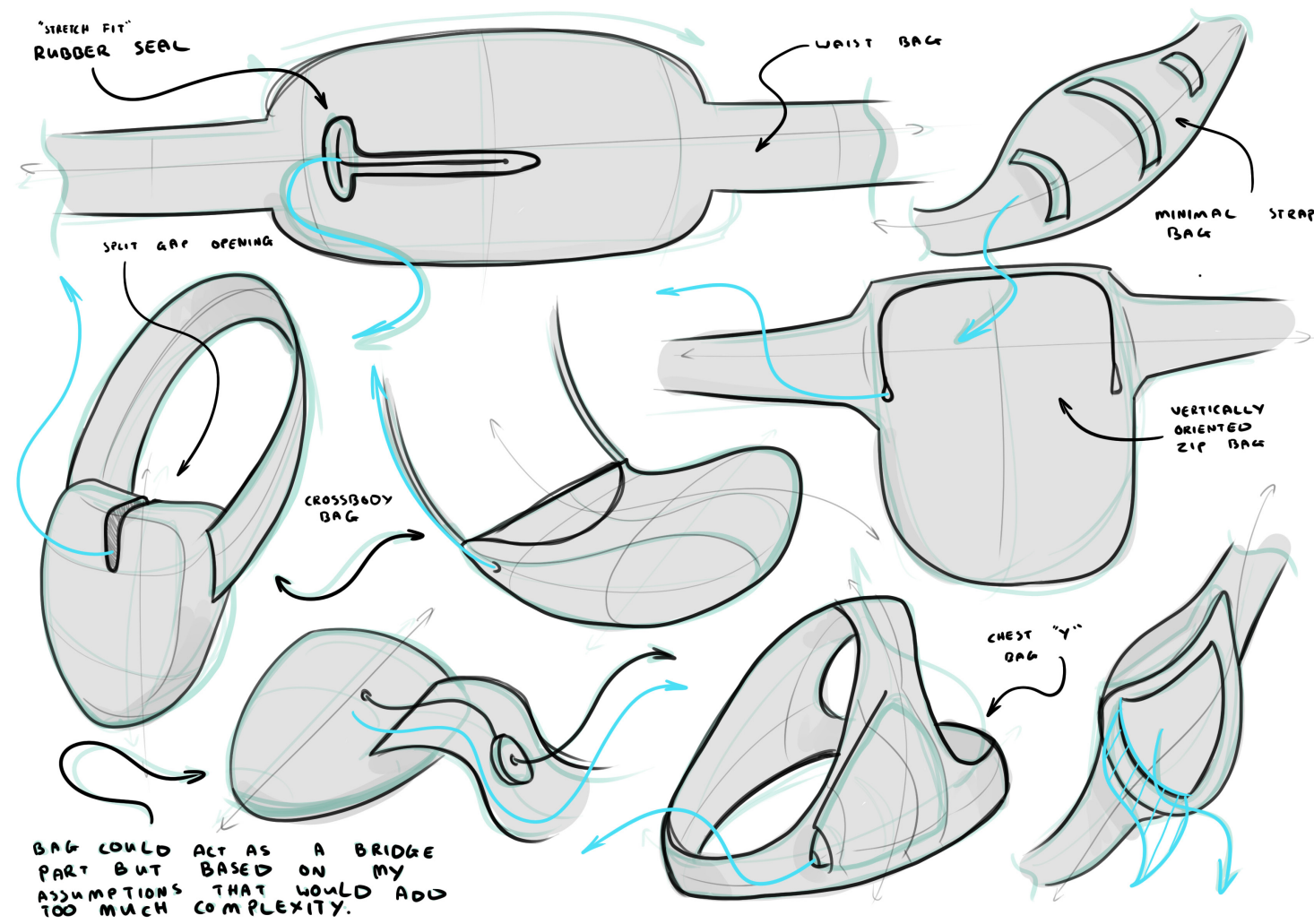


Figure 84. Initial infuser bag concepts. Various bag shapes can be comfortably worn throughout the day. In these sketches, I explored three; messenger bags, crossbody bags and 'bum' bags. Each concept featured various methods of running the IV line out of the bag to examine how this system might work in practice.

The bag needed to be simple and easy to use, easily removed for sleeping and showering while being secure during day-to-day activities. Although most participants liked the ergonomics of the existing waist bag, I still wanted to explore a crossbody bag. Although these could be used to run the IV up the body for a more secure fit, the strap could present issues for people with breasts and cause overheating when worn under clothing.

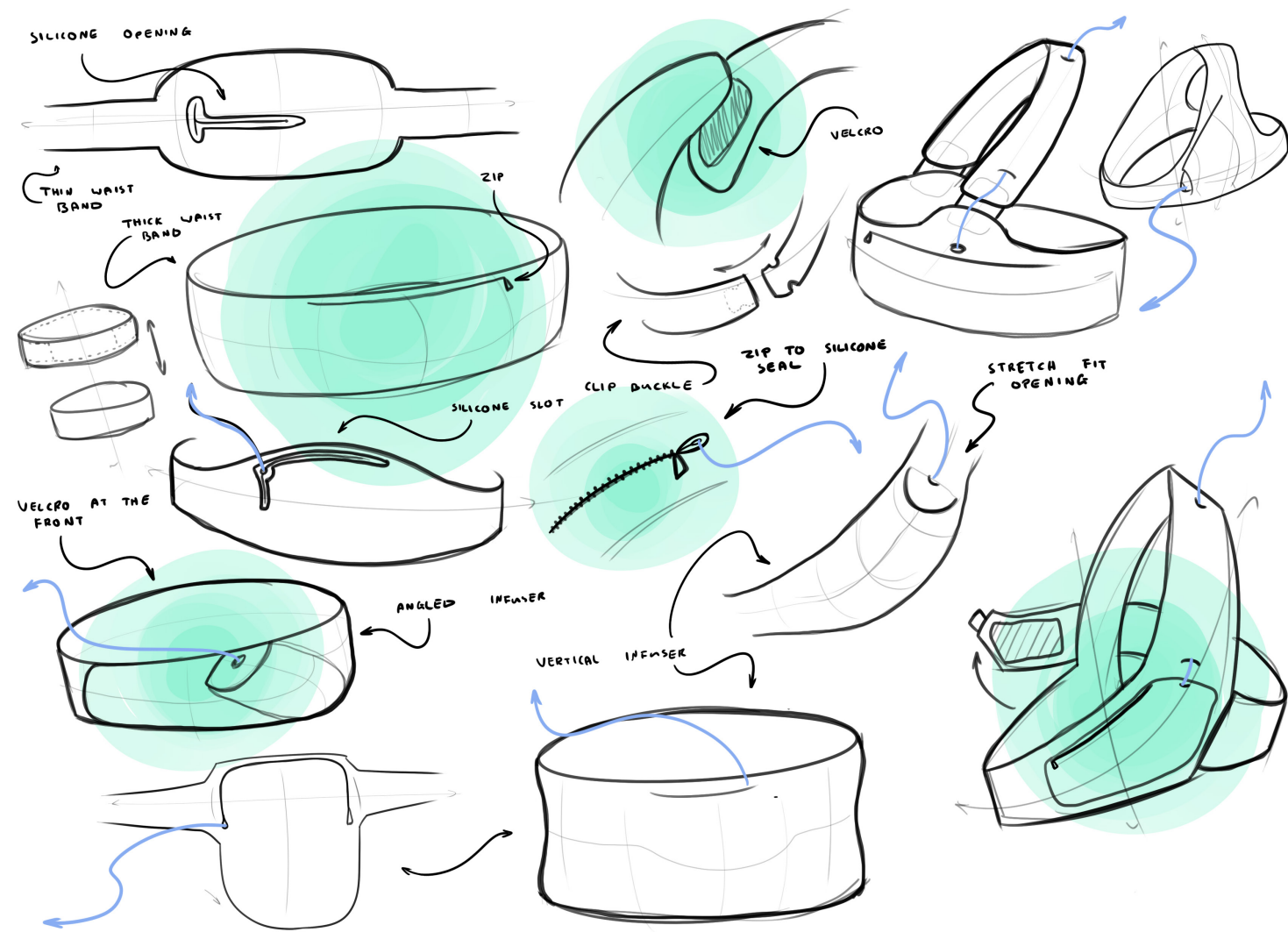
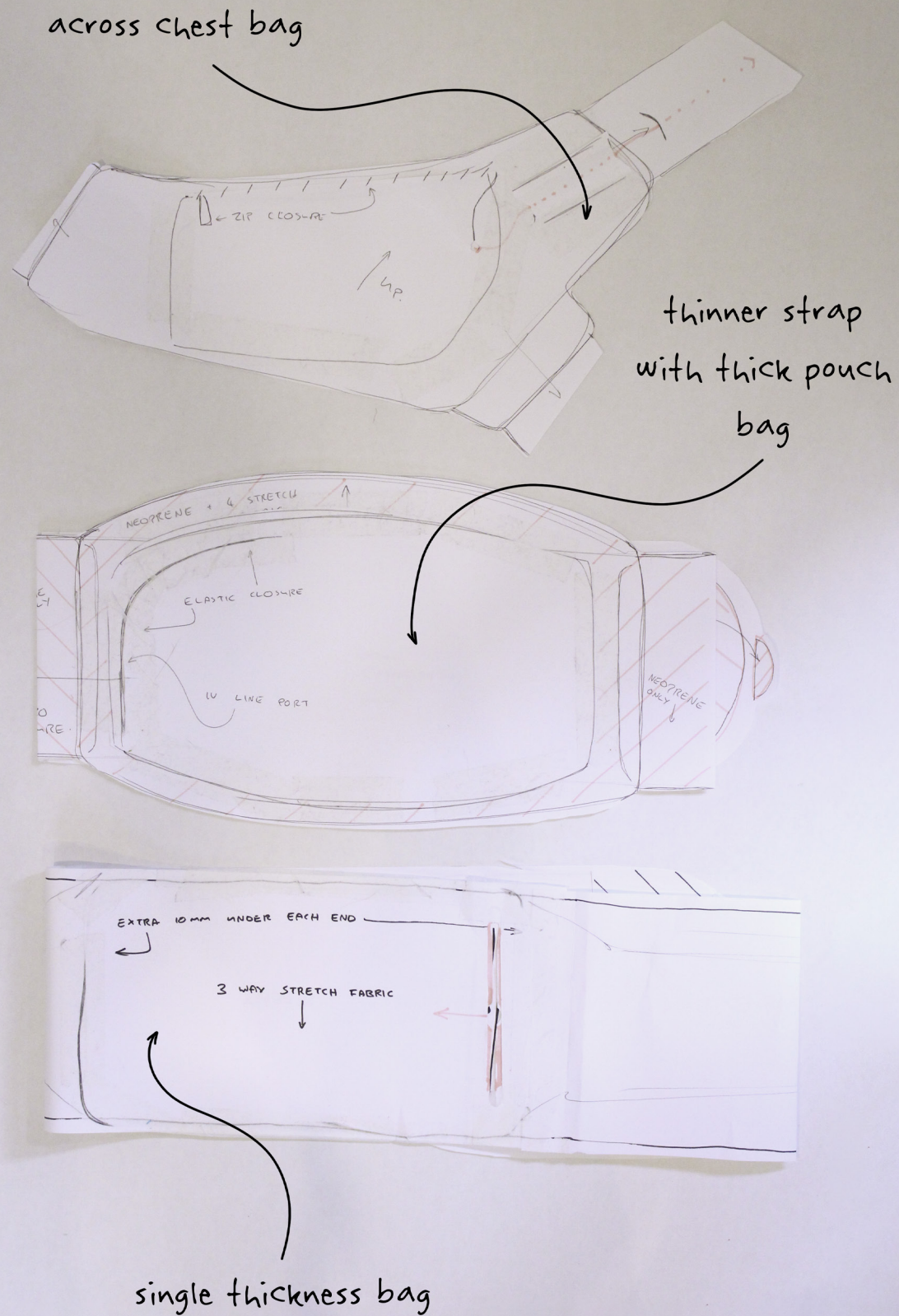


Figure 85. Further refinement and bag exploration based on most successful initial storage bag concepts. The highlighted bags were the most successful.



Aside from colour and bulk, some patient participants experienced issues with the existing Baxter brand bag working its way loose throughout the day and with fit difficulties. I found that a hook and loop ('Velcro') and elastic band system would be better to replace the current clip system through discussions with participants and early prototyping. The Velcro closure allowed for a more seamless join between edges of the belt and required less dexterity to manage.

Figure 86. Low fidelity pattern prototyping for the storage bag. These were explored in three versions: a fixed-width waist bag, variable width waist bag and a crossbody bag. Each featured a different infuser slot position.

Building on the previous concepts and testing, I found that a consistent width bag and strap would create pressure under the user's ribcage. The wider strap also caused excess overheating. To avoid this, I developed the variable thickness bag and the crossbody bag further.

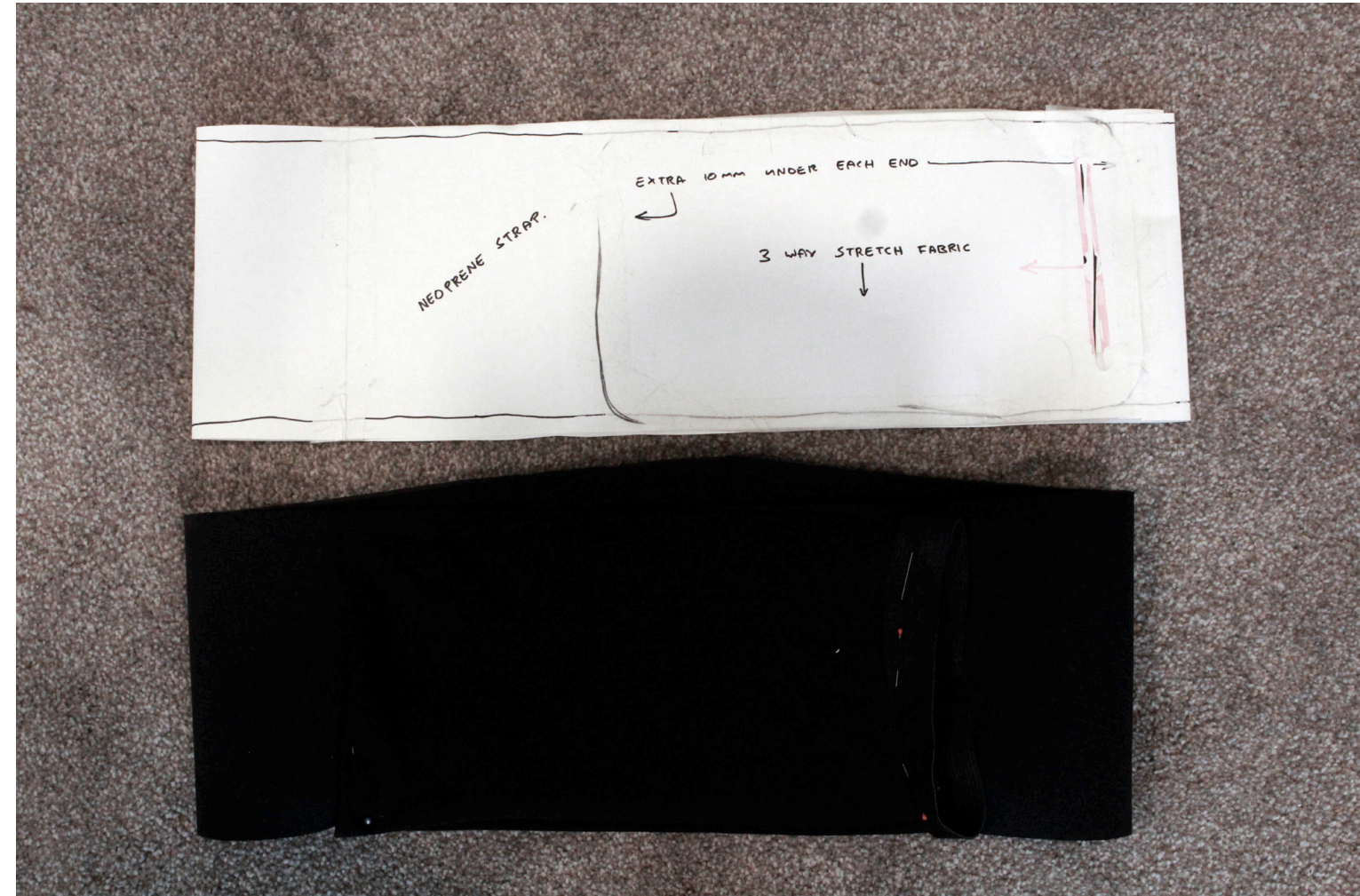


Figure 87. A refined prototype with higher fidelity fabric exploring ergonomics and how the IV storage bag could fit more comfortably on the user's body. Neoprene was used for the strap, along with four-way stretch cotton for the pouch.

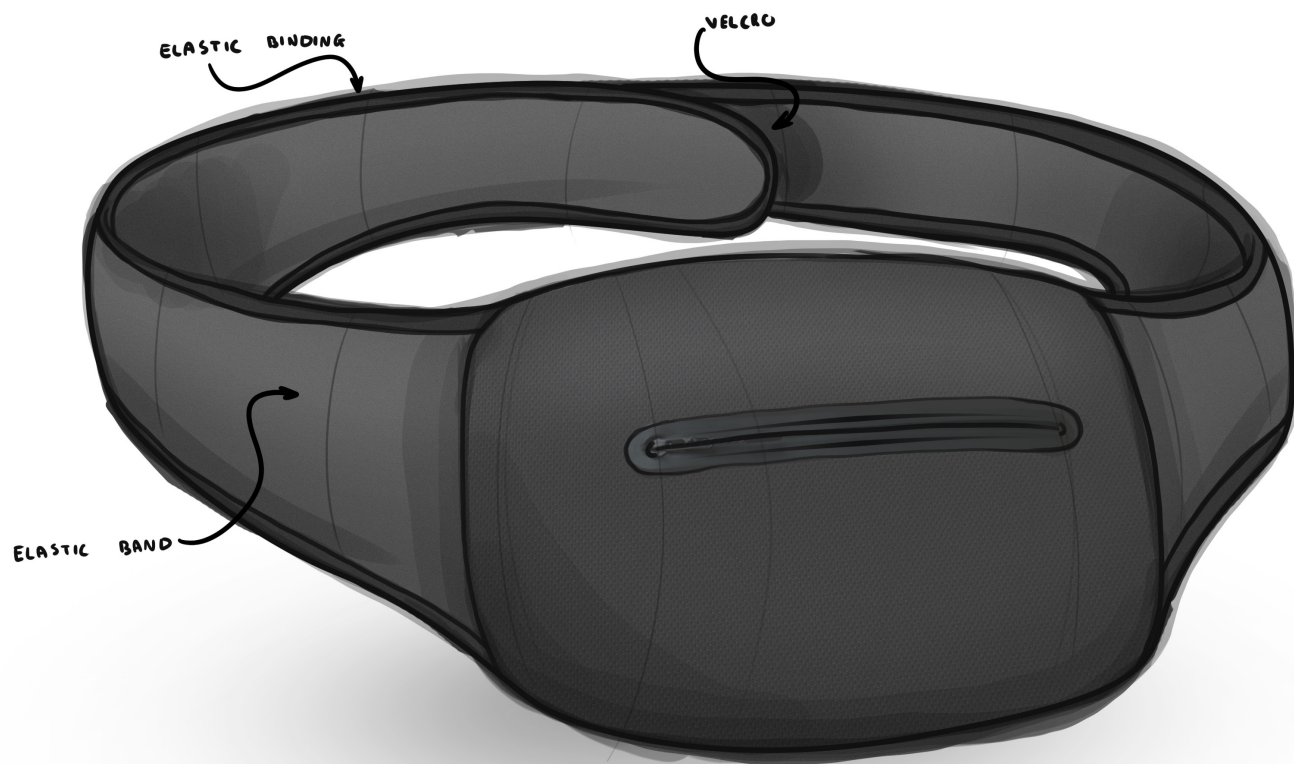


Figure 88. Low profile waist bag concept. Focusing on a simple Velcro closure with a central zip allow for easier IV-line placement and infuser removal.

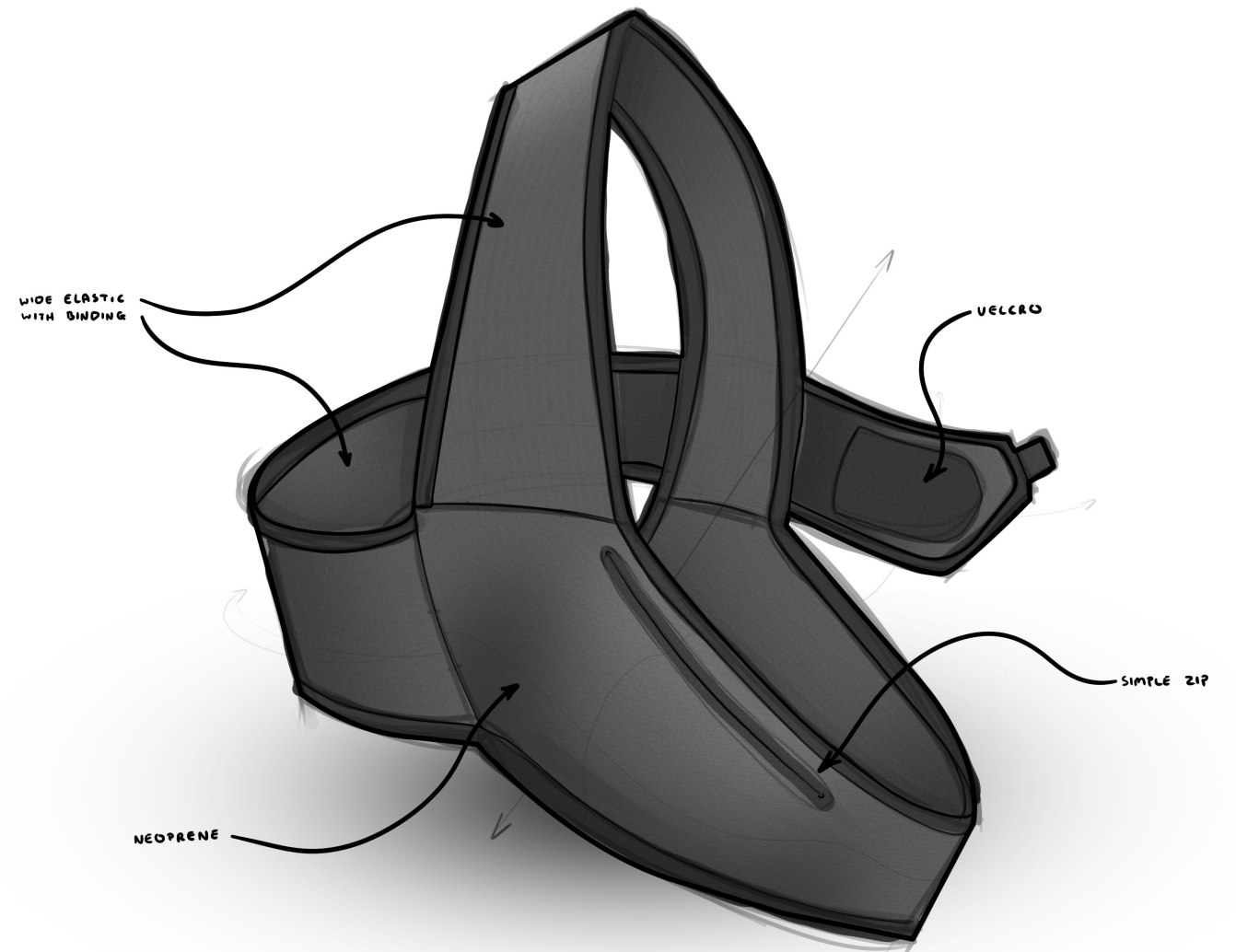


Figure 89. Crossbody bag concept. One benefit of this version was that the bag could use the shoulder strap to route the IV line directly to the user's arm.

Second Expert Critique

Expert User, Previous Patient and OPIVA Nurse

The two IV bag concepts were presented to the participants as paper mock-ups and rendered drawings. The expert user's main concerns were focused on the thermal regulation issues that might arise from wearing a fabric bag close to the skin. They were also concerned that a crossbody bag might be uncomfortable and hot for people with breasts or people in menopause. Although it was still necessary for the patients that the infuser bag could be worn close to the skin, the downside of this was that without breathable fabric, the bag could become hot and uncomfortable to wear. In addition, the infuser needed to be insulated to keep the antibiotics cool, so balancing thermal regulation and insulating the infuser was a concern for the materiality of the system. The participants also noted that the cross-body and waist bags would not be easy to fit with limited mobility as they featured rear closures. The OPIVA nurse also felt the low-profile bag was a positive change for the system, especially the inclusion of a Velcro strap over the current clip used. All participants felt that the bag's closure should be located at the front or slightly to the side to keep the process of fitting the bag as easy as possible. Along with this, I decided to explore only the waist bag further to avoid overheating issues and create a more accessible design.

Ideation Based on the Second Expert Critique

Initially, I had intended to have the 'Velcro' at the back of the belt. However, after the second expert critique, the closure was moved to the side to ensure it was easier to remove by the user. The decision was also made to use spandex coated neoprene as the primary construction material for the bag. This material choice was made due to the superior comfort on the user's skin and the insulating properties of neoprene (Corona et al., 2018; Wakabayashi et al., 2008). In addition, the use of neoprene would mean the user would not develop a 'hot patch' while wearing the bag while simultaneously keeping the infuser cool.

Further research around neoprene production found that using a spandex binding on the neoprene rather than leaving it unbound or using overlocking would be the best for user comfort (Fischer, 2015). Along with this, the bag's construction was kept relatively simple by using the natural padding and stretch of the neoprene to support the user's comfort while keeping the infuser close to the body. In addition, the use of spandex to bind the neoprene would allow the bag to be worn comfortably across the body with the strap resting on the user's neck. The bag was designed to be worn around the waist. However, I wanted the design to be usable in other ways depending on the user's mobility.

Mood board images removed for copyright reasons.

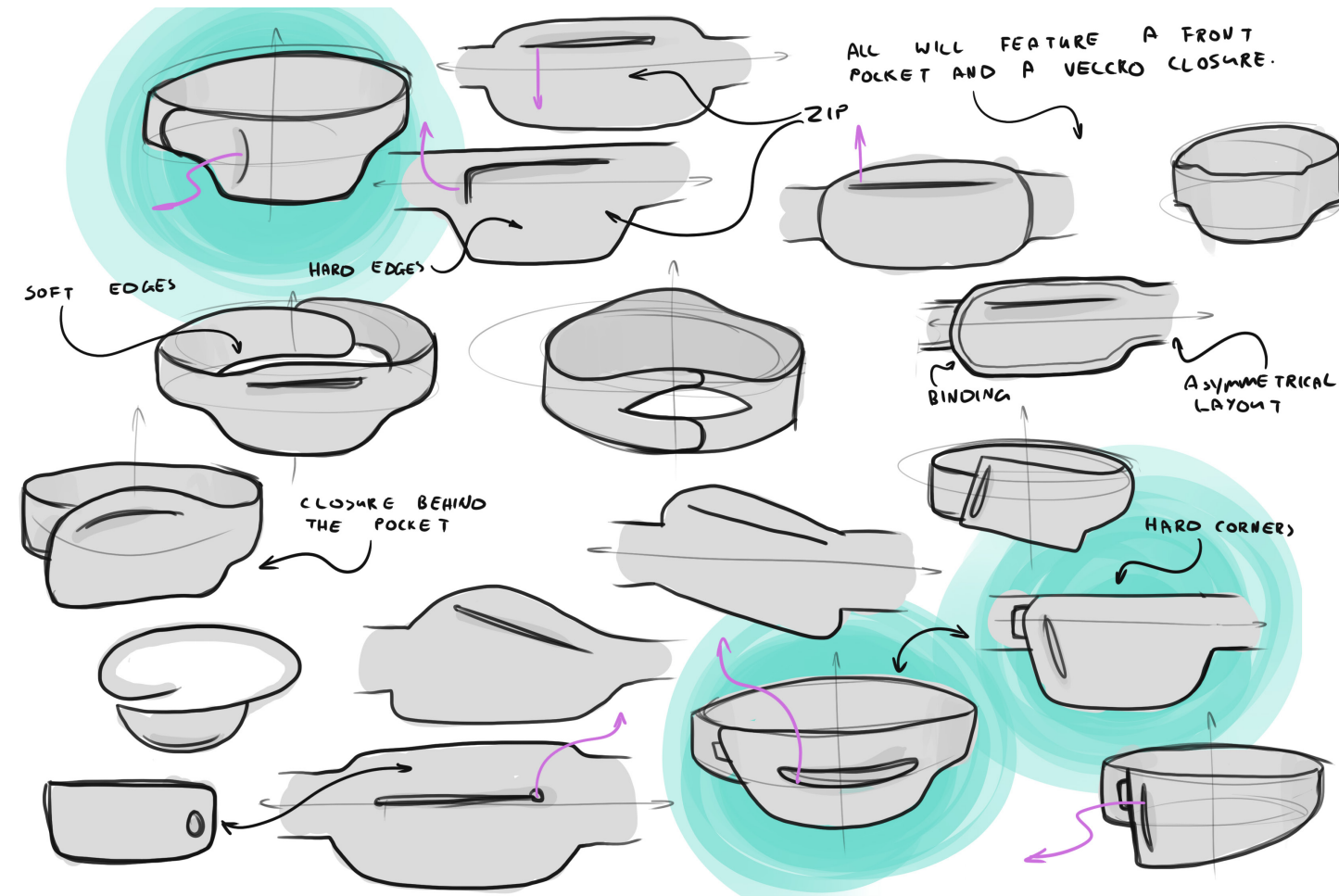


Figure 90. A mood board to explore the aesthetic and materiality of the infuser bag system. The aesthetics behind this part of the system were largely focused on keeping the design minimal and cohesive with the rest of the system.

Figure 91. These initial sketches explored the shape of the bag and pouch function. Depending on the orientation of the pouch opening, different concepts required different closure methods (such as a zip or a hook and loop closure). The designs I chose to explore were selected based on how comfortable they would be for the user (assumptions based on earlier prototypes) and how easy the bag would be to open and close for the user. Although the storage bag was a simple part of the system, aesthetic elements such as coloured tabs to make use clear and easy to understand were essential to the success of this part of the system.



Figure 92. By using an extension to the storage bag strap, the bag could be worn either around the waist, as intended, or around the shoulders as an across chest bag.

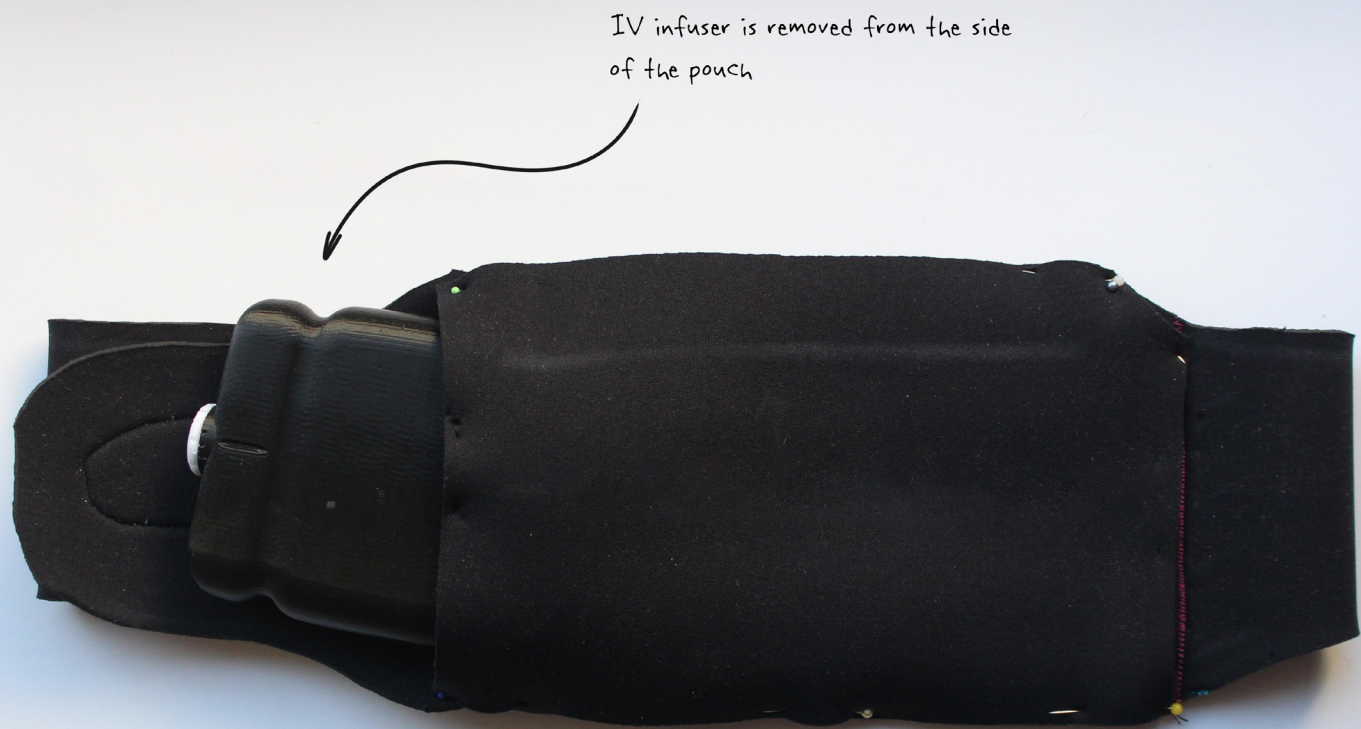


Figure 93. The bag's most successful IV outlet location was the side opening due to its simple insertion process and lower overall bulk in the system.

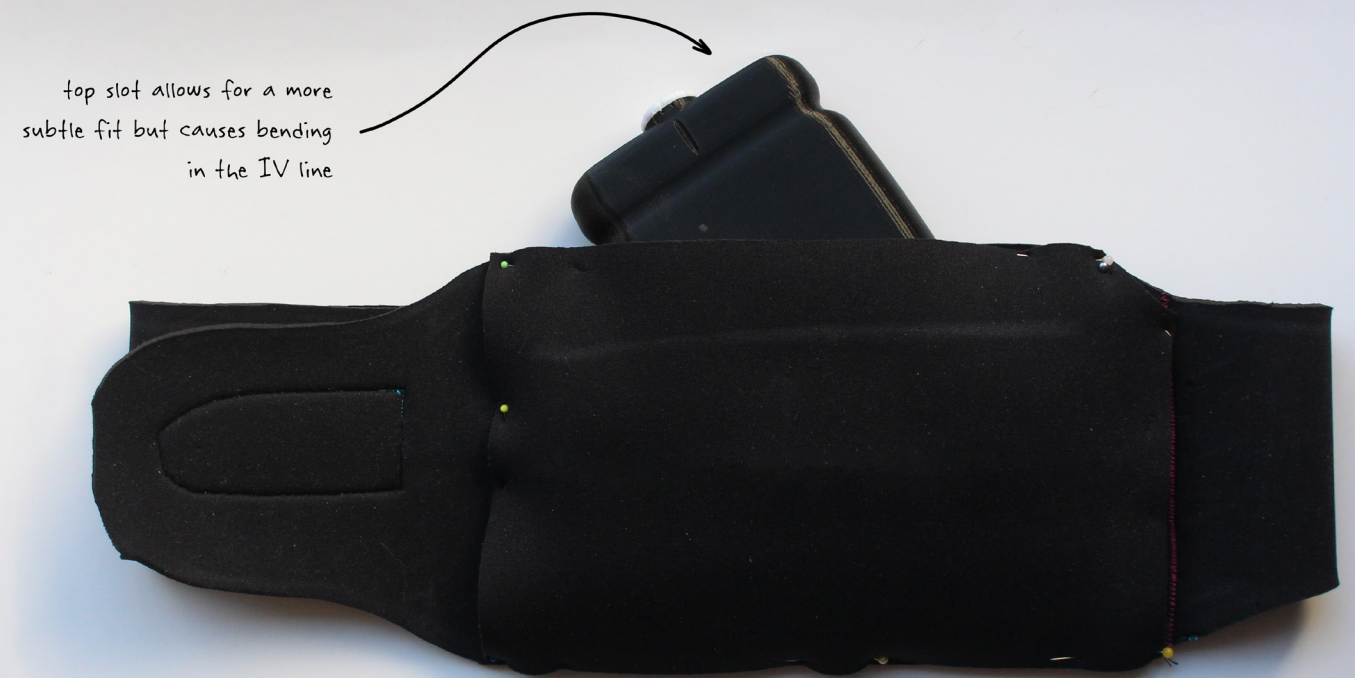


Figure 94. Although the top opening worked similarly to the side, it involved bending the IV line into the bag to fit the infuser and was not as intuitive to use as the side opening.



Figure 95. The front opening, although aesthetically pleasing, was the least functionally appropriate option as the IV line coming out at this angle gave extra thickness to the system, which compromised the low-profile design.

The decision was made through user testing that the bag's opening should be on the side of the bag. This version was carried forward into the following stages of development.

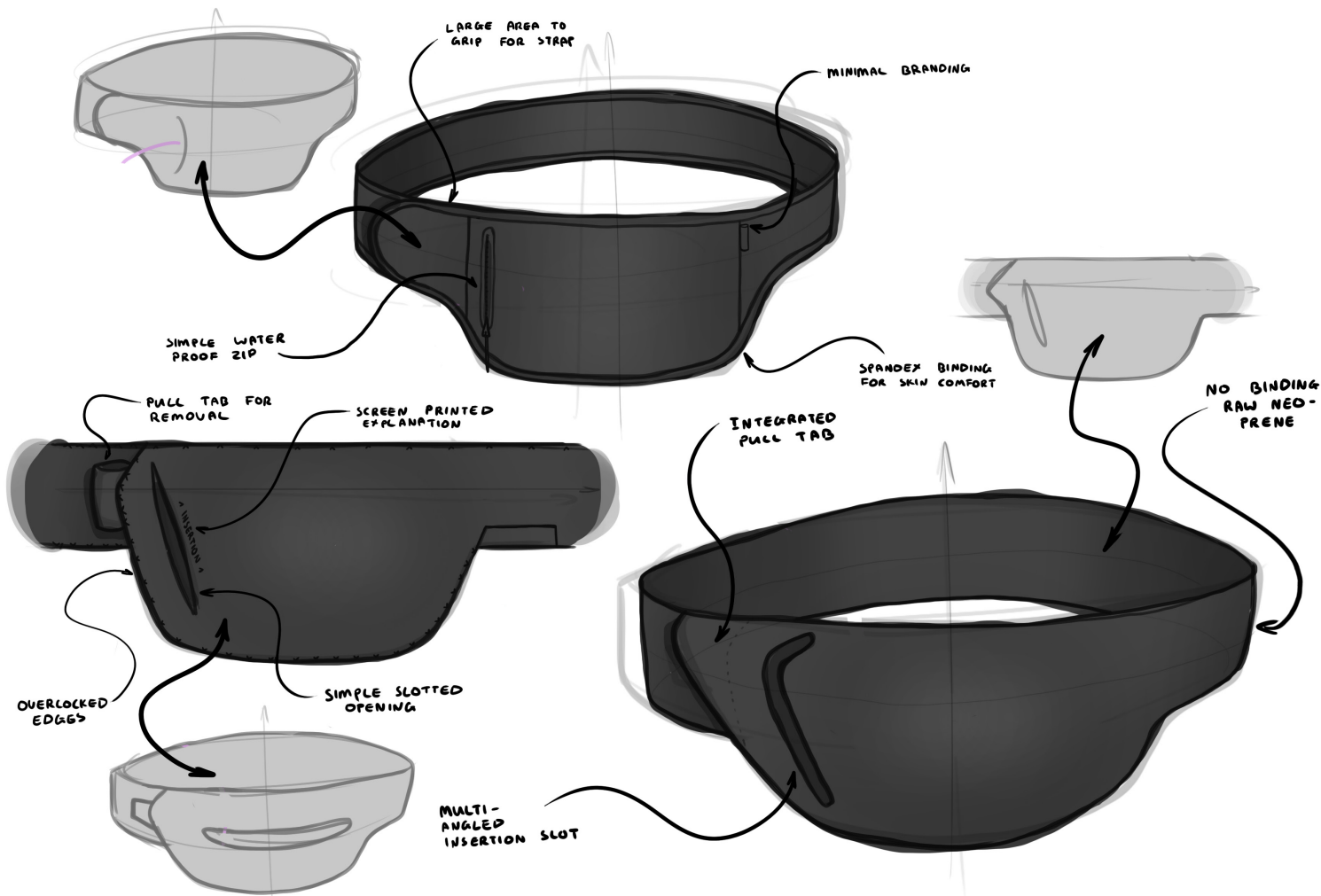


Figure 96. Exploring refined versions of the three most successful bag concepts. The key differences of each design were focused on the position of the strap release point and the infuser pouch opening. The top concept featured a zip, while the other two used a simple slotted opening.

fit against body	7	6	6
asy infuser changes	8	9	8
low profile	6	6	6
fit on different bodies	7	7	6
infuser line position	9	7	8
	37	35	34

Figure 97. Infuser bag concepts evaluation matrix. Concepts one through three (left to right) were rated based on the same criteria as the infuser. The choice to use these criteria assumed that the user mainly interacts with the infuser (during day-to-day activities) when used with the storage bag. Based on these criteria, the first concept was considered most successful.

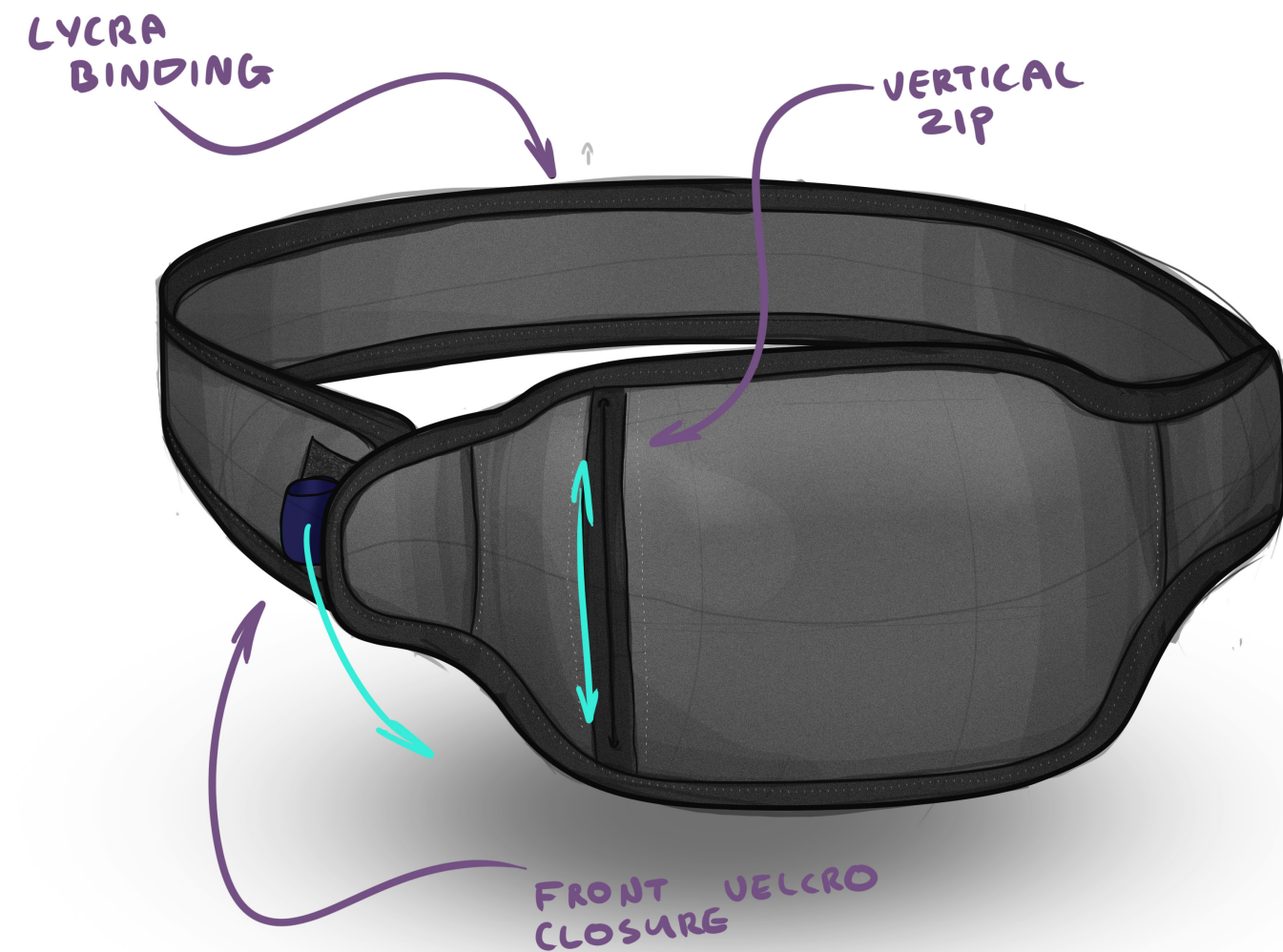


Figure 98. Based on paper prototyping and pattern making, and the evaluation matrix, the bag was adjusted towards a final concept. Because the bag would be worn under the users clothing, I wanted to keep colours and branding to a minimum. Some participants liked the existing blue waist bag provided by the OPIVA service, while others disliked it. To avoid such disagreement, I decided to follow a more minimal aesthetic to be less polarizing.

Third Expert Critique

Expert User

A rough prototype of the final bag concept, along with the rendered drawing, was presented in the final expert user critique. The expert user participant liked the inclusion of the side closing strap on the bag as they felt it would be more comfortable and easier to use. Along with this, they felt that the decision to have a waist bag design would be positive to avoid overheating as well as minimal inconveniences during day-to-day use. In terms of aesthetics, the participant was pleased with the more minimal aesthetic choices as they had expressed discontent with the original bright blue colour of the bag provided by the OPIVA service. They felt that the black colouring and option to use the bag under their clothing were preferable over the existing offering.



Figure 99. The early neoprene waist bag prototype presented during the third expert critique.

Infuser Storage – Finalising

Following feedback from a neoprene production company, I decided to move away from using a zip in the storage bag as neoprene could hold its shape better than other elastic materials. In addition, the zip would likely force the IV line to bend, which could reduce the flow of antibiotics. Along with this, the final design was ‘tweaked’ slightly with branding additions to fit with the brand identity of Baxter. Although Baxter’s brand colour was navy blue, some of the research participants did not like this shade of blue. Therefore, a small pull tab in Baxter’s signature blue was added along with their logo to match Baxter’s brand and ensure the system was neutral in aesthetic. The pattern was tested using paper and then produced using spandex coated neoprene.

The final infuser storage bag was produced using 2mm and 3mm neoprene. These thicknesses were chosen as the 3mm neoprene used for the bag strap added some padding but was not overly heavy or thick to avoid overheating or excess weight. The 2mm neoprene used in the pouch ensured that the infuser was held securely in place and would smooth out the shape of the infuser further for a better fit under clothing. Although neoprene was more expensive than the nylon used in the existing bag, I felt that the benefits that neoprene would provide in low profile fit and user comfort outweighed the increased cost.

The Infuser Storage System - Further Refinement

Initially, I started exploring the IV clip system in conjunction with the sterile dressing and the PICC line stabiliser. I considered three areas in the design of the IV clip system; the mechanism that locks the IV line in place; the shape of the clip itself; and extras such as support for the IV line and non-slip coatings. The IV clips needed to have a well-considered aesthetic that matched the rest of the system. The parts also needed to be low-cost and easy to produce.

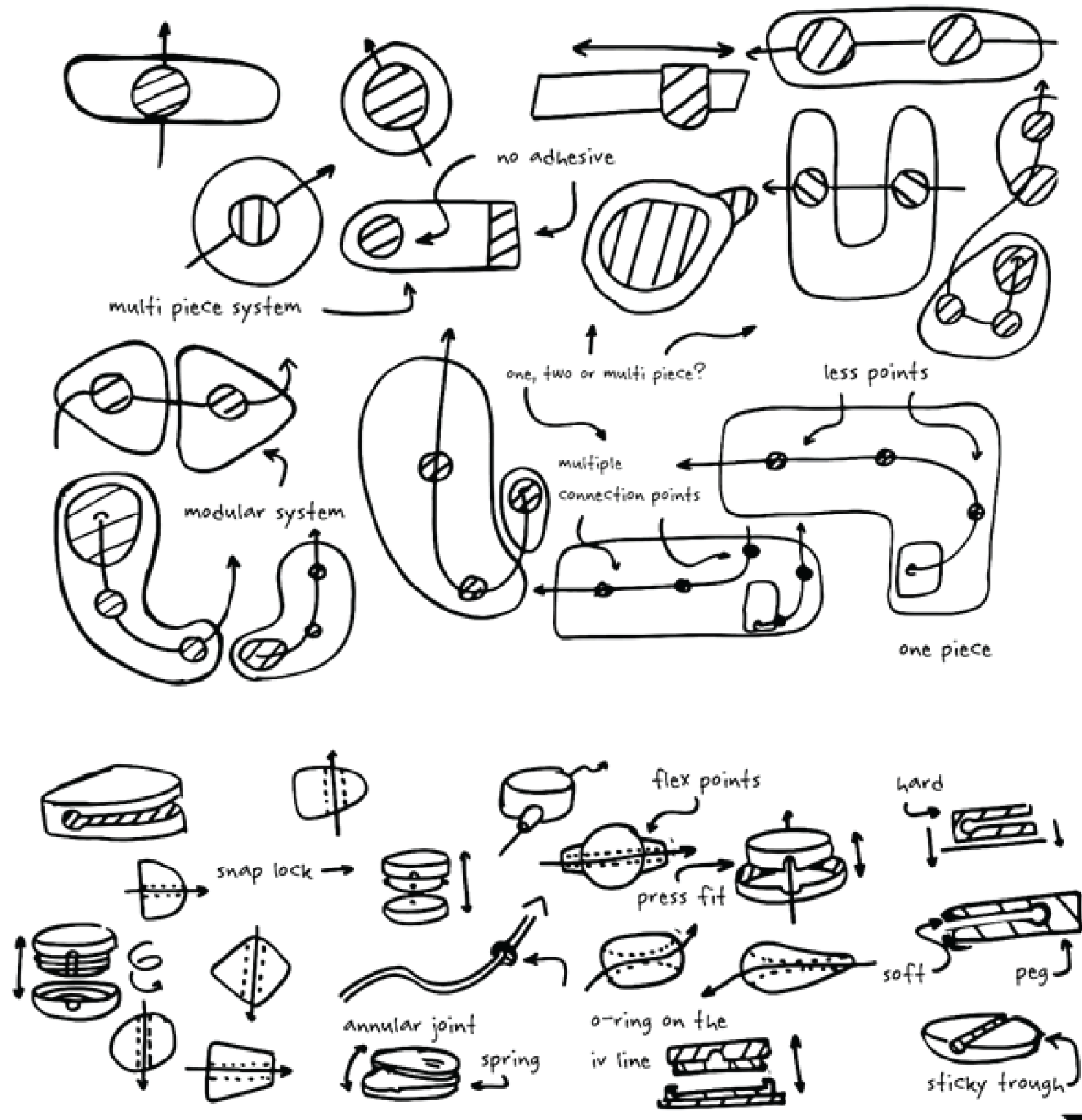


Figure 100. Dressing form and IV connection mechanism ideation and refinement.

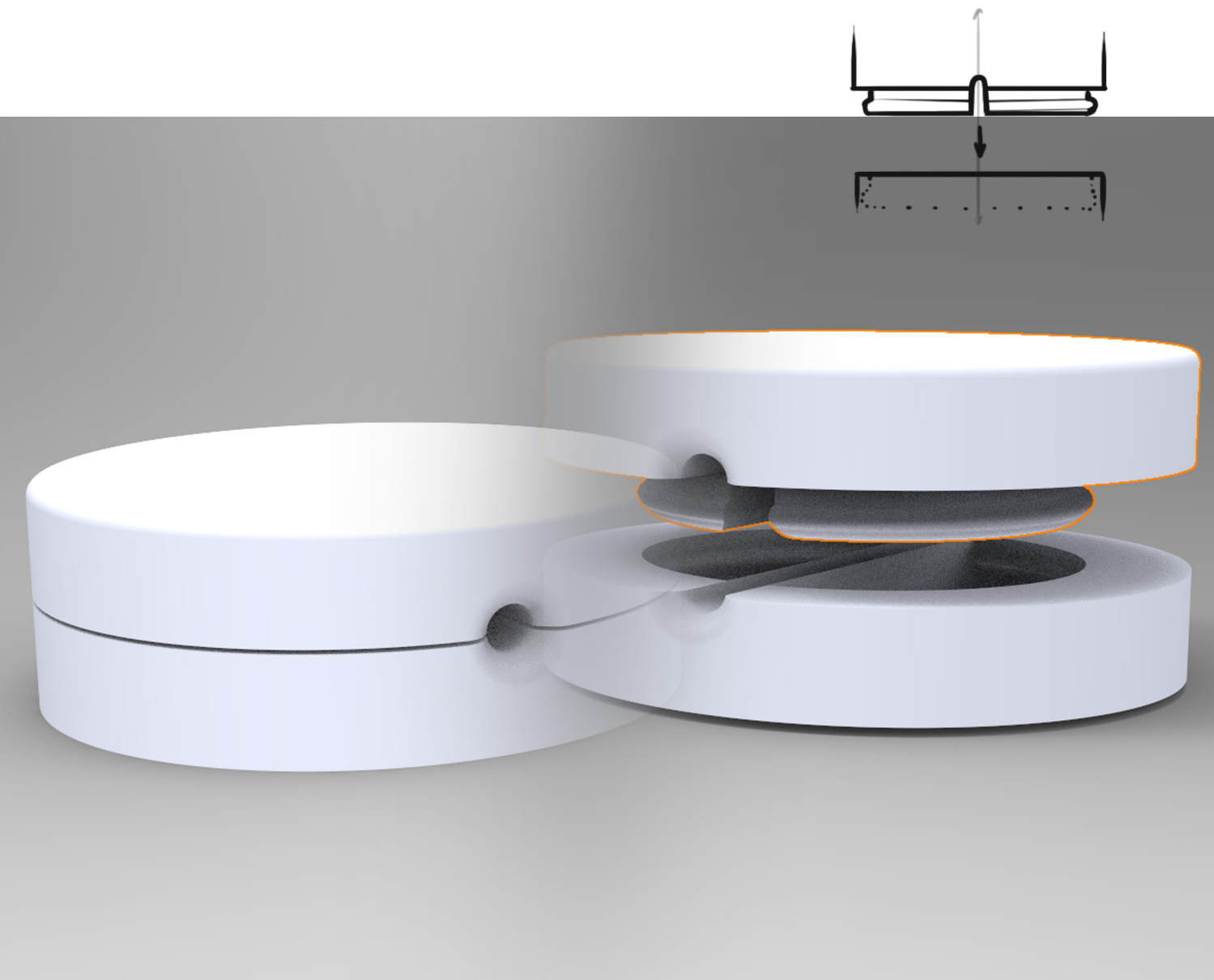


Figure 101. The first IV clip joint system used a press-fit annular joint with a slot for the IV line.

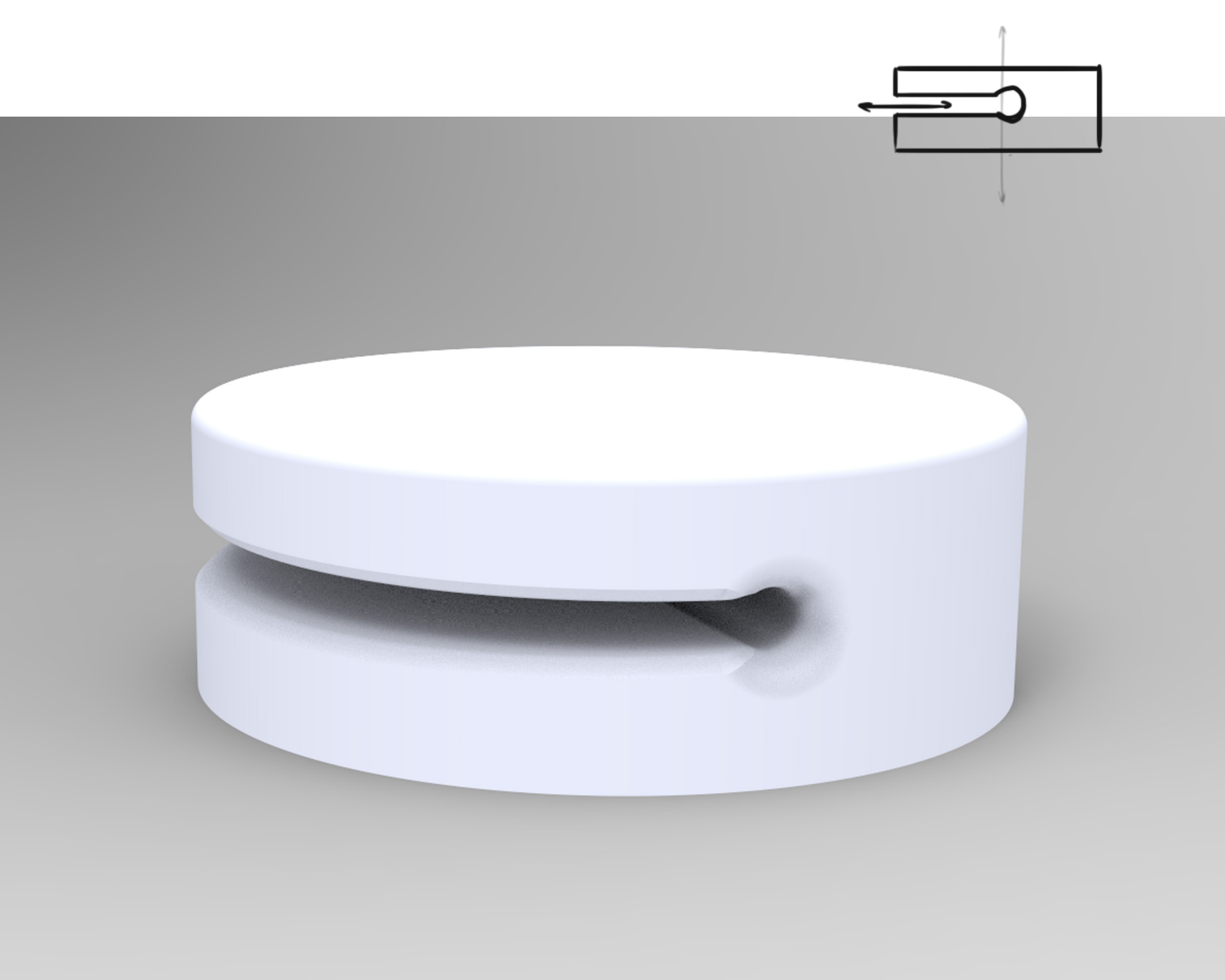


Figure 102. The second concept used a slide fit IV locking system. This concept used the natural flexibility of the IV line to hold it in place.

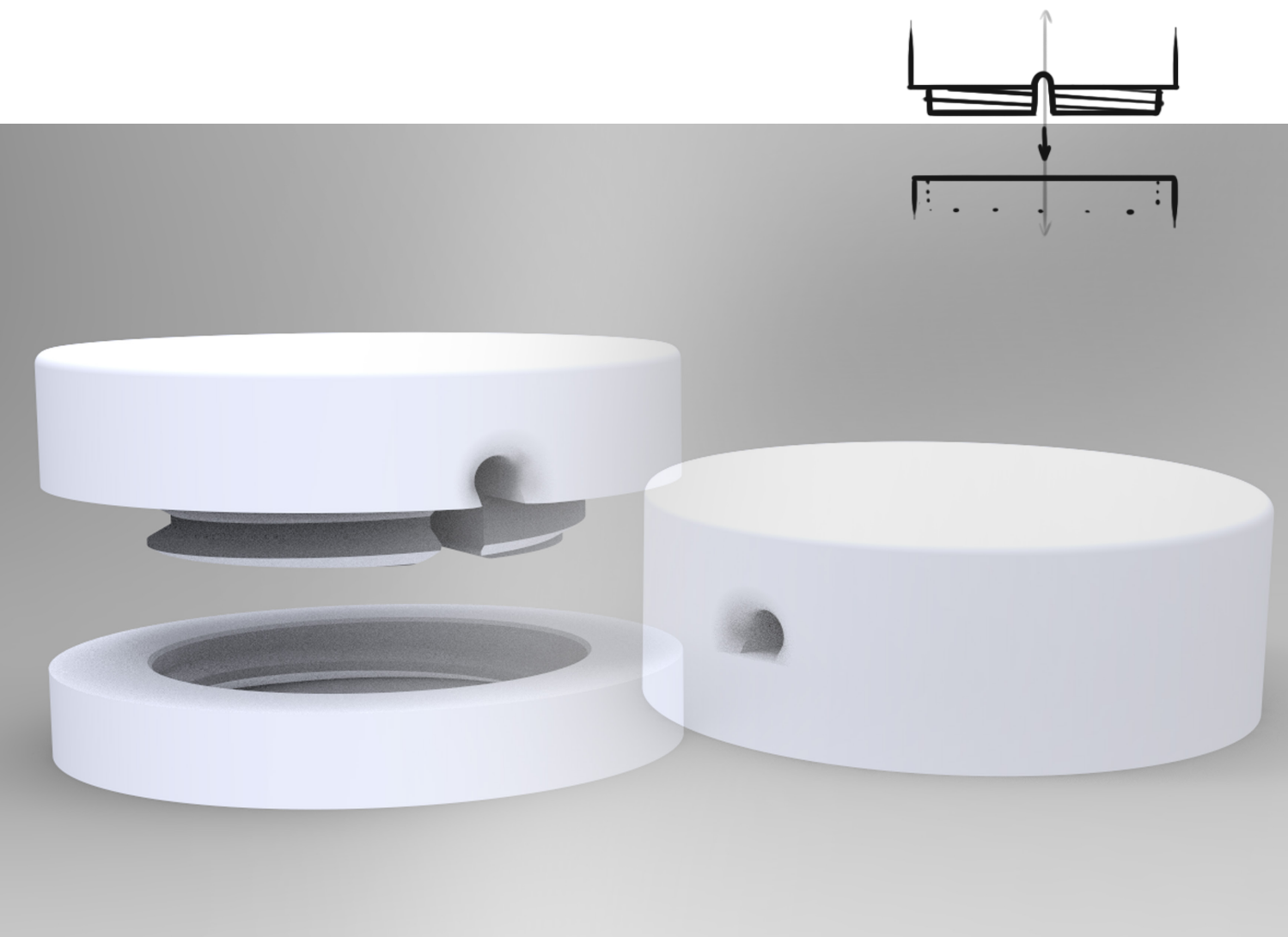


Figure 103. The third concept had a threaded locking system. The threaded parts held the IV line effectively but were difficult to tighten with one hand when placed on the upper arm.

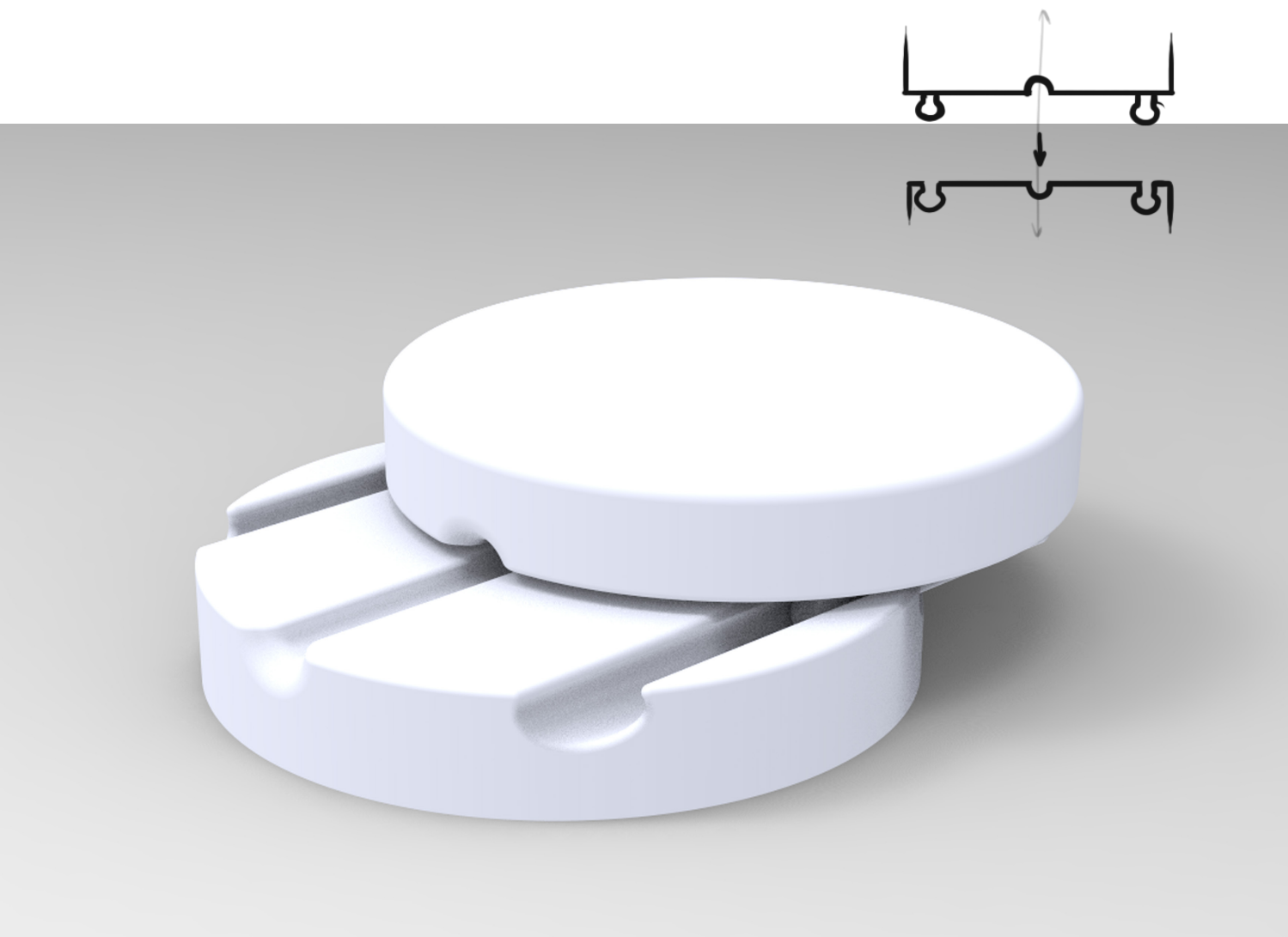


Figure 104. The fourth design was a slide locking IV clip system. The design was not very viable as the IV line and slide directions were the same resulting in a system that did not work well.

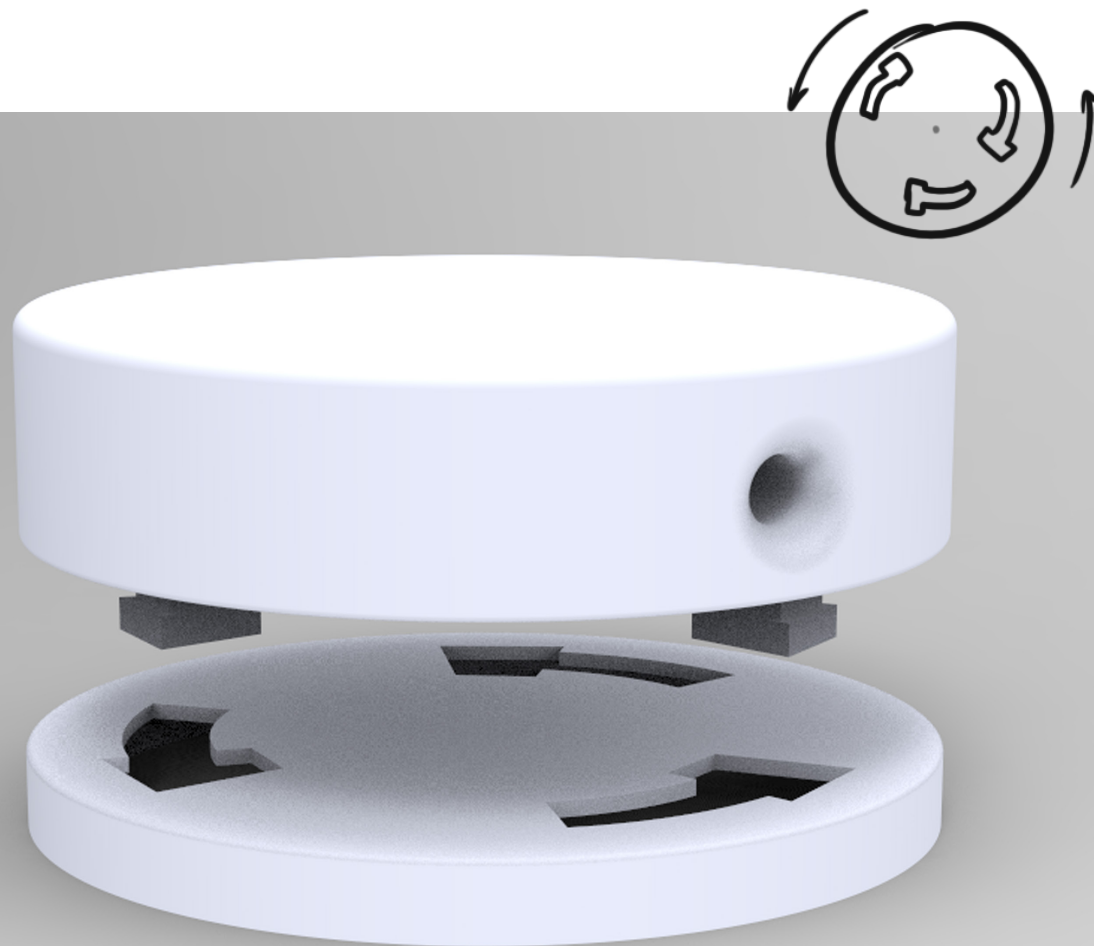


Figure 105. The fifth prototype used a gutter lock to twist-lock the two halves of the clip in place. This system functioned quite well but was still slightly difficult to manage with only one hand.

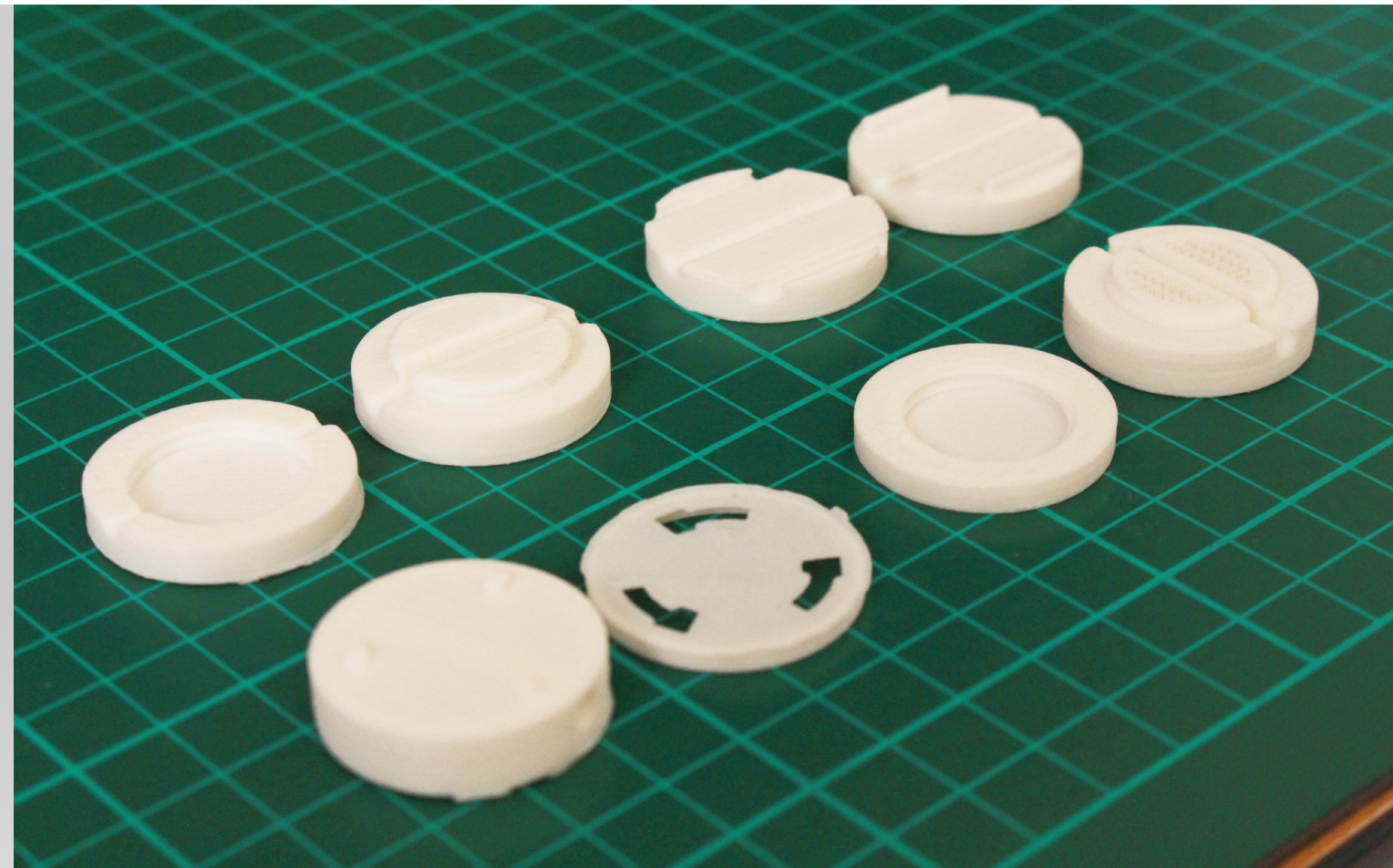


Figure 106. Each IV clip concept was 3D printed to test tolerances the function of the joint. The slide fit concept was not included in these tests as no parts had to join together.

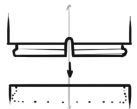
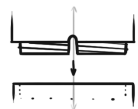
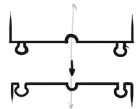

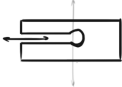
					
intuitive function	8/10	7	5	6	7
secure fit	10	9	2	7	6
ease of use	2	3	6	6	9
IV line flexibility	9	7	4	3	6
comfort on skin	2	4	9	8	9
production cost	8	5	8	6	7
	39	35	34	36	44

Figure 107. IV Clip Evaluation Matrix. Each prototype was compared based on the design requirements defined for the IV clip system in the refined design brief. The two highest scored designs were further developed in subsequent stages of the research.

Most of my initial clip concepts used a two-piece clip system. Often these clips would require the user to apply pressure directly to the skin to join the two parts. This pressure could cause discomfort for the user. As a result, two separate IV clip systems were developed: a simple one-piece system that used the natural flexibility of the IV line to hold it in place and an annular fitting press-fit system.

Based on the evaluation matrix, the annular joint press fit and the sliding fit system were the most successful. My initial sketches and CAD models focused on exploring the function of the clip and dressing without directly considering form or aesthetics. For the next stage in the development process, I wanted to explore the function and form of these clips more holistically.

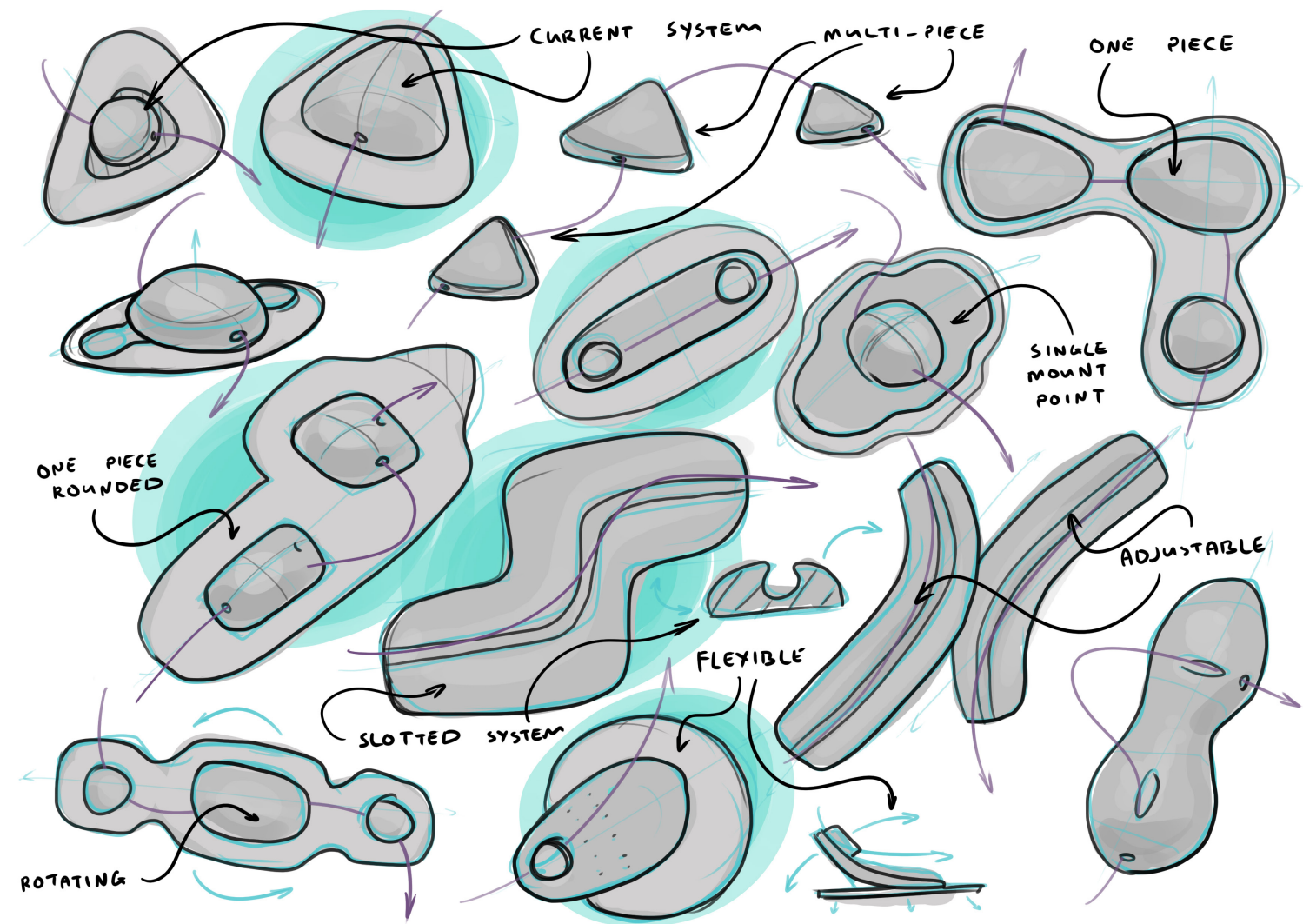


Figure 108. Sketches to explore and refine the dressing and IV clip system. These concepts do not include the PICC line dressing.

	SLOTTED	FLEXIBLE	SLIDE FIT	ONE PIECE DRESSING	THREADED INLINE
secure fit	7	6	7	6	9
comfort on skin	8	9	9	8	7
use with one hand	6	7	8	6	5
compatibility with IV	9	6	5	8	7
aesthetic desire	8	4	3	7	6
ergonomic shape	7	6	6	7	5
	45	38	38	42	39

Figure 109. IV clip and dressing evaluation matrix based on IV clip sketches. The highest-rated options were developed further. The options were rated against the design requirements defined in the refined design brief.

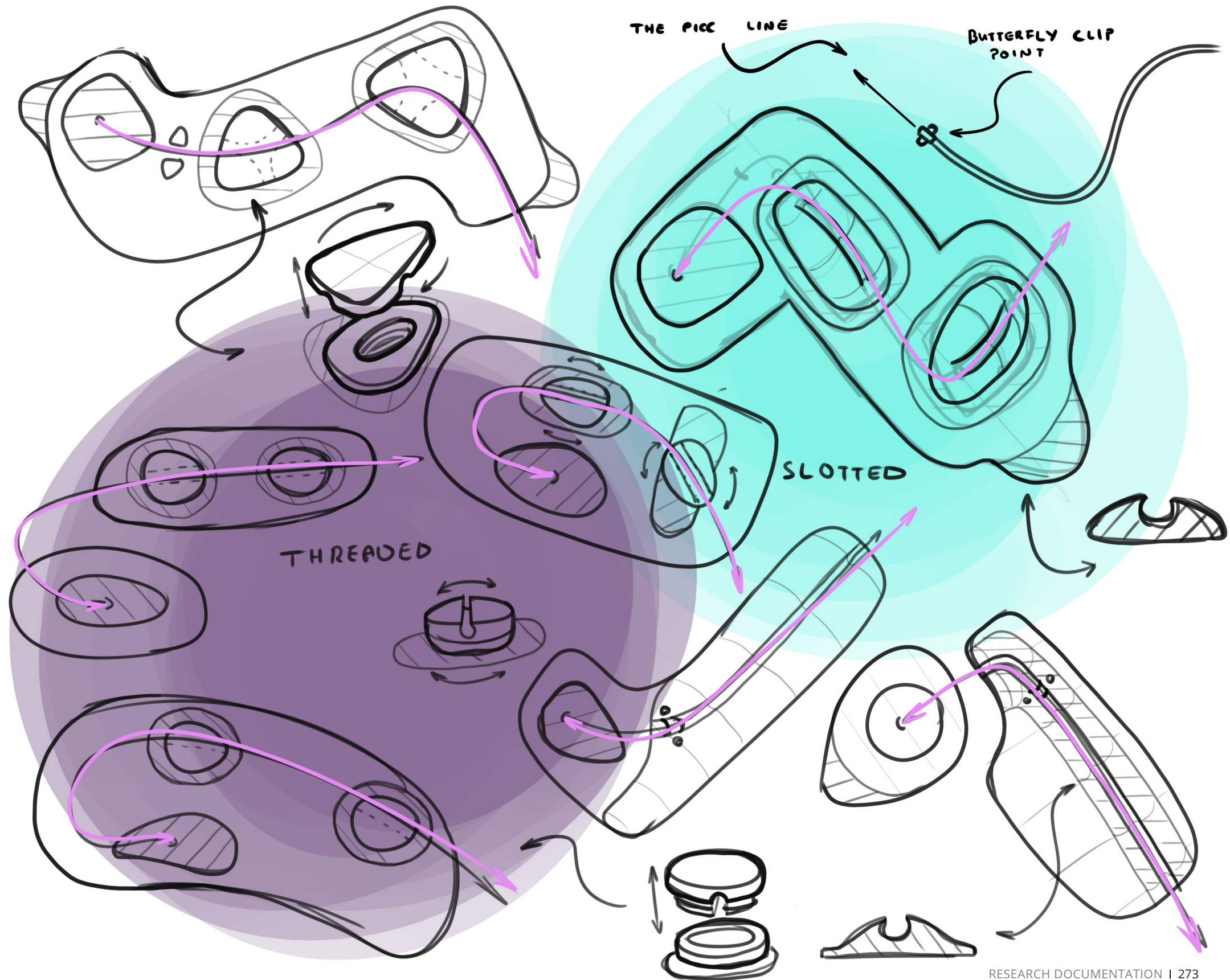


Figure 110. Further sketch exploration of the IV clips and a dressing for the PICC line. Based on the evaluation matrix, the three most successful IV clips were combined with PICC line sterile dressings and PICC line stabilization clips that focused on ease of use for the nurses. Following these concepts, the next stage in the development process was prototyping to ensure that each idea had the same IV-line security as surgical tape.

Dressing and Adhesive Exploration

The existing sterile PICC line dressing (a woven dressing with a clear vinyl window and antiseptic patch) was changed weekly in the OPIVA service. The adhesive could cause skin damage if worn too long, and the anti-septic patch needed to be replaced to avoid damage to the PICC line insertion point (Smith et al., 2016). In this research, the IV-line clip system aimed to improve the patient's experience by removing the need for tape. However, the PICC line dressing was not managed by patients and therefore, any changes to the dressing needed to reflect the needs of the OPIVA nurses.

When wound dressings or skin adhesives used in medicine are designed, often the focus is on microbial management and ensuring low skin irritation (Ghomi et al., 2019; Boateng et al., 2008). Ghomi et al. (2019) define the suitability of wound dressings based on their ability to: maintain wound moisture, support skin healing, ensure breathability, avoidance of overheating, bacteria protection, and allow easy removal following use to avoid further skin damage. The PICC line dressing was the only part of the system that needed to adhere to these specifications as only the PICC line insertion point was an open wound.

I decided to focus on making the adhesive dressings used to hold the IV-line clips in place easy to remove while remaining secure throughout a week of use.

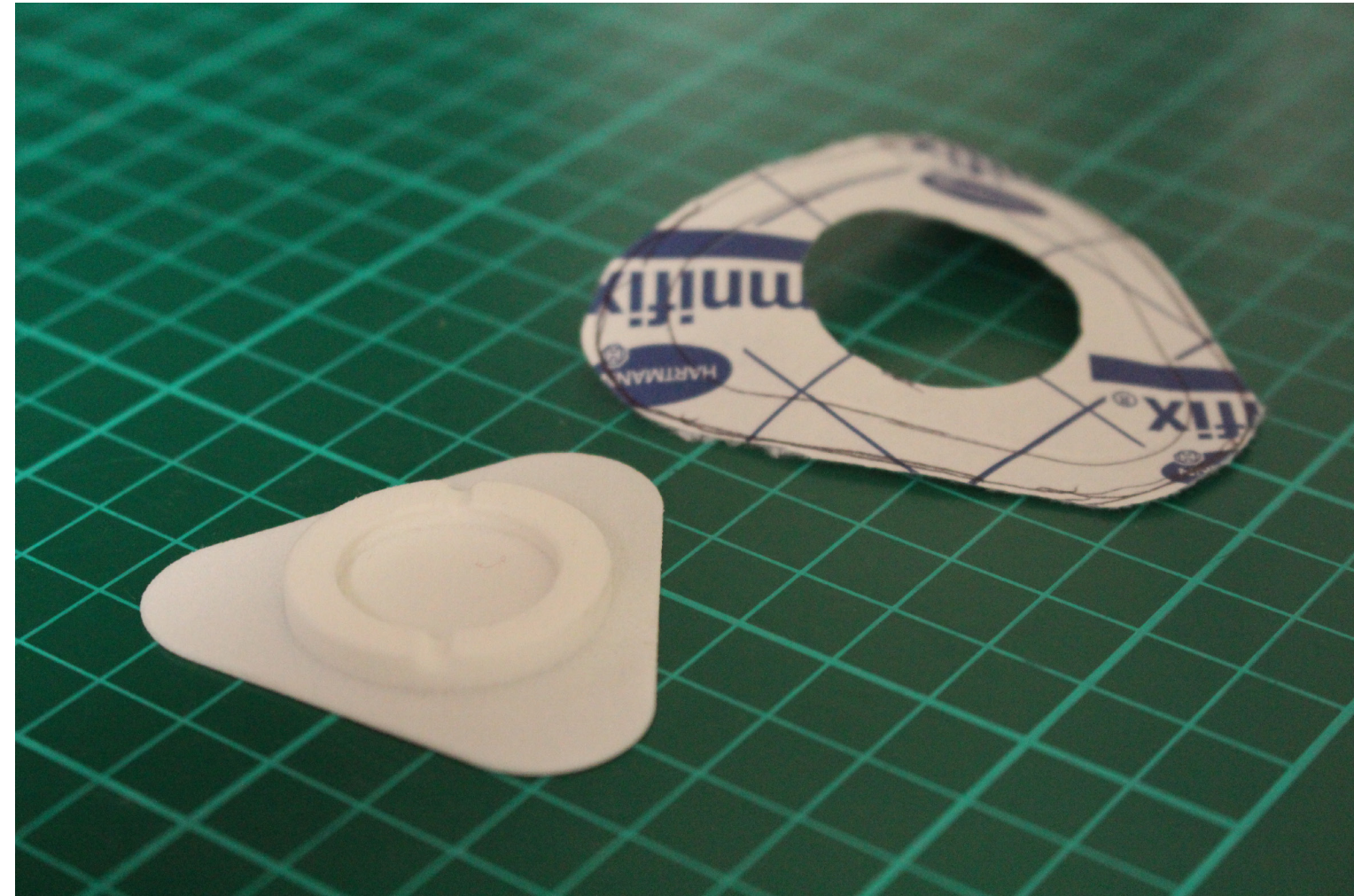


Figure 111. Dressing prototyping with a woven dressing.

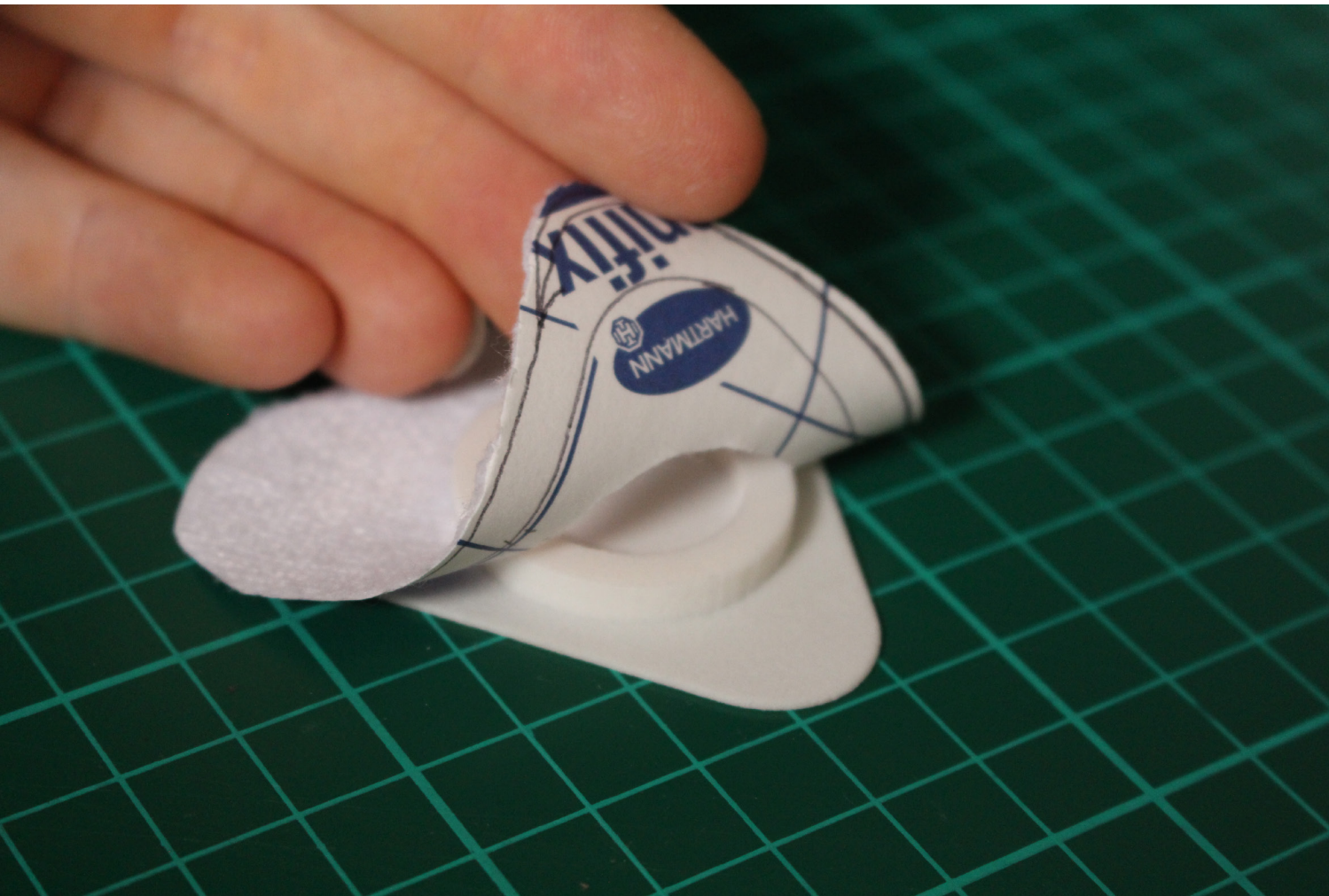


Figure 112. In my initial prototyping of the IV clip dressings, I explored how the IV clip could be a reusable element fitted with a replaceable adhesive dressing. The dressing would have two removable backings, which could be applied directly to the IV clip and then mounted on the patient's skin. Using a woven dressing worked well but would deteriorate when wet.

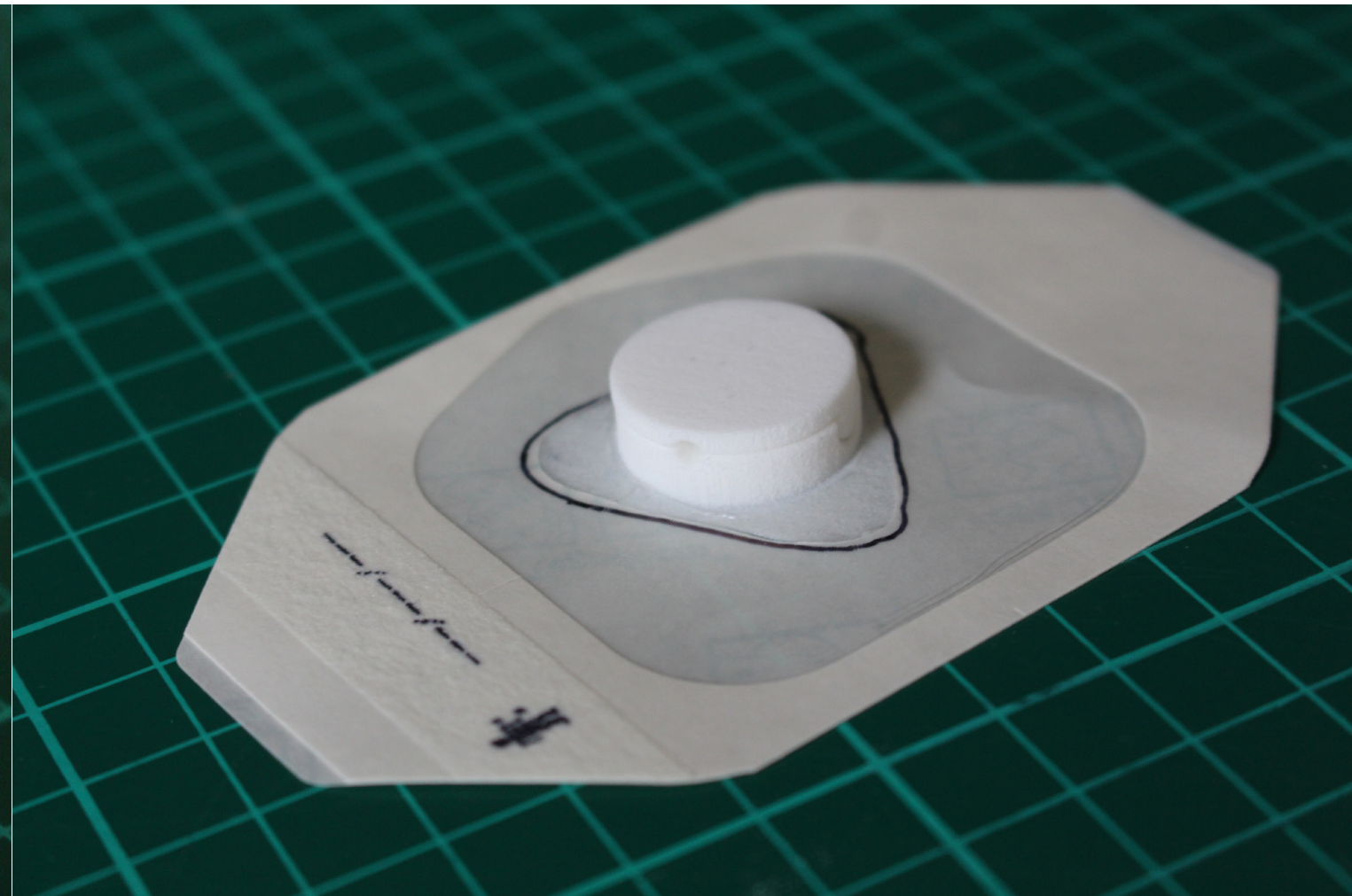
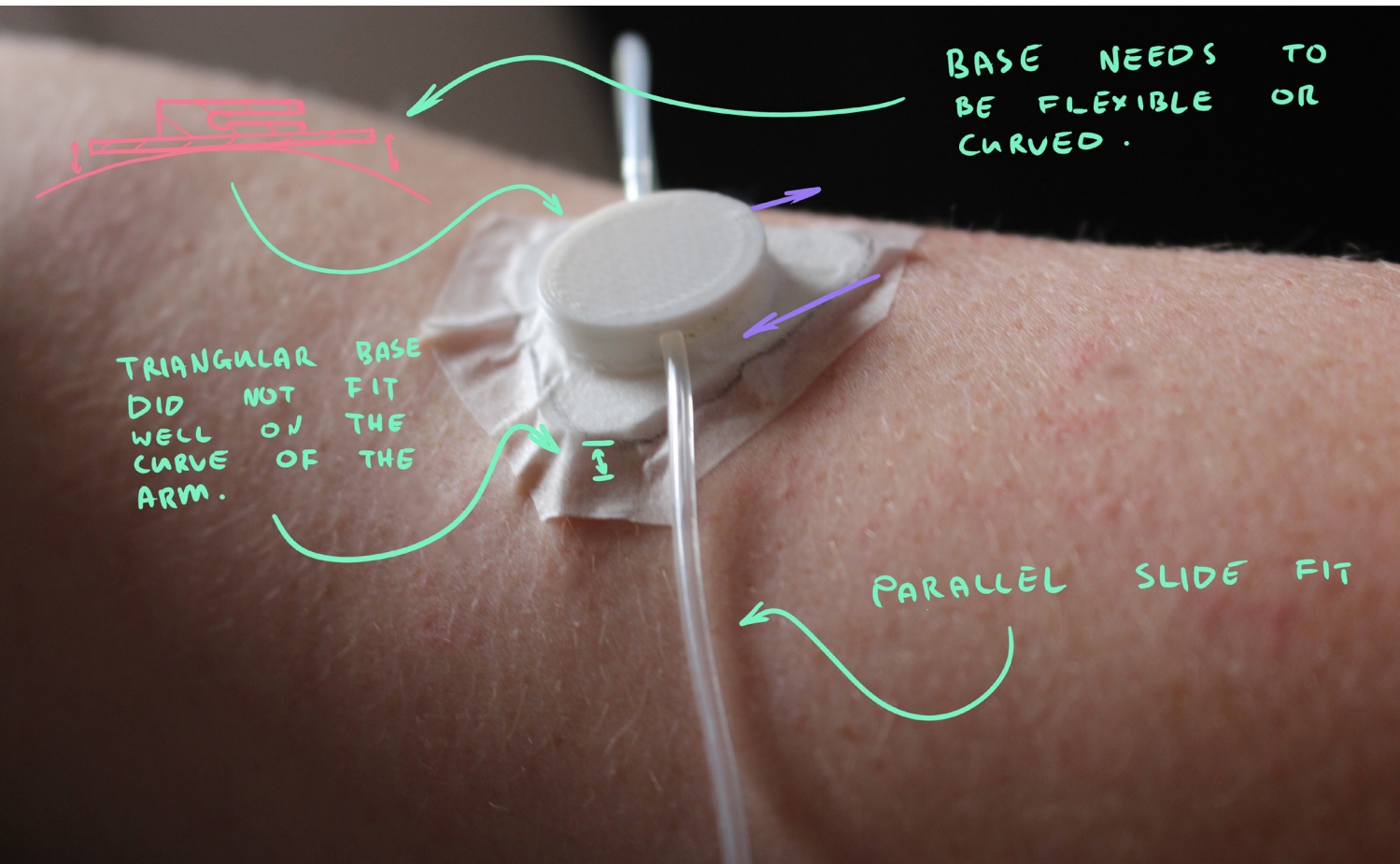


Figure 113. An existing 3M Tegaderm dressing was combined with the IV clip to explore how different dressing materials could be used. Unlike the woven dressing, the vinyl was waterproof but was not rigid enough to hold the clip in place.



Based on my initial exploration, I decided to create two concepts that would be used as research probes in the second phase of expert critique sessions. Each of these concepts featured a slot for the IV line rather than a joint closure. I decided to use the slide fit system as the annular fitting required a part of the IV clip to be removed every day during infuser changes. I wanted to avoid this as any parts that could be lost during use would make the system unusable.

Figure 114. After exploring the mechanism of the IV-clip system, I started to explore and test the clip as part of the entire system. I wanted to ensure that the system would work as intended during use. This prototype used the slotted clip system to hold the IV-line and a paper-based adhesive dressing. I found that the triangular shape I had been exploring did not fit well on the arm leading to gaps under at least one edge of the flat base. The next stage of the IV clip development process was to refine and build on these low-fidelity prototypes.

Multi-Piece Concept

The first concept explored used multiple IV clips placed on the arm to replace the tape. Using multiple clips, I was able to allow the patient and nurse to control the exact position of the clips depending on the patient. This would allow the clips to fit a wider range of patients. In contrast, a one-piece system could be too big for some smaller patients' arms.

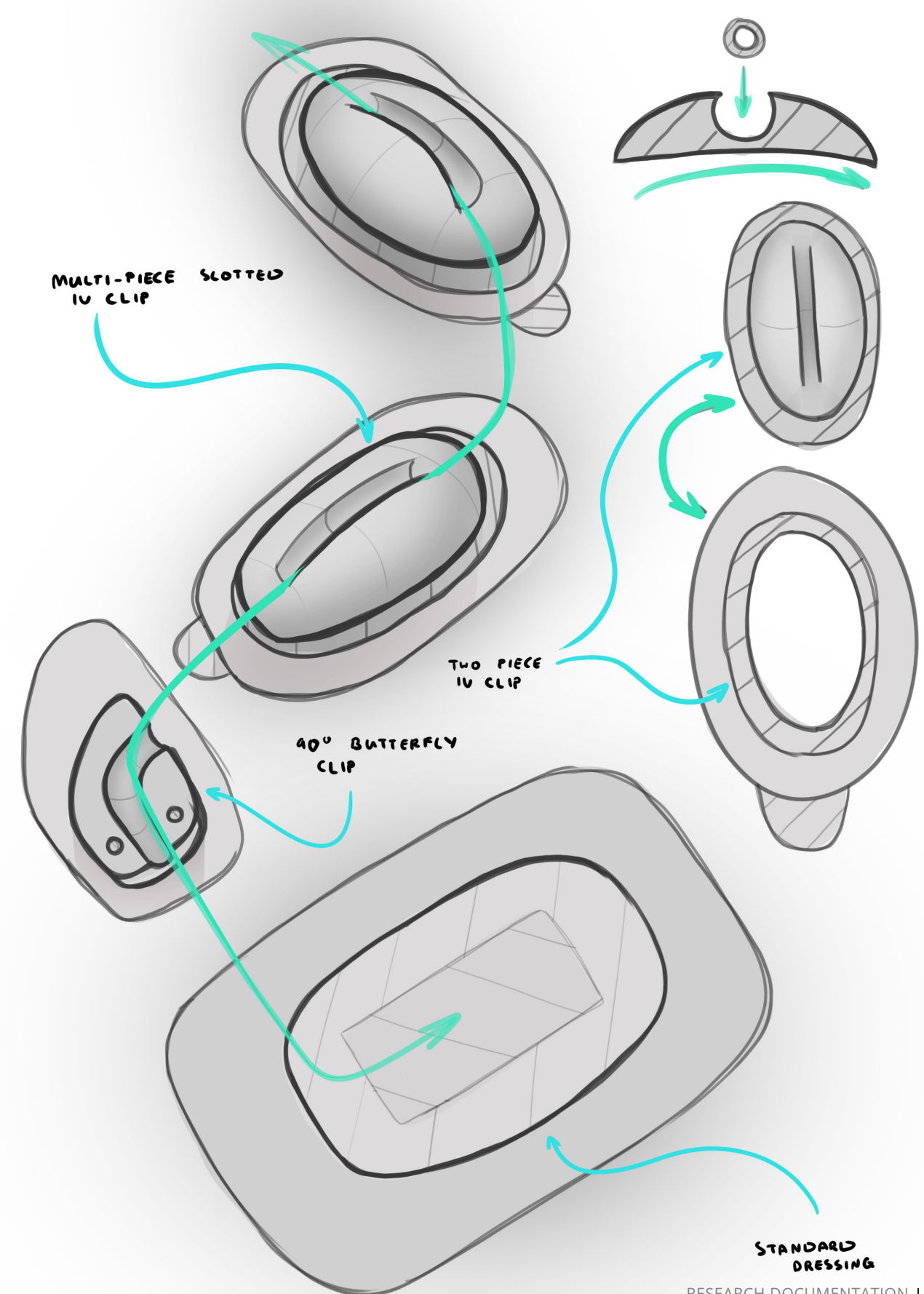


Figure 115. The first refined IV-clip concept. This concept maintained the existing elements of the PICC line system and added two slotted IV clips.

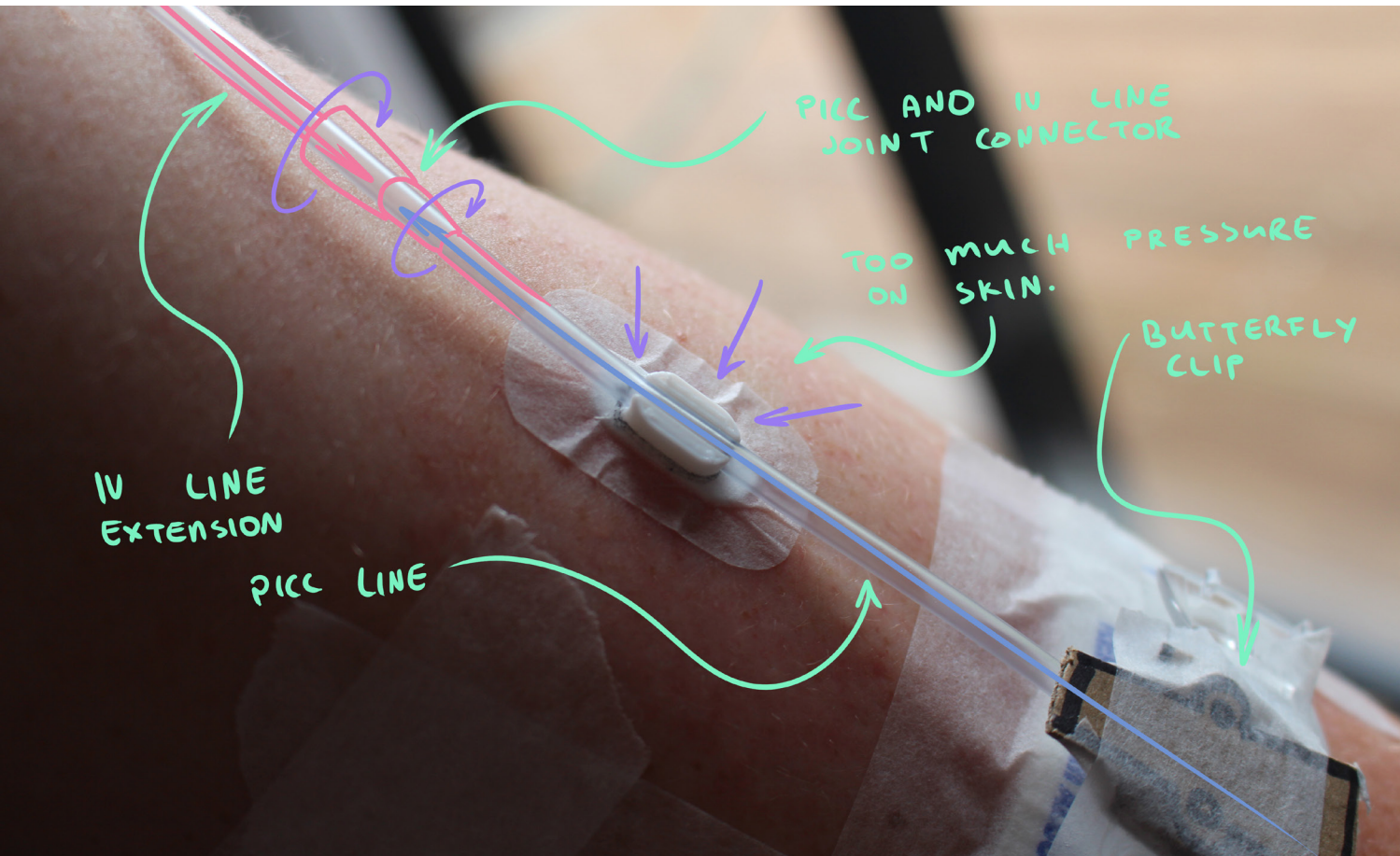


Figure 116. A small press fit IV-clip prototype. The shape of the IV clip allowed for adequate contact with the IV line. However, the clip contact patch with the user's skin was too small and did not hold the line securely in place. When the IV line was pressed into the clip, it dug into the skin and caused significant discomfort. I decided to explore a larger size for the IV clip to ensure a secure fit and avoid any patient discomfort.

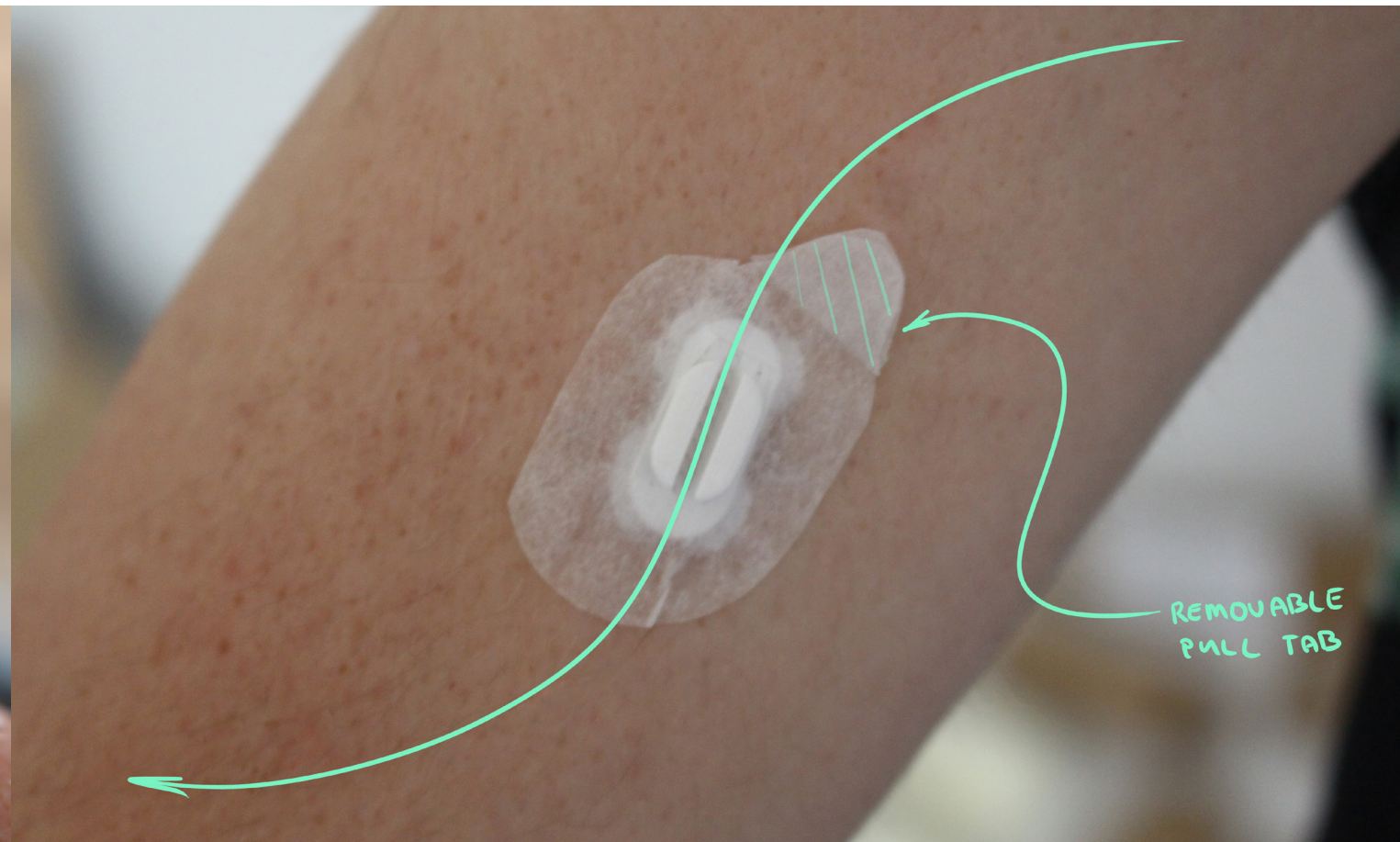


Figure 117. This idea explored using a non-adhesive pull tab to help aid in the removal of the clip after use using the same clip as the last concept. After this initial concept, I decided not to pursue the use of a pull tab further as the clip needed to stay in place for a week of treatment and a tab could lead to the clip being removed accidentally. The clip system needed to be intuitive (patients should understand how to use the clip with minimal instruction), and a patient should not think they were meant to remove the clip themselves.

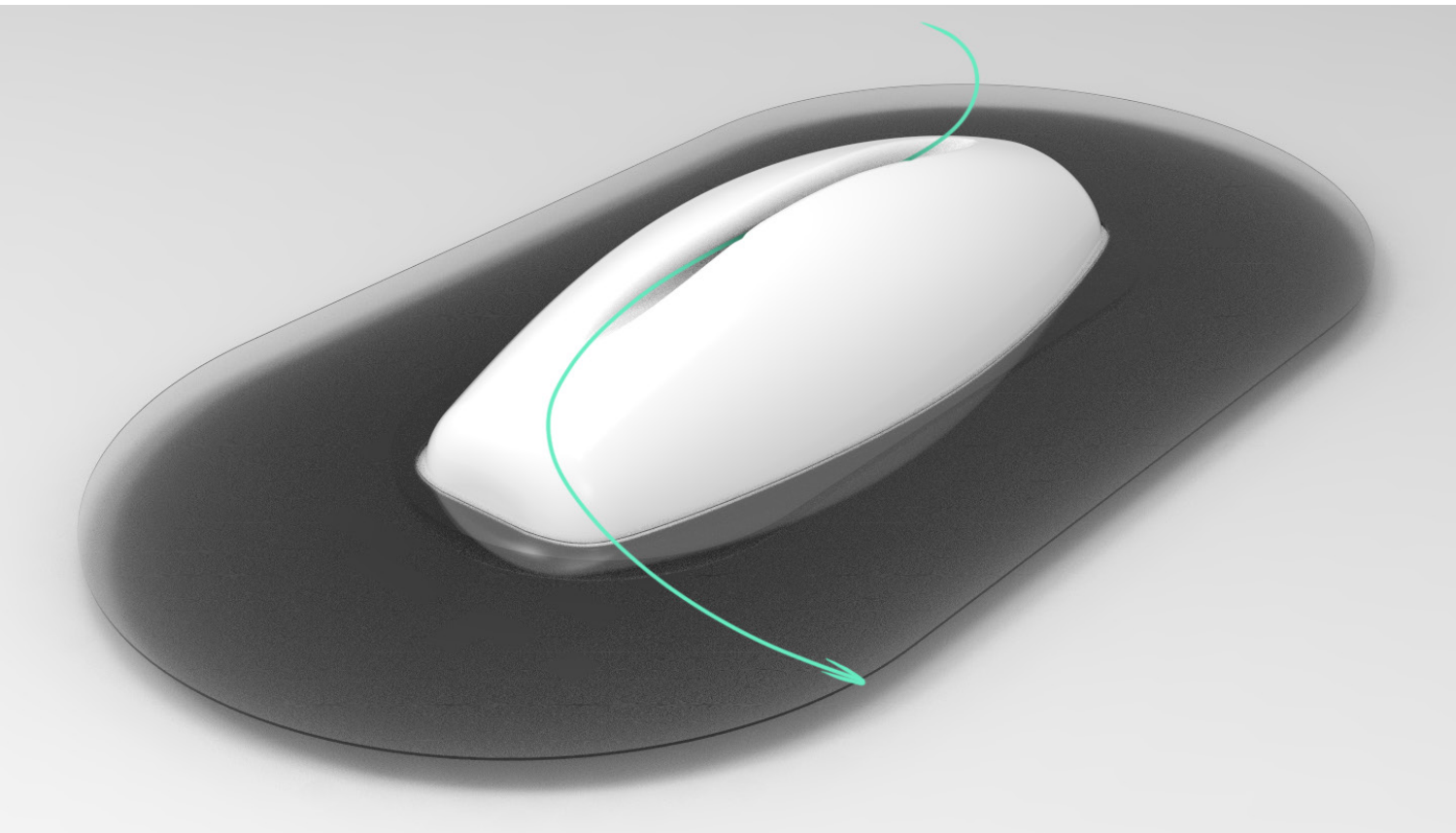


Figure 118. CAD exploration of sizing and form. The refined concepts also featured the inclusion of a concave base to allow them to fit better on the skin.

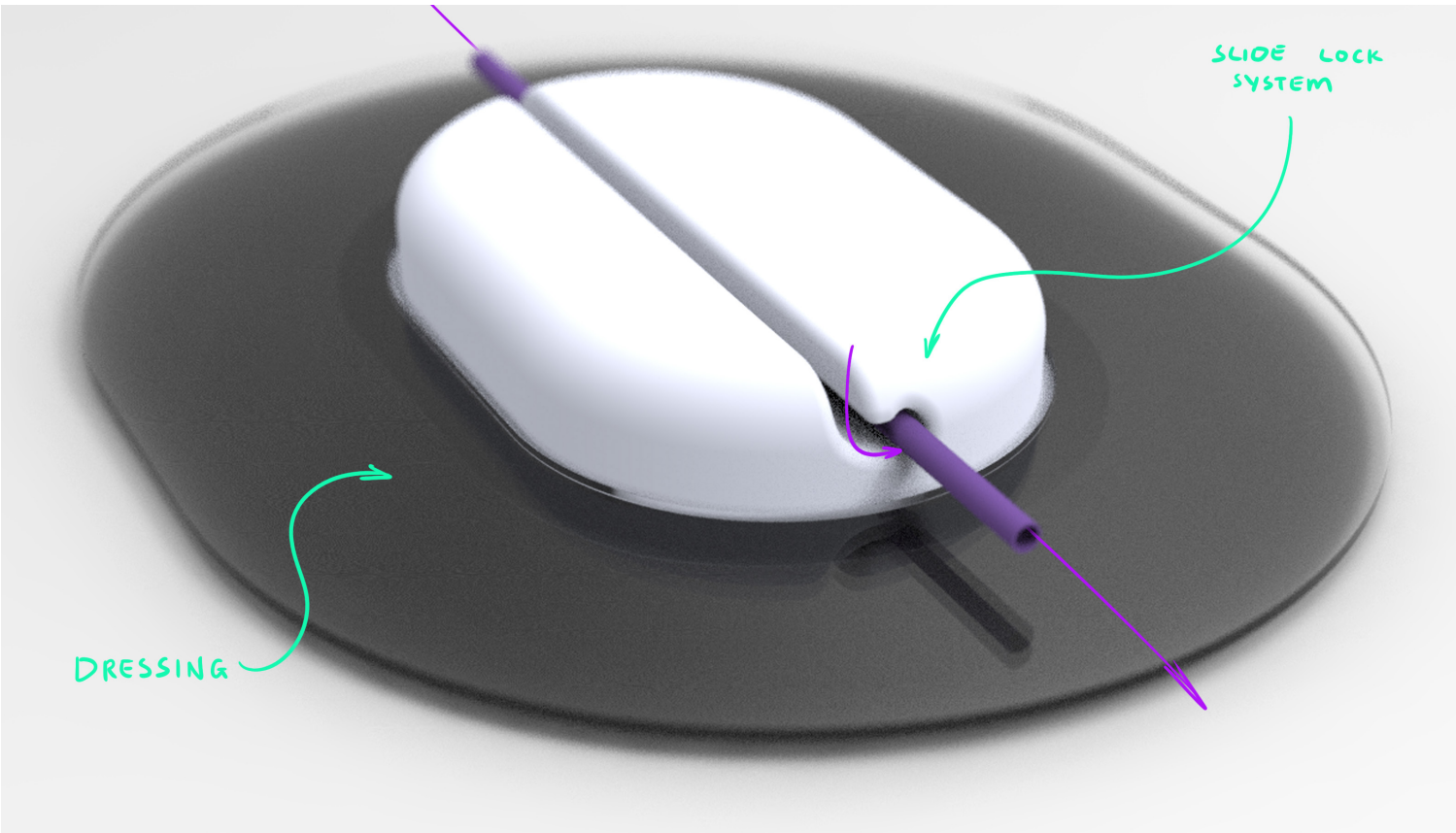


Figure 119. A second version of the multi-piece concept. I found through testing that having a single direction slot for the IV line tended to not hold the IV line securely, especially during sleeping. To avoid this, I decided to explore using a two-directional slot system to test if this held the IV line more securely. I moved away from the overall curved form because a more regular shape would allow for a more secure fit with the IV-line and a lower profile form.

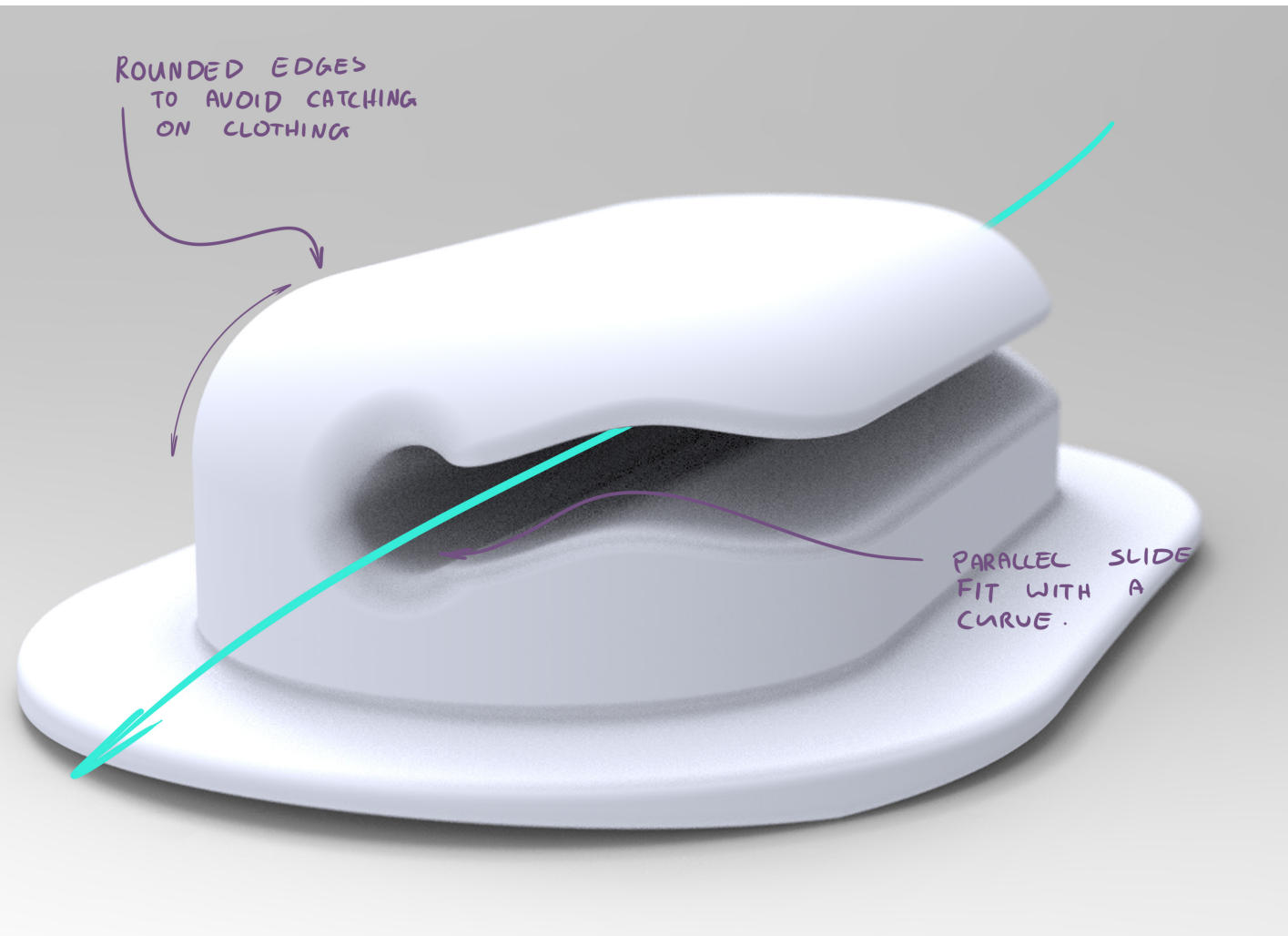


Figure 120. Building on my prototyping, I wanted to explore a horizontal slot orientation. The main benefit behind a horizontal slide fit system was the lack of pressure fitting the IV line to it placed on the patient's skin. However, this needed to be combined with a strong adhesive to hold the clip in place.

The horizontal slot clip put the least pressure on the user's skin and held the IV line the most securely. Therefore, this was the iteration that was presented during the second phase of expert critique sessions.

Multi-Piece Concept

The second concept explored used a single IV clip (rather than several different clips). This clips allowed the IV line to be routed through a specific path. Initially I explored this clip along with a built in PICC line stabilization clip.

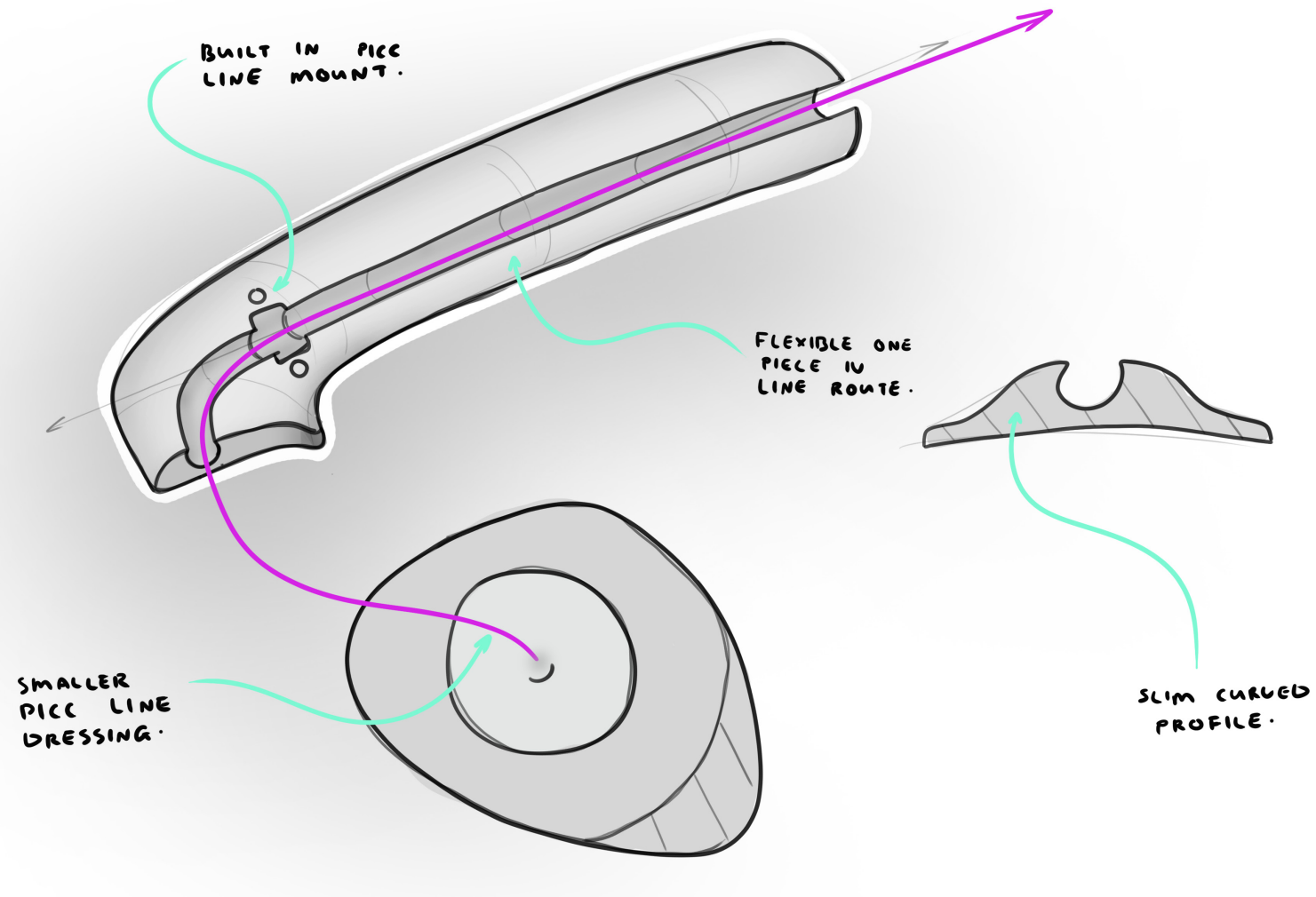


Figure 121. The second concept I developed based on the IV-clip evaluation matrix was the single piece IV clip system. This concept acted more as an IV-line routing system rather than solely a clip.

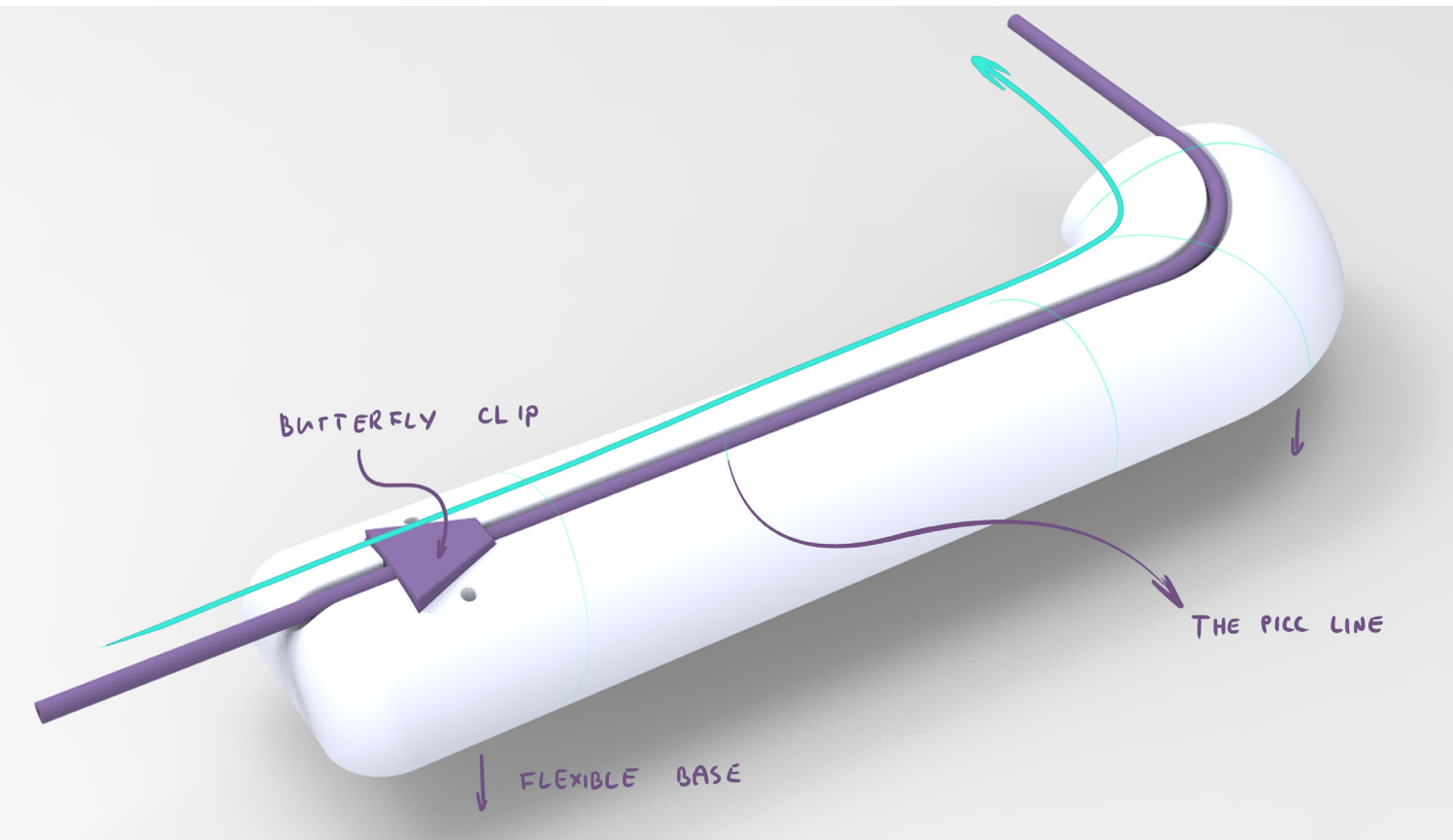


Figure 122. Further exploration of the second concept in CAD. I decided not to explore this option further as if the PICC line and IV line were mounted to the same part; there was a risk the patient could remove both accidentally, an issue this system should avoid.

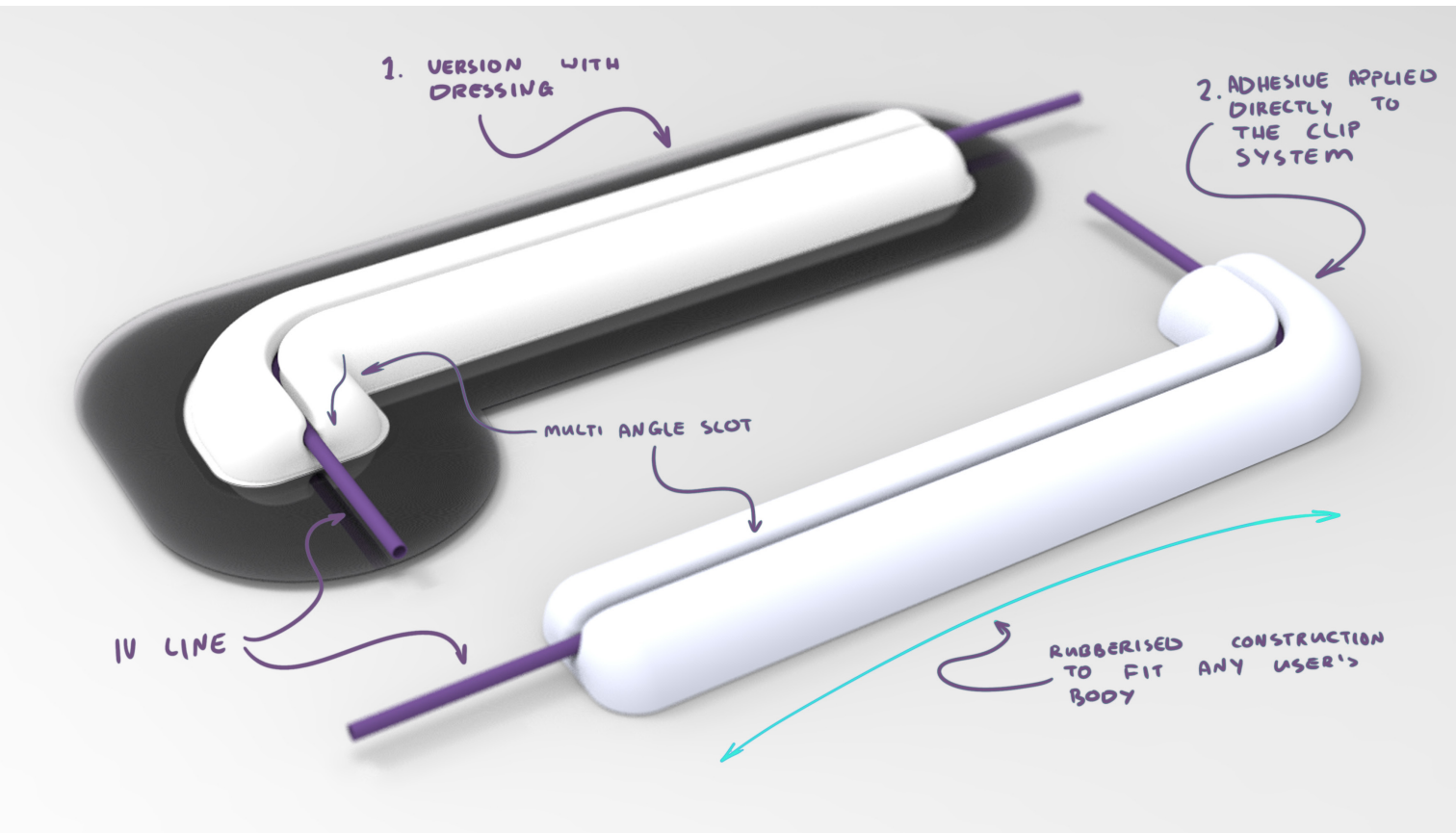
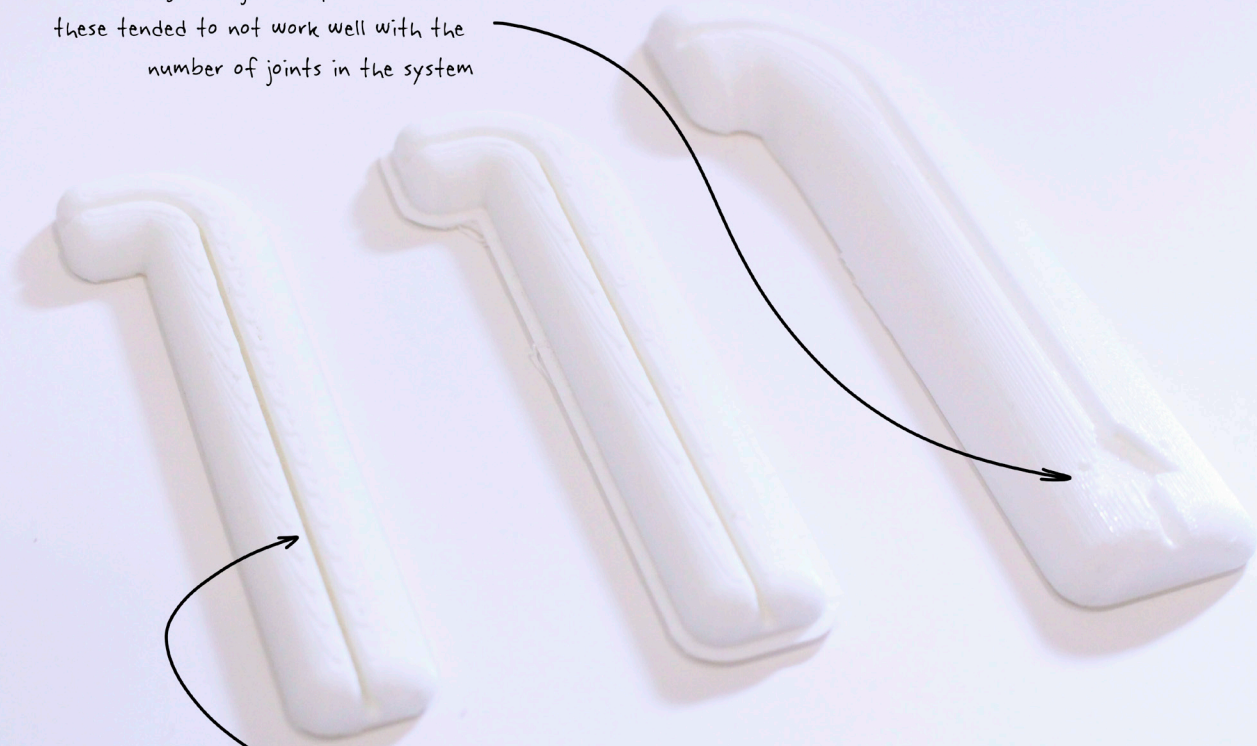


Figure 123. Based on my testing with the first refined IV clip concept, I found that a single direction slot for the IV-line would not hold the IV-line securely in this form. This concept used an 'S' shaped slot. Two designs were explored using either a separate dressing mounted to a flange (dressing shown) or an adhesive applied directly to the clip base.

although IV joint clips were tested these tended to not work well with the number of joints in the system



some of the prototypes featured slots which were too tight to fit the IV line

Figure 124. IV line clip prototypes exploring scale and form.

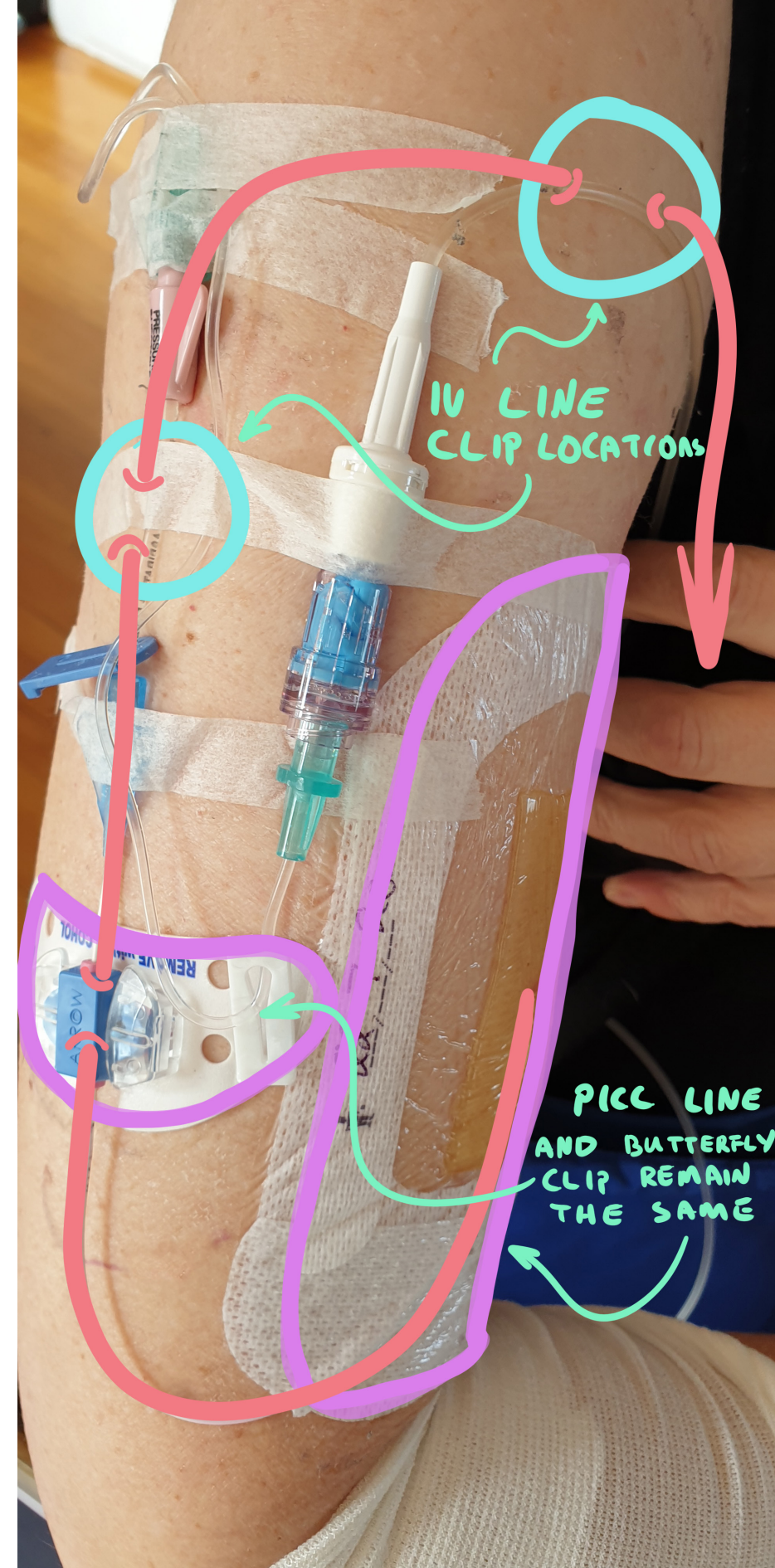


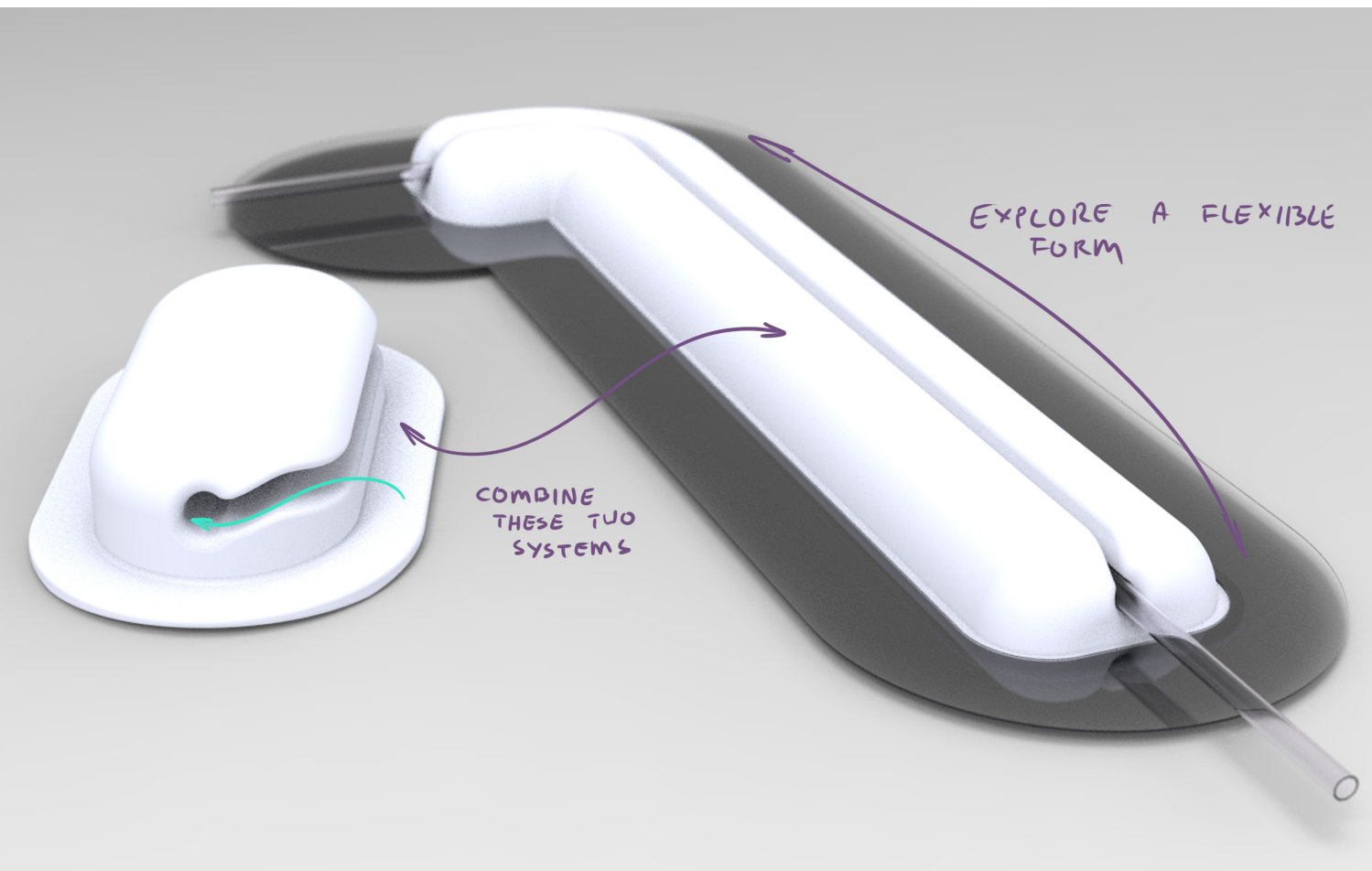
Figure 125. Follow the testing of rigid prototypes, I explored prototypes made from more flexible materials. Two versions were printed with different forms to explore how these would affect flex in the system. Based on these explorations, I found that using a flexible material allowed for a better fit on the patient's skin; however, this was at the sacrifice of a secure fit on the IV line.

Reflection

IV Clip discussion: Which Elements Should Change and Which Should Remain?

Based on initial explorations, I decided to maintain the existing placement of the PICC line lock (stabilization clip) and the primary dressing (*Figure 126*). There was evidence to suggest improvements to these systems were needed (e.g. either due to allergic reactions caused by the dressing or PICC line migration during dressing changes). These issues were often associated with clinical staff errors or accidental adverse medical events (Hitchcock & Savine, 2017). None of the participants I spoke to experienced significant problems with these parts of the system (one participant mentioned they broke the PICC line stabilization clip). Because this research aimed to improve the patient experience in the OPIVA service, I decided to avoid changing the existing PICC line dressing and PICC line stabiliser. From this point onwards in the research, the IV clips would be used to replace the role of the surgical tape used in the existing system while keeping the existing PICC line stabiliser and sterile dressing.





Based on the IV clip system exploration, two versions were developed further and presented to users in the second set of expert critique sessions. These selections were based on my insights, prototype tests and on adherence to the requirements set out in the design brief. The rigid flanged version of the one-piece IV clip was selected as the larger replaceable dressing allow for a more individual fit depending on the user.

Figure 127. Final IV clip concepts presented to users during the second expert critique sessions.

Second Expert Critique

Expert User, Previous Patient and OPIVA Nurse

Although having multiple clips allowed for choice around placement, both patient participants preferred the single part system as this kept the process of storing the IV line simple. In addition, both participants preferred slotting the IV line in from the side rather than from the top. They also felt that having a slightly more ergonomically shaped or flexible system to fit the user's arm would be better than the rigid, straight one-piece concept. Therefore, the subsequent steps of the creative process around the IV clips involved refining the form and function of the single-piece IV clip to reflect these insights.

The OPIVA nurse reacted negatively to the IV clip concept. They expressed that although the taping system was frustrating for the users to use, it was cost-effective and did not negatively impact patient health outcomes. They also highlighted that it was likely that the IV clip would be more costly. Bearing this in mind, I decided to keep pursuing the clip system as this was an area that all patient participants had commented on as a problem. For my product-based outcomes to best represent the user's experiences, I needed to highlight all their issues, even if addressing them was not as cost-effective as the existing system. It would be unlikely that the IV clip system would be adopted if this system were taken to market, as the IV clips would likely increase costs too much and could present too radical a change to the existing system (West, 2020).

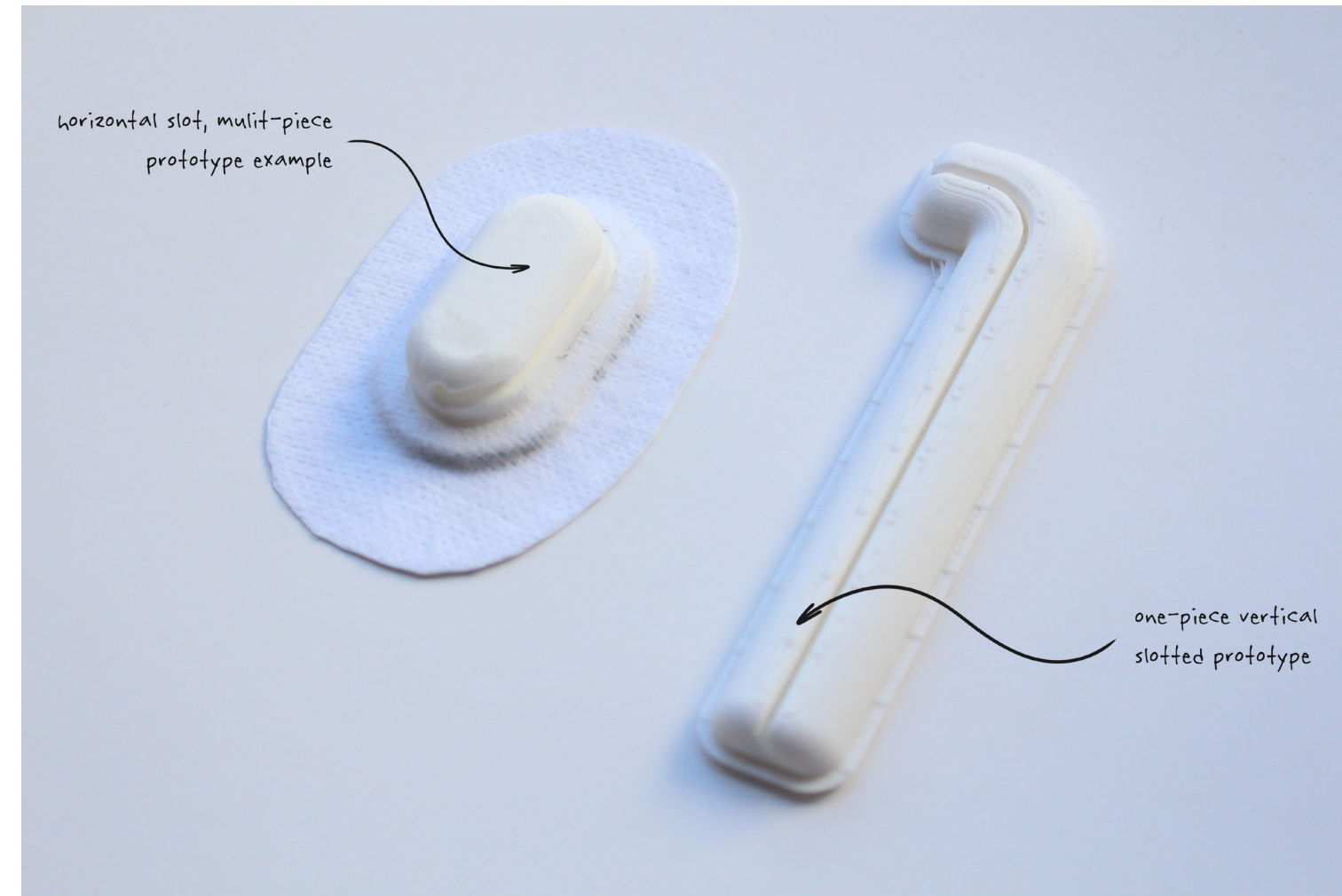


Figure 128. The IV clip concepts presented to the expert critique session participants.



Mood board images removed for copyright reasons.

Figure 129. Exploration of material choice and aesthetics mood board. I decided to use consistent design language across the whole system. Achieving a consistent aesthetic meant using materials that worked well together and supported a consistent form language across the entire ecosystem of products.

Ideation Based on the Second Expert Critique

Upon further consideration of the Baxter guidelines, I was reminded that the flow restrictor needed to be mounted directly to the skin to ensure it was kept warm to keep the flow rate steady. As a result, I decided to move towards a clip for the IV-line connectors instead of the IV line. I found that in testing, having the joints slide into the connectors parallel to the IV line was the most effective system.

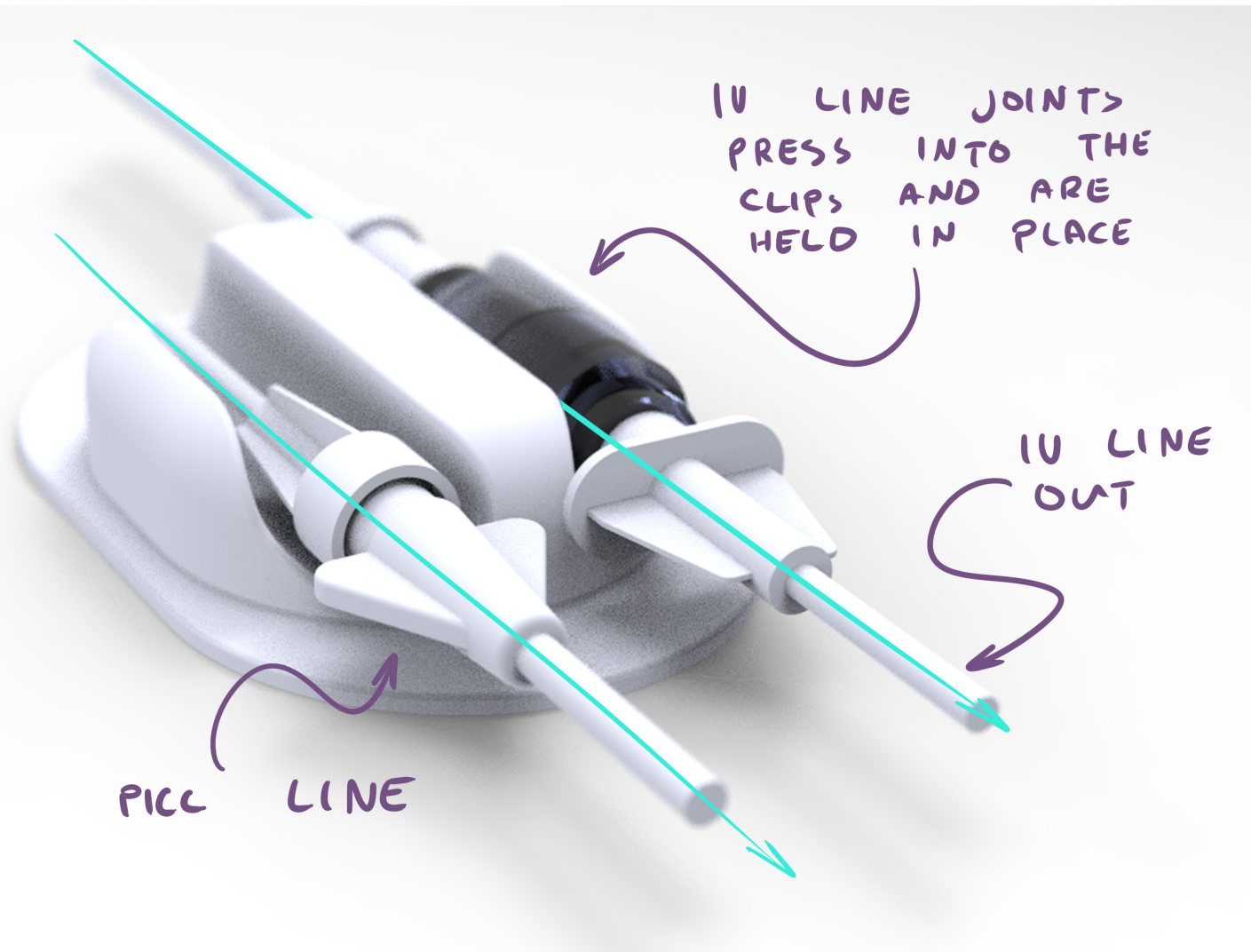


Figure 130. CAD illustration showing how the IV joints could be slid into the IV-line holder. The two main joints (the join between the PICC line and IV extension; and between the flow restrictor and the IV extension) were held in place with one clip to reduce the system's complexity.

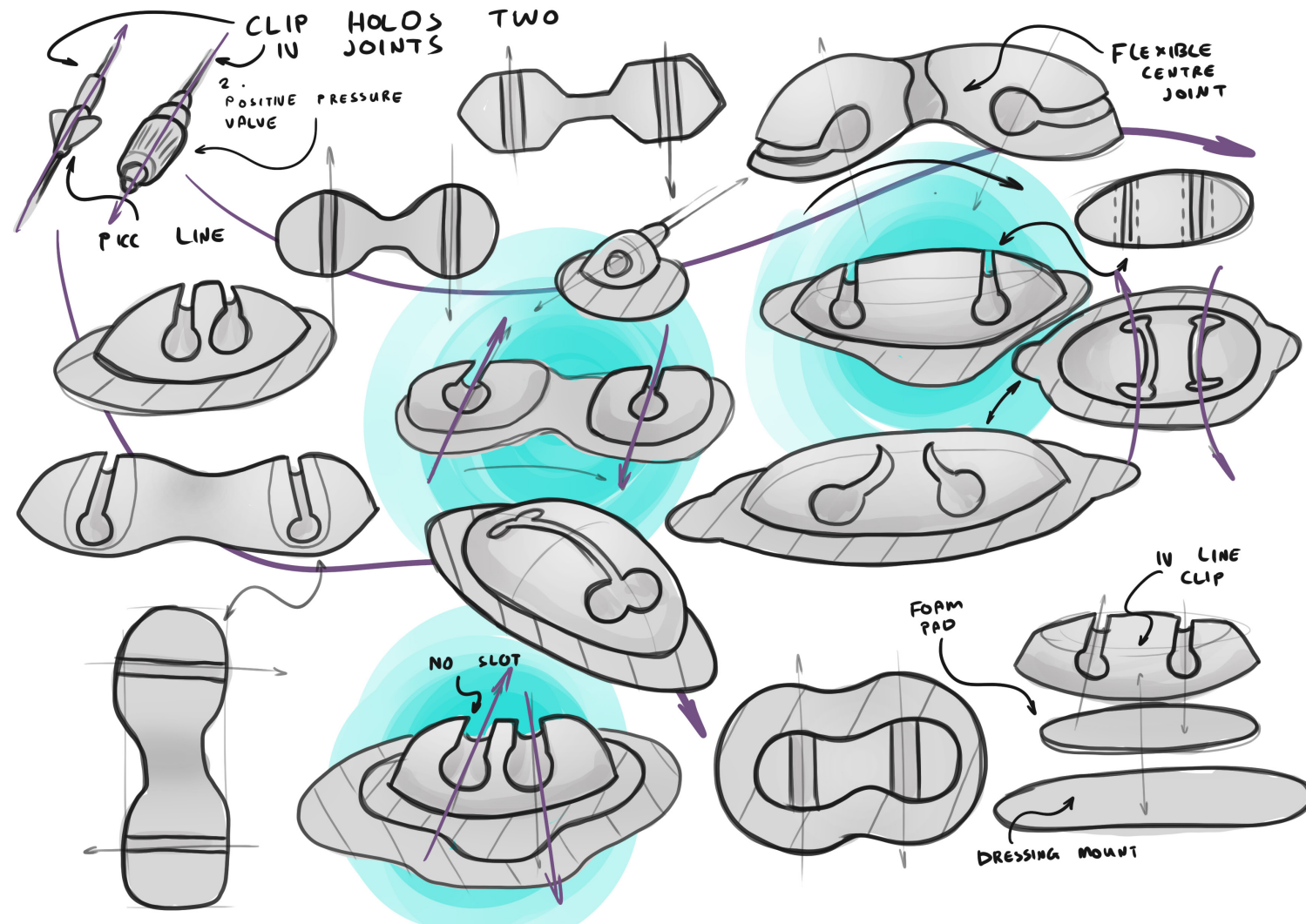


Figure 131. Exploration of the form of the IV-clip system. The three most successful options (highlighted in blue) were chosen based on their aesthetic appeal and their function based on the requirements of the IV clip system defined in the design brief.

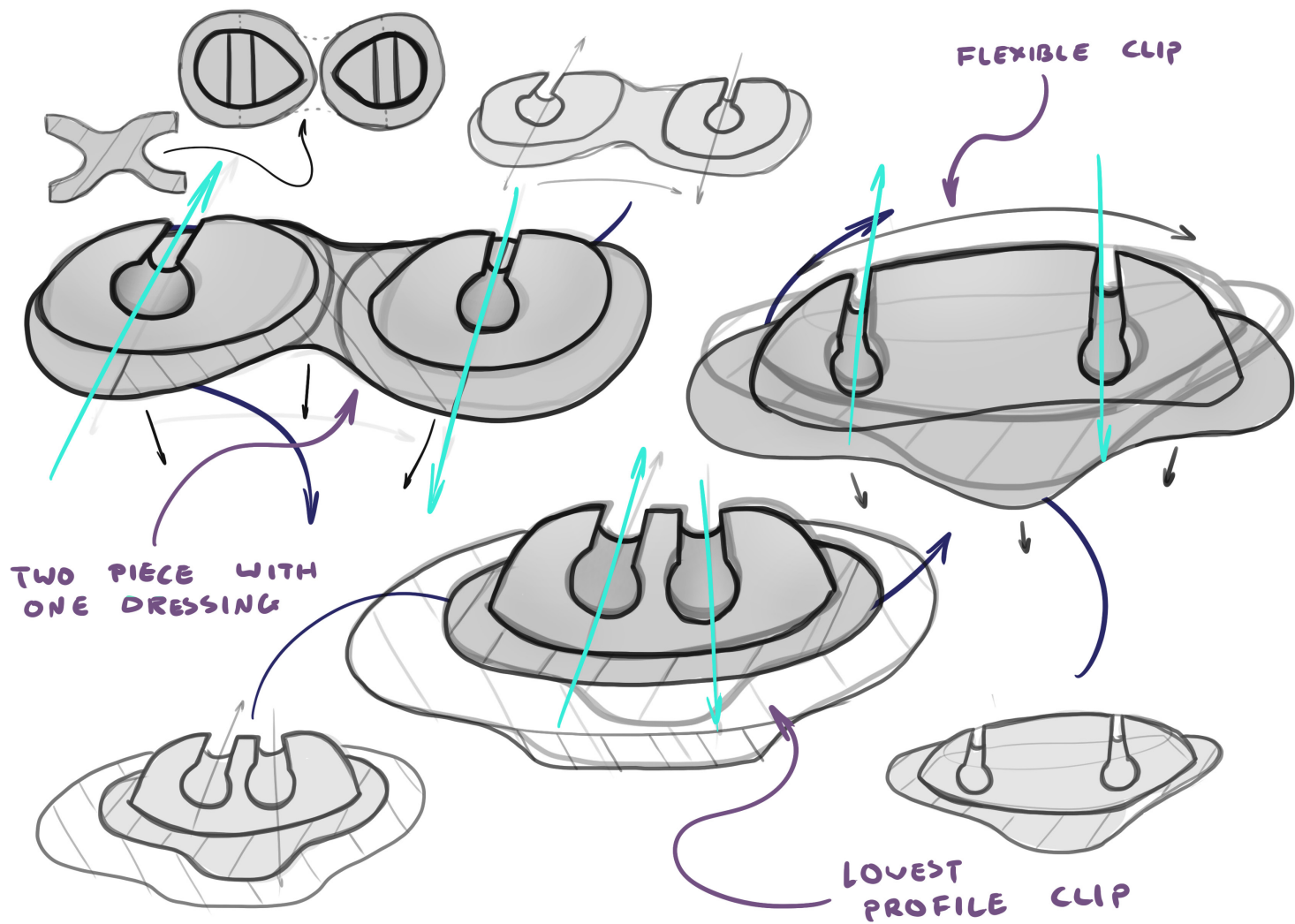


Figure 132. The three most successful designs were explored and developed further through rapid sketching. Each design featured the same IV joint clip system (a simple slide fit system for the IV-line connection joints) but differed on the spacing and placement of these slots. These designs were explored further through CAD modelling and prototyping.

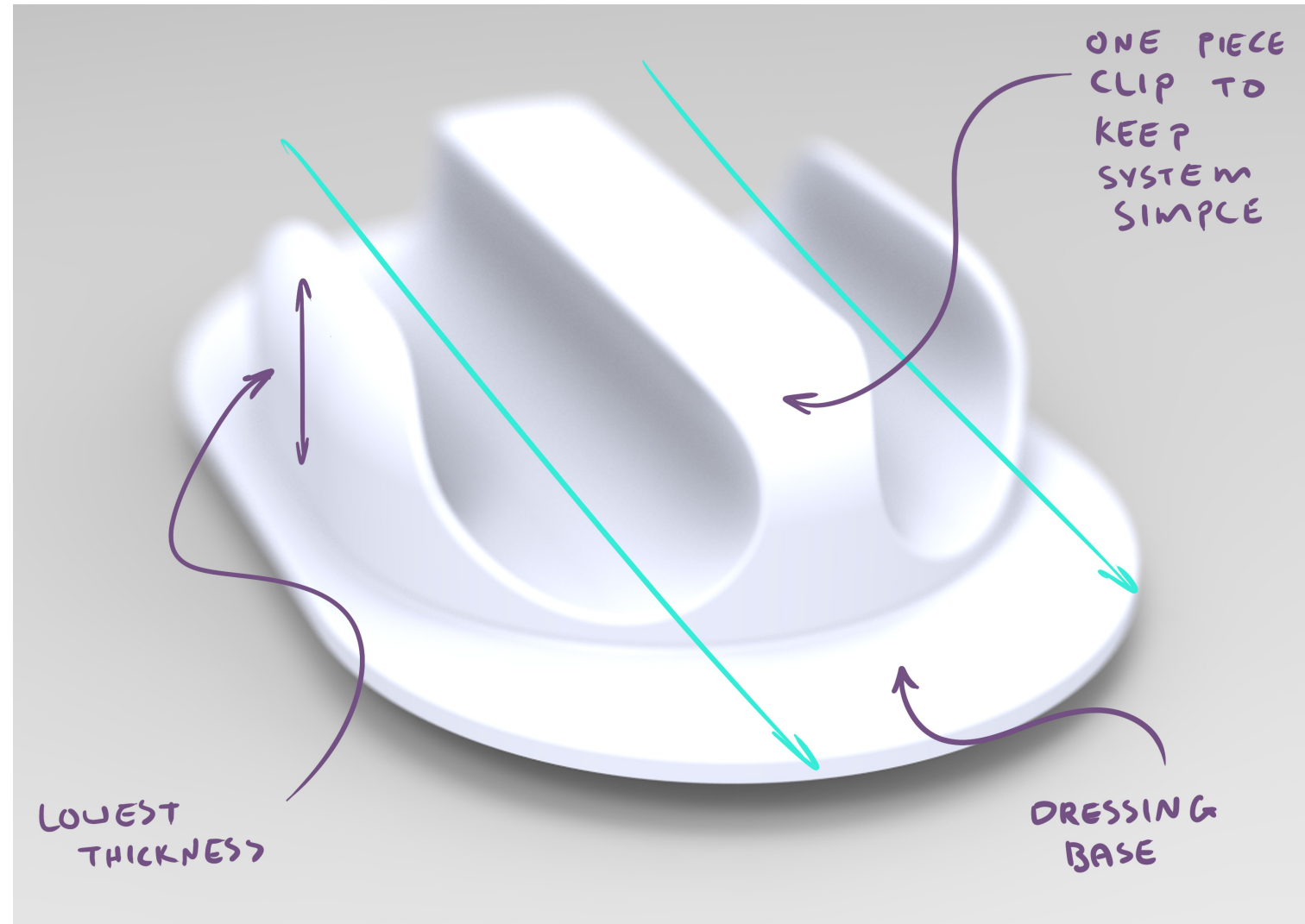


Figure 133. Following the sketches initiated by the second expert critique, I explored each of the three designs through CAD. The first concept featured a thinner overall width with a longer length to support the IV joints with a smaller size.

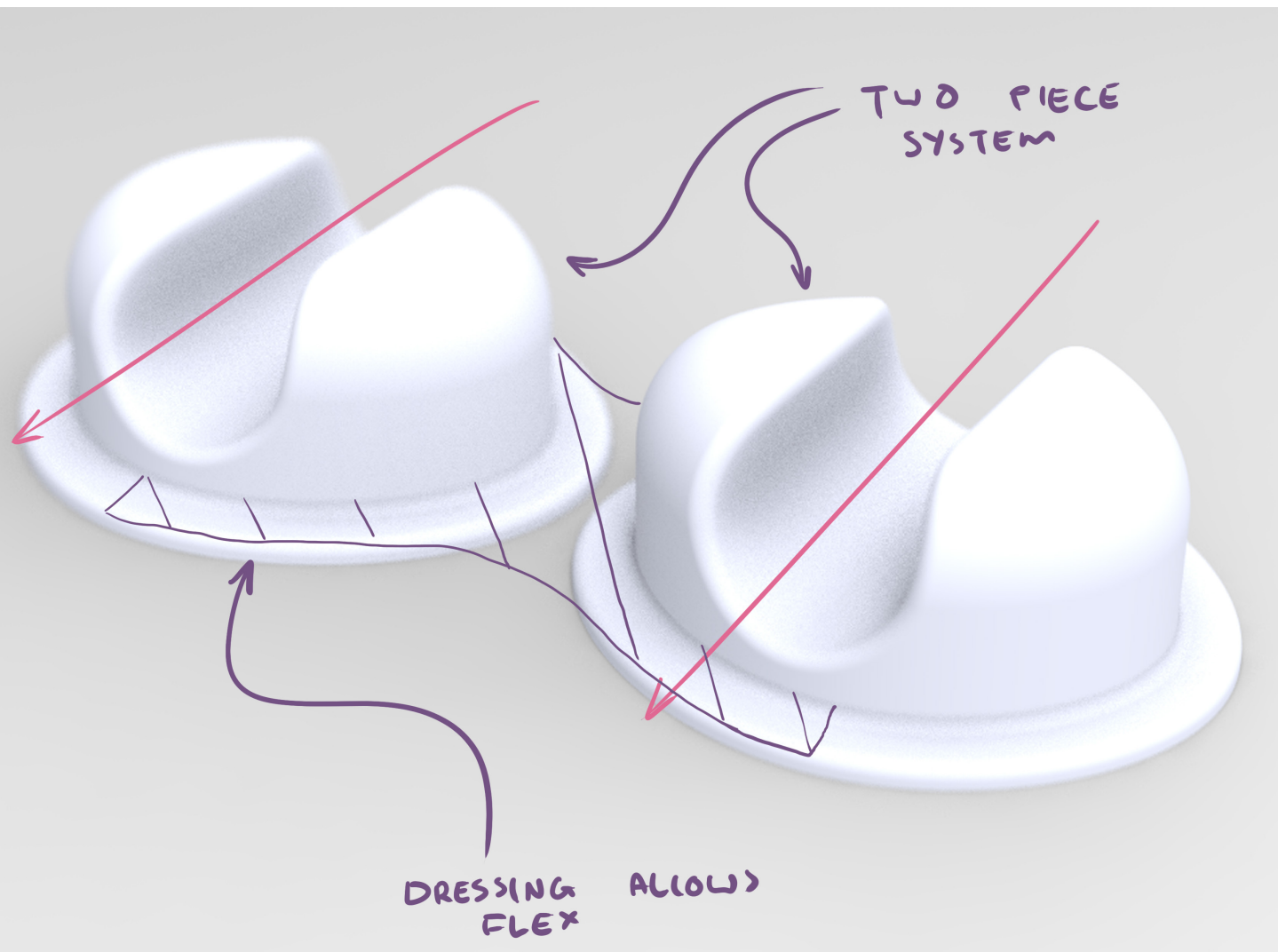


Figure 134. This concept used two pieces joined with a dressing to create a flexible joint.

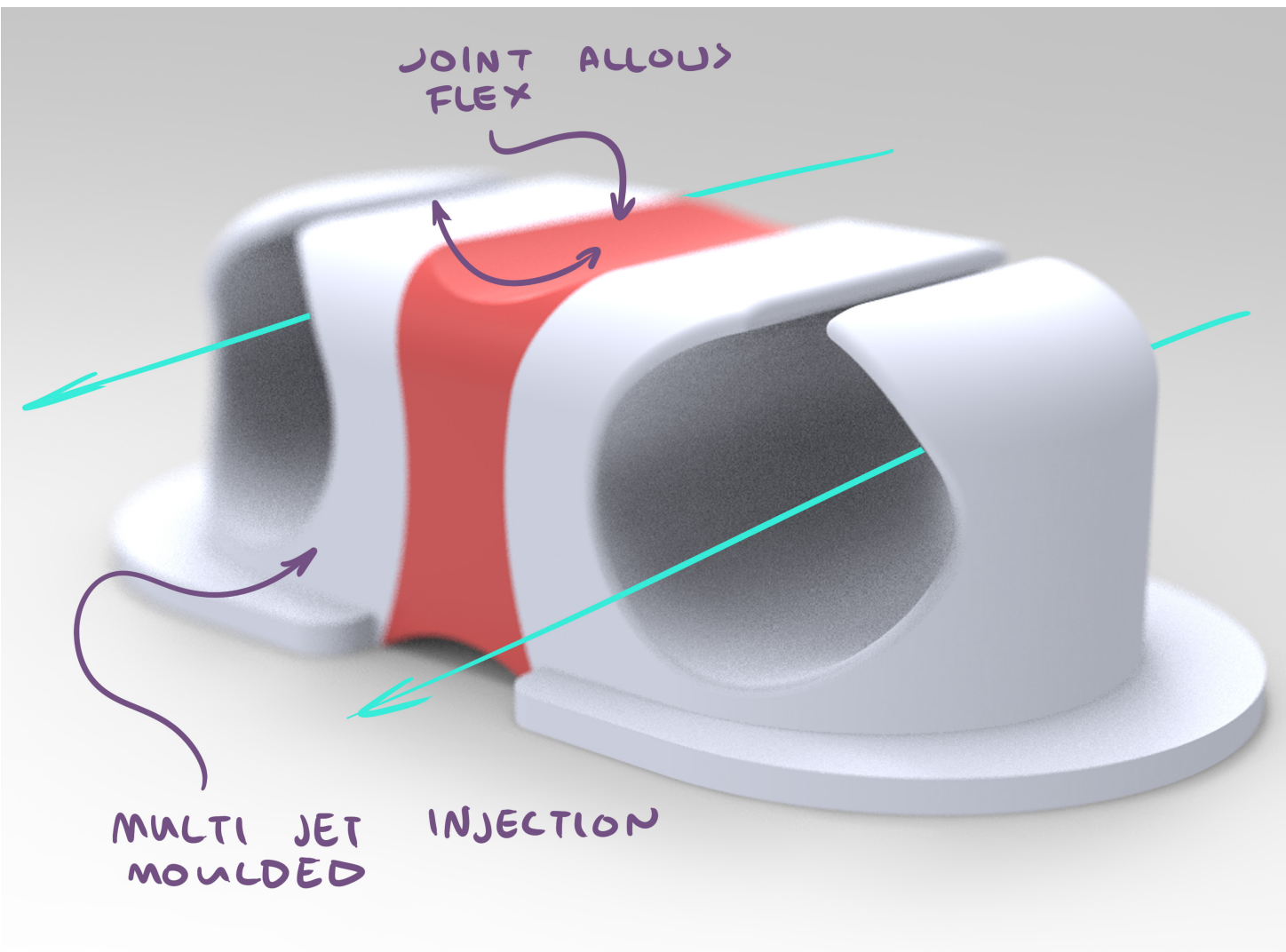


Figure 135. The final concept featured a larger width than concept one but a thinner contact point with the IV joints. This concept would use a double shot injection moulding process to create a flexible centre.

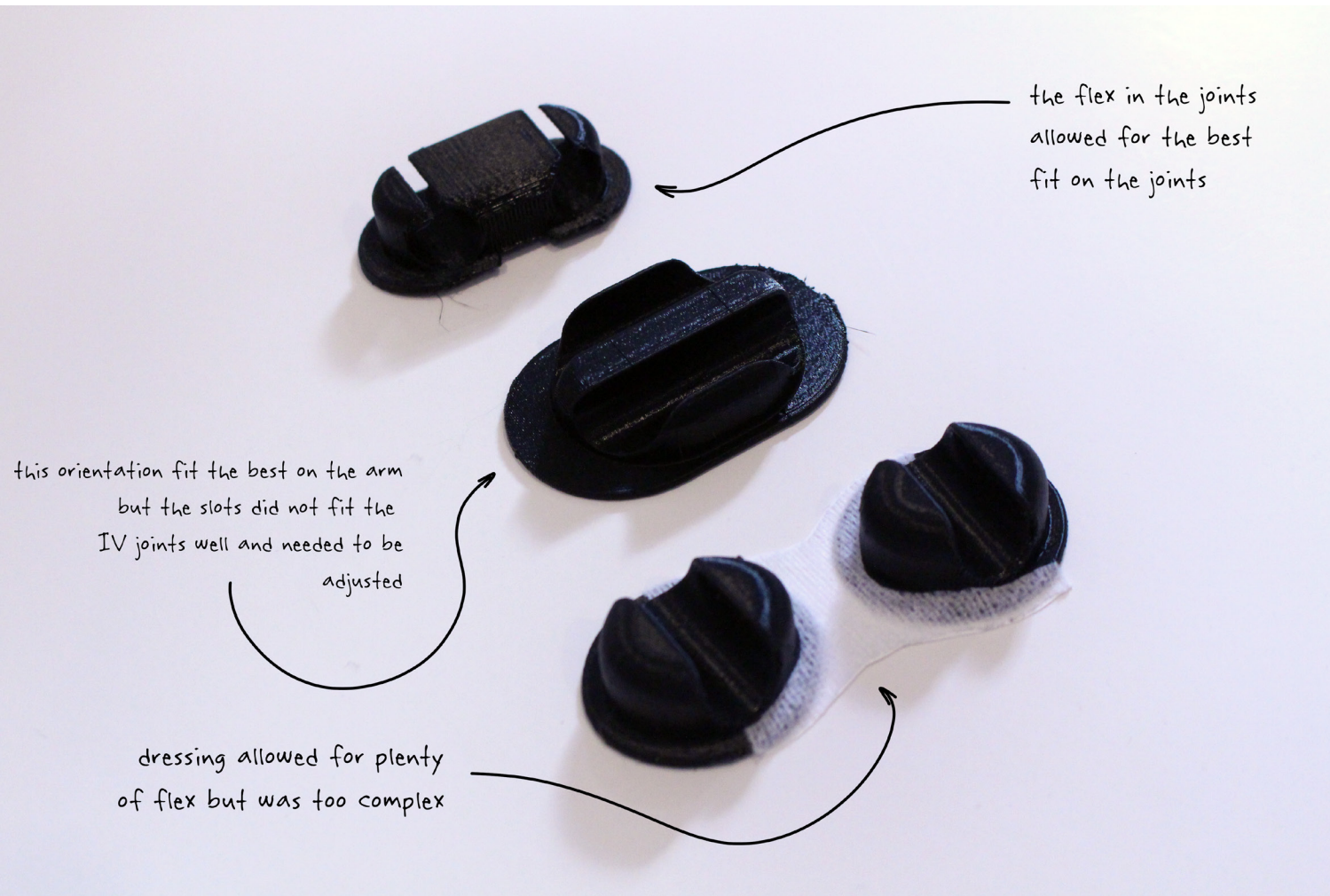


Figure 136. IV clip prototyping exploration.

	CONCEPT 1	CONCEPT 2	CONCEPT 3
secure fit	9	7	8
comfort on skin	8	8	6
use with one hand	7	6	7
compatibility with IV	8	5	6
ergonomic form	8	8	6
	40	34	33

Figure 137. Evaluation of the three developed IV clip solutions based on the design brief specifications. Each was tested with 3D printing to ensure function along with CAD models.

Each IV clip was 3D printed and tested to ensure they had a secure fit on the IV joints and fitted comfortably on the user's arm. Concept's two and three were both comfortable, and the flexible designs meant they fitted a wider range of arm sizes. However, both required more complex systems, which would increase costs and could result in users losing or breaking parts. Based on these insights, concept one was the most successful option.

However, there were still some issues with the first concept. The first concept (the single piece concept without a joint) was too long and did not fit comfortably onto the patient's upper arm due to its lack of curvature. As a result, a second version of the clip was designed featuring a reduced overall size to better fit the patient's arm along with a two-way curved base. In addition, this concept would be glued to a foam dressing base like the stabilization clip to give a secure fit on the patient without causing any pressure spots.

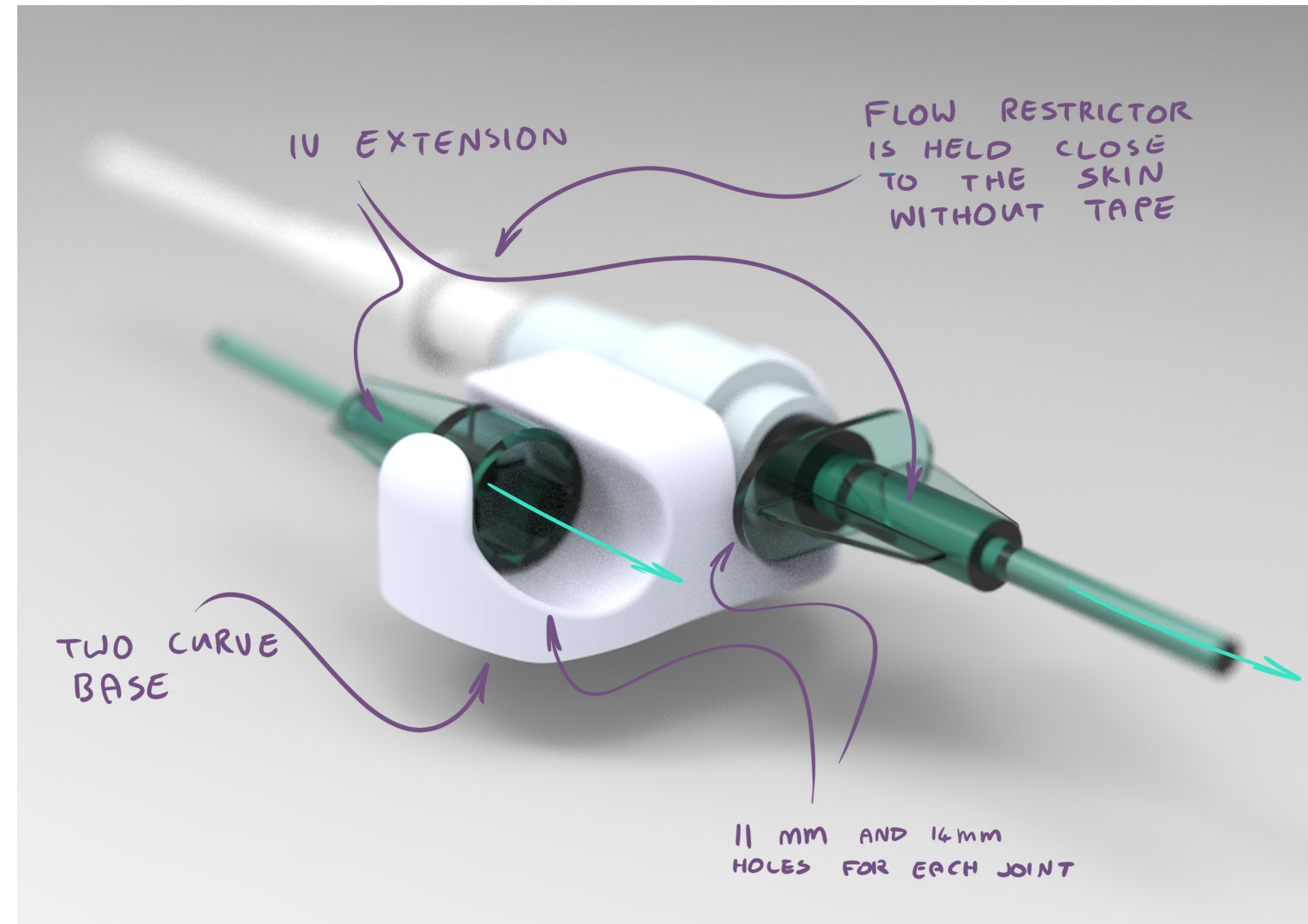


Figure 138. The refined version of the IV clip based on concept one. This concept was used as a probe in the third expert critique.

Third Expert Critique

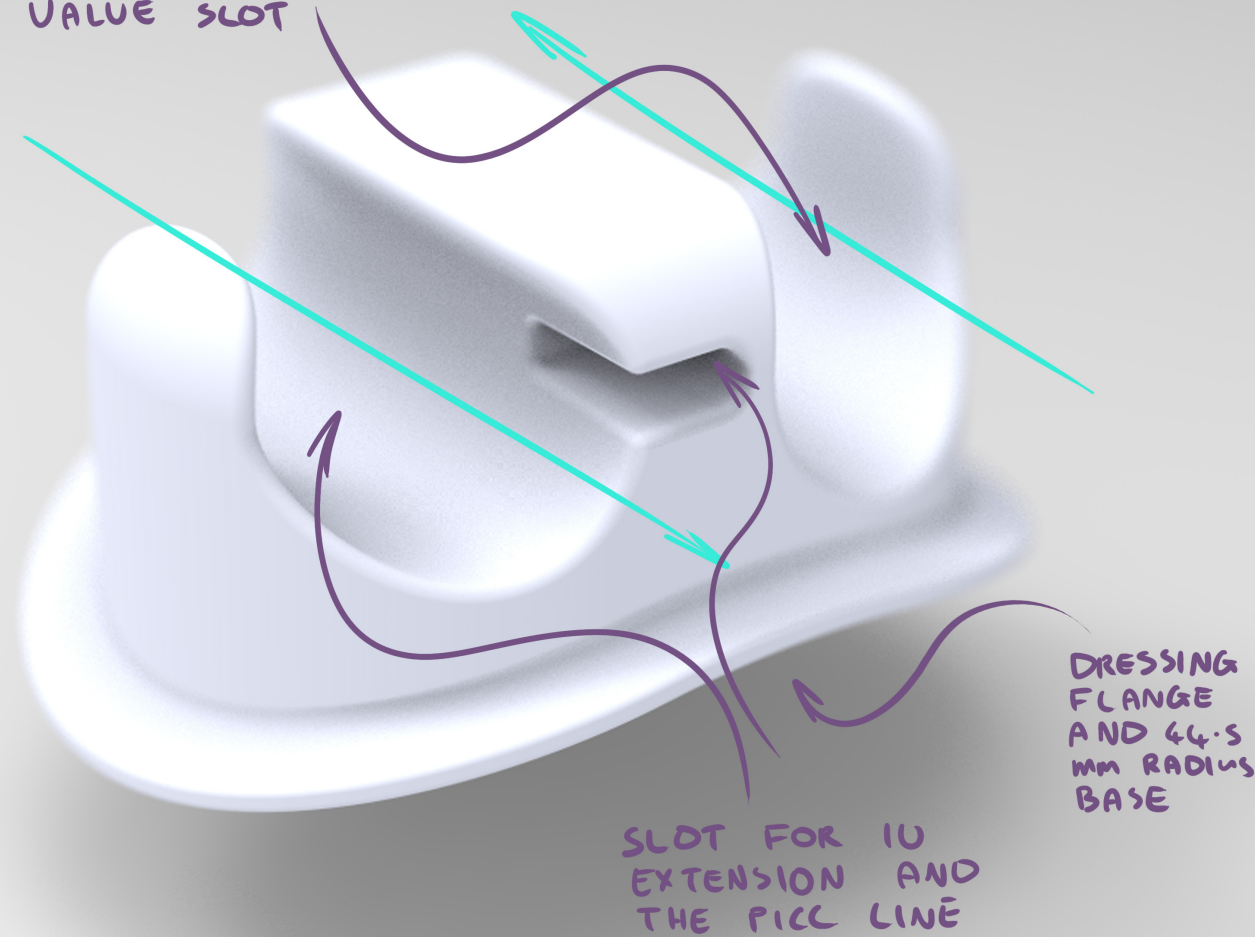
Expert User

During the third expert user critique, I presented the final refined clip concept as a single concept to gather feedback from the expert user. They reacted positively to the clip and expressed a preference for the one-piece clip over the clips that featured a joint. The participant felt that the form of the clip did not match that of the infuser well. As a result, I decided to continue exploring the aesthetics of the clip and creating a clip that could better match the aesthetics of the rest of the system. The expert user expressed interest in the fact that a clip could allow the pressure points created by the IV line joints to be spread out over a wider area.

IV Line Management – Finalising

Based on my earlier exploration of the final IV clip and the third expert critique, I adjusted the final design of the IV clip system. In user testing of the previous iteration of the IV clip, I found that the base was not sufficiently curved to fit on the patient's upper arm without a gap forming. In addition, this system featured a smaller overall size to ensure minimal pressure on the patient's skin, avoiding possible pressure point damage (Todd, 2018).

POSITIVE PRESSURE
VALVE SLOT



SLOT RESULTS
IN A BETTER
AESTHETIC
BUT IS A TALLER
CLIP

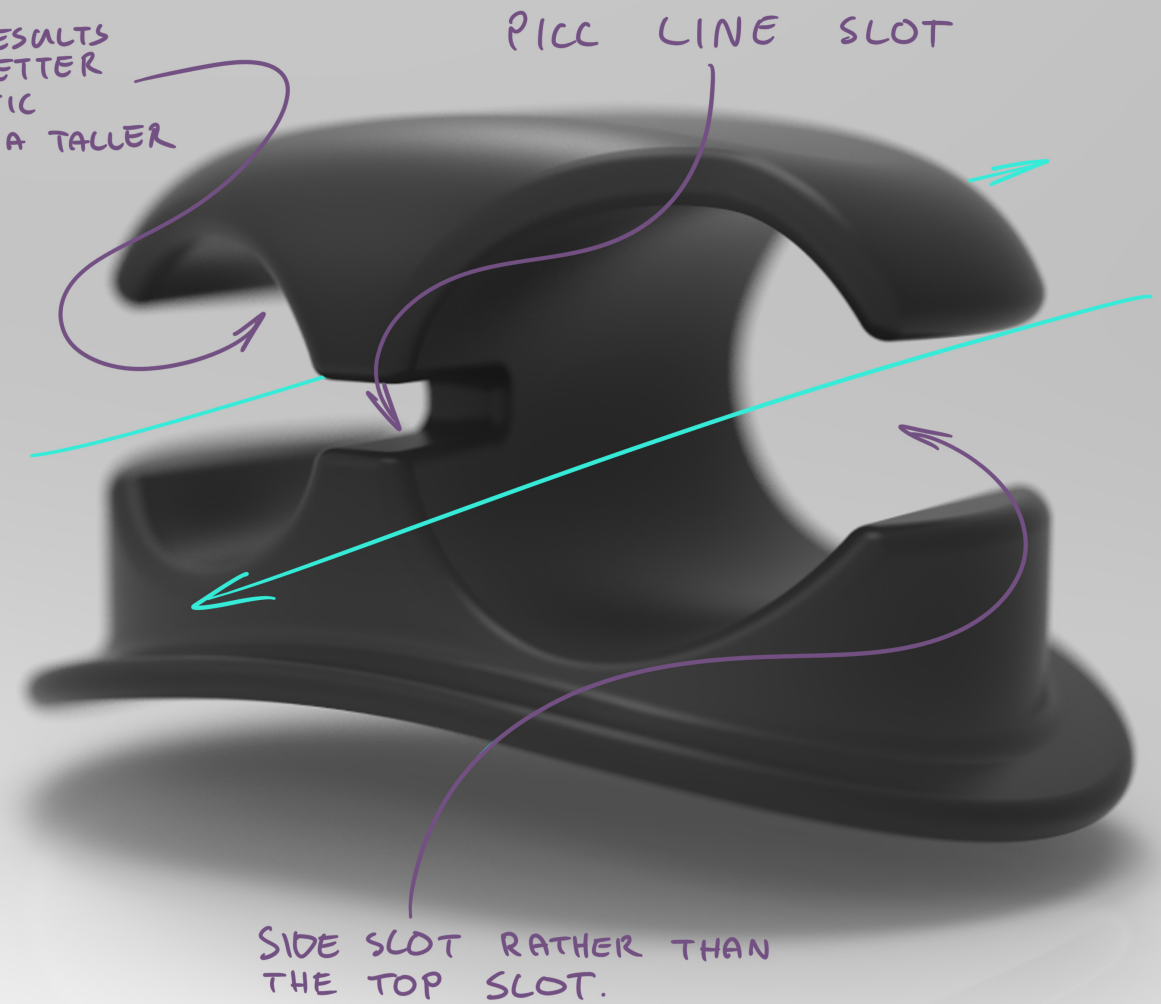


Figure 139. The IV clip design with an adjusted base curvature to fit better on the arm (44.5mm radius) and a slot to fit the PICC line more effectively.

Figure 140. An alternative design to the vertical slotted IV clip would be a horizontal slotted IV clip. However, the use of a horizontal slot adds too much overall thickness to the clip, creating more risk of catching on clothing.

After finalising the functional elements of the IV clip, I needed to consider the aesthetics of the clip. To explore this, I created various clip concepts using a similar form language to the other parts of the system. I decided to use the 'squircle' shape used in the infuser to lead the shape of the IV clip. The next step was to take these functional elements, base curvature and base shape and explore the other aesthetic elements of the clip.

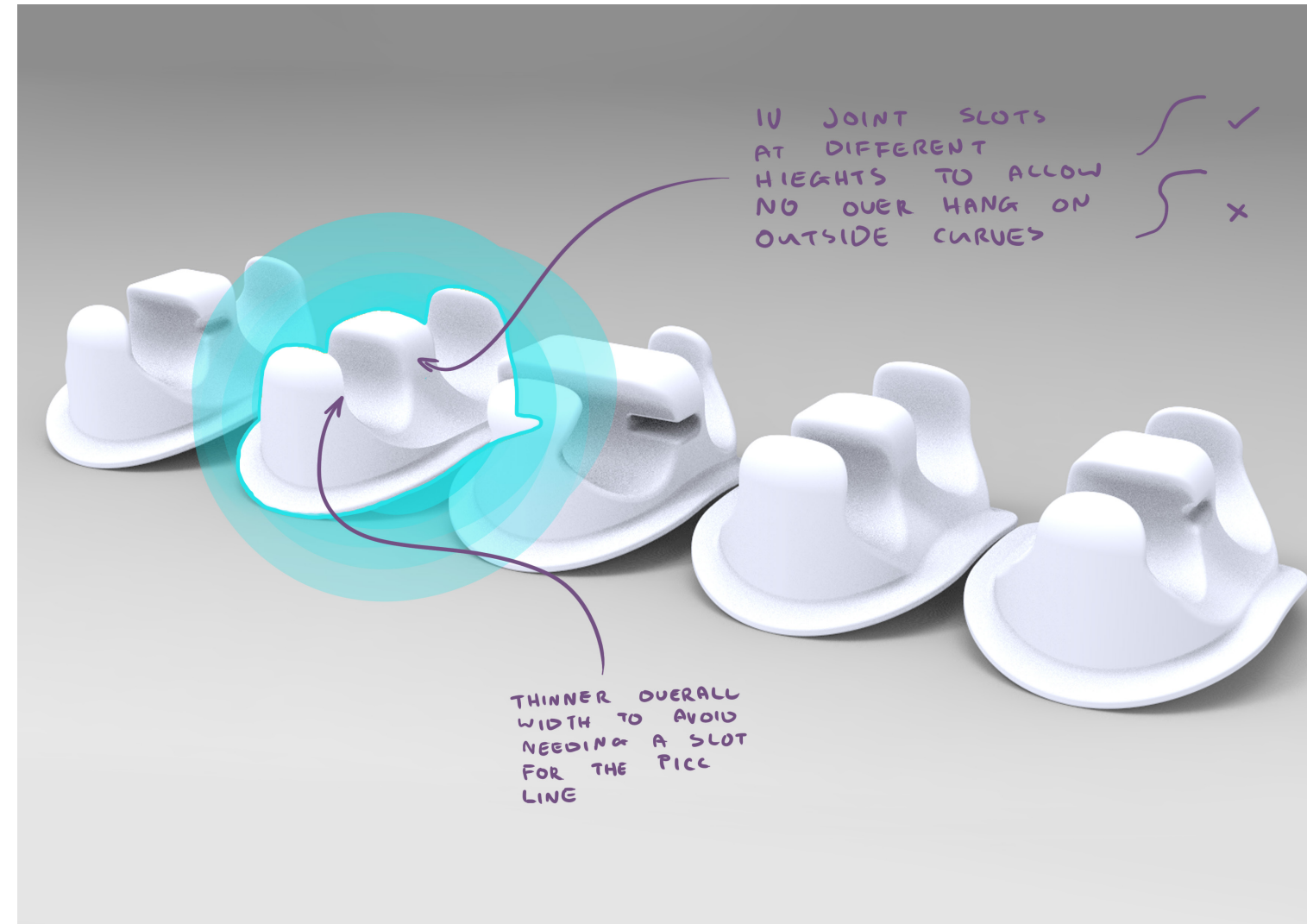


Figure 141. CAD models exploring the aesthetic of the IV clips. I felt the highlighted option was the most aesthetically successful based on these CAD models.

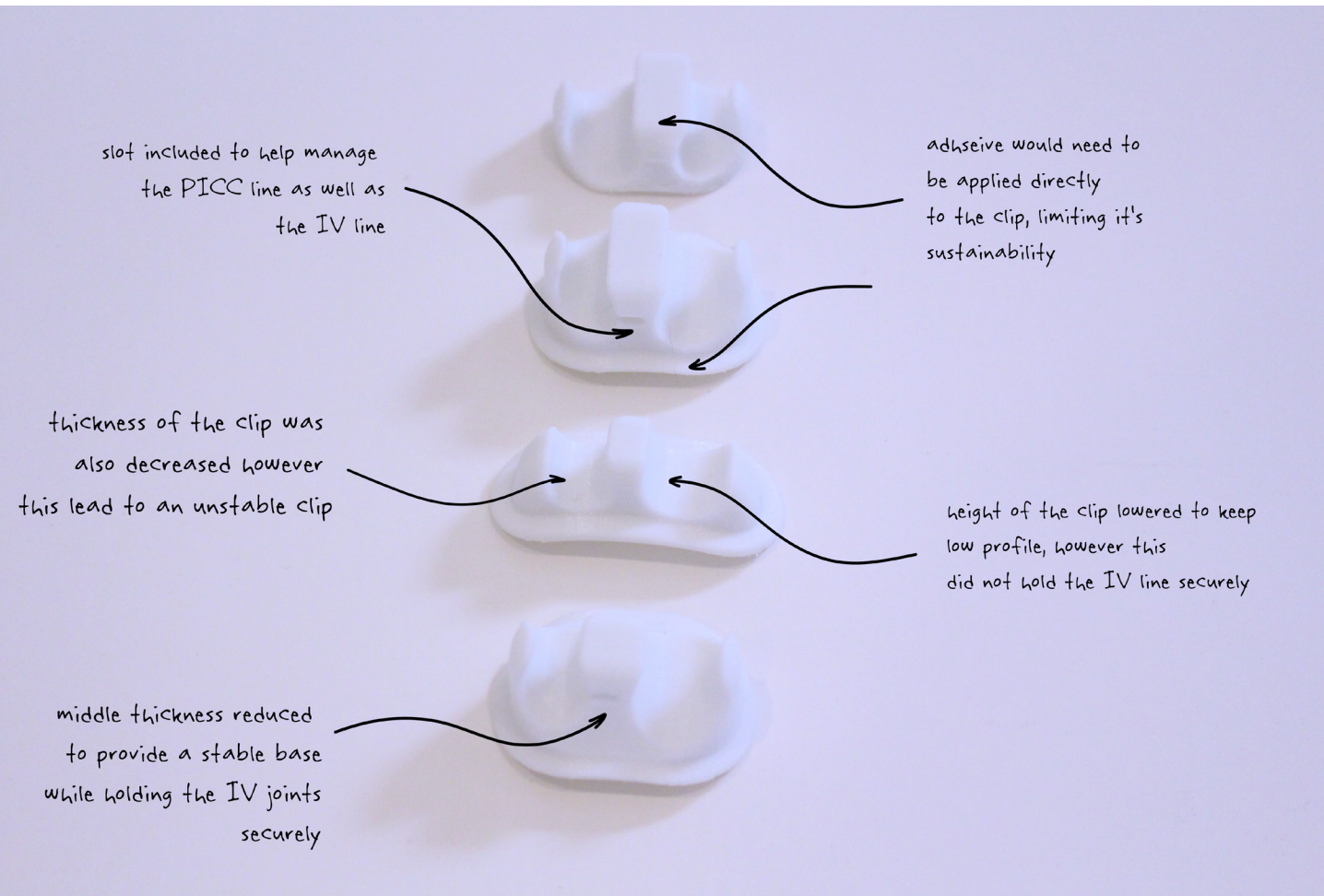


Figure 142. The IV clips were 3D printed and tested to explore function with the IV lines and comfort through user testing.

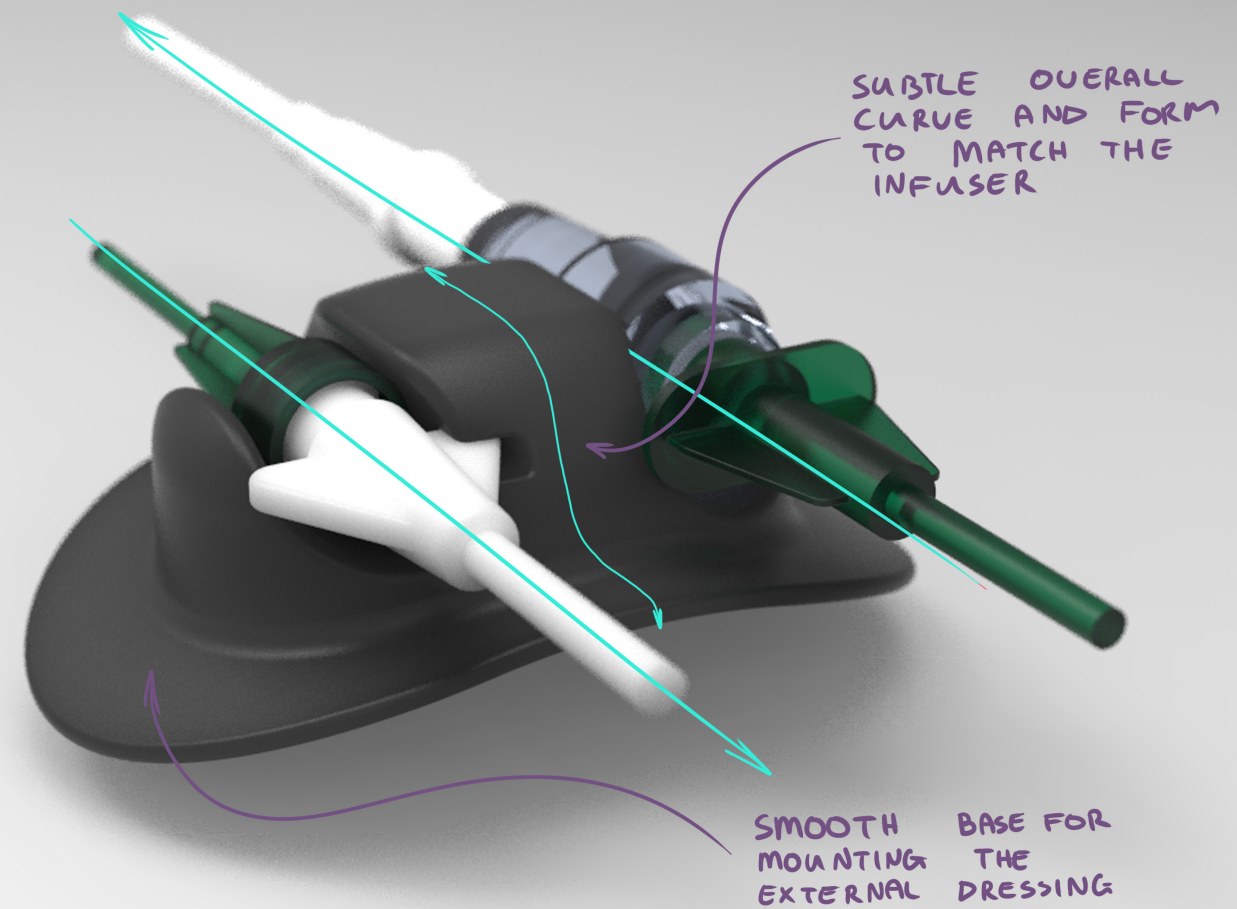


Figure 143. I then further refined the most successful IV clip design. This system used a subtle curve throughout the form of the clip to create a clip that more closely resembled the form of the infuser. The use of a slot for the PICC line, although less minimal, did allow for the orientation of the clip to be clearer. In addition, I felt that this would have made the clip more intuitive to use.

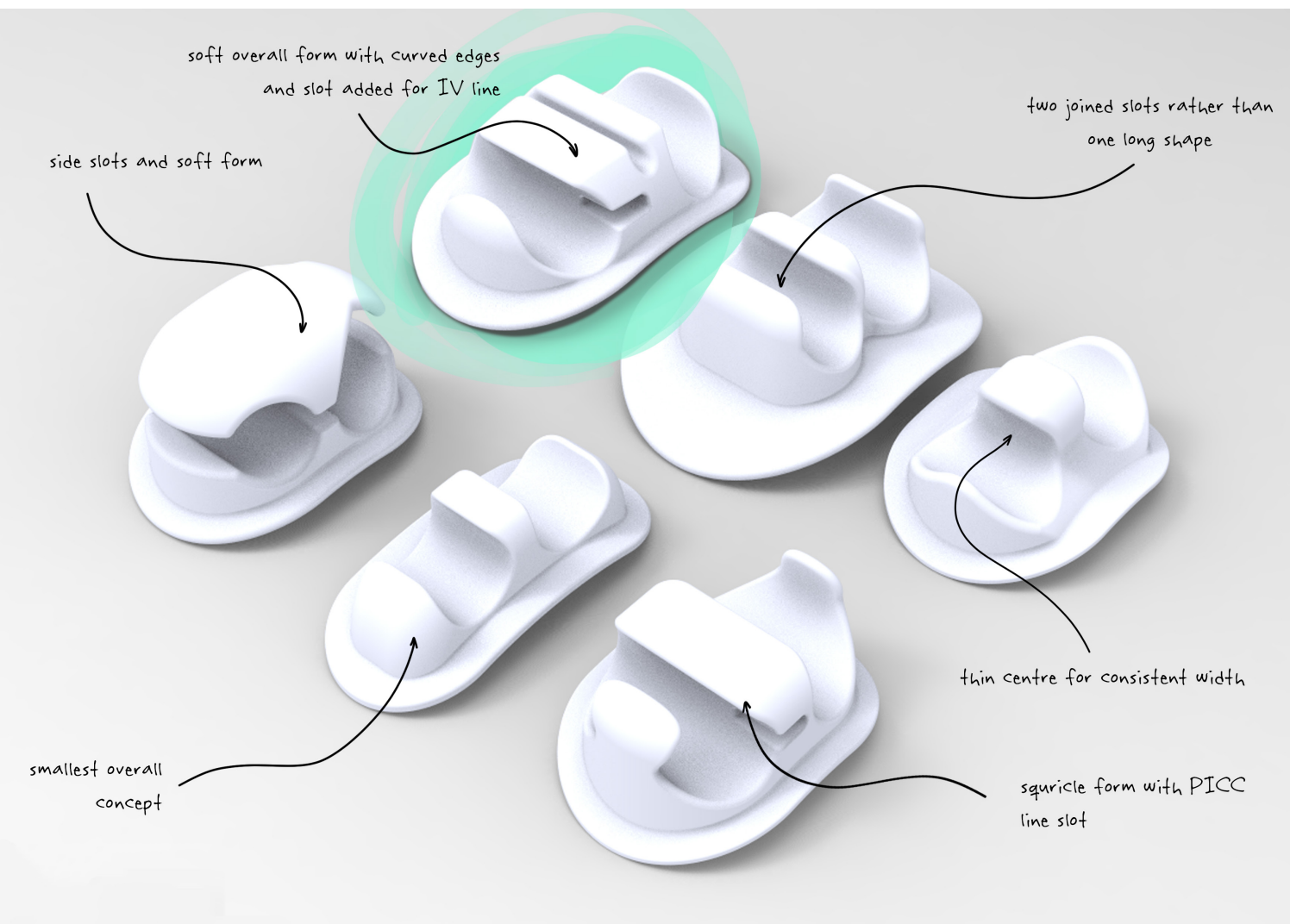


Figure 144. To finalise the IV clip, I compared all the IV joint clip designs. The softer form with vertical slots (highlighted) was aesthetically and functionally the most successful concept.

Further exploration around materials used for medical dressings and skin-safe adhesives identified that 3M produced a double-sided adhesive material that could be easily removed from both the skin and the IV clip without damaging either. This replaceable adhesive meant that it was possible to remove the flange and have an adhesive applied directly to the clip base.

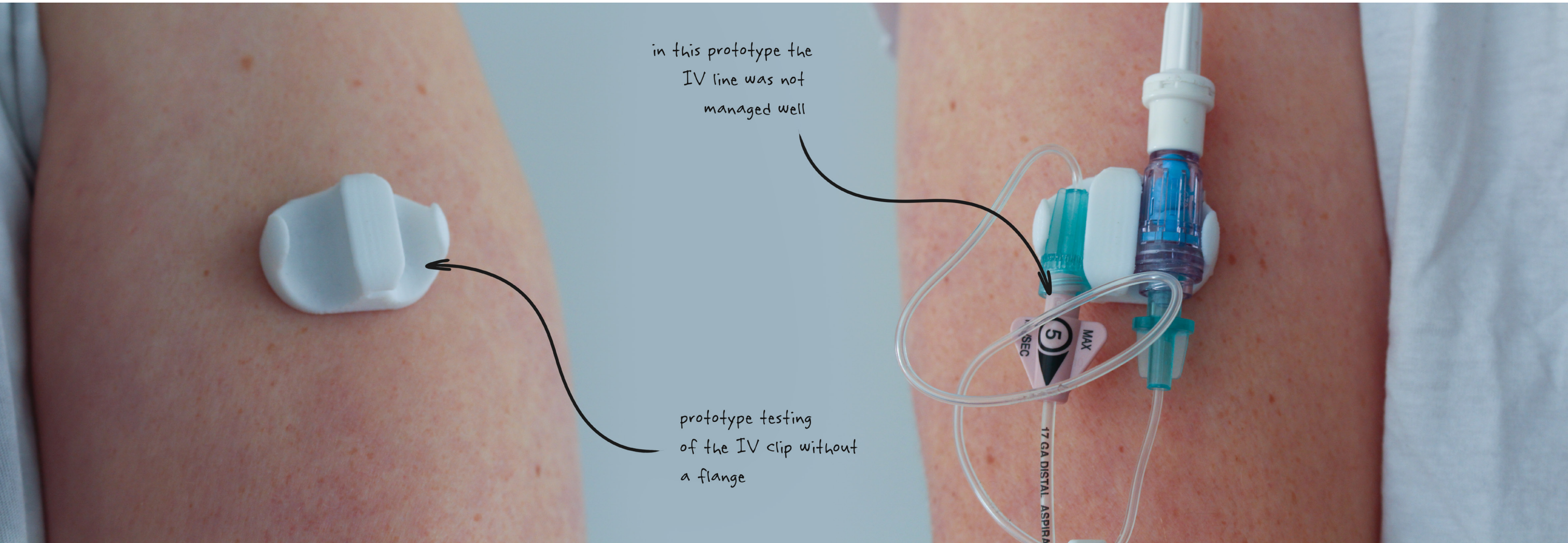


Figure 145. Prototyping testing with the 3M silicone securement system.

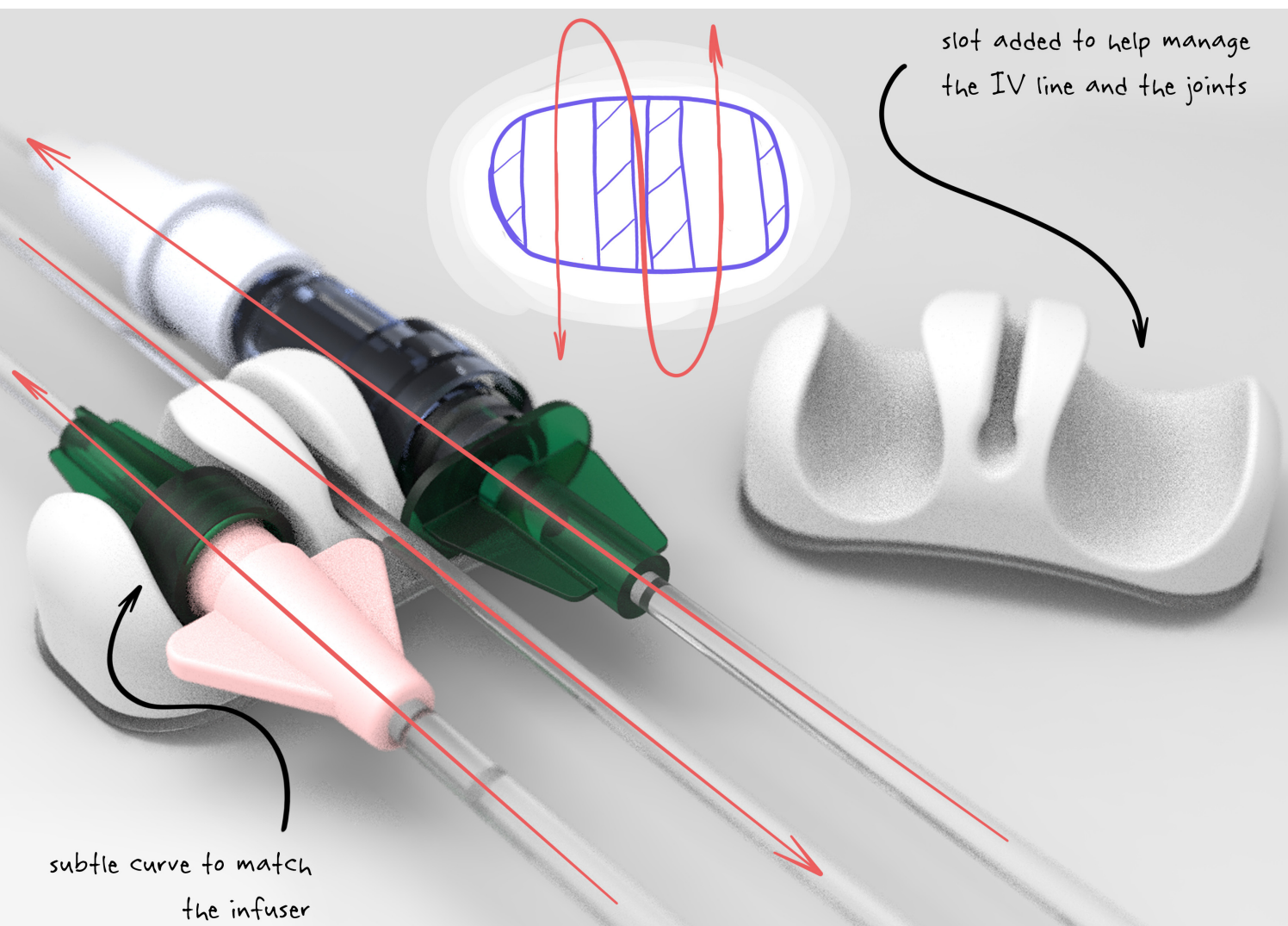


Figure 146. For the final IV clip, the size of the dressing mounting base was reduced as when using the 3M silicone securement system, the flange and larger size were not needed for a secure fit. Finally, although this system improved the risk of kinks in the IV line, attaching the IV line directly to the clip itself could be reduced further. Therefore, an IV-line slot was added to the top of the device. The slots used for the IV joints had a slight taper which allowed for a secure fit on the joints.

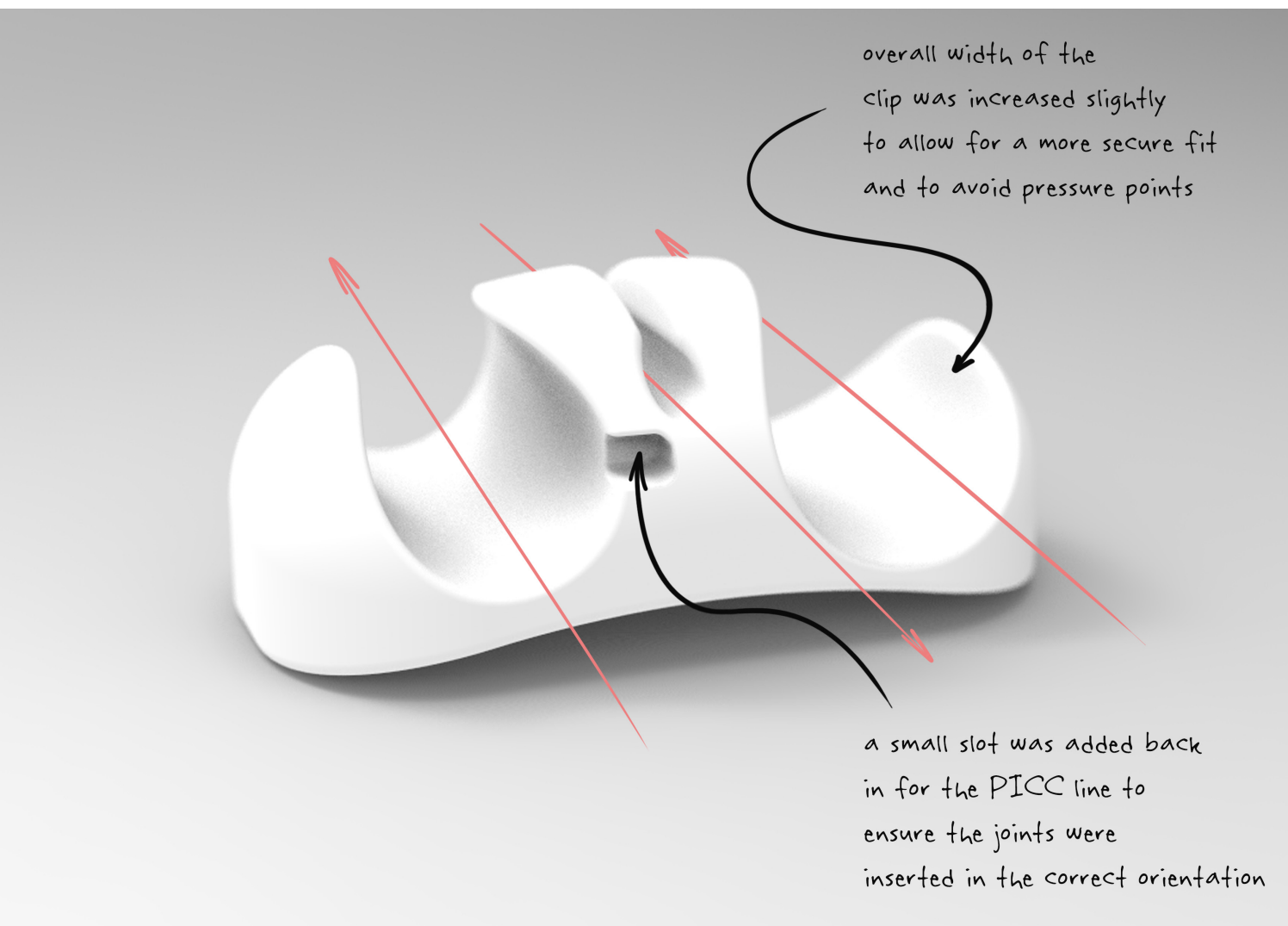


Figure 147. The finalised IV clip (CAD model).

System Extras - Further Refinement

Alongside the three main elements that made up the OPIVA system (the IV line dressings, the Baxter infuser, and the infuser storage bag), several other parts made up the system. Each of these had functional issues raised by participants. However, I decided to focus less on these elements as the highlighted issues were not as significant as those with other parts of the system. For example, although there were known issues caused by PICC line migration, none of the participants involved in this research experienced PICC line migration (as described by Hughes, 2014). As a comparison, the tape used to keep the IV line in place was a key issue highlighted by all participants. Although I wanted to address these other elements, they were not given the same degree of consideration or development as the other elements, primarily due to the time limitations of this research.

The PICC Line

As discussed earlier, one of the critical issues associated with PICC lines was PICC line migration. Migration is a process in which a PICC line moves out of a patient's body. PICC line migration can lead to infection if the PICC line is moved back into the body, or if the PICC line is removed far enough, the PICC line may need to be replaced as it will no longer function as intended and can damage the patients' veins (Hughes, 2014). For the most part, this was only an issue during dressing changes as the nurses who remove the dressings could accidentally cause PICC line migration (Berkett & Walford, 2013; Hughes, 2014). In addition, PICC line migration can occur if the patient were to pull on the PICC line. However, this was not common in the OPIVA service (Personal Communication OPIVA Nurse Expert Interview, November 30, 2020).

One product to solve PICC line migration was Interrad Medical's Securacath. Securacath was a device that used subdermal hooks to lock the PICC line in the patient's skin. This device removed the risk of PICC line migration as the PICC line could not move during treatment (Hughes, 2014; Culverwell et al., 2020). Although this provided many benefits for patients, Securacath could be painful upon removal (Personal Communication OPIVA Nurse Expert Critique, March 17, 2021).

At the time of writing, the Waitemata DHB did not use a system like Securacath, and as a result, nurses had to check the PICC line manually using a measuring tape to check for any migration. To help avoid this, I explored the use of a colour-coded PICC line. This way, only a quick visual check would be needed.

In addition, some participants expressed discomfort over the rigid plastic connector at the end of the PICC line. Although this could be resolved using a softer plastic or rubber cover, the IV clip could also address this issue by providing a secure place to hold the IV line connectors.

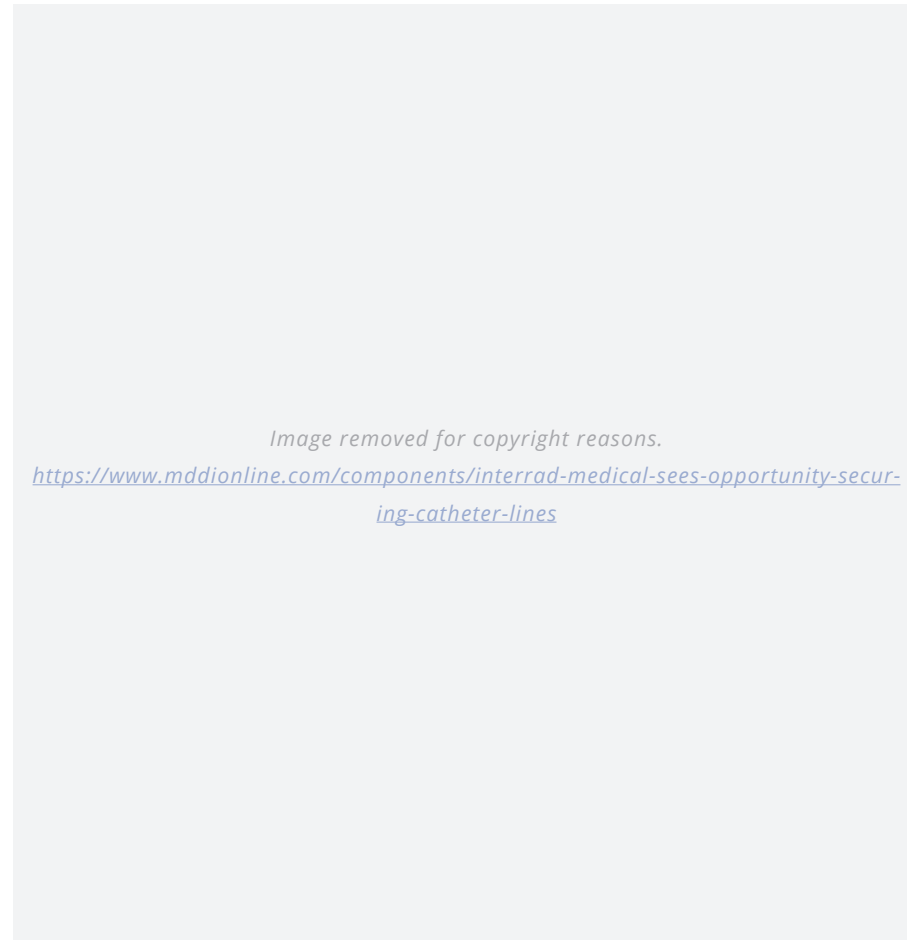


Figure 148. Hartford, (2015). Illustration of the Securacath system.

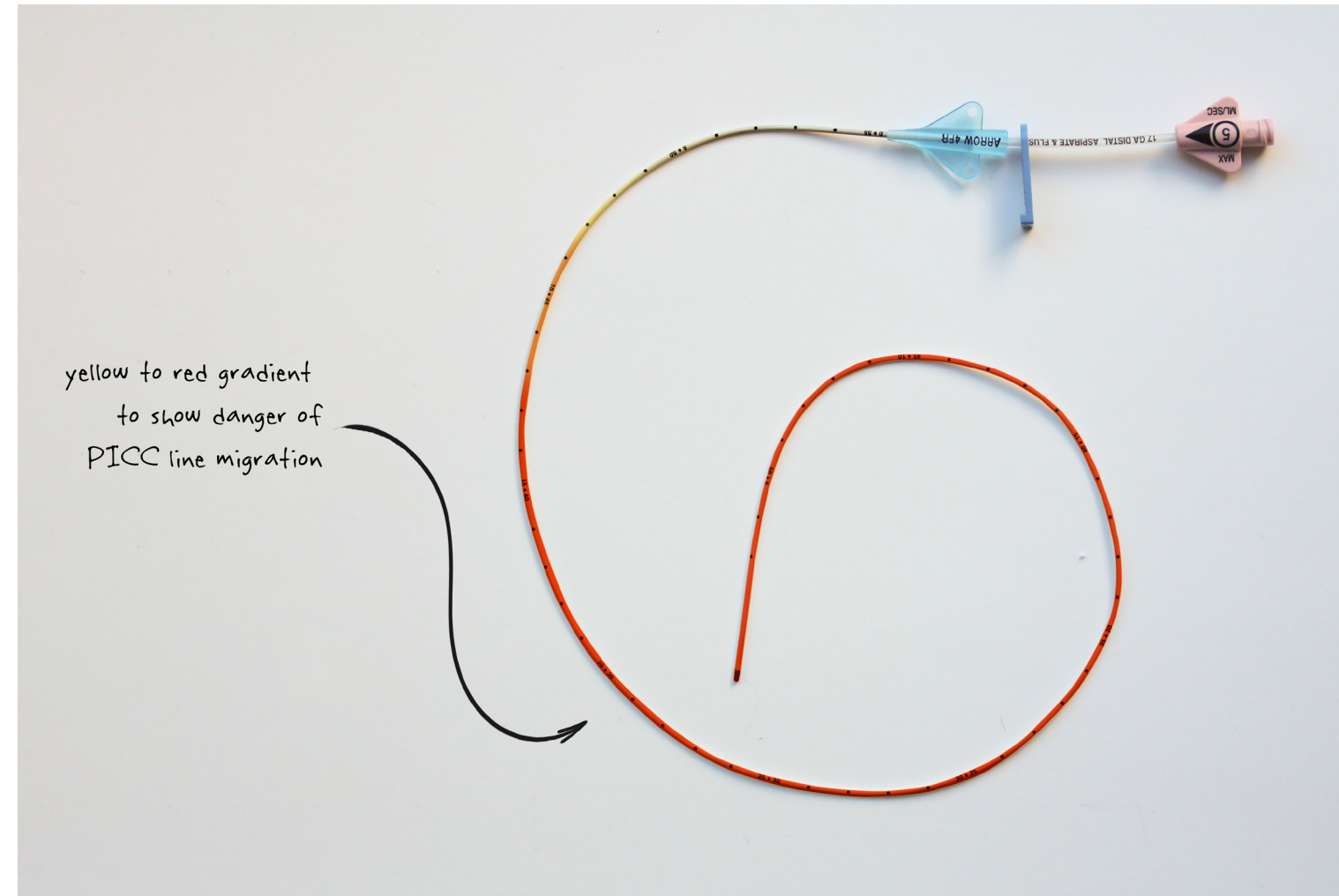
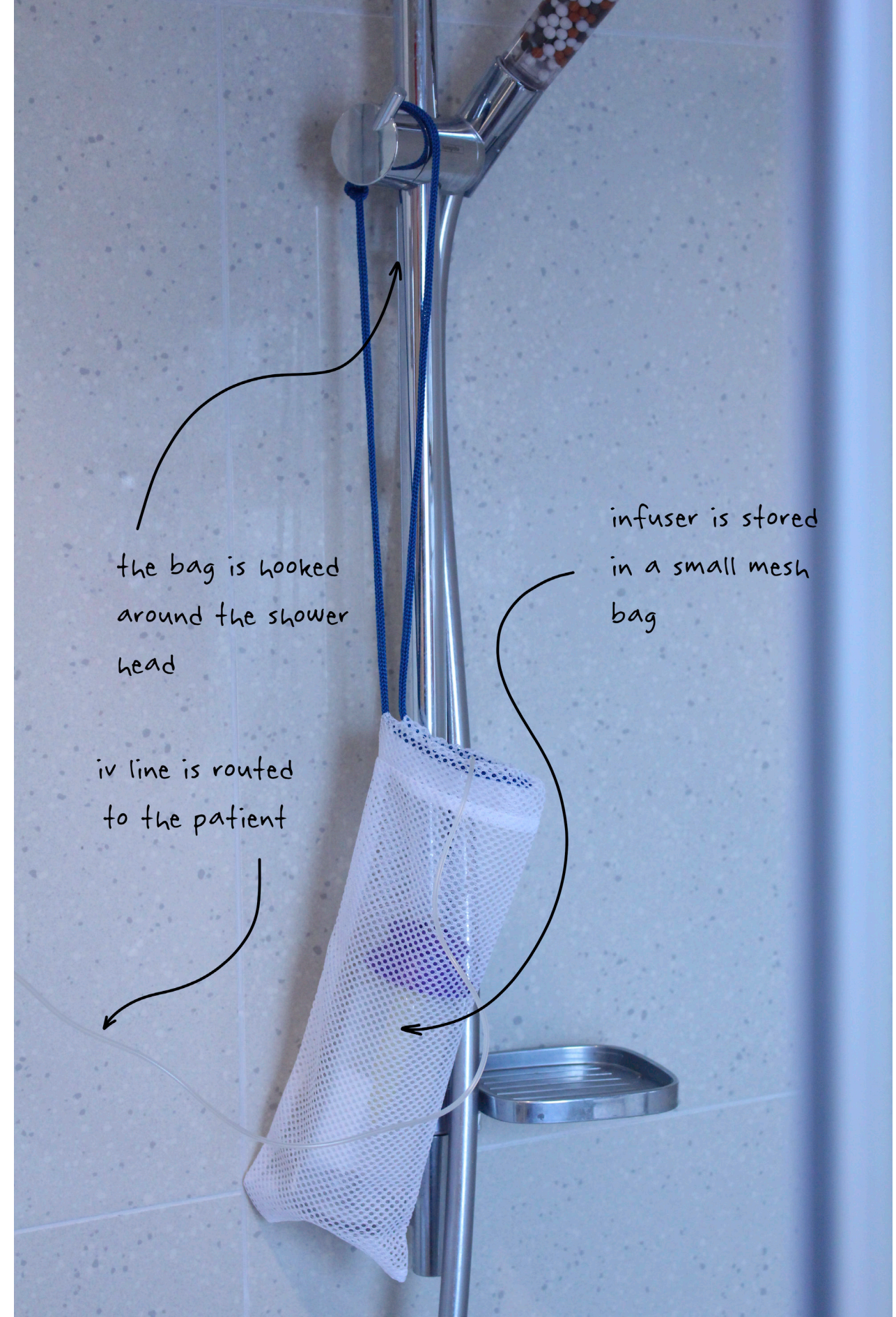


Figure 149. The PICC line was coloured from the existing white colour through to yellow and then red. With yellow showing a warning and red showing a danger point. These were chosen based on prior knowledge of colour meanings and warnings (Pravossoudovitch et al., 2014).

Shower Storage Solution

Baxter provided a small mesh drawstring bag and the waist storage bag at the start of a patient's treatment. The intention of this bag was to be hooked around a showerhead during use. As a result, the required placement of the bag was limiting for some participants. Two participants noted that they often placed the infuser in less secure locations in the shower as they used the shower in an atypical orientation. By placing the infuser on an unstable surface (and not using the provided bag), they were at risk of dropping and breaking the infuser. To work around this issue, I wanted to explore a more flexible shower storage system. This shower storage system needed to be easily usable in different placements in the shower to suit the user's preference.

Figure 150. The existing shower storage solution.



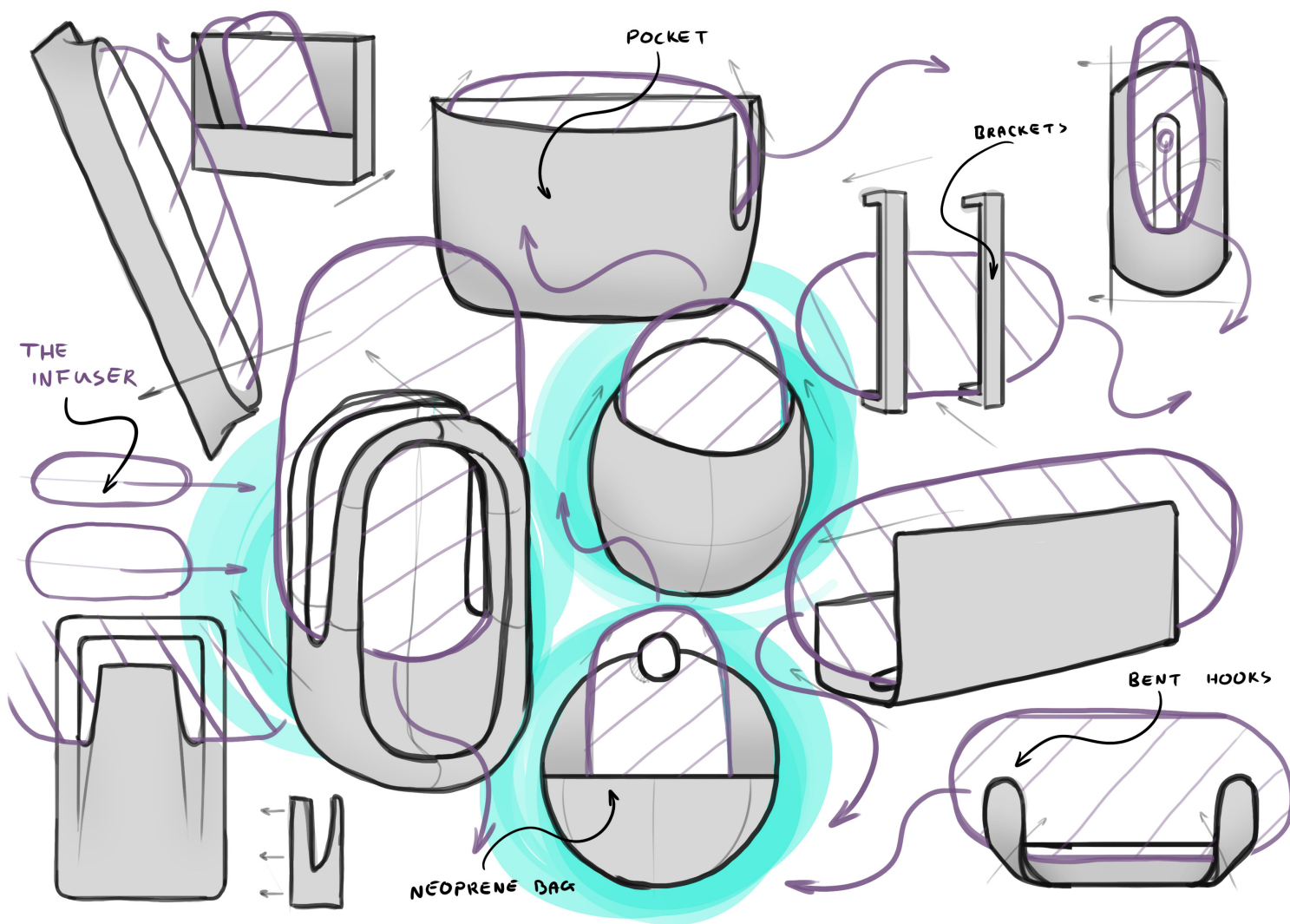


Figure 151. Exploration sketches of shower storage systems. I wanted to explore cradles, which could hold the infuser and storage bags with a more elegant aesthetic to match the rest of the system. The most successful three designs were highlighted (purple) (based on pleasing aesthetics and assumed functions).

All the shower storage solutions needed to mount securely on a surface in the shower. This secure mount aimed to avoid any damage to the infuser from accidentally dropping of the infuser while remaining flexible enough to be placed anywhere in the shower. Each design featured a simple adhesive patch to allow for secure mounting on glass or tiled surfaces. An adhesive material was chosen over a suction hook to ensure that the hook could not come loose accidentally during use, as may be a risk with a suction cup. Suction cups of 85mm can hold up to 9 kgs, whereas 3M's "high strength double-sided tape" can hold the same weight at a fifth the size (3M, 2021; Adams, 2021). To allow for a smaller overall size, participants would need to sacrifice some flexibility and mount the storage in one location throughout the duration of the treatment.



Figure 152. Prototype of the first concept being tested in the shower.

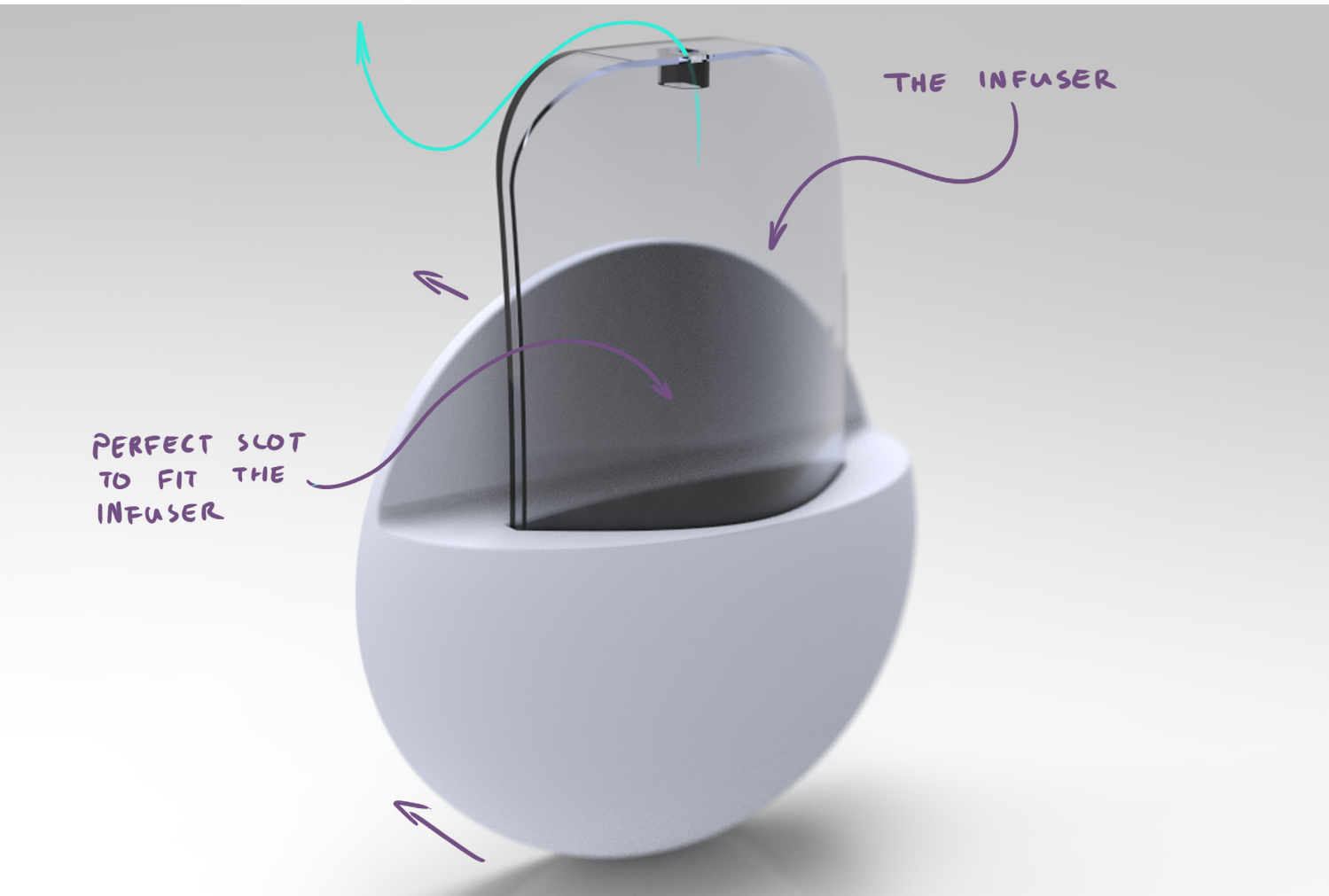


Figure 153. The first CAD concept for the shower storage solution featured a simple circular cradle formed exactly around the infuser for the most secure fit.



Figure 154. Prototype of the second concept being tested in the shower.

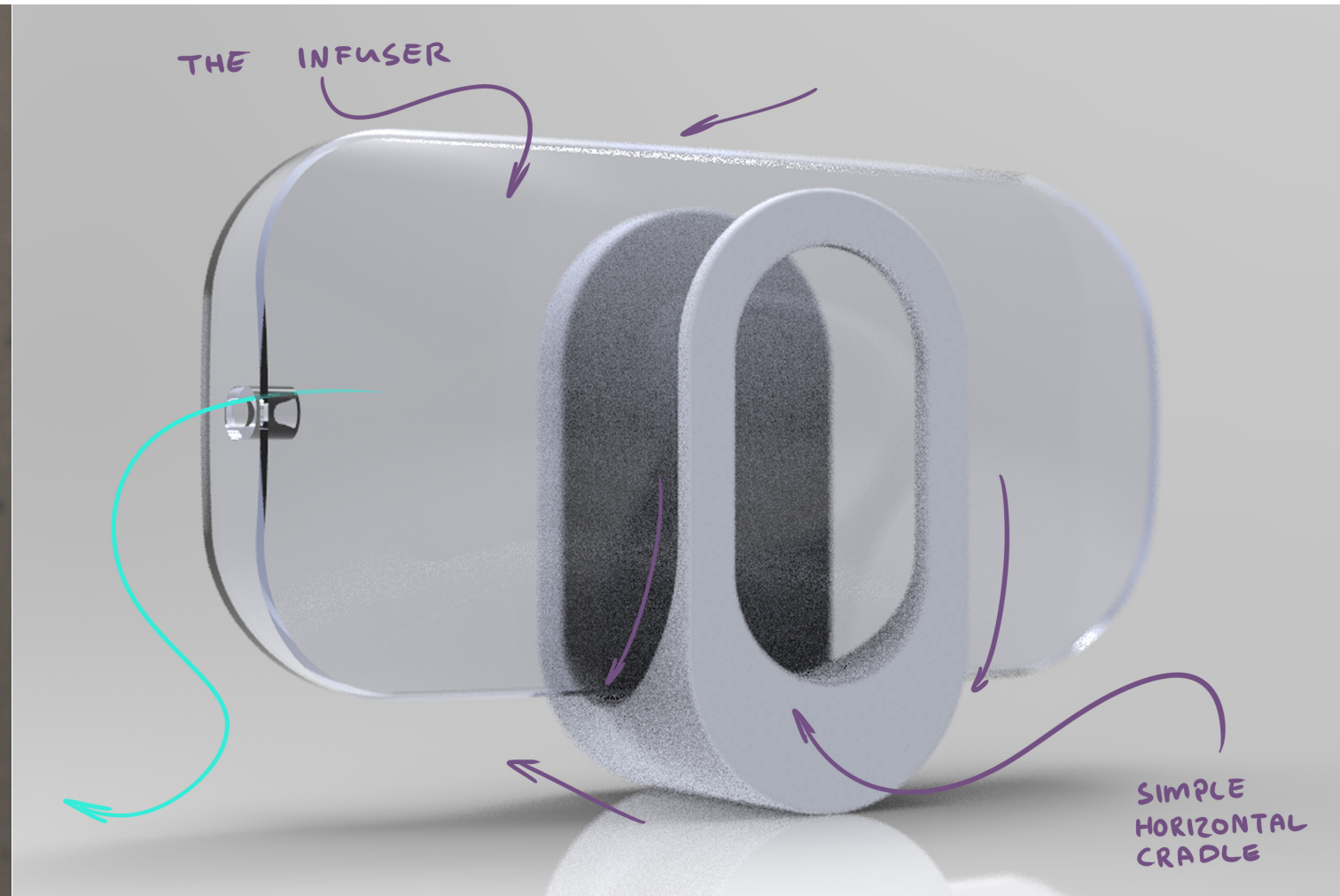


Figure 155. The second infuser storage concept used a horizontal rather than a vertical orientation for the infuser. This cradle form caused more instability in the infuser, risking dropping the infuser at the cost of decreasing the cradle's overall size.



Figure 156. Prototype of the shower hook and infuser storage pouch for use with the hook.

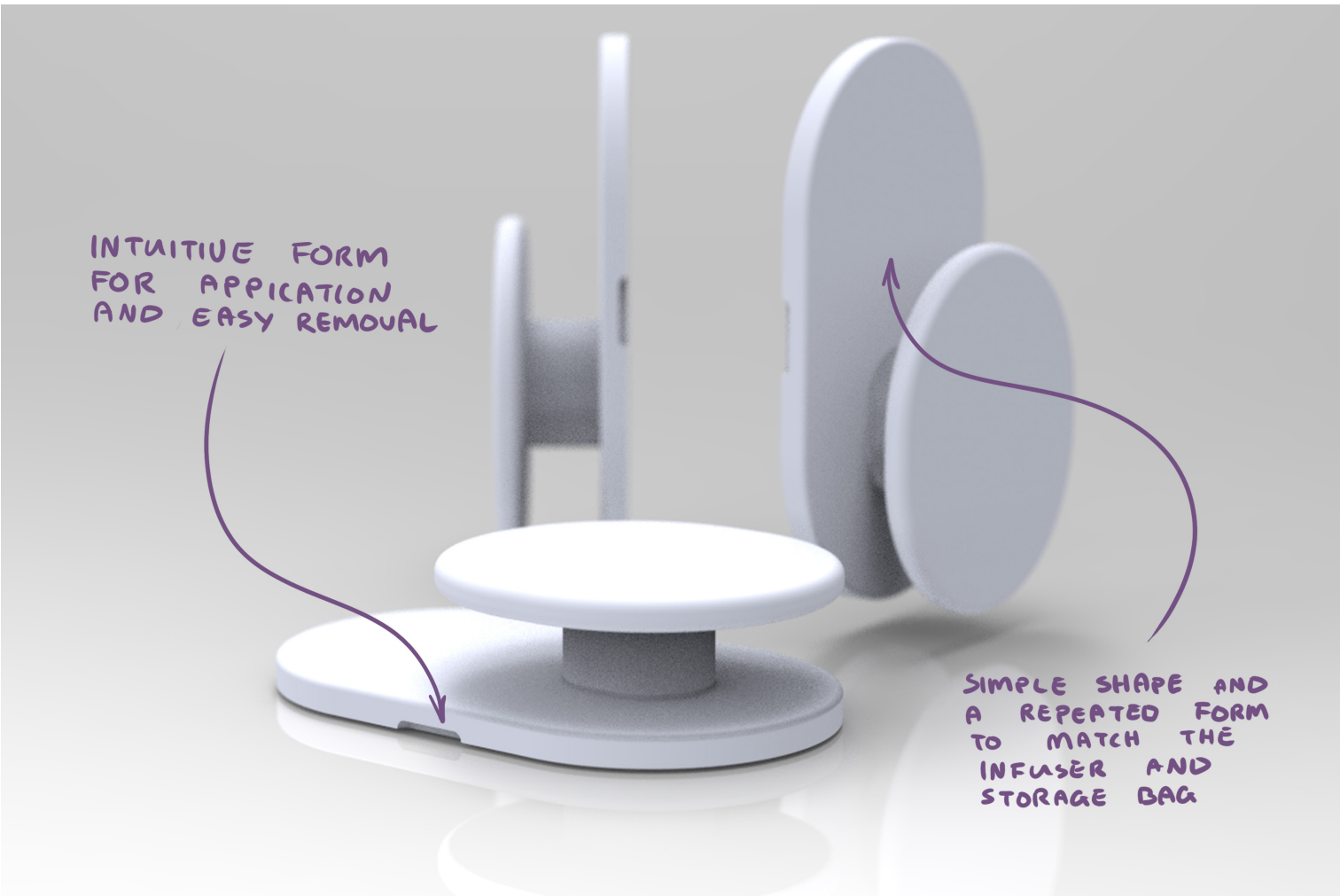


Figure 157. The third concept for the shower storage solution featured a hook combined with a neoprene bag to hold the infuser. Neoprene was chosen so that the infuser could be kept insulated in the shower and would maintain the system's aesthetic.



Figure 158. A second bag prototype was developed to hold the infuser more securely by wrapping around more of the infuser and using a vertical orientation.

The Positive Pressure Valve

An issue raised by the OPIVA nurses was that all the threaded parts of the OPIVA system used threads that rotate in the same direction. For most parts of the system, this was not an issue. However, patients were required to unthread the flow restrictor from the positive pressure valve every day. If patients were not careful, they might also unthread the valve from the IV extension line. Unthreading the valve would open the system creating a significant risk of infection (González et al., 2014). Although this was not a common issue, the OPIVA nurses reported that patients had done this in the past (Personal Communication OPIVA Nurse Expert Interview, November 30, 2020). I wanted to explore a solution to this issue by giving each end of the positive pressure valve an opposite thread direction, and by extension, changing the thread direction on the infuser flow restrictor. Participants did not express any issues with this element of the system, so no other changes were made to this part of the system.

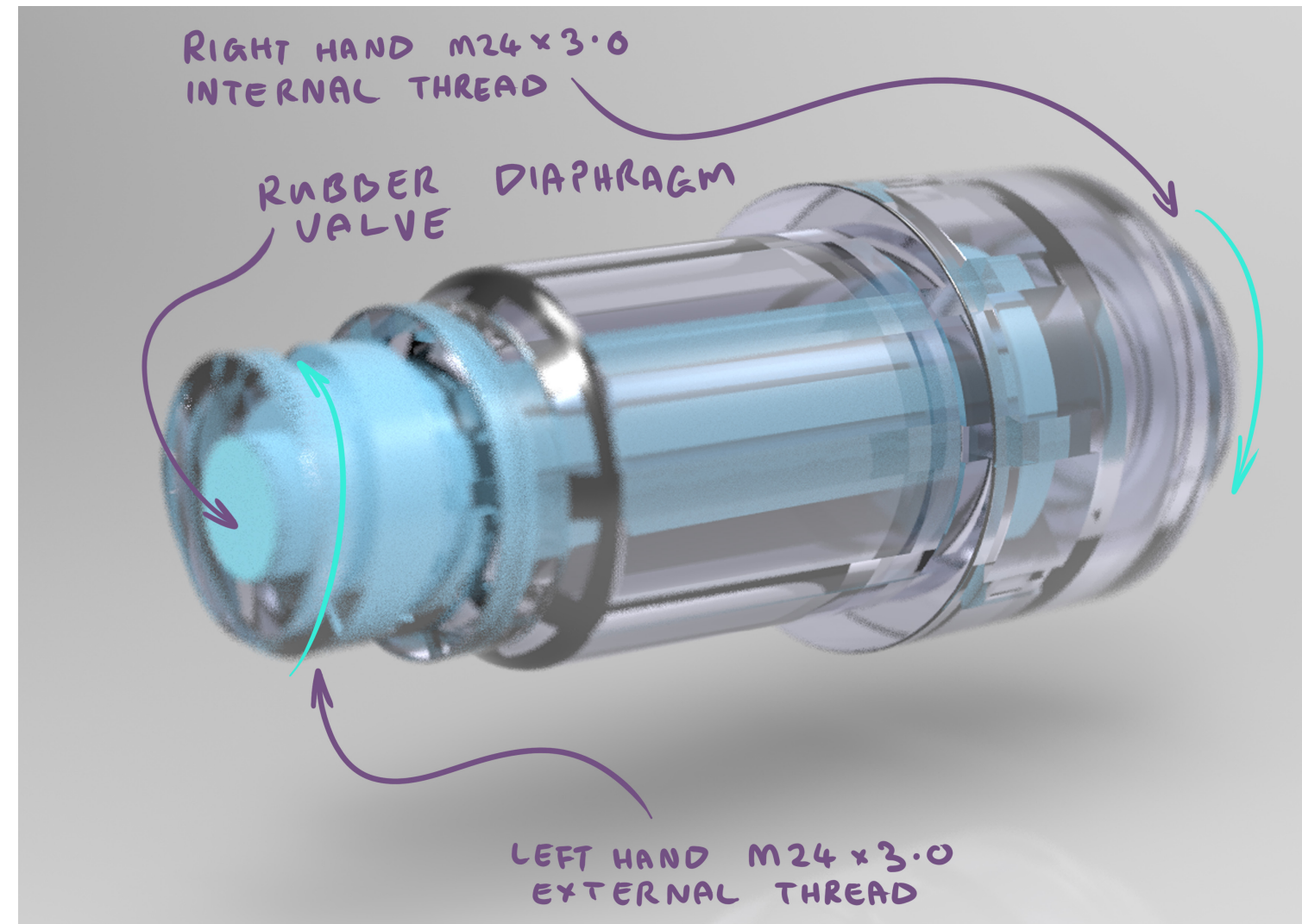


Figure 159. CAD modelling exploration of the positive pressure valve. The thread which would attach to the flow restrictor was given an opposite thread direction. Some users may expect this to be a right-hand thread, so the infuser flow restrictor will have an icon to show the thread direction so patients could avoid possible misuse of these two elements.

PICC Line Protection Sleeve

The final element of the system I wanted to explore was the sleeve used to protect and cover the PICC line and dressing. In the existing system, a loose tubular bandage was cut to length for the patient. Unfortunately, this tended to roll down on the patient, causing discomfort and risking deep vein thrombosis (DVT) and pulmonary embolism (Colyar, 2020). I explored how a simple, breathable spandex sleeve could be used to cover the dressings to address this issue. By using a simple black colour, this fitted with the overall minimal aesthetic of my system. Through discussion with patient participants, this sleeve simply needed to avoid rolling down during everyday use and cover the PICC line and dressing without applying pressure to the system (which could lead to DVT (Colyar, 2020; Jowett & Robinson, 1995)).

I prototyped a black spandex sleeve with elastic at the top and bottom to provide a loose but secure fit. A small gap was left in the elastic to allow the IV line to be routed out of the sleeve without creating a pressure point on the patient's skin. Although these were more expensive to produce than the tubular bandage, they provide less risk of blood clots as the sleeve did not roll down during everyday use (during user testing) and met the patient needs more than the bandage.

The tubular bandage used in the existing service was not specifically designed for the OPIVA services. Thus, a new specialised product would create additional costs for the service, making the adoption of this element unlikely. Regardless, the existing tubular bandage caused issues for some patients in the service; therefore, I wanted to highlight these issues in my final system.

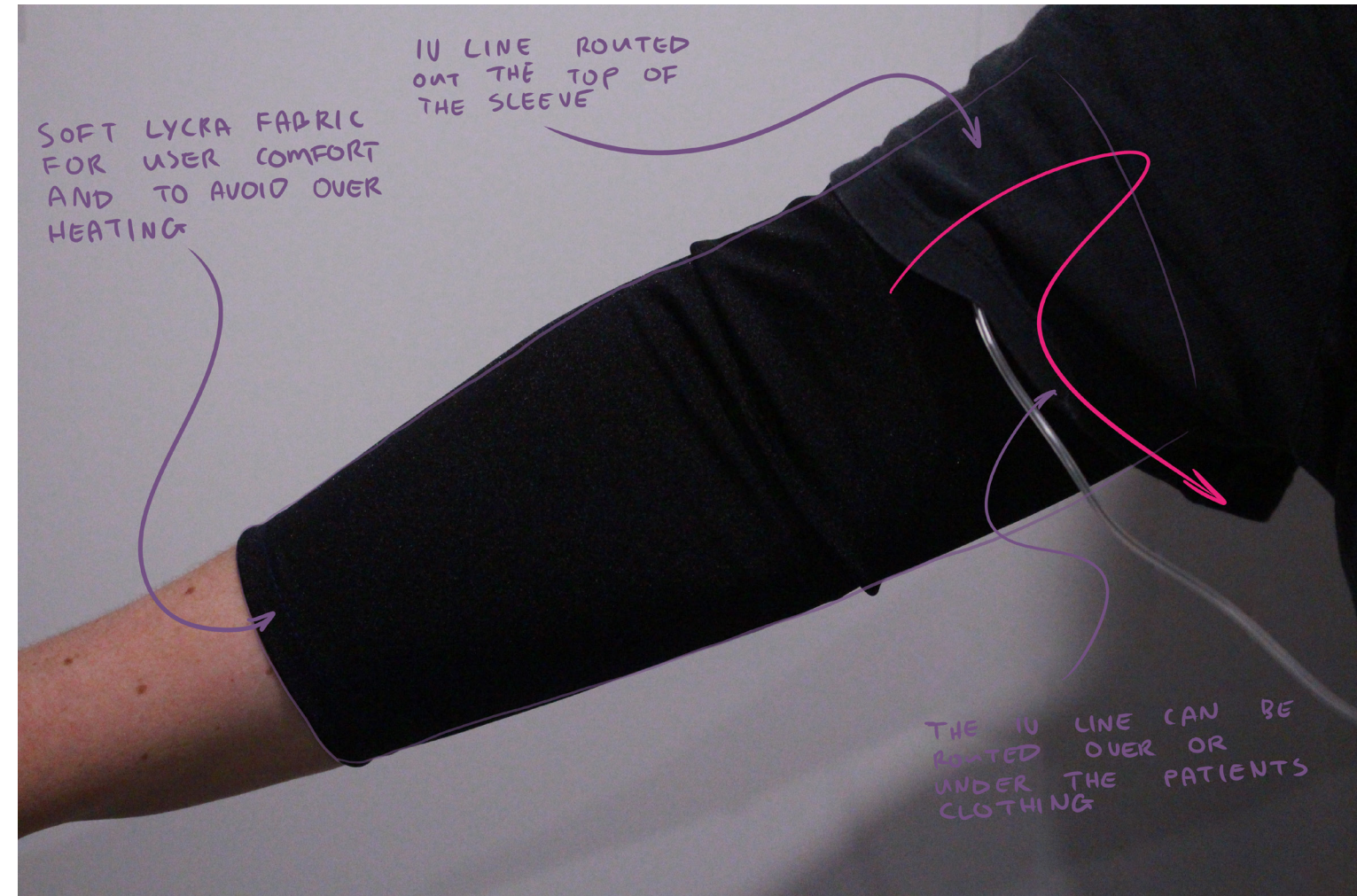


Figure 160. The prototype of the IV protection sleeve. The sleeve would be produced in different sizes depending on the user.

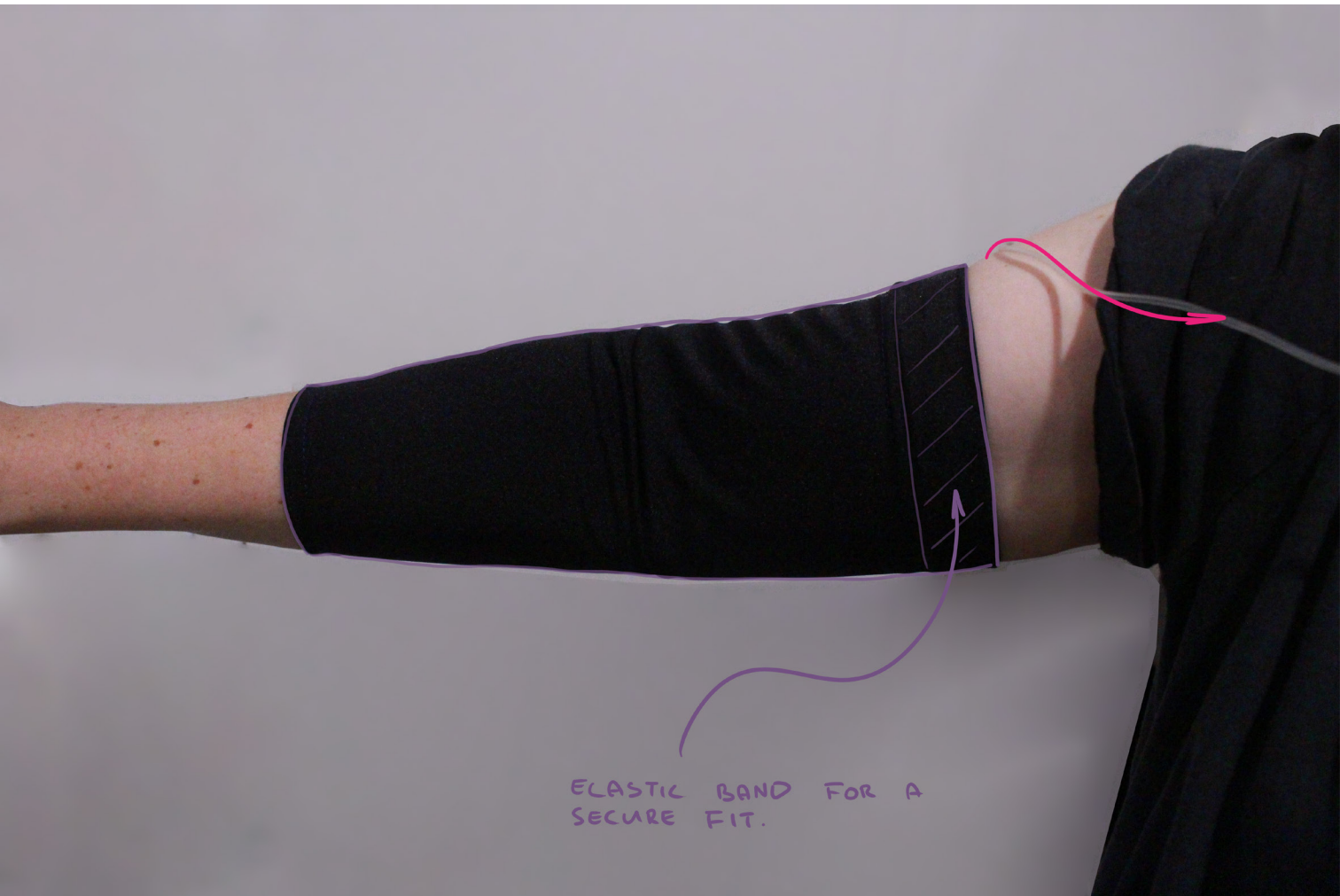


Figure 161. Although the IV clips could be a one size fits all design, the sleeve would need to fit more accurately for each user to ensure that the risk of DVT was minimised.

Second Expert Critique

Expert User, Previous Patient and OPIVA Nurse

The patient users both had negative experiences with the tube bandages used by the OPIVA service. Therefore, they reacted positively to the idea of a sleeve made of a fabric that would not be prone to rolling down the arm during use and would be more comfortable for use. The OPIVA nurse was concerned about the cost of this, similarly to the IV clip system, citing the low cost of the tube bandage and the choice to use a light fitting fabric to avoid DVT (Colyar, 2020; Jowett & Robinson, 1995). As with the IV clip system, I still wanted to explore the sleeve as patient participants cited this as a direct cause of frustration in the service. The positive pressure valve, PICC line and adhesive based shower storage system were all positively received. The participants preferred the shower hook and bag shower storage solution over the cradle-based solutions. These could function with the existing shower bag provided by Baxter and would be relatively cheap to produce.

IV Line Management – Finalising

Through prototyping, I found that the shower hook design could be reduced in size while still maintaining a secure fit on the infuser shower bag. Along with this, the bracket-style shower storage solutions were cumbersome and would be expensive to manufacture. Therefore, I decided the shower hook and neoprene storage bag was the most appropriate solution for the shower storage.

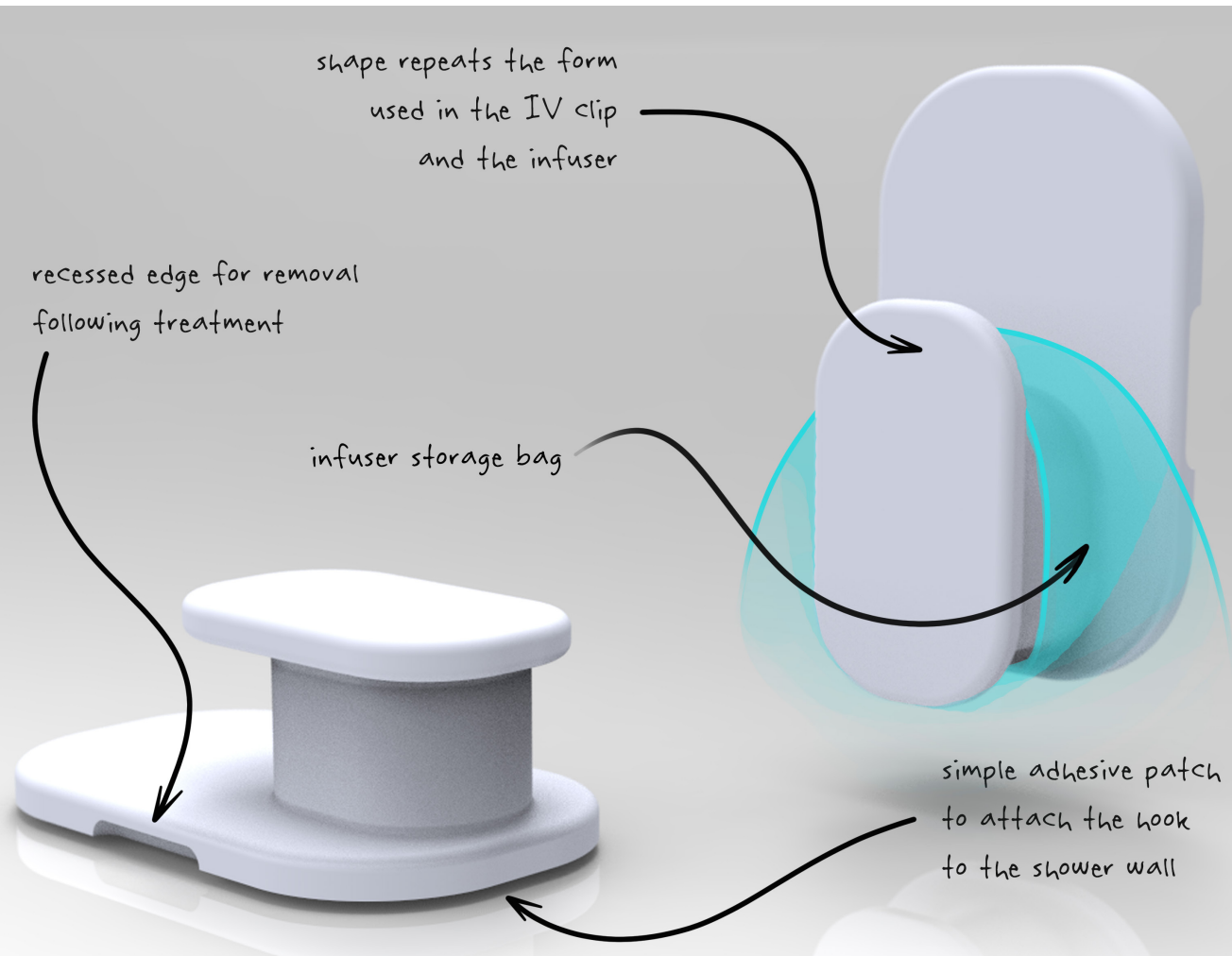


Figure 162. The finalised shower storage hook CAD model.



Figure 163. The resized shower clip with the neoprene storage bag in the shower.

06. Research Outcomes

Baxter

↓ INSERT INFUSER HERE ↓





PRESSURE
INJECTABLE



10 ml/h
CE







IV INFUSER

EXTENSION STRAP

SHOWER HOOK

IV LINE CLIP



PICC LINE,
IV EXTENSION,
POSITIVE AND
PRESSURE VALVE

ARM SLEEVE

STORAGE BAG

SHOWER BAG

07. Discussion

The OPIVA research opportunity was initially suggested to the supervision team by a prior patient of the OPIVA service. From their experience, it had initially appeared the project would explore a simple IV-line management system to avoid the surgical tape used in the existing system. However, as I began to understand the literature surrounding the context of outpatient intravenous antibiotic services and started to conduct primary research with patients and clinicians of the Waitemātā DHB's OPIVA service, it became clearer the breadth and extent of challenges patients faced when using these systems. By using a human-centred design approach, I was able to better understand the experiences of OPIVA patients more intimately. I was able to gain some insight and reflect on the struggles that came with learning to manage a medical treatment at home and the feelings that patients experienced during such a stressful and life-threatening period of their lives. Throughout the research, it was clear that patients cared about their experiences and wanted to see improvements made to the services they received treatment from. This research suggests that the inclusion of patients in the design of medical devices through HCD can benefit patients experiences with and the usability of medical devices.

At the initiation of this research, I had anticipated that manufacturing and technical issues would be the most significant challenges I would face in the research. In the past, I have found that my ideas sometimes were not feasible within the limits of manufacturing technologies. However, in this project, the biggest challenge I faced was managing the complexities of the research. It was clear that there was room for changes within the OPIVA service from a service design perspective that might address some of the issues highlighted by participants. However, my focus was on improving the products that made up the OPIVA treatment system. I soon became aware, however, that even these elements could be significantly improved. As a designer, I wanted to present design solutions that were feasible and received positively by

clinical stakeholders and managed the complexities of the system. It was also important that clinical stakeholders saw the potential for a new system to improve treatment experiences. Consequently, it is hoped that in any future development in this area that the challenges of product uptake "...may be minimised if design interventions that address clinical problems take the form of a redesign of an existing product, rather than a new type of device, and importantly match the cost of the existing product." (West, 2020).

07.1. Design Research Outcomes

New Knowledge

I have had many medical experiences throughout my life, both positive and negative. However, working with OPIVA patients and clinical staff gave me a new perspective on not only the research subject but also my own life experiences. I was able to begin to empathise and understand the experiences that patients had in the OPIVA service. The OPIVA service provides patients with lifesaving treatment while allowing patients to recover from serious illnesses at home. Although there were many positives associated with the treatment, patients were required to learn to manage their own treatment at home, and this often led to other problems (and unforeseen consequences). While mistakes were not common, they still occurred, and many patients experienced anxiety and stress throughout their treatment. I learnt that by involving patients in the design process of medical devices, designers could better understand and meet the needs of patients (specifically relating to the OPIVA treatment system). By better understanding the needs of patients, it may be possible to improve the health outcomes for patients, especially in treatments where patients are the primary user.

Martin et al. (2008) discussed the methods that were used to design and develop medical devices. They highlighted the importance of designing medical products without requiring modification or misuse for effective use. This concept of effective medical devices not requiring modification or misuse was highlighted clearly in the unexpected ways that patients managed the OPIVA service in their home environment. If medical device development does not include the main users of a product in the design process, the product

outcomes are unlikely to completely meet their needs (Money et al., 2011). For many patients in the OPIVA service, they were both the care provider and the care receiver. Garmer et al. (2004) presented similar ideas, highlighting that accidents and adverse events could be reduced if the usability of medical devices were improved. I hope that by presenting a design process that used HCD as a basis for empathising with patients and including their experiences more directly in the development process, I will contribute to a precedent for future research to explore more possibilities for human-centred research to improve health outcomes for patients receiving treatment from similar or related systems.

Before this research, there were few studies that considered the experiences of patients in OPIVA services. This was the first body of research that presented an alternative to the existing system that attempted to improve the patient experience (Dodd, 2007; Kumari et al., 2018; Upton et al., 2004; Zahnd et al., 1999). Although existing research had considered patient's experiences with OPIVA services, PICC lines and with elastomeric infusers, no other body of research had highlighted the way that patients interacted with OPIVA treatment systems as a cohesive product system, from the PICC line to the infuser storage bag (Alpenberg et al., 2015; Dodd, 2007; Nicholson & Davies, 2013). Within the context of the OPIVA service, PICC lines, elastomeric infusers, waist bags, surgical tape, IV lines, and sterile dressings do not exist without each other. I wanted to ensure my research reflected the holistic nature of the service.

Appreciation for the Nurses

Throughout the research, a common theme shared by patient participants was an appreciation for the communication and support that the OPIVA nurses and DNs provided throughout their treatment within the OPIVA service at Waitemata DHB. Although this communication was not an area of focus in this research, I felt it was important to highlight as the OPIVA nurses rarely get feedback from the patients once they have been discharged from the service (Personal Communication OPIVA Nurse Expert Interview, November 30, 2020). The involvement of the nurses in the service was both a positive and a negative for the service. Through this research, I heard that the OPIVA nurses were directly involved with patients throughout their treatment, from setting up the OPIVA system to answering questions once patients were discharged. There was a risk however, with this type of engagement, that if the service continued to grow that the nurses could become overloaded, and they may not be able to provide the treatment as effectively. By exploring the usability issues of the OPIVA treatment system, I hoped to explore ways that HCD could be used to improve the OPIVA system. By improving the usability of the system, accidents and adverse events could be reduced, alleviating the responsibility of the OPIVA nurses to manage the ramifications of these events (Martin et al., 2008; Garmer et al., 2004).

Intended Use, Actual Use and Misuse

The existing literature focused on how to address and avoid potential misuse through design strategies (Almakky, 2017; Blackler et al., 2003; Lin et al., 2001; Wiklund, 2005). Through my research, I was able to re-contextualise ideas around misuse by considering the ways that patients used the devices of the OPIVA system. Patients spent between two and twelve weeks at home managing the OPIVA device system with daily or weekly visits from the DNs (depending on their ability to make daily infuser changes). This time alone meant participants had to learn to manage it in their home environment (sometimes resulting in the misuse of the OPIVA system). These unintended uses could lead to harmful misuse (e.g., unthreading the positive pressure valve). The design of products in a medical setting should aim to minimise the harm that could be caused by misuse (Almakky, 2017; Blackler et al., 2003; Lin et al., 2001; Wiklund, 2005). However, I found there were many examples of patients who used elements of the system differently from the guidelines outlined by the Waitemata DHB. These changes to use were often non-harmful. Wrapson et al. (2017) highlighted similar findings in the context of long term tracheostomy users. They found that tracheostomy users would often find their own solutions to problems, such as using neck chains or old bra elastic to replace the tape provided to hold the tracheostomy tube in place. This tape could wear out and users were often expected to replace this at their own cost. As a result, patients had to be resourceful to meet their needs (Wrapson et al., 2017). These examples of use differed to the patient's at home care guidelines (Capital & Coast District Health Board, 2015). In this research I explored how the 'misuses' of the OPIVA treatment system could be reframed to benefit the patient and improve the inclusivity of the service. Simple elements such as adding an extension to the waist bag allowed the bag to be used comfortably in either a waist or across body orientation, and even a simple adhesive hook allowed for the infuser to be placed on different parts of the shower at the

patient's preference. Rather than avoiding potential unintended use of the system, I aimed to accommodate different uses of the products to make a system that was accommodating for a greater diversity of users' needs (e.g. those with limited mobility).

07.2. Recommendations and Limitations

What should be done in future?

Through action research, mixed-methods and HCD, I explored the OPIVA system of products in an attempt to improve their usability. I decided to use a research methodology that would allow my design process to prioritise the needs of the patient's while allowing for a flexible approach to data collection and evaluation (McNiff, 2013; McNiff, 2017). Action research lent itself well to this research as I was able to use the second research cycle to shift the focus of the research and refine my design brief and goals. As this research took place within a medical setting, using a mixed methods approach that could use both qualitative and quantitative data was important to the validity of the research outcome. Although quantitative data did not play as important a role in the research as I originally expected, it was still beneficial to have a research methodology that could consider this data effectively as it allowed me to consider data from existing quantitative research, such as ergonomics. Although participatory HCD had been the goal of this research, it was difficult to include the experiences of patients throughout the process due to the limited number of participants and the challenges of recruitment. There were challenges balancing the ethical elements of working with patients involved in life-saving treatment and the ways that the Waitematā DHB supported how research could be conducted. Balancing these areas meant that the research recruitment period lasted around three months. I was unable to recruit sufficient participants within the research timeframe to conduct co-design workshops (as I had originally hoped). As a result, only the expert user had any direct involvement with providing feedback throughout the entire design process. The involvement of this expert user added a high degree of user

participation to the design process. Through the three expert critique sessions, we were able to have many rich discussions, which helped me to not only empathise with their experiences but also to allow them to play a direct role in the design outcomes of the research. These sessions acted as both expert critiques and participatory design opportunities. Recruitment and participation challenges led to limited use of participatory design methods in the final research outcome.

Participation and Recruitment

The participation by clinical staff and former patients in this research proved to be one of the more difficult areas to navigate. During recruitment, several clinical staff at North Shore Hospital had expressed an interest in participating in the research. However, although DNs were contacted to invite participation, none expressed an interest in participating when formally invited. This limited the clinical perspectives in this research to only nurses and clinical staff working within the hospital setting. Nurses are often overworked and deal with high-stress levels, and it was likely that the DN's contacted did not have the time to participate in research beyond their already busy schedules (Jacobson et al., 2008; Rizzuto et al., 1994). In much of the existing literature that explored the implementation of design in healthcare, the recruitment of healthcare staff and lack of time and support for staff to engage with research was often found to be one of the key barriers to research occurring (Ramos et al., 2020; Shah & Robinson, 2007). Several patient participants highlighted the differences in care methods provided by the DNs, and it would have been beneficial to the research to have explored these. Along with this, the DNs were more directly involved with the OPIVA service in terms of day-to-day care than OPIVA nurses. Although the OPIVA nurses set up the patients with their first infuser, patients were managed at home with the support of the DNs. For future research working within the context of the OPIVA service, considering the experiences of the DNs (as well as hospital clinical staff and patients) would be important to include the perspectives of all users in the research outcomes.

From the start of the research process, I had one previous OPIVA patient who was willing to participate in the research (and initiated this project). However, the recruitment of other patients proved to be difficult on multiple levels- between navigating the ethics approval process and what was practically possible with OPIVA patients. Of the 31 previous patients invited to participate

in the research, four patients responded and agreed to be interviewed about their experiences. The research may have benefitted from more participants to increase the diversity of experiences contributing to the research. To achieve a greater range of participants, a more long-term study may have resulted in an increase in the number of participants.

As well as an increased research recruitment period, considering the experiences of patients outside the Waitematā DHB's OPIVA service could have improved the validity of design decisions made in this research. Within New Zealand, there were several other outpatient intravenous antibiotic services that functioned in a similar way to Waitematā DHB's OPIVA service. The Auckland District Health Board's OPIVA service, Counties Manukia Health's Outpatient Antimicrobial Therapy (OPAT) service were two examples within the Auckland region. Although the results may have been more generalised, they may have allowed for a more holistic patient perspective on the service. Unfortunately, within the scope and timeframe of this research, I was not able to work with other district health boards across New Zealand.

Along with a broader range of patient experiences, the perspectives of more hospital stakeholders would be a benefit for future research in this area. Several assumptions around the choice to use Baxter's infusers in the OPIVA service were made, and for future research to improve the service, the direct involvement of Baxter and the Waitematā DHB's management staff would be needed. Understanding the economic and manufacturing limitations of the existing OPIVA service may allow for a more refined and viable design outcome.

Barriers to Product Implementation

As a designer, I wanted my research to provide tangible benefits to those involved in the research. While the design outcomes may be significant improvements to the existing system, they may never be adopted or even considered by hospital management. Ramos et al. (2019) discussed the relationship between design-based practice and the barrier to implementation in healthcare. Ramos et al. (2019) interviewed facilitators involved in seven experienced based co-design (EBCD) projects and found that personal and organisational barriers were the main hindrances to the success of EBCD research. Piper et al. (2012) also identified that healthcare staff felt that research and improvements associated with EBCD were an additional burden. Further barriers included a lack of time and support to engage with projects (even if they provided benefits to patients and staff). Ramos et al. (2019) concluded that 'human barriers' (disbelief in a system's effectiveness due to a lack of previous research) and 'organisational barriers' (lack of time and support for staff to engage with research) were the main barriers to design-based research benefiting healthcare services successfully.

West (2020) built on these ideas, concluding that without the buy-in of stakeholder groups critical for product implementation, products would fail to reach a commercialised state in a healthcare setting. As mentioned earlier, West (2020) hypothesised that if designs aimed to improve existing designs within similar functional and financial constraints, adoption was more likely to occur. Based on this research, clear barriers exist to adopting design research in a healthcare setting. As a result, I wanted to take the ideas discussed by West (2020) and explore products that build off the existing systems to appear more feasible and acceptable to stakeholders while presenting improvements.

Next Steps

Along with considering a wider range of participants for the earlier stages of the design process, the final system I developed would need to include more user feedback before it could be taken further. Within the timeframe of the research, although users were able to provide feedback throughout the design process, the ability to gather user feedback on the final design was not possible. If I had the chance to continue this research further, I would take the products I have produced and explore user feedback on these in settings other than the Waitematā DHB.

Along with gathering more user feedback, another key step towards a viable product would be working with Baxter to understand better the way that the existing infusers were produced to allow for the infuser I have decided to be functionally suitable. Along with this, for the products to be produced or used within a medical setting, the devices would need to be approved for medical use.

The participants of this research were a reasonably homogeneous group. All four patient participants identified as male. Three patient participants were New Zealand European (Pākehā) with one Pacifica participant. All participants were over 40 years of age. Although the group was quite similar, their experiences within the service were all very different. They had been provided with the same service, but each patient had different experiences. This difference of experiences highlights the way that healthcare services can treat patients the same while their outcomes may be very diverse (Campinha-Bacote, 2003). There is an existing body of evidence that suggests that racial biases are present in many health services (Cormack et al., 2018; Williams & Wyatt, 2015). These can negatively impact the health outcomes of many people. In New Zealand, racial biases in healthcare disproportionately affect Māori and

Pacifica peoples (Hall et al., 2015; Harris et al., 2019). Accessibility of medical devices has played a critical role in the findings of my research, exploring how the inclusion of incremental changes to existing products could make medical devices more usable for patients and for my research to be more accessible, I would like to include the voices of groups marginalised by existing healthcare systems more directly in the research. The inclusion of Māori and Pacifica participants could be increased with further research recruitment methods that are better suited to these people (Fink et al., 2011; Kearns et al., 2020; Mhurchu et al., 2009). Another method would be working with district health boards that treat more Māori /Pacifica people. The Waitematā DHB had a population of 10.2% Māori and 7.2% Pacifica people (“Enrolment in a primary health organisation”, 2021). These rates could be improved by recruiting participants from district health boards like Counties Health Manakau that had a population of 16.3% Māori and 22% Pacifica peoples (“Enrolment in a primary health organisation”, 2021).

Elastomeric infusion pumps were used for treatments outside of intravenous antibiotic delivery, such as cytostatic drugs (chemotherapy), analgesics (pain killers), and anaesthetics (Baxter, 2021). Some of these treatments can last for longer than the OPIVA service in Waitematā DHB (Alpenberg et al., 2015). Many of the parts of the OPIVA service were used in these services, and the issues highlighted by the OPIVA patients would likely be even more profound if treatments lasted for longer periods of time (Alpenberg et al., 2015). As well as exploring the OPIVA system within the context of more OPIVA services, I would want to explore if the findings of this research could provide insights into how other treatment systems that used elastomeric infusion devices may be improved with human-centred design methods.

08. References

- 3M. (2021). *Scotch Extremely Strong Mounting Strips 414P-ST, 1 in x 3 in (25,4 mm x 7,62 cm)*. 3M. https://www.3mnz.co.nz/3M/en_NZ/p/d/v000313554/
- A Custom-fitted Clew Strap: Velcro, buckle, or hitch? PS compares the pros and cons of each approach. (2019). *Practical Sailor*, 45(8), 12–15.
- Ackermann, M., Maier, S., Ing, H., & Bonnabry, P. (2007). Evaluation of the design and reliability of three elastomeric and one mechanical infusers. *Journal of Oncology Pharmacy Practice*, 13(2), 77–84. doi: 10.1177/1078155207078349
- Adams. (2021). *Weight ratings and technical information on Adams Suction Cups range*. Suction Cups Direct. <https://www.suctioncupsdirect.co.uk/Weight-Ratings--Technical/122.htm>
- Adlin, T., & Pruitt, J. (2006). *The persona lifecycle: Keeping people in mind throughout product design*. San Francisco, United States: Morgan Kaufmann.
- Aifah, A., Okeke, N. L., Rentrope, C. R., Schexnayder, J., Bloomfield, G. S., Bosworth, H., Grover, K., Hileman, C. O., Muiruri, C., Oakes, M., Webel, A. R., Longenecker, C. T., & Vedanthan, R. (2020). Use of a human-centred design approach to adapt a nurse-led cardiovascular disease prevention intervention in HIV clinics. *Progress in Cardiovascular Diseases*, 63(2), 92–100. doi: 10.1016/j.pcad.2020.02.013
- Al-Busaidi, Z. Q. (2008). Qualitative Research and its Uses in Health Care. *Sultan Qaboos University Medical Journal*, 8(1), 11–19.
- Almakky, A. G. A. (2017). *Wearable medical devices in use : a study of insulin pump adoption by young diabetic patients in Saudi Arabia*.
- Alpenberg, S., Joelsson, G., & Rosengren, K. (2015). Feeling Confident in Using PICC Lines: Patients' Experiences of Living with a PICC Line During Chemotherapy Treatment. *Home Health Care Management & Practice*, 27(3), 119–125. doi: 10.1177/1084822314566300
- Anderson, G. J. (2012). HDPE-TPS bottle returns double environmental benefit. *Plastics Engineering*, 68(6), 48–51. doi: 10.1002/j.1941-9635.2012.tb00859.x
- Ayliffe, G. A. J. (2000). *Control of hospital infection: a practical handbook* (4th ed.). Arnold.
- Bannon, L. J., & Ehn, P. (2013). Design matters in participatory design. In J. Simonsen & T. Robertson (Eds.), *Routledge international handbook of participatory design* (pp. 37-63). Routledge.
- Barnes, C., & Melles, G. (2007). *Managing Interdisciplinarity: A Discussion of the Contextual Review in Design Research*. Presented at the International Association of societies of Design Research Conference, Hong Kong. https://www.sd.polyu.edu.hk/iasdr/proceeding/papers/MANAGING%20INTERDISCIPLINARITY_%20A%20DISCUSSION%20OF%20THE%20CONTEXTUAL%20REVIEW%20IN%20DESIGN%20RESEARCH.pdf
- Barton, A. (2009). Patient Safety and Quality: An Evidence-Based Handbook for Nurses. *AORN Journal*, 90(4), 601–602.
- Baum, F. (2006). Participatory Action Research. *Journal of Epidemiology & Community Health* 60(10), 854-857. doi: 10.1136/jech.2004.028662.
- Baxter, M. (1995). *Product design : a practical guide to systematic methods of new product development*. CRC Press.
- Baxter. (2017). *Elastomeric Products Professional Guide*. Baxter Professionals. <https://baxterprofessionals.co.nz>.
- Bazzano, A. N., Martin, J., Hicks, E., Faughnan, M., & Murphy, L. (2017). Human-centred design in global health: A scoping review of applications and contexts. *PLoS ONE*, 12(11), 1–24. doi: 10.1371/journal.pone.0186744
- Benger, J., & Blackham, J. (2009). Why Do We Put Cervical Collars on Conscious Trauma Patients? *Scandinavian Journal of Trauma, Resuscitation and Emergency Medicine*,

17(1), 44. doi: 10.1186/1757-7241-17-44

- Berkett, T., & Walford, A. (2013). Nurse led PICC line service. *Dissector*, 41(2), 19–21.
- Besnard, D., & Bastien-Toniazzo, M. (1999). Expert error in trouble-shooting: an exploratory study in electronics. *International Journal of Human-Computer Studies* 50(5), 391–405. <https://hal.archives-ouvertes.fr/file/index/docid/691823/filename/Besnard-Bastien-Toniazzo-1999--Expert-error-troubleshooting.pdf>
- Bhuvanewar, C. G., Epstein, L. A., & Stern, T. A. (2007). Reactions to amputation: Recognition and treatment. *Primary Care Companion to the Journal of Clinical Psychiatry*, 9(4), 303.
- Bi, Z., & Wang, X. (2020). *Computer aided design and manufacturing*. Wiley.
- Bjerknes, G., & Bratteteig T. (1987). *Florence in Wonderland: System development with nurses*. University of Oslo.
- Blackler, A., Popovic, V., & Mahar, D. (2003). The nature of intuitive use of products: an experimental approach. *Design Studies*, 24(6), 491. [https://doi-org.ezproxy.aut.ac.nz/10.1016/S0142-694X\(03\)00038-3](https://doi-org.ezproxy.aut.ac.nz/10.1016/S0142-694X(03)00038-3)
- Boateng, J. S., Matthews, K. H., Stevens, H. N., & Eccleston, G. M. (2008). Wound healing dressings and drug delivery systems: a review. *Journal of Pharmaceutical Science* 97(8): 2892-923. doi: 10.1002/jps.21210. PMID: 17963217.
- Boess, S. (2008). *First steps in role playing*. Paper presenting at the Human Factors in Computing Systems Conference, Florence, Italy. doi: 10.1145/1358628.1358632.
- Bogner, A., Littig, B., & Menz, W. (Eds.). (2009). *Interviewing Experts*. Palgrave Macmillan.
- Boradkar, P. (2010). Beautiful Things: The Aesthetics of Surfaces. In Boradkar, P. (Eds.), *Designing things : a critical introduction to the culture of objects* (pp. 127–158). Berg. doi: 10.5040/9781350036116-ch006
- Boy, G. A. (2011). *The Handbook of Human-Machine Interaction: A Human-Centered Design Approach*. Ashgate.
- Burgert, S. L., & Anderson, C. F. (1979). An Evaluation of Upper Arm Measurements Used in Nutritional Assessment. *The American Journal of Clinical Nutrition*, 32(10), 2136–2142, doi: 10.1093/ajcn/32.10.2136
- Campinha-Bacote, J. (2003). Many faces: addressing diversity in health care. *Online Journal of Issues in Nursing*, 8(1), 3.
- Capdevila X., Macaire P., Aknin P., Dadure C., Bernard N., Lopez S. (2003) Patient-controlled perineural analgesia after ambulatory orthopaedic surgery: a comparison of electronic versus elastomeric pumps. *Anesthesia Analog*, 96(2), 414-17.
- Capes, D. F., & Asimwe, D. (1998). Performance of Selected Flow-Restricting Infusion Devices. *American Journal of Health-System Pharmacy*, 55(4), 351-9.
- Capital & Coast District Health Board. (2015). Adult Tracheostomy Care - Patient Information. Capital & Coast District Health Board. <https://www.ccdhb.org.nz/our-services/a-to-z-of-our-services/ear-nose-and-throat/1100830-adult-tracheostomy-care.pdf>
- Carol A. D., Sophia, Z., Don, B., Knashawn H. M., & John B. M. (2006). Body mass index, waist circumference and waist to hip ratio and change in sex steroid hormones: the Massachusetts Male Ageing Study. *Clinical Endocrinology*, 65(1), 125–131.
- Caspari, S., Nåden, D., & Eriksson, K. (2007). Why not ask the patient? An evaluation of the aesthetic surroundings in hospitals by patients. *Quality Management in Health Care*, 16(3), 280–292. doi: 10.1097/01.qmh.0000281064.60849.a6
- Castner, J., Sullivan, S., Titus, A. H., and Klingman, K. J. (2008). Strengthening the Role of Nurses in Medical Device Development. *Journal of Professional Nursing* 32(4), 300–305. doi: 10.1016/j.profnurs.2016.01.002.

- Chambers, S. T., Basevi, A., Carswell-Monya, A., Isenman, H., Pithie, A., Dalton, S., & Metcalf, S. C. (2019). Outpatient Parenteral Antimicrobial Therapy (OPAT) in Christchurch: 18 Years On. *The New Zealand Medical Journal*, 132(1501), 21-32.
- Coates, K., & Ellison, A. (2014). *An Introduction to Information Design*. Laurence King Publishing.
- Collins, H. (2010). *Creative research: the theory and practice of research for the creative industries*. AVA Academia.
- Colour palette - Medical Research Council. (2021). Mrc.ukri.org. Retrieved 6 March 2021, from <https://mrc.ukri.org/about/information-standards/mrc-brand-guidelines/colour-palette/>.
- Colyar, M. R. (2020). *Advanced Practice : Nursing Procedures* (2nd ed.). F.A. Davis.
- Cormack, D., Harris, R., Jones, R., Curtis, E., Stanley, J., & Lacey, C. (2018). Ethnic bias amongst medical students in Aotearoa/New Zealand: Findings from the Bias and Decision Making in Medicine (BDMM) study. *PLoS ONE*, 13(8), 1–19. doi: 10.1371/journal.pone.0201168
- Corona, L. J., Simmons, G. H., Nessler, J. A., & Newcomer, S. C. (2018). Characterisation of regional skin temperatures in recreational surfers wearing a 2-mm wetsuit. *Ergonomics*, 61(5), 729–735. doi: 10.1080/00140139.2017.1387291
- Couto, L. (2021). OHC - Home Breath Analysis. Behance. <https://www.behance.net/gallery/103052883/ohc-Home-Breath-Analysis>.
- Criado-Perez, C. (2019). *Invisible Women: Exposing Data Bias in a World Designed for Men*. Abrams Press.
- Culverwell, E., Jar, W., Barratt, R., Francis, P., & Berger, S. (2020). Do subcutaneously engineered stabilisation devices reduce PICC migration? A product evaluation report. *Australian Journal of Cancer Nursing*, 21(2), 15–20. doi: 10.33235/ajcn.21.2.15-20
- Dankl, K. (2013). Style, Strategy and Temporality: How to Write an Inclusive Design Brief? *The Design Journal*, 16(2), 159-174, doi: 10.2752/175630613X13584367984866
- Diaz, L., Reunanen, M., & Salmi, A. (2009). *Role Playing and Collaborative Scenario Design Development*. Presented at the International Conference of Engineering Design, Stanford, United States of America. <https://www.designsociety.org/download-publication/28727/Role+playing+and+collaborative+scenario+development>.
- Dickson, C. (2017). *From Stigma to Silver Linings: Improving the Experiences of Long-Term Tracheostomy Users Through Product Design*. Auckland University of Technology.
- Dickson, C., Reay, S. D., Douglas, R., & Nakarada-Kordic, I. (2017). Co-design to understand the tracheostomy product experiences of long-term tracheostomy users. *Design for Health*, 1(2), 272–289.
- Dodd, S. (2007). IV therapy. Assessing patient preference for two types of elastomeric infusion device. *British Journal of Nursing*, 16(19), 1180–1185. doi: 10.12968/bjon.2007.16.19.27356
- Feitosa Cestari, V. R., Leite Sampaio, L. R., Victor Barbosa, I., Borges Studart, R. M., Fernandes Moura, B. B., & Cavalcante Araújo, A. R. (2015). Healthcare Technologies Used in Nursing to Care for Polytraumatized Patients: An Integrative Review. *Cogitare Enfermagem*, 20(4), 697–705.
- Fink, J. W., Paine, S. J., Gander, P. H., Harris, R. B., & Purdie, G. (2011). Changing response rates from Māori and non-Māori in national sleep health surveys. *New Zealand Medical Journal*, 124(1328), 52–63.
- Fischer, A. (2015). *Sewing for fashion designers*. Laurence King Publishing.
- Fisher and Paykel Healthcare. (2021). Evora Nasal Mask. <https://www.fphcare.com/us/homecare/sleep-apnea/masks/evora-nasal-mask/>.

- Flaskerud, J. H., Winslow, B. J. (1998). Conceptualizing Vulnerable Populations Health-Related Research. *Nursing Research* 47(2), 69-78.
- Fletcher, K. (2012). Durability, Fashion, Sustainability: The Processes and Practices of Use. *The Journal of Design, Creative Process & the Fashion Industry*, 4(2), 221-238. doi: 10.2752/175693812X13403765252389
- Forcinio, H. (2020). Prioritizing Sustainable Packaging: Pharmaceutical companies work toward a circular economy. *Pharmaceutical Technology Europe*, 32(1), 63-65.
- Franchetti, M., & Kress, C. (2017). An economic analysis comparing the cost feasibility of replacing injection molding processes with emerging additive manufacturing techniques. *International Journal of Advanced Manufacturing Technology*, 88(9-12), 2573-2579. doi: 10.1007/s00170-016-8968-7
- Freeman, C., Marcketti, S., & Karpova, E. (2017). Creativity of images: using digital consensual assessment to evaluate mood boards. *Fashion and Textiles*, 4(1), 1-15. doi: 10.1186/s40691-017-0102-4
- Garmer, K., Ylven, J., & Karlsson. I. C. M. (2004). User participation in requirements elicitation comparing focus group interviews and usability tests for eliciting usability requirements for medical equipment: a case study. *International Journal of Industrial Ergonomics* 33(2), 85-98. doi: 10.1016/j.ergon.2003.07.005
- Garner, S., & McDonagh-Philp, D. (2001). Problem interpretation and resolution via visual stimuli: The use of "mood boards" in design education. *International Journal of Art and Design Education*, 20(1), 57-64. doi: 10.1111/1468-5949.00250
- Gecol, H., Scamehorn, J. F., Christian, S. D., & Riddell, F. E. (2003). Use of surfactants to remove solvent-based inks from plastic films. *Colloid and Polymer Science*, 281(12), 1172-1177. doi: 10.1007/s00396-003-0891-4.
- Gecol, H., Scamehorn, J.F., Christian, S.D., Grady, B.P. and Riddell, F.E. (2002), Deinking of water-based ink printing from plastic film using nonionic surfactants. *Journal of Surfactants and Detergents*, 5(4), 363-374. doi: 10.1007/s11743-002-0235-8
- Gerring, J. (2007). *Case study research : principles and practices*. Cambridge University Press.
- Ghomi, E. R., Khalili, S., Khorasani, S. N., Neisiany, R. E., & Ramakrishna, S. (2019). Wound dressings: Current advances and future directions. *Journal of Applied Polymer Science*, 136(27). doi: 10.1002/app.47738
- Ghosh, A., Rajeev, R. S., Bhattacharya, A. K., Bhowmick, A. K., & De, S. K. (2003). Recycling of Silicone Rubber Waste: Effect of Ground Silicone Rubber Vulcanizate Powder on the Properties of Silicone Rubber. *Polymer Engineering & Science*, 43(2), 279. doi: 10.1002/pen.10024
- Giacomin, J. (2015). What is Human Centred Design? *The Design Journal*, 17(4), 606-623. doi: 10.2752/175630614X14056185480186.
- Gigante, N., Montanari, A., Mayer, M. C., & Orlandini, A. (2017). Complexity of Timeline-Based Planning. *Proceedings of the International Conference on Automated Planning and Scheduling*, 27(1). <https://ojs.aaai.org/index.php/ICAPS/article/view/13830>
- Göhler, S. M., Ebro, M., & Howard, T. J. (2018). Mechanisms and coherences of robust design methodology: a robust design process proposal. *Total Quality Management & Business Excellence*, 29(3/4), 239-259. doi: 10.1080/14783363.2016.1180952
- Golden, B., Rosemary, H., Heather, F., Mark, L., Sarah, D., Janice, S., & Eugene, G. (2011). Improving the Patient Experience through Design. *Healthcare Quarterly* 14(3), 32-41. doi: 32-41. 10.12927/hcq.2011.22488.
- González López, J. L., Arribi Vilela, A., Fernández del Palacio, E., Olivares Corral, J., Benedicto Martí, C., & Herrera Portal, P. (2014). Indwell times, complications and costs of open vs closed safety peripheral intravenous catheters: a randomized

- study. *Journal of Hospital Infection*, 86(2), 117–126.
- Gray, D. E. (2018). *Doing research in the real world* (4th ed.). SAGE.
- Greenhalgh, P., & Balloffet, C. (2021). The role of colour in medical devices: a designer's perspective. Teamconsulting.com. <https://www.team-consulting.com/insights/the-role-of-colour-in-medical-devices-a-designers-perspective/>
- Gregory, I. (2003). *Ethics in research*. Continuum.
- Griffiths, R. (2004). Knowledge production and the research-teaching nexus: The case of the built environment disciplines. *Studies in Higher Education*, 29(6), 709–726. doi: 10.1080/0307507042000287212
- Hägglund, S. (1993). Introducing expert critiquing systems. *Knowledge Engineering Review*, 8(4), 281.
- Hall, W. J., Chapman, M. V., Lee, K. M., Merino, Y. M., Thomas, T. W., Payne, B. K., Eng, E., Day, S. H., & Coyne-Beasley, T. (2015). Implicit Racial/Ethnic Bias Among Health Care Professionals and Its Influence on Health Care Outcomes: A Systematic Review. *American Journal of Public Health*, 105(12), e60–e76. doi: 10.2105/AJPH.2015.302903
- Hamilton, B., & Sahatjian, R. A. (2012). *Medical Device Balloons Containing Thermoplastic Elastomers* (U.S. Patent No. 2012/0016405 A1). U.S. Patent and Trademark Office. <https://patents.google.com/patent/US20120016405A1/en>
- Harris, R. B., Cormack, D. M., & Stanley, J. (2019). Experience of racism and associations with unmet need and healthcare satisfaction: the 2011/12 adult New Zealand Health Survey. *Australian & New Zealand Journal of Public Health*, 43(1), 75–80. doi: 10.1111/1753-6405.12835
- Harte, R., Glynn, L., Rodríguez-Molinero, A., Baker, P. M., Scharf, T., Quinlan, L. R., & ÓLaighin, G. (2017). A Human-centred Design Methodology to Enhance the Usability, Human Factors, and User Experience of Connected Health Systems: A Three-Phase Methodology. *JMIR Human Factors*, 4(1), e8. doi: 10.2196/humanfactors.5443
- Hartswood, M., Procter, R., Slack, R., Vob, A., Buscher, M., Rouncefield, M., & Rouchy, P. (2002). Co-realisation: Towards a Principled Synthesis of Ethnomethodology and Participatory Design. *Scandinavian Journal of Information Systems*, 14(2), 2.
- Hassan, Y. R., El Farahaty, M. A., Ibrahim, S. I., & Nassar, M. A. (2019) Design and producing blowing mold using Additive manufacturing. *International Design Journal*, 9(4), 73-78. <https://digitalcommons.aaru.edu.jo/cgi/viewcontent.cgi?article=1161&context=faa-design>
- Hempel, S. (2020). *Conducting Your Literature Review*. American Psychological Association.
- Hendrickson, G., Doddato, T. M., & Kovner, C. T. (1990). How do nurses use their time? *Journal of Nursing Administration*, 20(3), 31–37. doi: 10.1097/00005110-199003000-00008
- Hoffman, A. R. (2020). *Sketching as design thinking*. Routledge.
- Hopewell, J. (2009). Plastics recycling: challenges and opportunities. *Philosophical Transactions of the Royal Society B: Biological Sciences*, 364(1526), 2115–2126. doi: 10.1098/rstb.2008.0311
- Howard, T. (2014). Journey mapping: a brief overview. *Communication Design Quarterly* 2(3), 10–13. doi: 10.1145/2644448.2644451
- Hughes, M. E. (2014). Reducing PICC migrations and improving patient outcomes. *British Journal of Nursing*, 23(2), S12–S18. doi: 10.12968/bjon.2014.23.Sup1.S12
- IDEO. (2015). *Field Guide to Human-Centered Design* (1st ed.). Ideo.org.
- International Organization for Standardization. (2010). *Ergonomics Of Human-System Interaction – Human-Centred Design for Interactive Systems* (ISO Standard No.

- 9241-210) <https://www.iso.org/standard/52075.html>
- Intravenous bolus. (2012) Medical Dictionary for the Health Professions and Nursing. <https://medical-dictionary.thefreedictionary.com/intravenous+bolus>
- Jacobson, A. F., Warner, A. M., Fleming, E., & Schmidt, B. (2008). Factors influencing nurses' participation in clinical research. *Gastroenterology Nursing, 31*(3), 198-208. doi: 10.1097/01.SGA.0000324112.63532.a2.
- Jaenichen, C. (2017). Teaching advocacy and evidence-based design to undergraduate graphic design students. *Information Design Journal, 23*(3), 334-356. doi: 10.1075/idj.23.3.06jae
- Jamshidi, N., Molazem, Z., Sharif, F., Torabizadeh, C., & Najafi Kalyani, M. (2016). The Challenges of Nursing Students in the Clinical Learning Environment: A Qualitative Study. *Scientific World Journal 2016*, 1-7. doi: 10.1155/2016/1846178
- Jeanes, A., & Martinez-Garcia G. (2016). Intravenous Securement Devices: An Overview. *British Journal of Healthcare Management, 22*(10), 488-492. doi: 10.12968/bjhc.2016.22.10.488
- Johnston, R. G. (2003). *Tamper-indicating seals : practices, problems, and standards*. Conference: Submitted to: World Customs Organization Security Meeting. Belgium.
- Jowett, N. I., & Robinson C. G. F. (1995) The tight pants syndrome - A sporting variant. *Postgraduate Medical Journal, 72*(846), 239-240. doi: 10.1136/pgmj.72.846.239
- Kearns, C., Baggott, C., Harwood, M., Reid, A., Fingleton, J., Levack, W., & Beasley, R. (2020). *Engaging Māori with qualitative healthcare research using an animated comic*. Health Promotion International. hdoi: 10.1093/heapro/daaa111
- Khadori, N. (2014). *Sepsis : Diagnosis, Management and Health Outcomes*. Nova Science Publishers, Inc.
- KHS cuts packaging with direct printing on PET bottles, adhesive multi-packs. (2015). *Popular Plastics & Packaging, 60*(5), 41-43.
- Kimbell, L. (2014). *Service Innovation Handbook*. BIS Publishers.
- Kipper, J. (2013). What is conceptual analysis and what is the problem?. In *A Two-Dimensionalist Guide to Conceptual Analysis* (pp. 9-20). De Gruyter. doi: 10.1515/9783110322705.9
- Kleber, J., & Cohen, B. (2020). Reducing Waste and Increasing Sustainability in Health Care Settings: Changing the way plastic medical waste is used and disposed of. *AJN American Journal of Nursing, 120*(4), 45-48. doi: 10.1097/01.naj.0000660032.02514.ec
- Kohn, L. T., Corrigan, J., & Donaldson, M. S. (2000). *To err is human: building a safer health system*. National Academy Press.
- Kumari, P., Thomas, M., Ritchie, S., & Jull, A. (2018). The Patient Experience of Care Delivered by an Outpatient Intravenous Antibiotic Service. *Kai Tiaki Nursing Research, 9*(1), 18-26.
- Kunt, Z. (2020). Art-based methods for Participatory Action Research (PAR). *Interactions: Studies in Communication & Culture, 11*(1), 87-96. doi: 10.1386/iscc_00008_1
- Labattaglia, O., Reay, S., & Nakarada-Kordic, I. (2019). *Accessible co-design: a thesis submitted to Auckland University of Technology in partial fulfilment of the requirements for the degree of Master of Philosophy*. Auckland University of Technology.
- Lam, K., Tanenbaum, J., & Ott, S. (2008). *History of Nursing*. Insight Media.
- Langdon, P. (2014). *Inclusive designing: joining usability, accessibility, and inclusion*. Springer.
- Lapan, S. D., Quartaroli, M. T., & Riemer, F. J. (2012). *Qualitative research: an introduction to methods and designs* (1st ed.). Jossey-Bass.

- Leistikow, I. (2017). *Prevention is better than cure: learning from adverse events in healthcare*. CRC Press.
- Lever, A., & Mackenzie, I. (2007). Sepsis: Definition, Epidemiology, and Diagnosis. *The BMJ*, 335(879), doi: 10.1136/bmj.39346.495880.AE
- Li, W., Branley, J., & Sud, A. (2018). Outpatient parenteral antibiotic therapy in a suburban tertiary referral centre in Australia over 10 years. *Infection*, 46(3), 349–355. doi: 10.1007/s15010-018-1126-4
- Li, W.-T., Ho, M.-C., & Yang, C. (2019). A Design Thinking-Based Study of the Prospect of the Sustainable Development of Traditional Handicrafts. *Sustainability*, 11(18). doi: 10.3390/su11184823
- Liem, A. (2019). *The role of prototyping in ergonomic practice and research to anticipate new products and services* (Vol. 824). Springer Verlag. doi: 10.1007/978-3-319-96071-5_47
- Lin, L., Vicente, K., & Doyle, D. (2001). Patient safety, potential adverse drug events, and medical device design: A human factors engineering approach. *Journal of biomedical informatics*, 34(4), 274–284. doi: 10.1006/jbin.2001.1028
- Louise Barriball, K., & While, A. (1994). Collecting data using a semi-structured interview: a discussion paper. *Journal of Advanced Nursing*, 19(2), 328–335. doi: 10.1111/j.1365-2648.1994.tb01088.x
- LUMA Institute. (2012). *Innovating for People: Handbook of human-centered design methods*. LUMA Institute.
- Marler-Hausen, T., Holt, C., Headley, C., & Sessink, P. (2020). Use of a closed-system drug transfer device reduces contamination with doxorubicin during bolus injection. *British Journal of Nursing*, 29(10), S15–S21. hdoi: 10.12968/bjon.2020.29.10.S15
- Martin, J. L., Norris, B. J., Murphy, E., & Crowe J. A. (2008). Medical device development: The challenge for ergonomics. *Applied Ergonomics*, 39(3), 271–283. doi: 10.1016/j.apergo.2007.10.002.
- McDermott, C. J., & Shaw, P. J. (2008). Diagnosis and management of motor neurone disease. *BMJ (Clinical Research Ed.)*, 336(7645), 658–662. doi: 10.1136/bmj.39493.511759.BE
- McGarrell, C. (2021). Sensile Medical Design Language. Craig McGarrell. <http://www.craigmgarrell.com/sensilemedical>
- McNiff, J. (2013). *Action Research: Principles and Practice* (3rd ed.). Routledge.
- McNiff, J. (2017). *Action Research: All You Need to Know*. Sage.
- Merriam, B. S., & Tisdell, E. J. (2016). *Qualitative Research: A Guide to Design and Implementation*. (4th ed.). Jossey-Bass.
- Mhurchu, C. N., Blakely, T., Funaki-Tahifote, M., McKerchar, C., Wilton, J., Chua, S., & Jiang, Y. (2009). Inclusion of indigenous and ethnic minority populations in intervention trials: challenges and strategies in a New Zealand supermarket study. *Journal of Epidemiology and Community Health*, 63(10), 850–855. doi: 10.1136/jech.2008.081109
- Ministry of Health. (2015). Understanding Excess Body Weight: New Zealand Health Survey. Ministry of Health. <https://www.health.govt.nz/system/files/documents/publications/understanding-excess-body-weight-nzhs-apr15-v2.pdf>
- Money, A. G., Barnett, J., Kuljis, J., Craven, M. P., Martin, J. L., & Young, T. (2011). The role of the user within the medical device design and development process: medical device manufacturers' perspectives. *BMC Medical Informatics and Decision Making* 11(15), 15. doi: 10.1186/1472-6947-11-15
- Nadler, G. (1980). A timeline theory of planning and design. *Design Studies*, 1(5), 299–307. doi: 10.1016/0142-694X(80)90064-2

- Nakarada-Kordic, I., Hayes, N., Reay, S. D., Corbet, C., & Chan, A. (2017). Co-designing for mental health: creative methods to engage young people experiencing psychosis. *Design for Health, 1*(2), 229–244. doi: 10.1080/24735132.2017.1386954
- Neuman, W. L. (2014). *Social research methods: qualitative and quantitative approaches* (7th ed.). Pearson.
- New Zealand Government. (2021). Enrolment in a primary health organisation. Ministry of Health. Retrieved May 27, 2021, from <https://www.health.govt.nz/our-work/primary-health-care/about-primary-health-organisations/enrolment-primary-health-organisation>.
- Nicholson, J., & Davies, L. (2013). Patients' Experiences of the PICC Insertion Procedure. *British Journal of Nursing, 22*(9), S16-S23. doi: 10.12968/bjon.2013.22.Sup9.S16
- Norman, D. A., Draper, S. W., (1986). *User Centred System Design: New Perspectives on Human-Computer Interaction*. Lawrence Erlbaum Associates.
- Null, R. (2014). *Universal design: principles and models*. CRC Press.
- Obendorf, H. (2007). *Where "less" is "more" - notions of minimalism and the design of interactive systems: A constructive analysis of products & processes of human-computer-interaction design from a minimalist standpoint*. University of Hamburg. <https://ediss.sub.uni-hamburg.de/handle/ediss/2132>
- Obendorf, H. (2009). *Minimalism : designing simplicity*. Springer.
- Ojo, S. A. (2020). Reflections on setting up a nurse-led paediatric peripherally inserted central catheter service. *British Journal of Nursing, 29*(14), S16–S20. doi: 10.12968/bjon.2020.29.14.S16
- Parbhu, N., Reay, S., Landhuis, E., & Water, T. (2019). Differing perspectives: Evaluation of a new IV pole by children and adults. *Journal of Child Health Care, 23*(4), 551–563.
- Parkin, P. (2009). *Managing change in healthcare: using action research*. Sage.
- Parsons, T. (2009). *Thinking, Objects: Contemporary Approaches to Product Design*. AVA Academia.
- Patrick W. J. (2000). *Designing Pleasurable Products: An Introduction to the New Human Factors*. Taylor & Francis.
- Patro, A., Priya, V., Riaz, R., & Dhiraaj, S. (2016). Elastomeric balloon pump: Use of triway to fill! *Indian Journal of Anaesthesia, 60*(3), 218–219. doi: 10.4103/0019-5049.177882
- Poon A. W. C., Curtis, J., Ward, P., Loneragan, C., & Lappin, J. (2020). Physical and Psychological Health of Carers of Young People with First Episode Psychosis. *Australasian Psychiatry, 26*(2), 184–88. doi: 10.1177/1039856217748250.
- Poon, A. W. C., Curtis, J., Ward, P., Loneragan, C., & Lappin, J. (2018). Physical and Psychological Health of Carers of Young People with First Episode Psychosis. *Australasian Psychiatry, 26*(2), 184–188. doi: 10.1177/1039856217748250
- Powell-Cope, G., Nelson, A. L., & Patterson, E. S. (2008). Patient Care Technology and Safety. In: Hughes, R. G., (ed.), *Patient Safety and Quality: An Evidence-Based Handbook for Nurses*. Agency for Healthcare Research and Quality. <https://www.ncbi.nlm.nih.gov/books/NBK2686/>
- Pravossoudovitch, K., Cury, F., Young, S. G., & Elliot, A. J. (2014). Is red the colour of danger? Testing an implicit red-danger association. *Ergonomics, 57*(4), 503–510. doi: 10.1080/00140139.2014.889220
- Preece, A., & Reuschel, W. (2014). *Mobile Connected Health Devices: The Future of Health technology?* Access World Magazine. <https://www.afb.org/afbpress/pub.asp?DocID=aw151107> website.
- Privitera, M. B. (2019). *Applied Human Factors in Medical Device Design*. Elsevier.
- Ramos, M., Bowen, S., Wright, P. C., Gomes Ferreira M. G., & Forcellini, F. A.

- (2020). Experience based co-design in healthcare services: an analysis of projects barriers and enablers. *Design for Health*, 4(3), 276-295. doi: 10.1080/24735132.2020.1837508
- Rangel-Ribeiro, G. D. S., Da Silva, R. C., & Ferreira, M. A. (2016). Technologies in intensive care: causes of adverse events and implications to nursing. *Revista Brasileira de Enfermagem*, 69(5), 915–923. doi: 10.1590/0034-7167.2016690505.
- Rasoulifar, R., Guillaume Thomann, G., & François Villeneuve, F. (2008). *Integrating an expert user in the Design Process: How to make out surgeon needs during new surgical instruments Design Case study*. Seventh International Symposium on Tools and Methods of Competitive Engineering, Turkey. <https://hal.archives-ouvertes.fr/hal-00276089/document>.
- Reason, P. & Bradbury, H. (2008) *The Sage Handbook of Action Research: Participative Inquiry and Practice*. Sage.
- Reed, H., Langley, J., Stanton, A., Heron, N., Clarke, Z., Judge, S., McCarthy, A., Squire, G., Quinn, A., Wells, O., Tindale, W., Baxter, S., Shaw, P. J., & McDermott, C. J. (2015). Head-Up; An interdisciplinary, participatory and co-design process informing the development of a novel head and neck support for people living with progressive neck muscle weakness. *Journal of Medical Engineering & Technology*, 39(7), 404–410. doi: 10.3109/03091902.2015.1088092
- Rich, D. S. (1992). Evaluation of disposable, elastomeric infusion device in the home environment. *American Journal of Health-System Pharmacy*, 49(7), 1712-16
- Riedel, J. C. K. H., & Pawar, K. S. (1997). The consideration of production aspects during product design stages. *Integrated Manufacturing Systems*, 8(4), 208–214. doi: 10.1108/09576069710182027
- Rizzuto, C., Bostrom, J., Suter, W. N., & Chenitz, W. C. (1994). Predictors of nurses' involvement in research activities. *Western Journal of Nursing Research*, 16(2), 193-204. doi: 10.1177/019394599401600206.
- Rubin, H. R. (1998). Status report--an investigation to determine whether the built environment affects patients' medical outcomes. *Journal of Healthcare Design* 10, 11-3. <https://www.healthdesign.org/sites/default/files/Built%20Environment%20Affects%20Patients%20Medical%20Outcomes.pdf>.
- Sacchetti, L. M., & Mangiardi, P. (2012). *Obstructive sleep apnea : causes, treatment and health implications*. Nova Science Publishers.
- Sadowska, N., & Laffy, D. (2017). The design brief: inquiry into the starting point in a learning journey. *Design Journal*, 20(1), S1380–S1389. doi: 10.1080/14606925.2017.1352664
- Sanders, E. B. N. (2020). An Evolving Map of Design Practice and Design Research. <http://www.dubberly.com/articles/an-evolving-map-of-design-practice-and-design-research.html>.
- Sanders, E. B. N., & Stappers, P. J. (2008). Co-Creation and The New Landscapes of Design. *Codesign* 4(1), 5-18. doi: 10.1080/15710880701875068.
- Sanders, E. B. N., & Stappers, P. J. (2014). Probes, toolkits, and prototypes: three approaches to making in codesigning. *CoDesign*, 10(1), 5–14. doi: 10.1080/15710882.2014.888183
- Sansoni, S., Wodehouse, A., & Buis, A. (2014). *The Aesthetics of Prosthetic Design: From Theory to Practice*. International Design Conference. Dubrovnik. Croatia.
- Sansoni, S., Wodehouse, A., McFadyen, A., & Buis, A. (2015). The Aesthetic Appeal of Prosthetic Limbs and the Uncanny Valley: The Role of Personal Characteristics in Attraction. *International Journal of Design*, 9(1), 67–81.
- Schmidt, F. M., Agassant, J. F., & Bellet, M. (1998). Experimental study and numerical simulation of the injection stretch/blow molding process. *Polymer Engineering*

- and *Science*, 38(9), 1399–1412. doi: 10.1002/pen.10310
- Schuler, D., and Aki Namioka A. (1993). *Participatory Design: Principles and Practices*. L. Erlbaum Associates.
- Scragg, J. (2003). A Critique of the Review of Processes concerning Adverse Medical Events (the Cull Report). *Canterbury Law Review*, 9(1), 37–78.
- Shah, S. G. S., & Robinson, I. (2007). Benefits of and barriers to involving users in medical device technology development and evaluation. *International journal of technology assessment in health care*, 23(1), 131–137.
- Shepperd, S., Gonçalves-Bradley, D. C., Iliffe, S., Doll, H. A., Clarke, M. J., Kalra, L., & Wilson, A. D. (2016). Admission avoidance hospital at home. *Cochrane Database of Systematic Reviews*, 2016(9). doi: 10.1002/14651858.CD007491.pub2
- Shorrock, S., & Williams, C. (2017). *Human Factors and Ergonomics in Practice : Improving System Performance and Human Well-Being in the Real World*. CRC Press.
- Simonse, L., Albayrak, A., & Starre, S. (2019). Patient journey method for integrated service design. *Design for Health*, 3(1), 82–97.
- Simonsen, J., & Robertson, T. (2013). *Routledge international handbook of participatory design*. Routledge.
- Smith, R. N., & Nolan, J. P. (2013). Central venous catheters. *BMJ: British Medical Journal*, 347(7933), 28–32. doi: 10.1136/bmj.f6570
- Smith, S. F., Duell, D. J., Martin, B. C., Gonzalez, L., & Aebersold, M. (2016). Central vascular access devices. In: Smith, S. F., Duell, D. J., Martin, B. C., Gonzalez, L., & Aebersold, M., (ed.). *Clinical Nursing Skills: Basic to Advanced Skills* (9th ed.). Pearson.
- Steck, Wilson, Beth, Mary, and Geter Rice, Jennifer. (2018). How the ANA's Code of Ethics Applies to South Carolina Nurses in Clinical Practice. *South Carolina Nurse* 25(4), 8–9.
- Steen, M. (2011). Tensions in human-centred design. *CoDesign: International Journal of CoCreation in Design and the Arts*, 7(1), 45-60. doi: 10.1080/15710882.2011.563314
- Stevanovic, M., Marjanović, D., & Štorga, Mario, S. (2015). *A Model of Idea Evaluation and Selection for Product Innovation*. Presented at the International Conference on Engineering Design. Milan. Italy.
- Stewart, R. (2016). Bottle Screen Printing vs. Clear Bottle Labels: The Pros and Cons of Both. The Thelablink.com. <https://thelablink.com/bottle-screen-printing-vs-clear-bottle-labels-use-one/>
- Stickdorn, M., & Schneider, J. (2012). *This is service design thinking: basics, tools, cases*. Hoboken: Wiley
- Suen, W. Q., Lim, S., Wang, W., & Kowitlawakul, Y. (2016). Stressors and expectations of undergraduate nursing students during clinical practice in Singapore. *International Journal of Nursing Practice*, 22(6), 574–583. doi: 10.1111/ijn.12473
- Swann, C. (2002). Action Research and the Practice of Design. *Design Issues*, 18(1), 49–61.
- Syndor, D., & J. Aileen. (2020). Hospital Furniture: Expectations of Patients toward Furniture in Healthcare Setting. *Proceedings on Engineering Sciences*, 2(3), 305–310. doi: 10.24874/PES02.03.009
- Tegaderm Safety Data Sheet. 3mz.com. (2021). https://multimedia.3m.com/mws/mediawebsserver?mwsId=S5SSSuUn_zu8l_g14xt958tBlv70k17zHvu9lxtD7SSSSSS--.
- Thibault, F., Malo, A., Lanctot, B., & Diraddo, R. (2007). Preform Shape and Operating Condition Optimization for the Stretch Blow Molding Process. *Polymer Engineering and Science* 47(3), 289-301. doi: 10.1002/pen.20707
- Thiveaud, D., Demazien, V., & Lafont, J. (2005). Comparison of the performance of four

- elastomeric devices. *European Journal of Hospital Pharmacy Practice* 2, 54-56.
- Todd, M. (2018). Assessing skin damage and prevention in elderly patients. *Practice Nursing*, 29(12), 578–581. doi: 10.12968/pnur.2018.29.12.578
- Townsend, C., & Sood, S. (2012). Self-affirmation through the choice of highly aesthetic products. *Journal of Consumer Research*, 39(2), 415-428. doi: 10.1086/663775
- Trombetta, W. L., & Wilson, T. L. (1975). Foreseeability of Misuse and Abnormal Use of Products by the Consumer. *Journal of Marketing*, 39(3), 48–55. doi: 10.1177/002224297503900309
- Tsekleves, E., & Cooper, R. (2017). Emerging Trends and the Way Forward in Design in Healthcare: An Expert's Perspective. *The Design Journal* 20, S2258–S2272. doi: 10.1080/14606925.2017.1352742
- Ulrich R. S. (1991). Effects of interior design on wellness: theory and recent scientific research. *Journal of Health Care International Design*, 1991(3)97-109. PMID: 10123973.
- Ulrich, R. S. (2001). Effects of healthcare environmental design on medical outcomes. In: Dilani A, (Ed.), *Design and Health*. Stockholm, Sweden: Svensk Byggtjänst.
- Upton, A., Ellis-Pegler R. B., & Woodhouse, A. (2004). Outpatient Parenteral Antimicrobial Therapy (OPAT): a review of experience at Auckland Hospital. *New Zealand Medical Journal*, 20(117), 1-9. <https://pubmed.ncbi.nlm.nih.gov/15475990/>
- Valente, M., & Aldrete, J. A. (2005). Comparison of Accuracy and Cost of Disposable, Nonmechanical Pumps Used for Epidural Infusions. *European Respiratory Journal* 22(3), 260-266.
- Van Audenhove L., Donders K. (2019) Talking to People III: Expert Interviews and Elite Interviews. In: Van den Bulck H., Puppis M., Donders K., Van Audenhove L. (Ed.), *The Palgrave Handbook of Methods for Media Policy Research*. Palgrave Macmillan, Cham. doi: 10.1007/978-3-030-16065-4_10
- Vasileiadis, T., Tzotzis, A., Tzetzis, D., & Kyratsis, P. (2019). Combining product and packaging design for increased added value and customer satisfaction. *Journal of Graphic Engineering and Design*, 10(2), 5–15. doi: 10.24867/JGED-2019-2-005
- Vaughan, L. (2017). *Practice-based Design Research*. Bloomsbury Visual Arts.
- Wakabayashi, H., Kaneda, K., Sato, D., Tochiara, Y., & Nomura, T. (2008). Effect of non-uniform skin temperature on thermoregulatory response during water immersion. *European Journal of Applied Physiology*, 104(2), 175–181.
- Wallace, J., McCarthy, J., Wright, P. C., & Olivier, P. (2013). *Making Design Probes Work*. Presented at the SIGCHI conference on Human Factors in Computing Systems. doi: 10.1145/2470654.2466473
- Watts, G., Khan, A., & Pheasant, R. (2016). Influence of soundscape and interior design on anxiety and perceived tranquility of patients in a healthcare setting. *Applied Acoustics*, 104, 135–141. doi: 10.1016/j.apacoust.2015.11.007
- Webb, T. B. (1984). A device for prevention of kinking in intravenous lines. *Anaesthesia*, 39(8), 837. doi: 10.1111/j.1365-2044.1984.tb06547.x
- Wei Zhang, Louise K. Barriball and Alison E. (2014). Nurses Attitudes towards Medical Devices in Healthcare Delivery: A Systematic Review. *Journal of Clinical Nursing*, 23(20), 2725-2739. doi: 10.1111/jocn.12601.
- Wertheimer, A. (1999). What Is Consent and Is It Important. *Buffalo Criminal Law Review*, 3(2), 557–584. doi: 10.1525/nclr.2000.3.2.557
- West, J. (2020). Design in healthcare: the challenge of translation. *Design for Health*, 4(2), 252-269. doi: 10.1080/24735132.2020.1783880.
- Wheeler, A., & Millman, D. (2018). *Designing brand identity: an essential guide for the entire branding team* (5th ed.). Wiley.

Wiklund, E. (2005). Addressing the Problem of Medical Device Misuse. MDDI Qmed. <https://www.mddionline.com/news/addressing-problem-medical-device-misuse>.

Wiklund, M. E., Kendler, J., & Strohlic, A. Y. (2011). *Usability testing of medical devices*. Taylor & Francis.

Williams, D. N., Baker, C. A., Kind, A. C., & Sannes, M. R. (2015). The history and evolution of outpatient parenteral antibiotic therapy (OPAT). *International Journal of Antimicrobial Agents*, 46(3), 307-312. doi: 10.1016/j.ijantimicag.2015.07.001.

Williams, D. R., & Wyatt, R. (2015). Racial Bias in Health Care and Health: Challenges and Opportunities. *JAMA: The Journal of the American Medical Association*, 314(6), 555-556. doi: 10.1001/jama.2015.9260

Willis, J. W. (2014). *Action Research: Models, Methods, and Examples. Applied Research in Education and the Social Sciences*. Information Age Publishing.

Wilson, C. (2013). *Brainstorming and Beyond: A User-Centered Design Method*. Morgan Kaufmann.

Wilson, R. M., Harrison, B. T., Gibberd, R. W., & Hamilton, J. D. (1999). An analysis of the causes of adverse events from the Quality in Australian Health Care Study. *The Medical Journal of Australia*, 170(9), 411-415. doi: 10.5694/j.1326-5377.1999.tb127814.x.

Withell, A., Cochrane, T., Reay, S., Gaziulusoy, I., & Inder, S. (2012). *Augmenting the Design Thinking Studio*. Massey University.

Wrapson, J., Patterson, N., Nakarada-Kordic, I., & Reay, S. (2017). A life-changing event: patients' personal experiences of living with a long-term tracheostomy. *Design for Health*, 1(2), 256-271. doi: 10.1080/24735132.2017.1386432

Yap, Y. S., Karapetis, C., Leroose, S., Iyer, S., & Koczwara, B. (2006). Reducing the risk of peripherally inserted central catheter line complications in the oncology setting.

European Journal of Cancer Care, 15(4), 342-347.

Zahnd, D., Aebi, S., Rusterholz, S., Fey, M. F., & Borner, M. M. (1999). A randomized crossover trial assessing patient preference for two different types of portable infusion-pump devices. *Annals of Oncology*, 10(6), 727-729. doi: 10.1023/A:1008334313918

Zheng, R., Fan, X. J., & Tanner, R. I. (2011). *Injection molding: integration of theory and modeling methods*. Springer.

09. Appendices

09.1. Appendix A.

Expert Interviews Indicative Topics

Indicative topics for interviews with OPIVA treatment USERS

OPIVA User's Experiences:

1. Experiences of the in-patient care related to OPIVA. Nurse/Patient communication and understanding of the OPIVA treatment prior to the treatment.
2. The reality of undertaking OPIVA treatment, were there any key issues you experienced in undertaking activities you would normally be part of your everyday life? (bathing/sleeping/working/physical activity).
3. Self-efficacy – Perception of ability to manage the care of the OPIVA treatment devices. As an outpatient-based care service, were there any key areas of the treatment you found difficult or caused significant issues? (Daily changes of the Baxter infuser/keeping the PICC site dry or clean/ storage and care of the Baxter infuser during the day-to-day activities)
4. Fears involved as an OPIVA treatment user. Did you experience significant anxiety/distress prior to and during your treatment with OPIVA?
5. Is there anything positive about having the OPIVA treatment? (Excluding that treatment occurred in an outpatient rather than inpatient.)

User Insights on the OPIVA Design:

1. Effective aspects of the existing design of the OPIVA treatment devices; what could be changed and why?
2. Communication – information provided to the OPIVA treatment users/ assessing healthcare services regarding communication both prior to and during treatment. Communication material and nurse/patient communication.
3. Design – What improvements could be made to the existing design, and what changes have the potential to help improve the experience of having to use the OPIVA treatment devices?

Indicative topics for interviews with OPIVA Clinical Staff

OPIVA Clinical Staff Experiences:

1. Clinician's role in the OPIVA service – the clinical staff member role in the OPIVA service, inpatient/outpatient setting, describe your role in providing care to patients.
2. As a care provider, describe an average experience in a patient/carer interaction. (An inpatient care setting and initially educating them / caring for a patient in an outpatient setting as a district nurse/pharmacists' role / etc.).
3. The OPIVA treatment pathway, what are your personal experiences of the OPIVA treatment as a care provider? What aspects of the current treatment do you feel are positive, and which areas do you feel could use improvement and are difficult or time consuming for you as a care provider?

Clinical Staff Insights on the OPIVA Design:

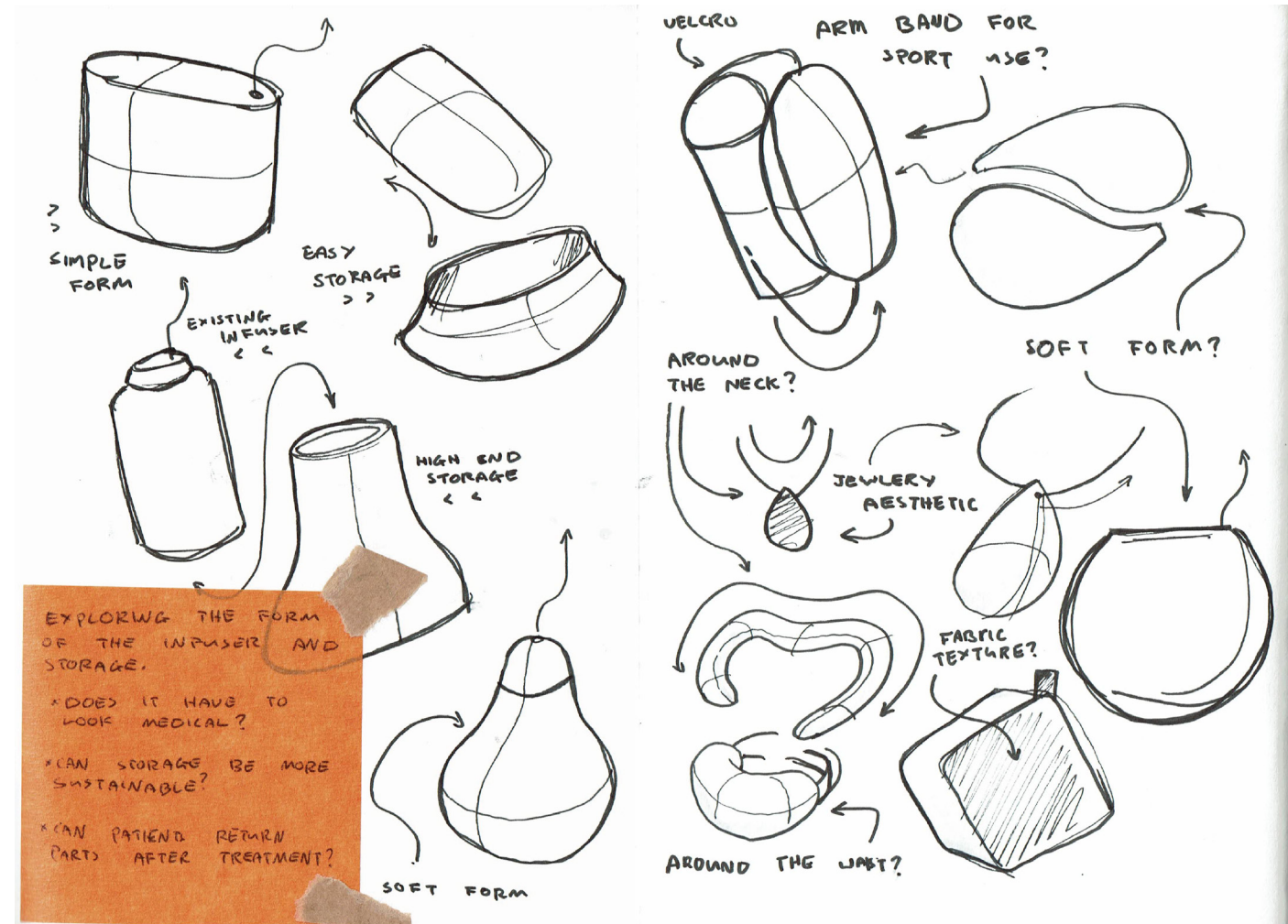
1. Effective aspects of the existing design of the OPIVA treatment devices; what could be changed and why based on your experiences with the devices as a clinician?
2. Communication – information provided to the OPIVA treatment users/ assessing healthcare services regarding communication both prior to and during treatment. Communication material and nurse/patient communication. Are there concepts/processes of the care that you find

difficult to communicate to patients, or in your experience's patients have difficulty adhering to?

3. Design – What improvements could be made to the existing design, and what changes have the potential to help improve the experience of having to use the OPIVA treatment devices as a care provider? (Dressing changes/ PICC line management/etc.).

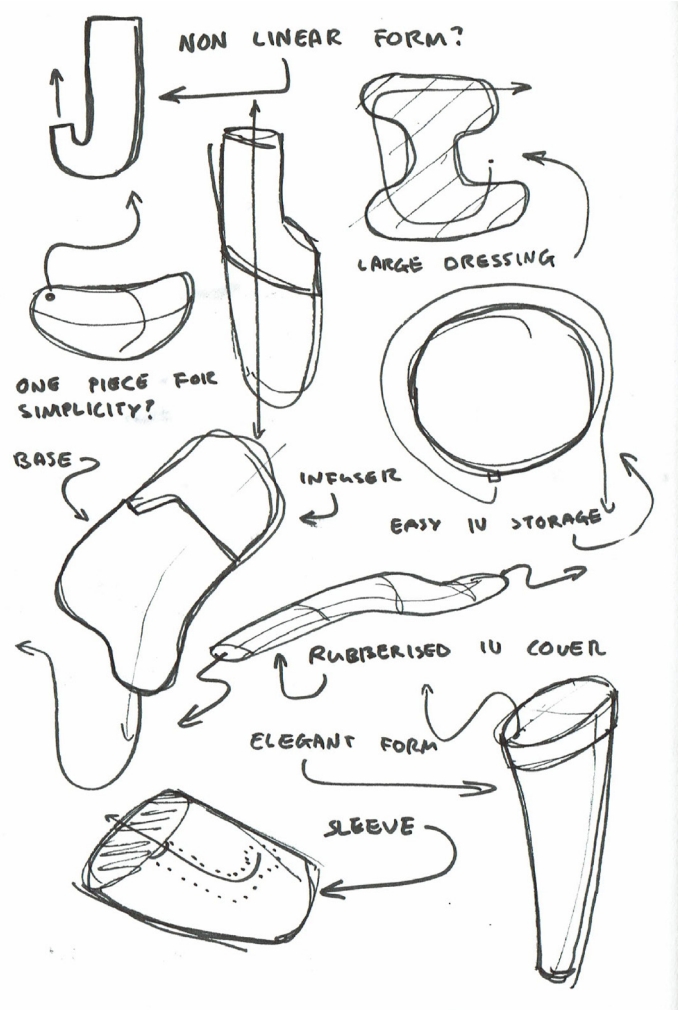
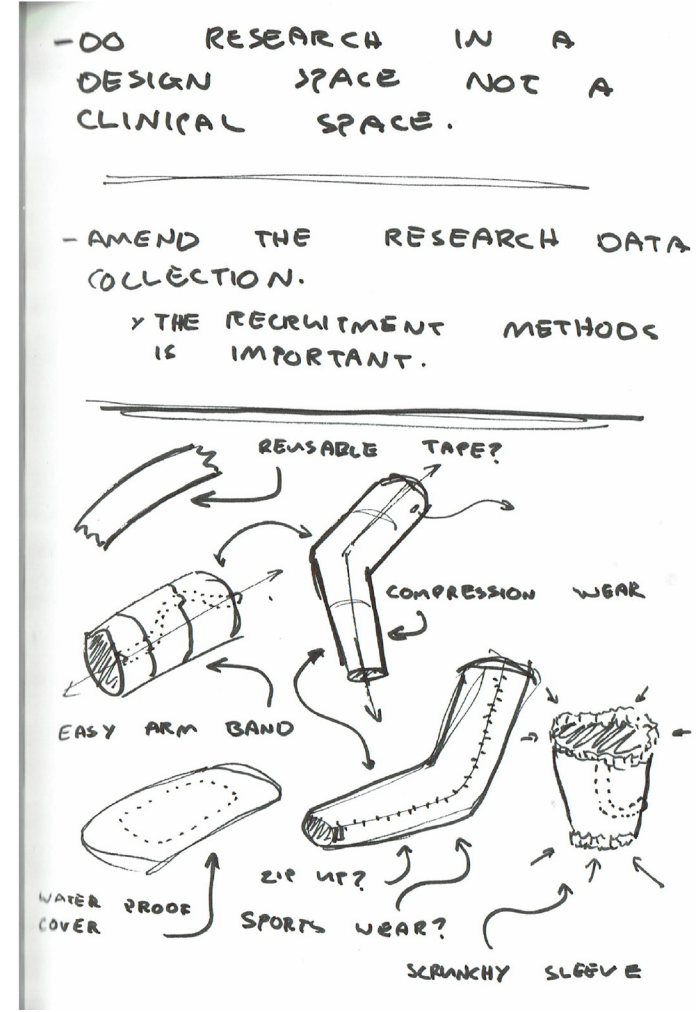
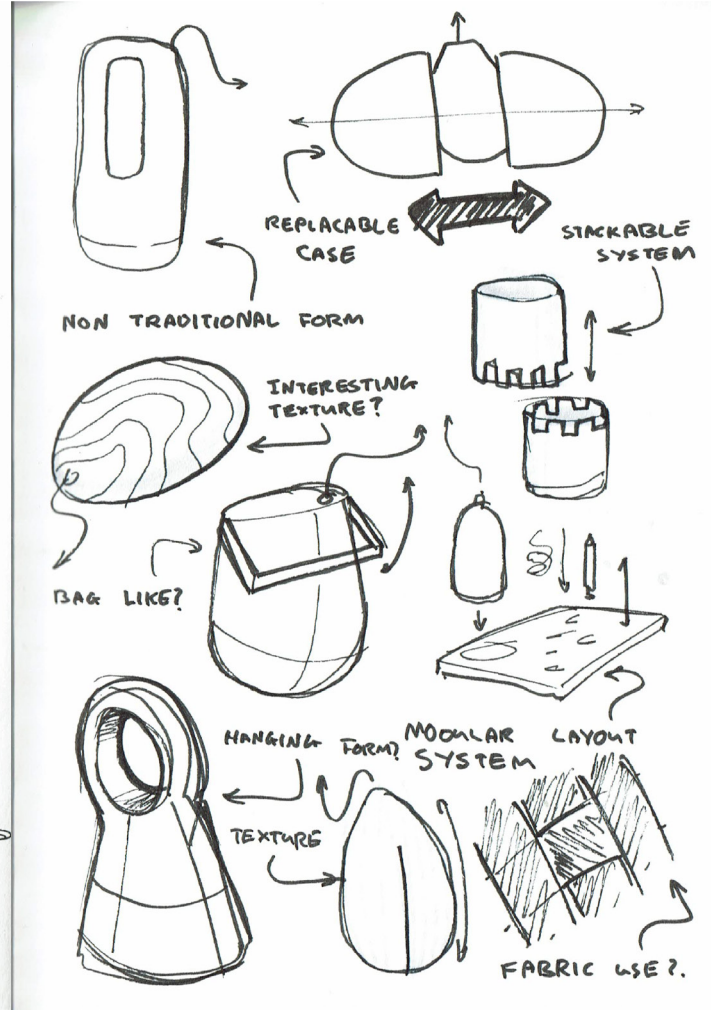
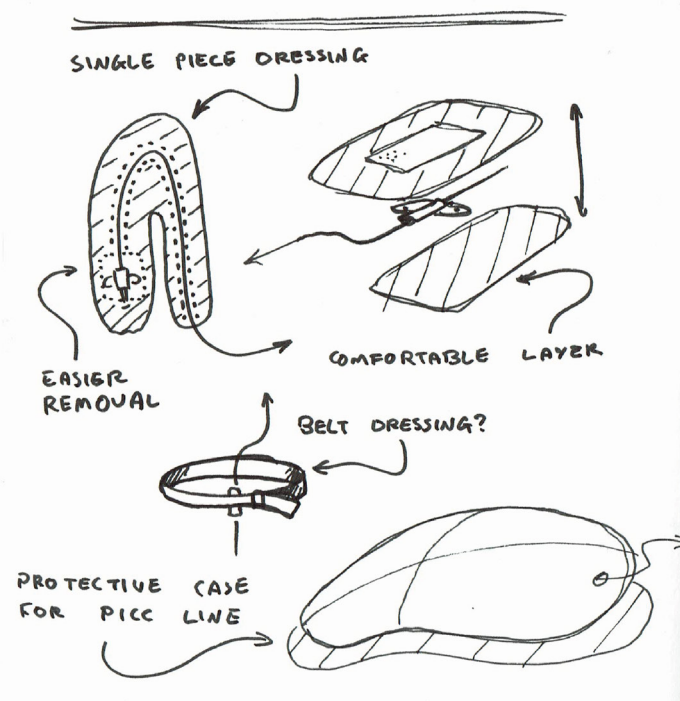
09.2. Appendix B.

Analysis of Discovery Sketches and Mock-ups



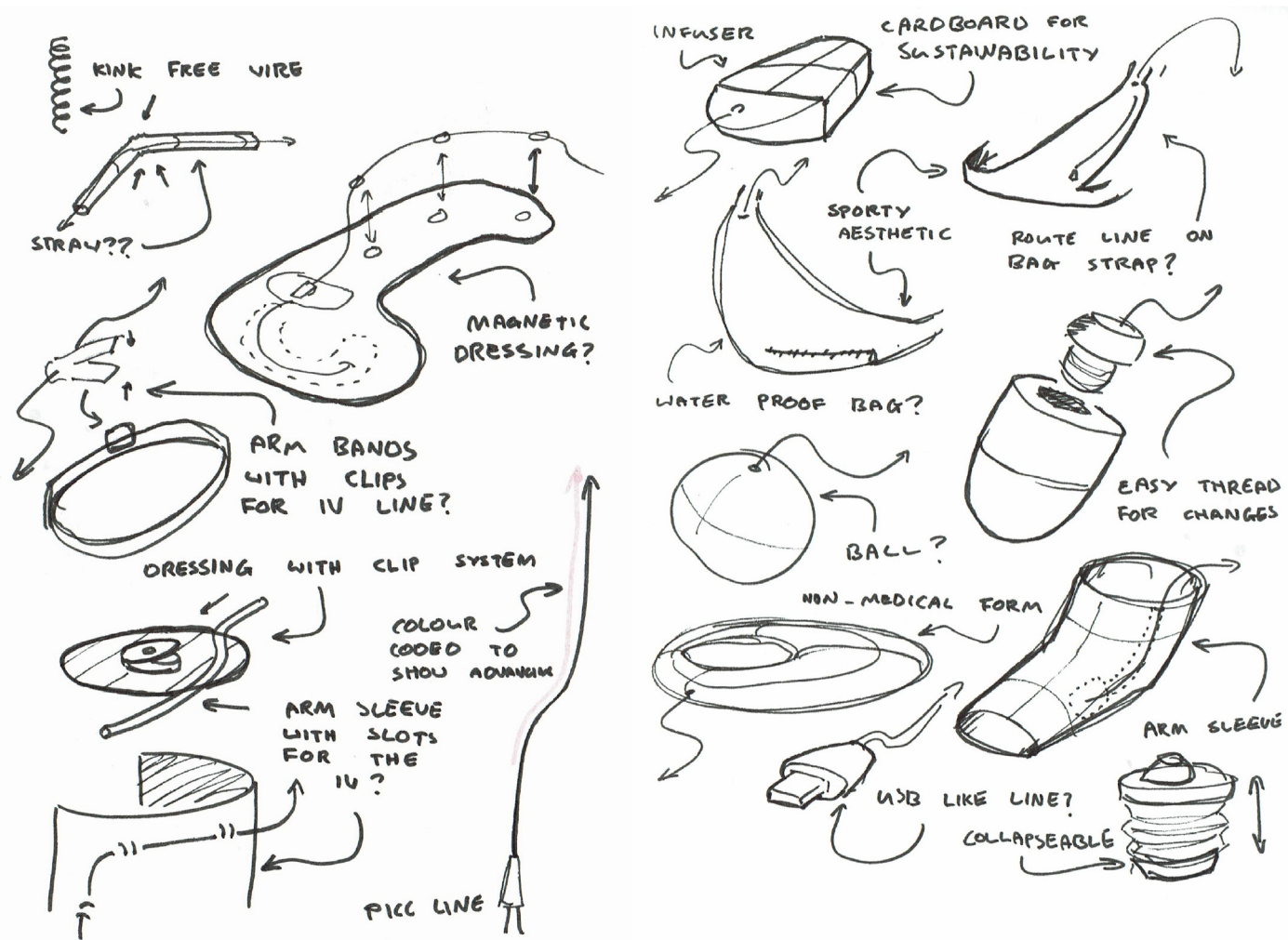
Soft form exploration and storage options for the infuser. The existing infuser produced by Baxter featured a very regularly shaped shell; I wanted to explore if the shape of this shell could be made to fit the body more ergonomically. I felt that this was a key issue with the existing system and decided to further explore ergonomics further in the later stages of the research. Ergonomics in the context of the infuser meant that it would fit more comfortably against the body, considering the shape of the waist (or wherever the infuser could be stored).

2 KEY DESIGN AREAS:
 1. THE DRESSING / 2. THE INFUSER
 3. THE BUM BAG

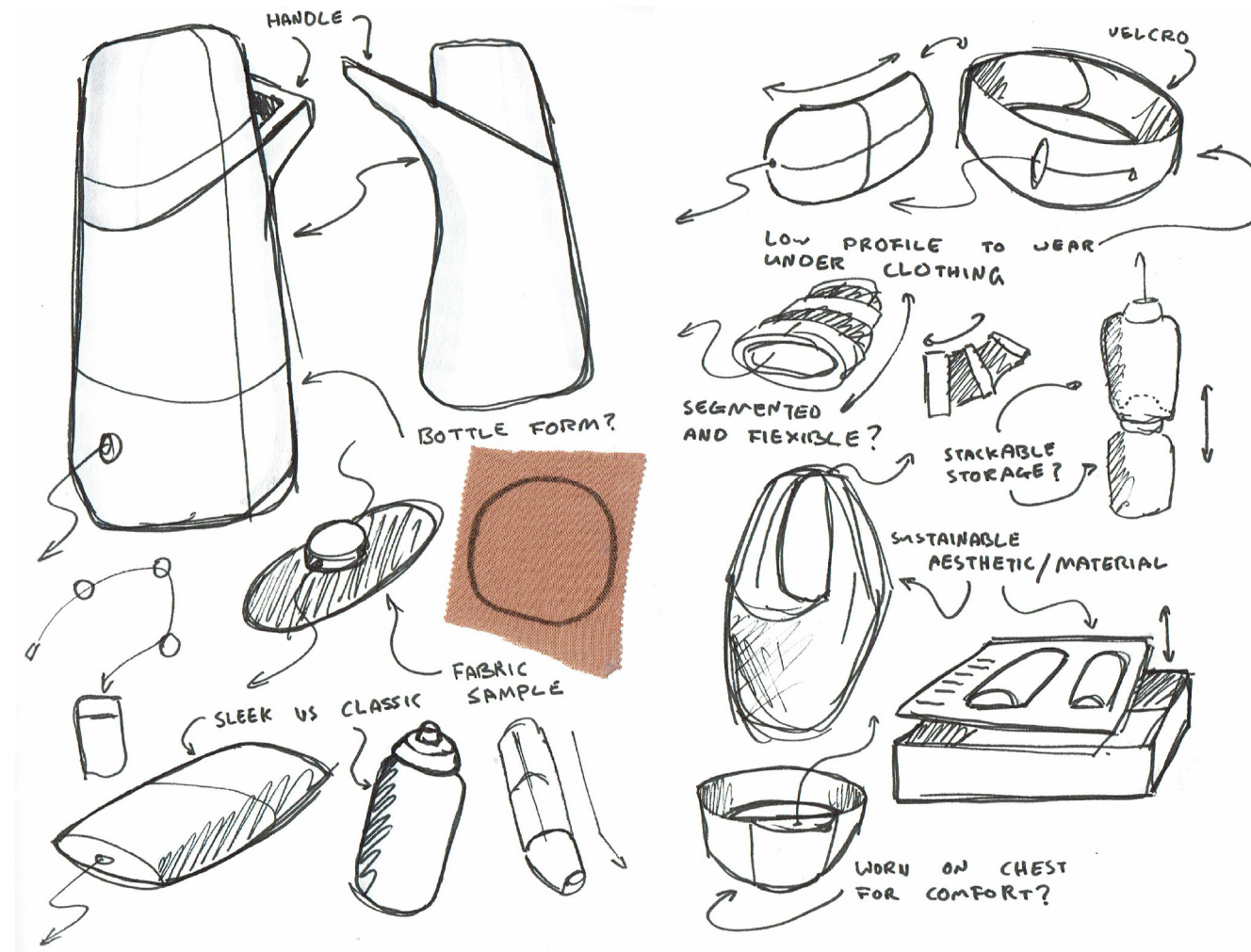


Dressing and IV-line ideation sketches. In the left image, I explored ways to combine the IV line management system with the PICC line dressing and exploring if the infuser could have an adhesive pad to be directly attached to the patient; this would reduce the need for the storage system. The right image of sketches aimed to explore more alternative shapes for the infuser.

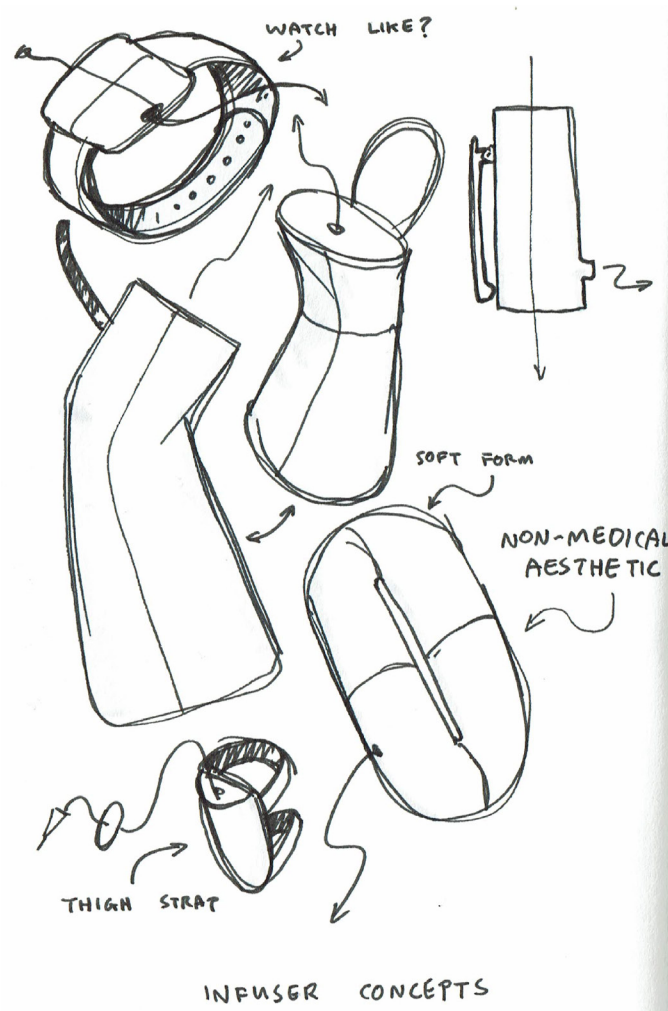
In the left image, I explored if there was an opportunity to combine the IV protection sleeve with the IV line management system. The right image shows my exploration of the form of the infuser and alternative ways of keeping the IV line from being bent and blocked. Although the use of a sleeve had potential, a sleeve could cause overheating in hotter climates.



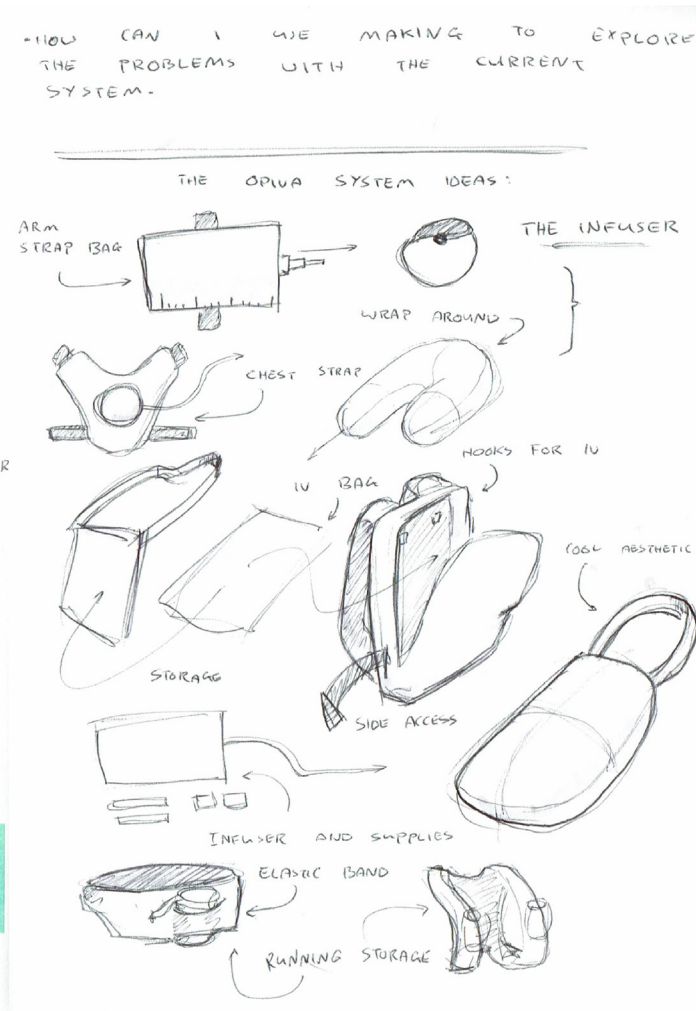
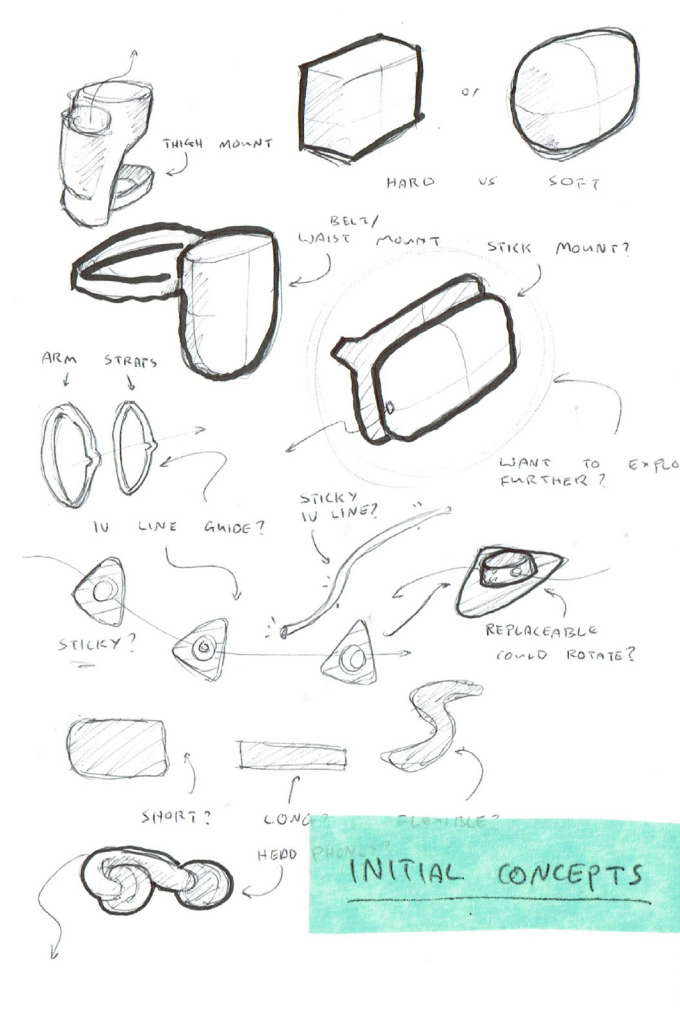
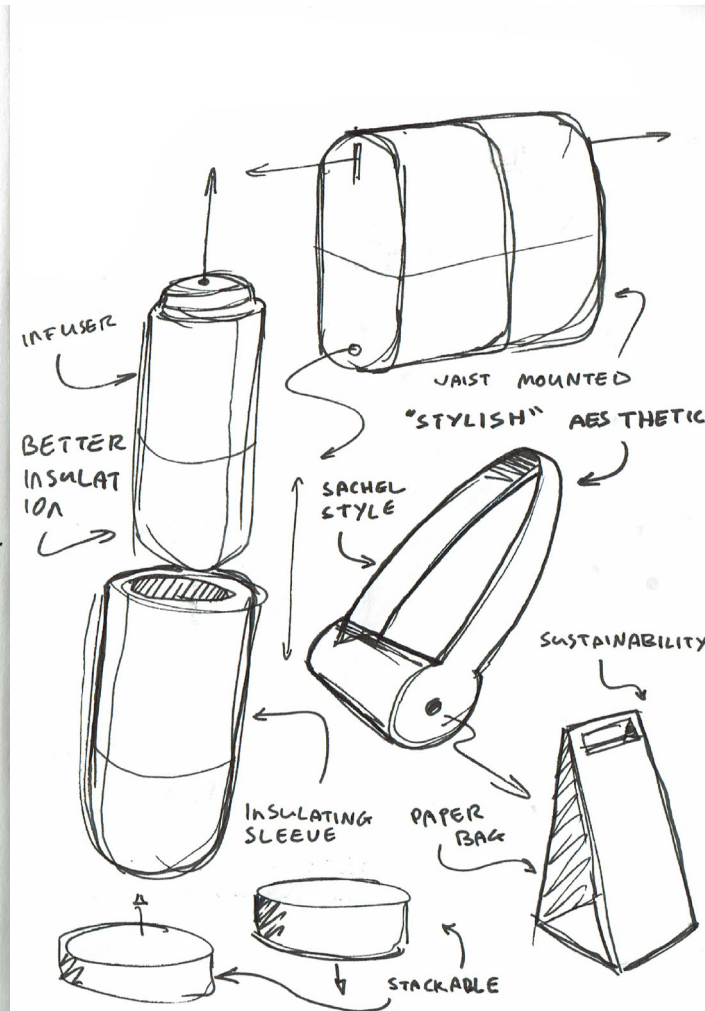
Could magnets be used to solve the IV-line tape issue or a sleeve with a built-in slot? I used these sketches to explore further changes to the shape of the infuser and more alternatives to manage the IV line. The inclusion of magnets or a clip system for the IV line seemed to be the best way to manage the IV line, so I decided to explore this further.



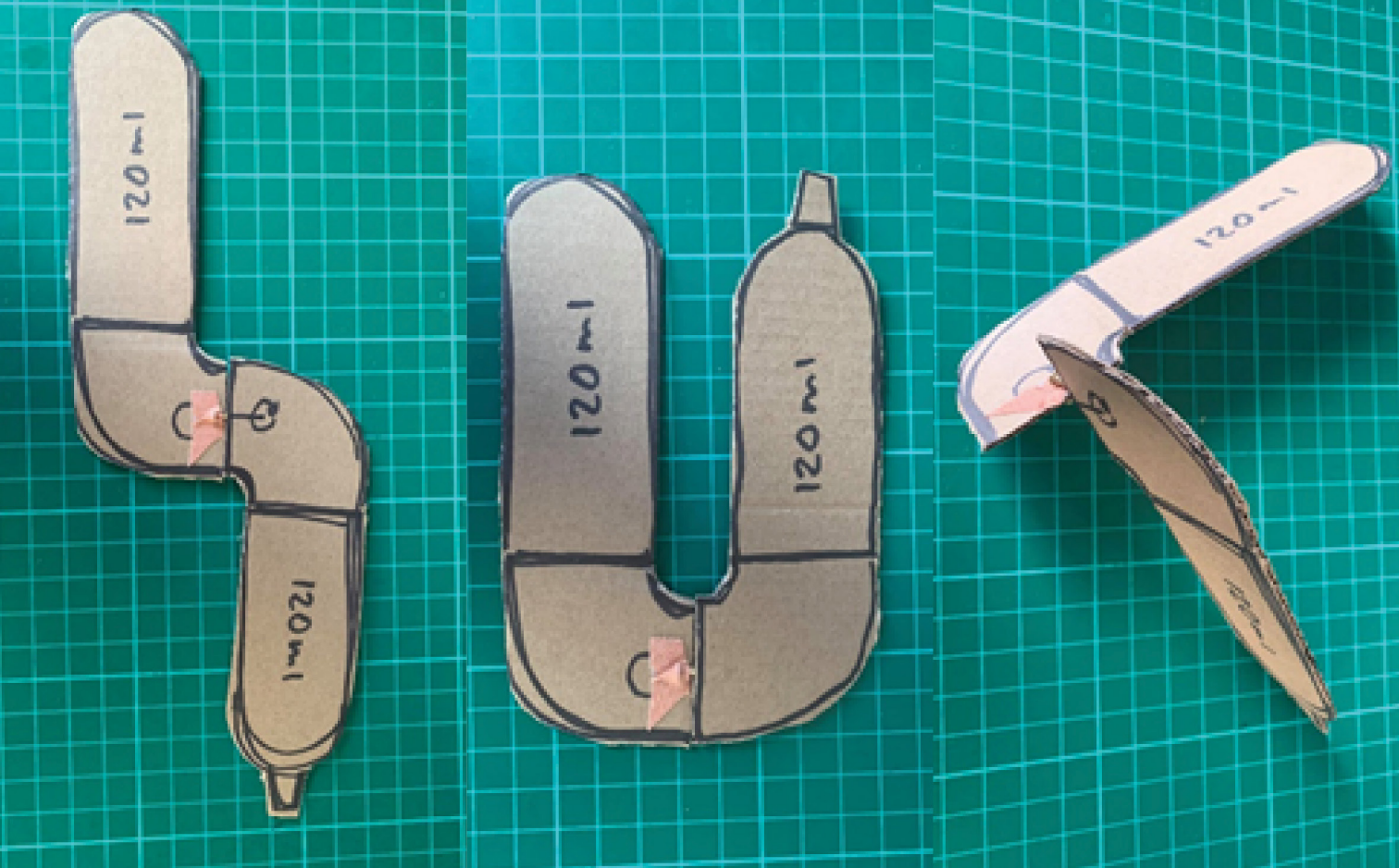
A mix of exploration using patch style dressings for the IV line and different forms for the infuser, and possible packaging for the infusers.



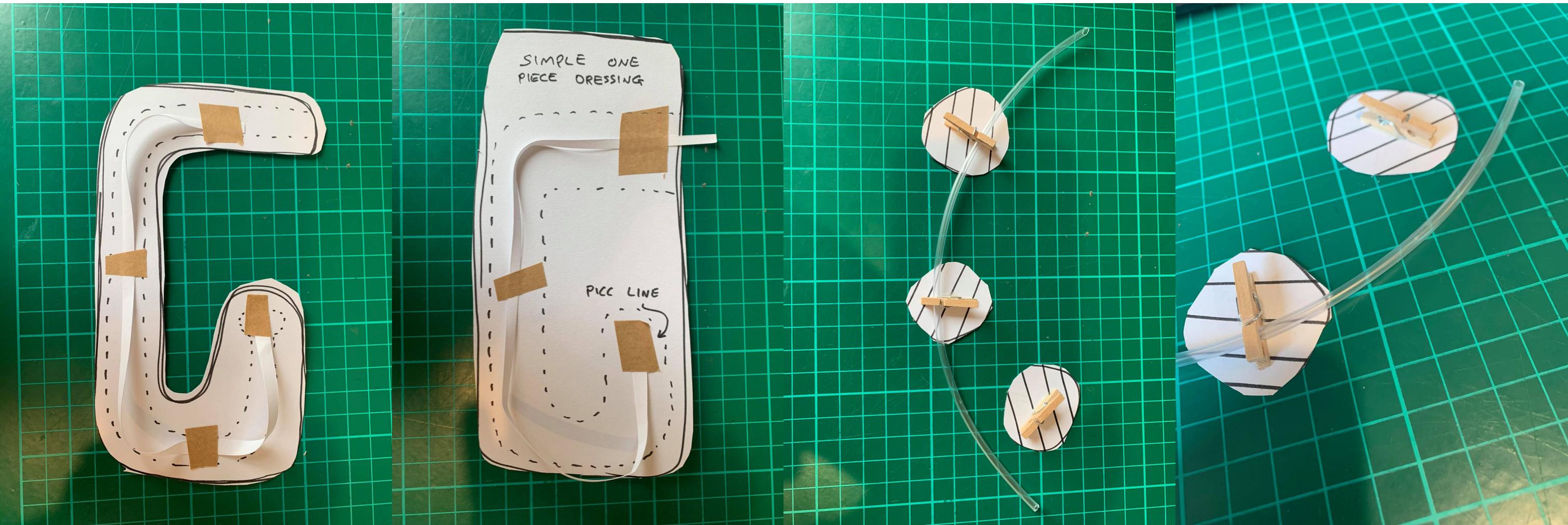
Infuser form ideation. How could the infuser be shaped to solve issues with the existing form? For example, I wanted to see if the infuser could feature a built-in strap or clip to remove the need for the storage system.



Ideation of dressing/taping solutions, storage and IV infuser shape exploration. Building on my earlier sketches, I wanted to see if using a backpack or some other bag to store the infuser was a viable solution for infuser storage rather than the existing waist bag. Although using a backpack to hold the infuser was possible, I felt that it added bulk to the system, which was already an issue. So I decided to focus on trying to explore smaller and less bulky storage solutions.



Exploration of different infuser shapes through rapid prototyping. Cardboard mock-ups were quick to produce and were able to give a sense of scale. Patient participants highlighted that the size and shape of the infuser were awkward to deal with; by changing the shape of the infuser or splitting it into two reservoirs, I attempted to explore a different way to construct the infuser. I felt that although changing the shape of the infuser was valid, splitting it into two pieces added unnecessary complexity to the system.



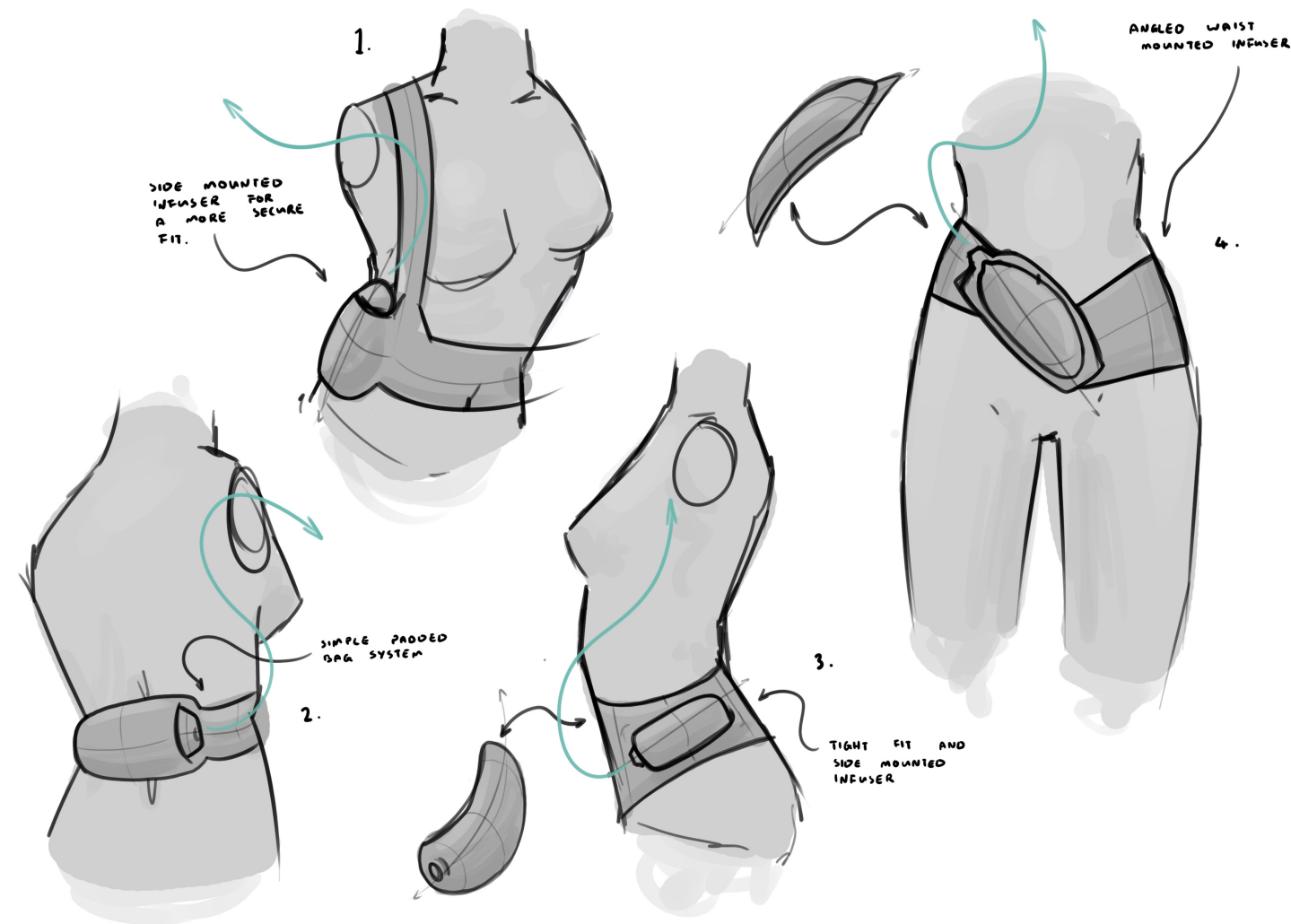
Paper prototypes showing the exploration where I tried routing the IV line through a single large dressing rather than the use of tape. This had potential; however, it would need to be paired up with another IV line management system as simply having a larger dressing will not improve the system's ease of use much if the IV line could not be removed from the dressing. The lack of a PICC line stabilizer also could risk PICC line migration during dressing changes.

I wanted to explore the use of a solution that used a clip system rather than tape to manage the IV line. This was by far the most successful method of managing the IV line. By using built-in clips, I was able to keep the system simple while managing the IV line effectively. I decided to explore the use of clips further in the next ideation stages.

09.3. Appendix C.

Human Factors and Infuser Placement Sketches

Alongside exploring the infuser design, I also decided the infuser storage was just as crucial to the function of the infuser as its shape and aesthetics. Although these sketches went outside my initial focuses of ease of use and non-medical aesthetic, they were still important to consider how the infuser could be placed on the body. After exploring the infuser's design more closely, exploring how it could fit the user and what shape it might be, I quickly realised much of what I was exploring, although interesting, was impractical for actual use. For example, although adding a belt loop to the infuser removed the need for the bag, not every user will want to wear a belt all the time or would have the money to buy a belt. As a result, the next step of the research was to explore the location and placement of the infuser on the patient's body.

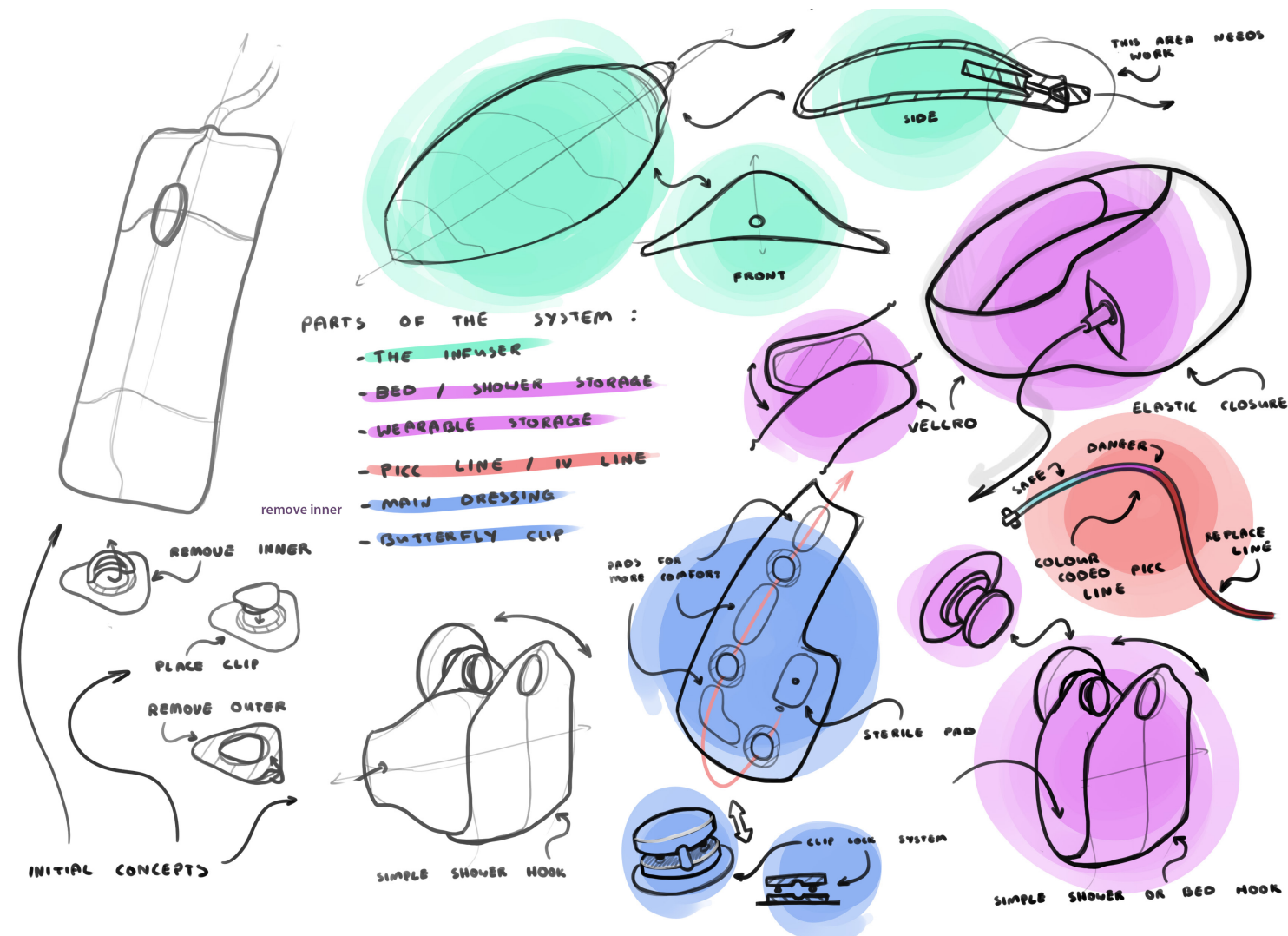


Exploration sketches of the infuser location.

09.4. Appendix D.

First Expert Critique Concept Breakdown

The design featured a one-piece dressing that removed the need for a PICC line stabilization clip and a sterile dressing. This dressing also would provide mounts for simple IV-line clips to allow for easy removal during infuser changes. In addition, the infuser would be stored in a neoprene waist belt which provides insulation for the infuser while remaining more adjustable and fitting more comfortably on the body.

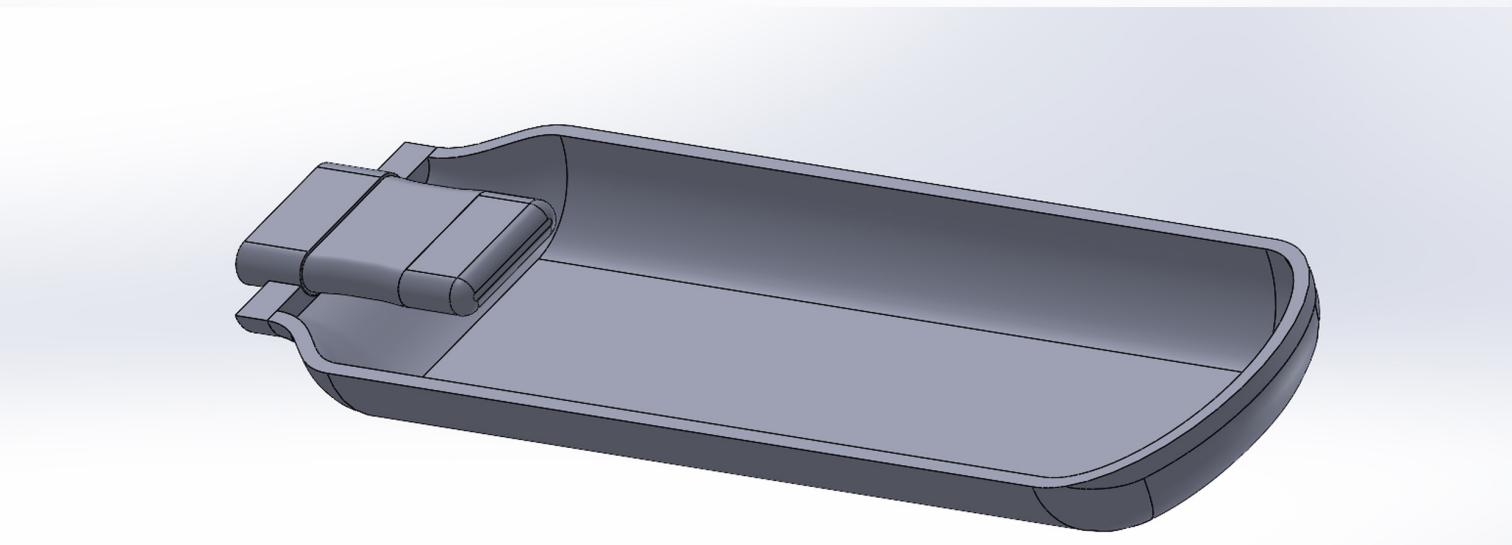
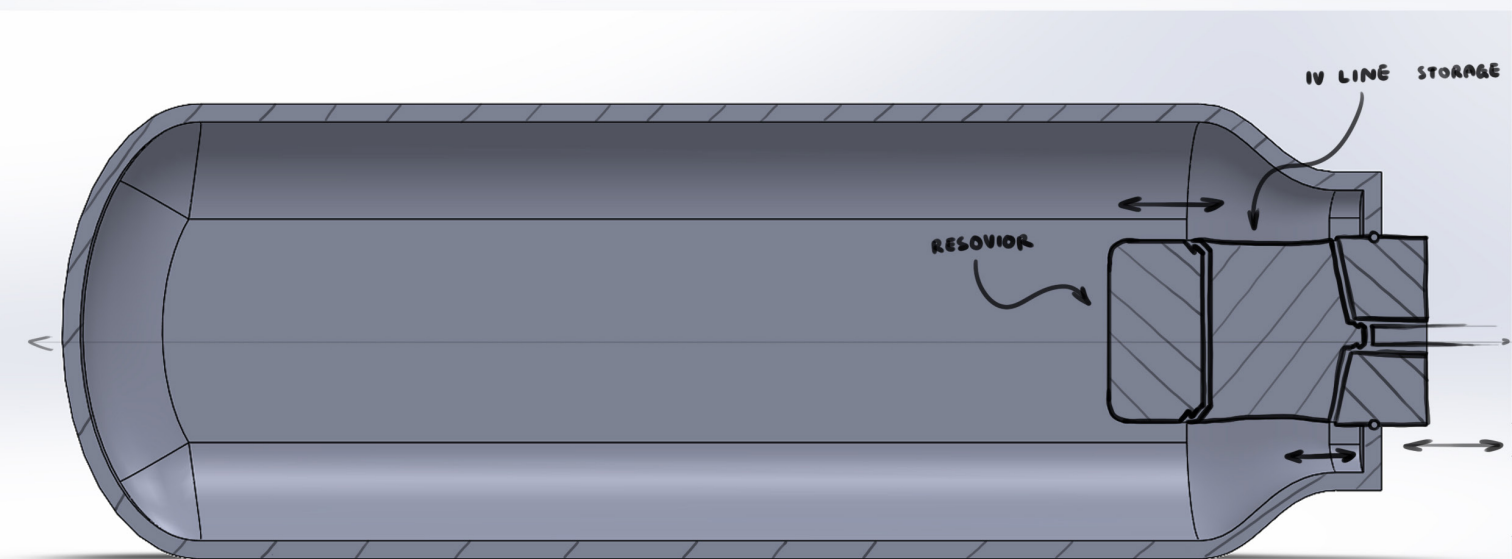
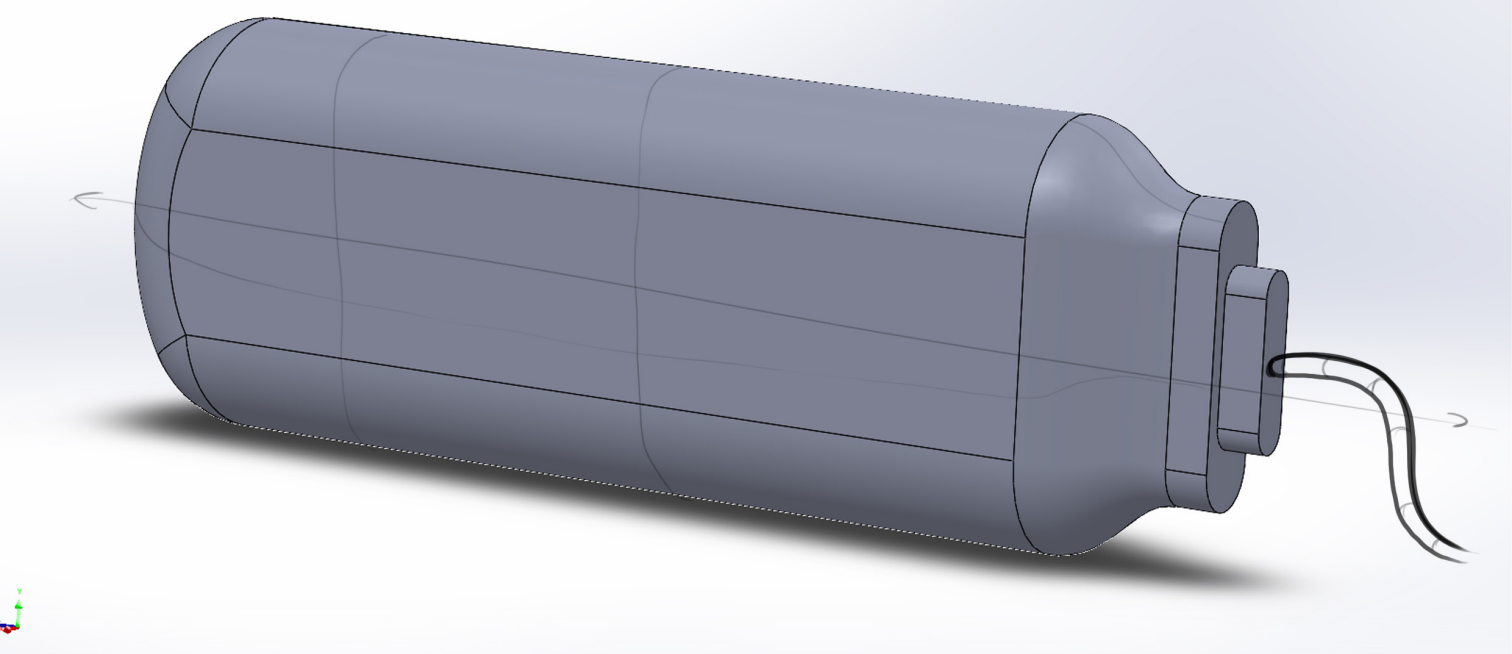


The first design was focused on a system that prioritises ease of use over aesthetics.

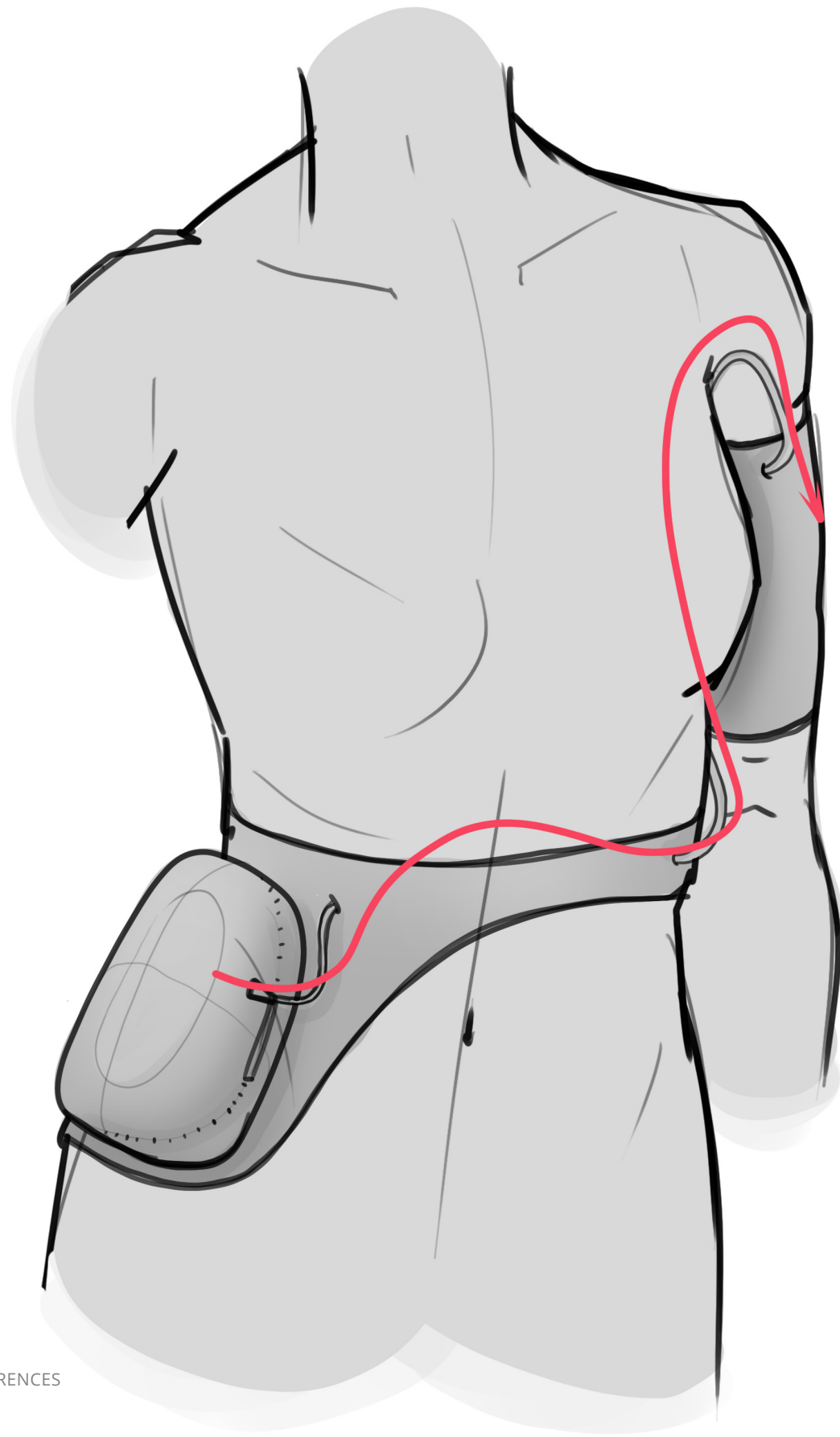


The non-medical aesthetic in this system was achieved by keeping the medical aspects of the design out of sight. Keeping the design elements out of sight was achieved through a side-mounted waist bag for the infuser and a non-slip arm sleeve that can sit over the dressings. The bag could also feature additional storage for infuser changes. This system would also appear more like existing waist bags used in other contexts. The sleeve helped to keep the IV line in place and ensure they were out of sight. In addition, this infuser design had a removal reservoir which the IV line could be wrapped around, again keeping the functional elements of the system out of sight.

The second design direction focused on a non-medical aesthetic.

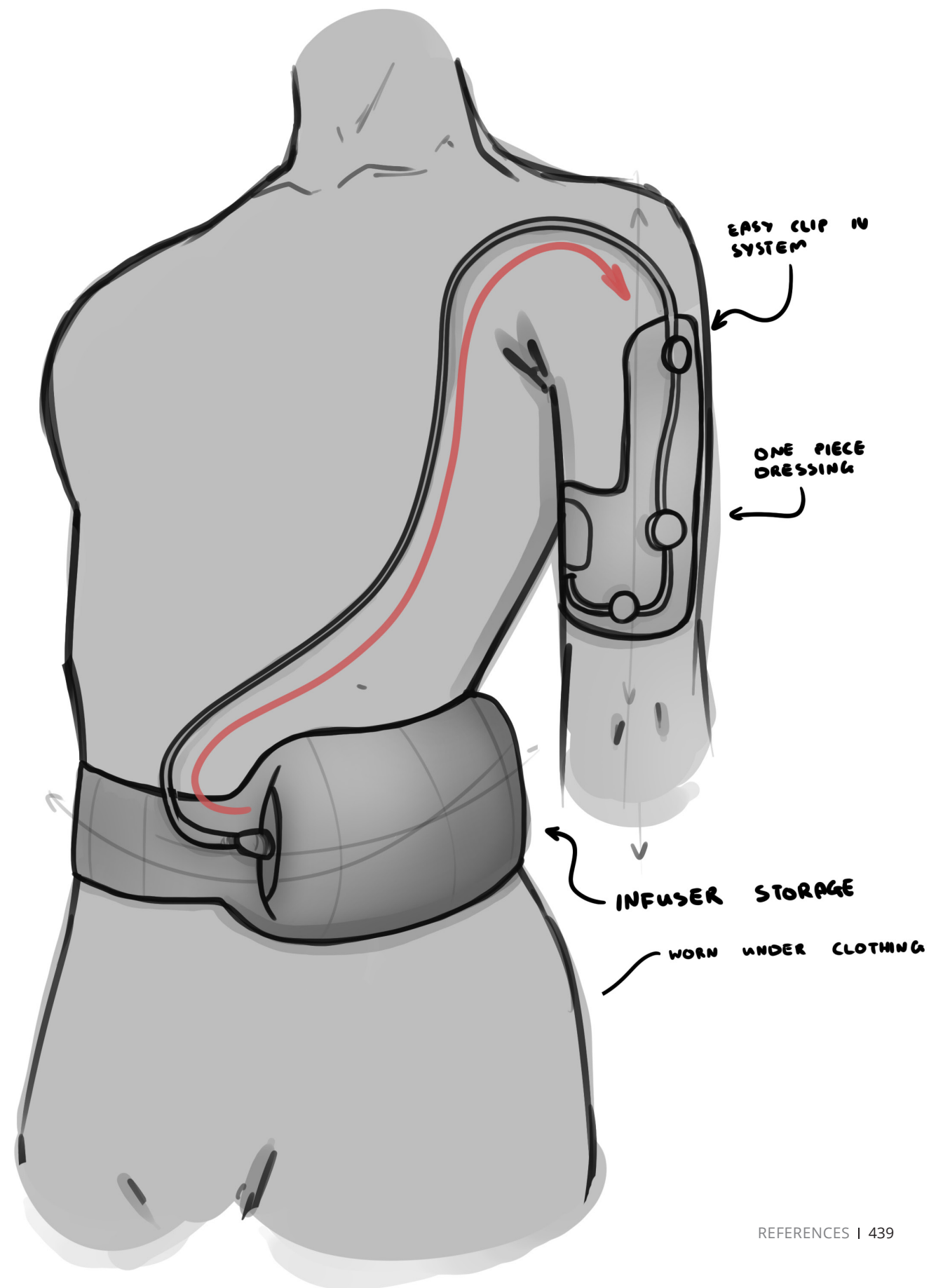


CAD modelling of the non-medical aesthetic infuser concept. Focus on placing the storage for the IV line in an easily removable internal structure. Although this system had possibilities, it was not ergonomic enough in shape, making it difficult to wear comfortably against the body.



After sketching and prototyping, I found that removing the medical aesthetic of the OPIVA system while keeping it functioning within the existing medical systems (an infuser, IV line and PICC line) was very difficult. Without simply hiding parts of the system, it was difficult to achieve a system that does not look medical. This system took cues from existing waist bags and motorcycle side bags.

This design featured the easy removal clip IV line system and a low-profile waist-mounted infuser based on the refined sketches. This infuser was intended to be worn under clothing to impact day to day activities as little as possible.



09.5. Appendix E.

Refined Design Brief - Further Design Considerations

Aesthetics:

As discussed earlier in the research, the appearance and aesthetic of the design were important for the success of the system. Aesthetics for the new system were function-focused while remaining considered and elegant. I decided that minimalism should be a key leading aesthetic in the design as minimalism tends to be considered a modern aesthetic (Baxter, 1995; Syndor & Aileen, 2020). Minimalism as a design aesthetic avoids any visual elements which would detract from the function of the devices and focuses on “elegant simplicity” (Baxter, 1995, p. 41; Obendorf, 2009). Elements should be well designed and appear considered and elegant to show how well thought out the aesthetics of medical devices can be while keeping ergonomics and function as the focus of the system.

Minimal

Simple Soft Forms

Calming Colour Palette

Reliability:

The existing OPIVA system had some issues with reliability, such as infusers breaking in shipping and leaking (Personal Communication OPIVA Nurse Expert Interview, November 30, 2020). The materiality and form of the infusers should be easy to package and ship while remaining robust enough to avoid breakages under normal use. The plastic used in the infuser should not break if dropped from chest height, and the IV-line clips need to

avoid putting stress on the IV line to avoid damage.

Sustainability:

The infuser should be easy to dismantle, and recyclable parts should be clearly labelled. Patients should be aware of which parts of the system can be recycled to avoid unnecessary wastage. The use of recyclable materials should be maximised to ensure the system was sustainable.

Packaging and Delivery:

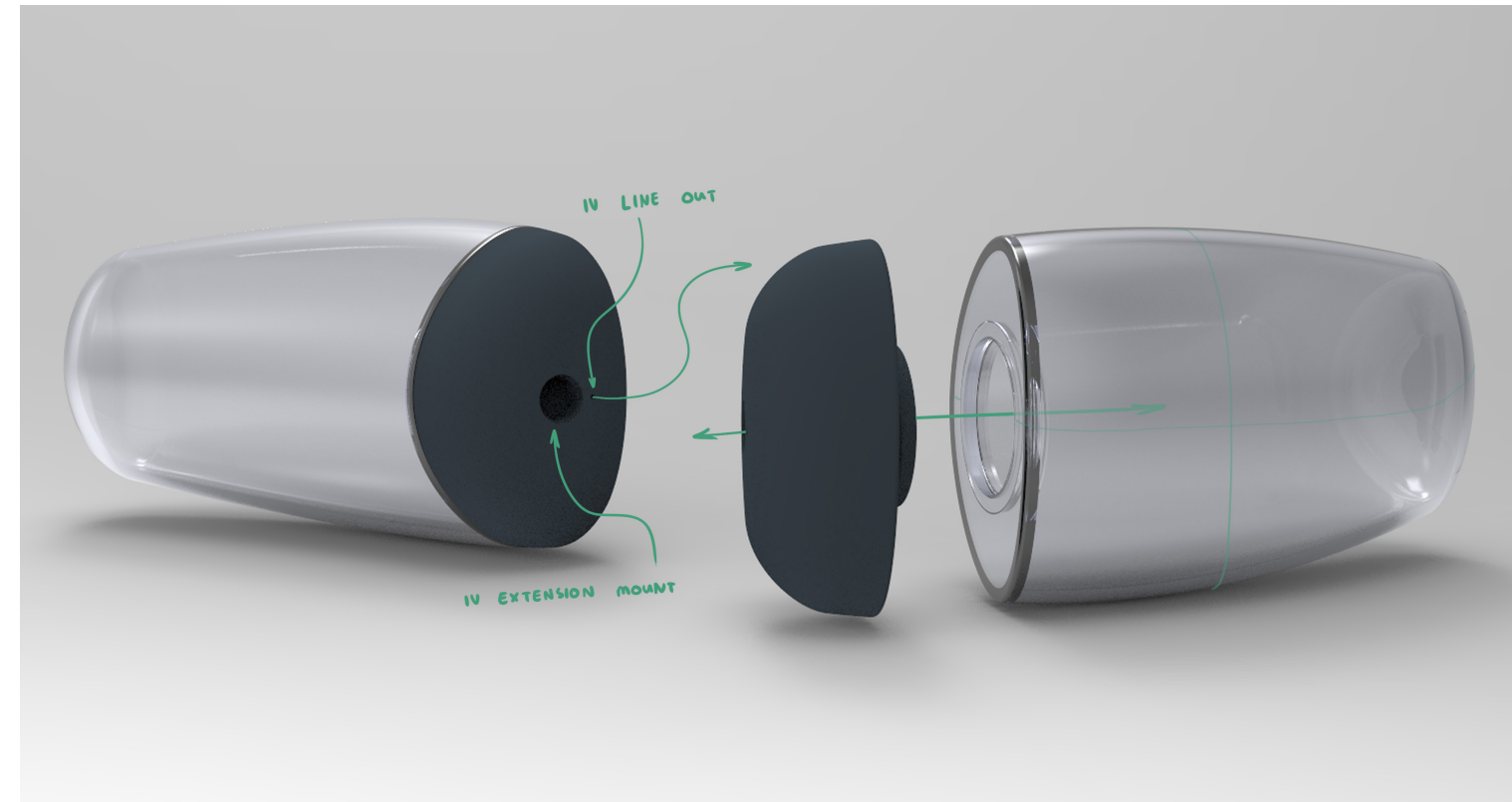
Infusers were delivered in weekly amounts (seven per week) in single shipments. The infusers were currently shipped in a cardboard box with insulated and cooling packaging. The infusers needed to be easy to store and avoid damaging other infusers. This means infusers should be shaped so they can be stored together, taking up minimal space and avoiding materials that could damage each other or the shipping materials. Packing should be cost-effective and store the infusers while maximising sustainable material use and avoiding waste where possible.

Cost:

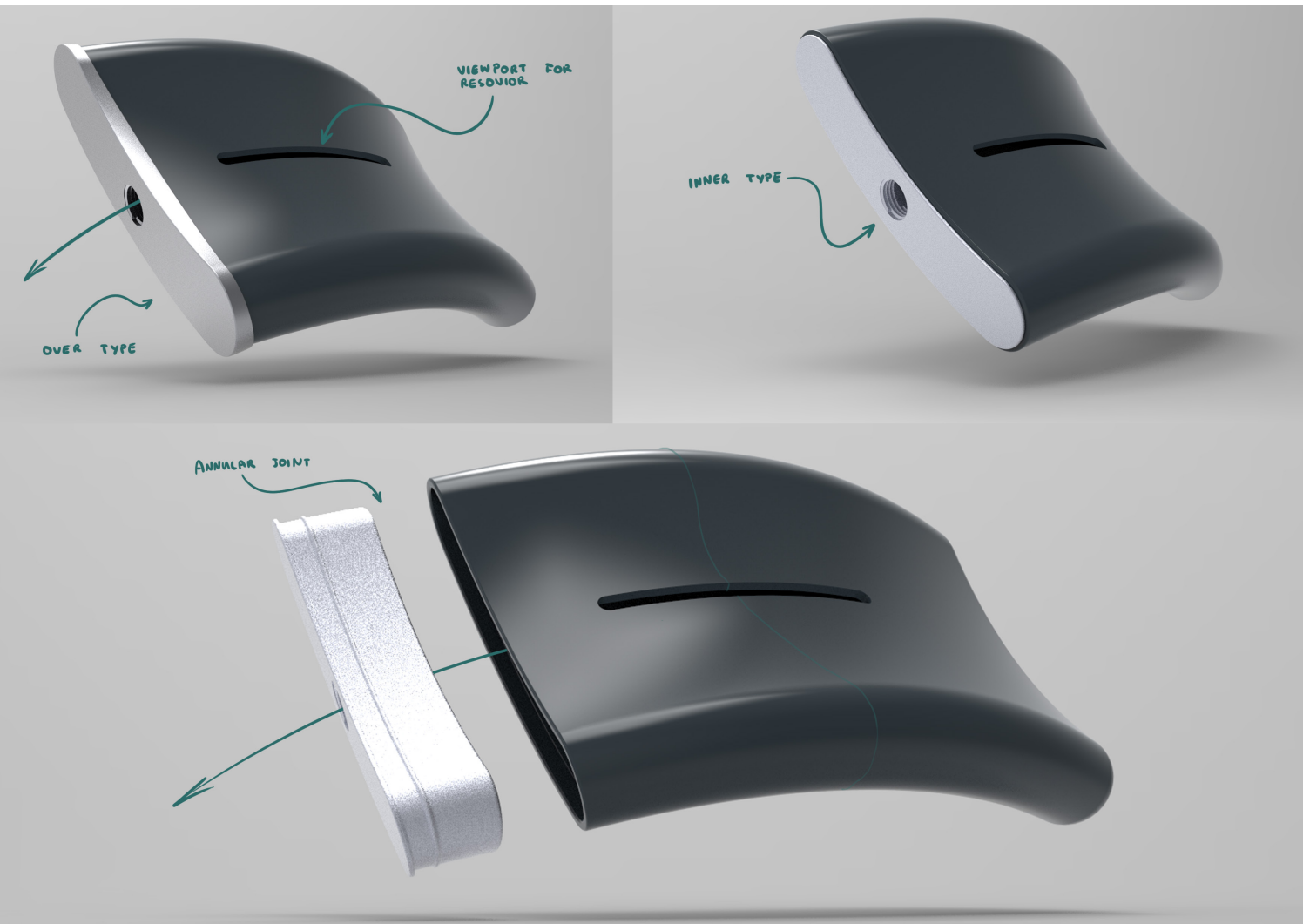
The OPIVA system of devices needed to be cheap enough to dispose of, and therefore, cost should be kept to a minimum. Patient’s will only be in the OPIVA service for around six to eight weeks meaning high cost or high perceived value would not benefit the patient. Cost should be kept as low as possible without sacrificing the quality or reliability of the system.

09.6. Appendix F.

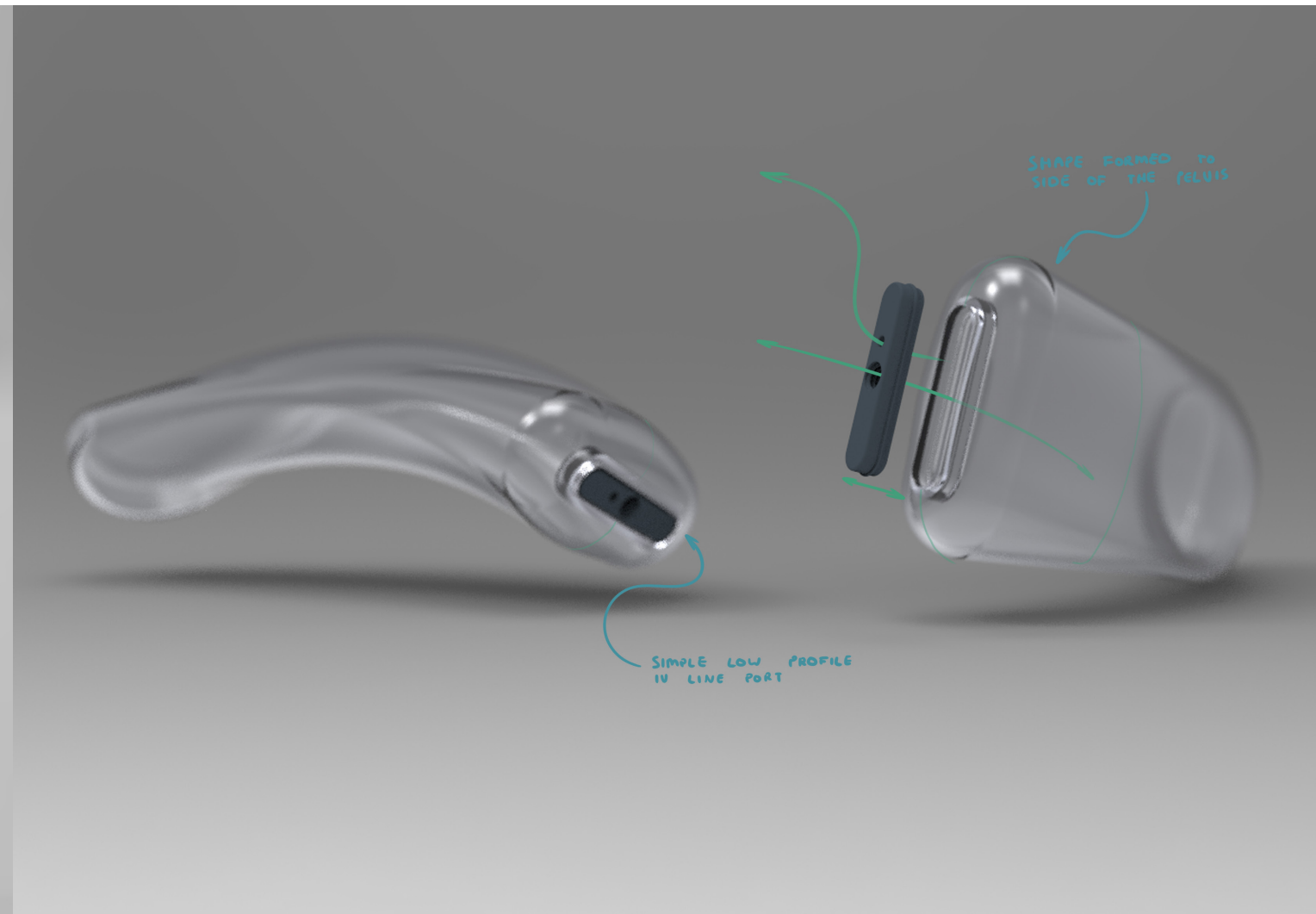
Detailed Explanations of Each Refocused Infuser CAD Model



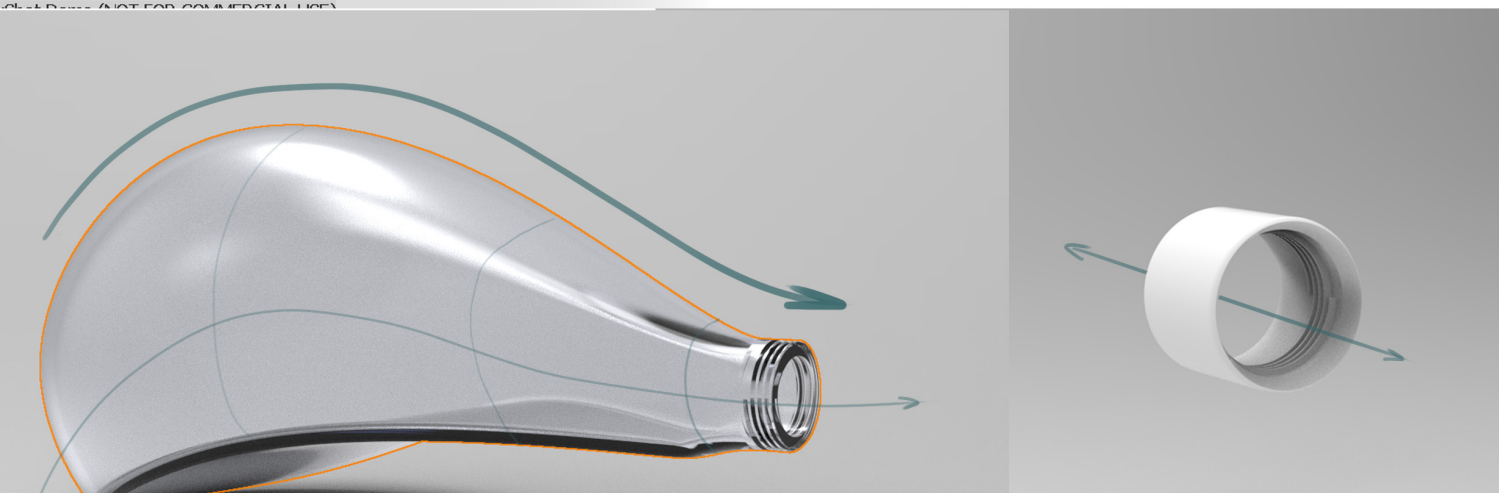
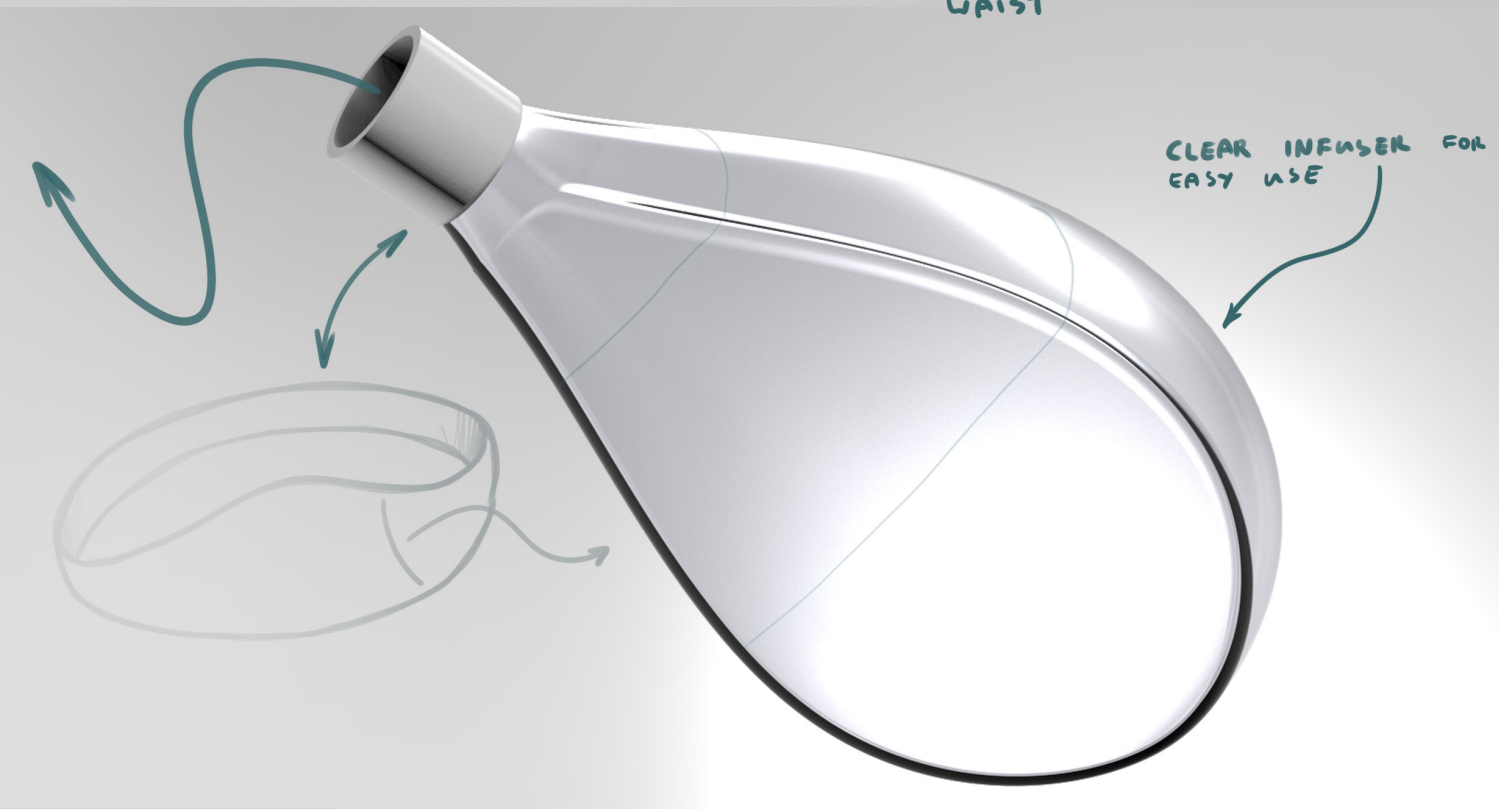
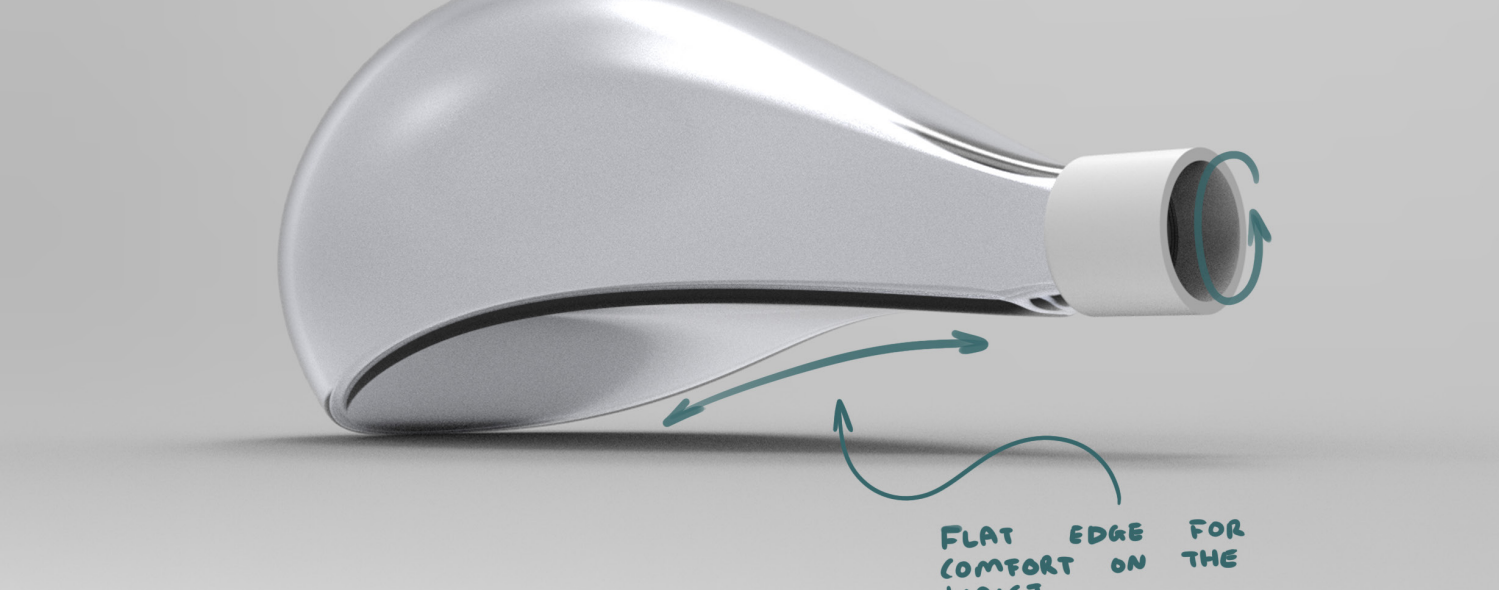
The 'Bean' Infuser CAD model. The 'Bean' infuser concept featured a combined concave and convex curve that aimed to fit comfortably around the user's upper waist. The design featured a larger cap that used an annular joint.



The 'Bento' Infuser, exploring cap styles for the infusion line. The infuser cap needed to be easy to remove to ensure easy recycling while remaining solid enough to avoid accidental removal during use and risking damage to the infuser. Similarly to most of these initial CAD models, this design featured an annular joint.



The 'Squash' Infuser. Like the 'Bean' infuser, this concept aimed to best fit on the user's hips. As a result, this design focused on a specific placement rather than being easily rotated on the body. By using a multi-directional curve, the design was intended to sit comfortably on the user's side rather than the front of their abdomen.

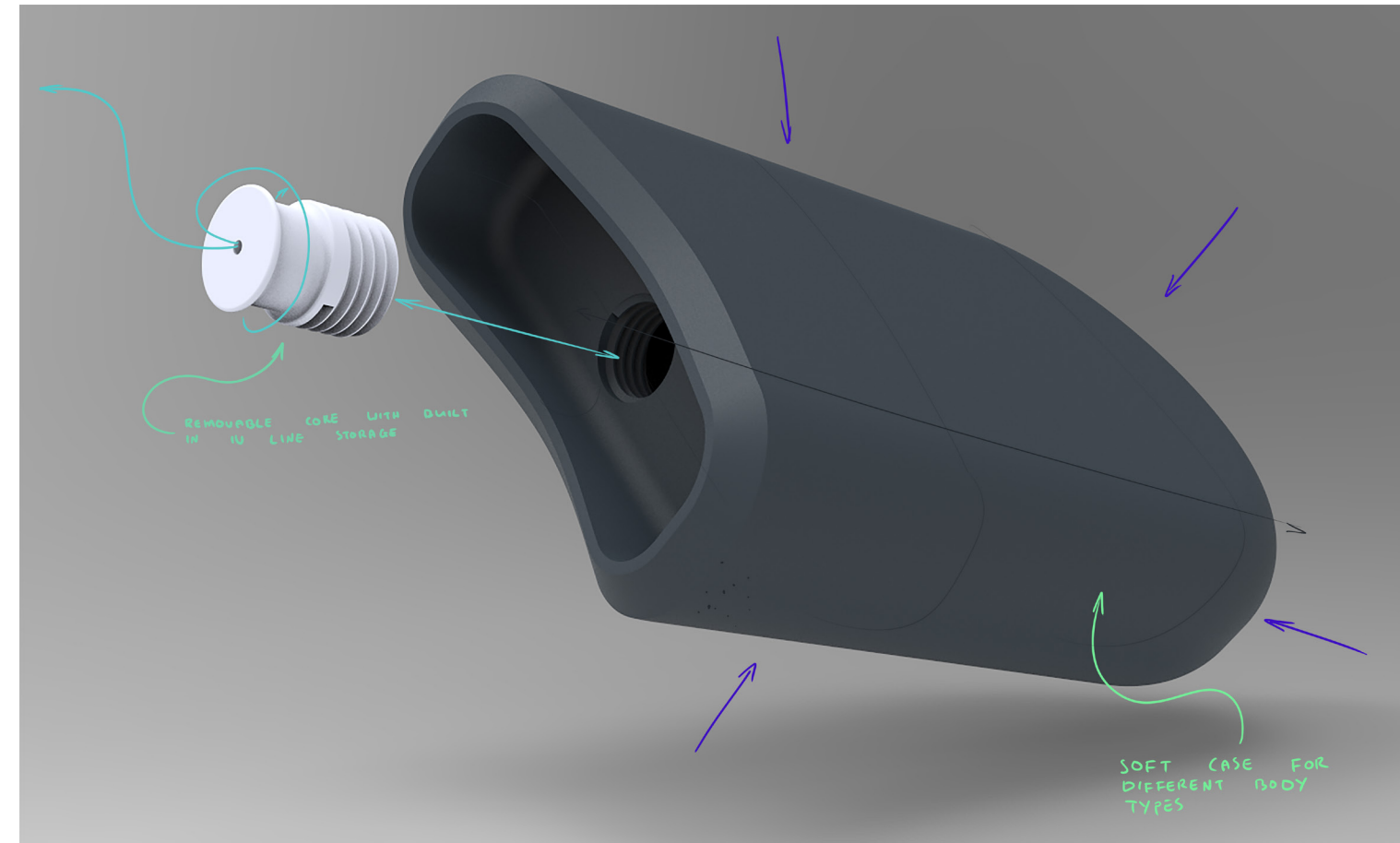


The 'Pear' Infuser. Rather than a press-fit cap, the 'Pear' featured a threaded cap to allow for easier removal following use. This concept also featured a shell that extended further from the body, allowing for a smaller contact patch on the skin.

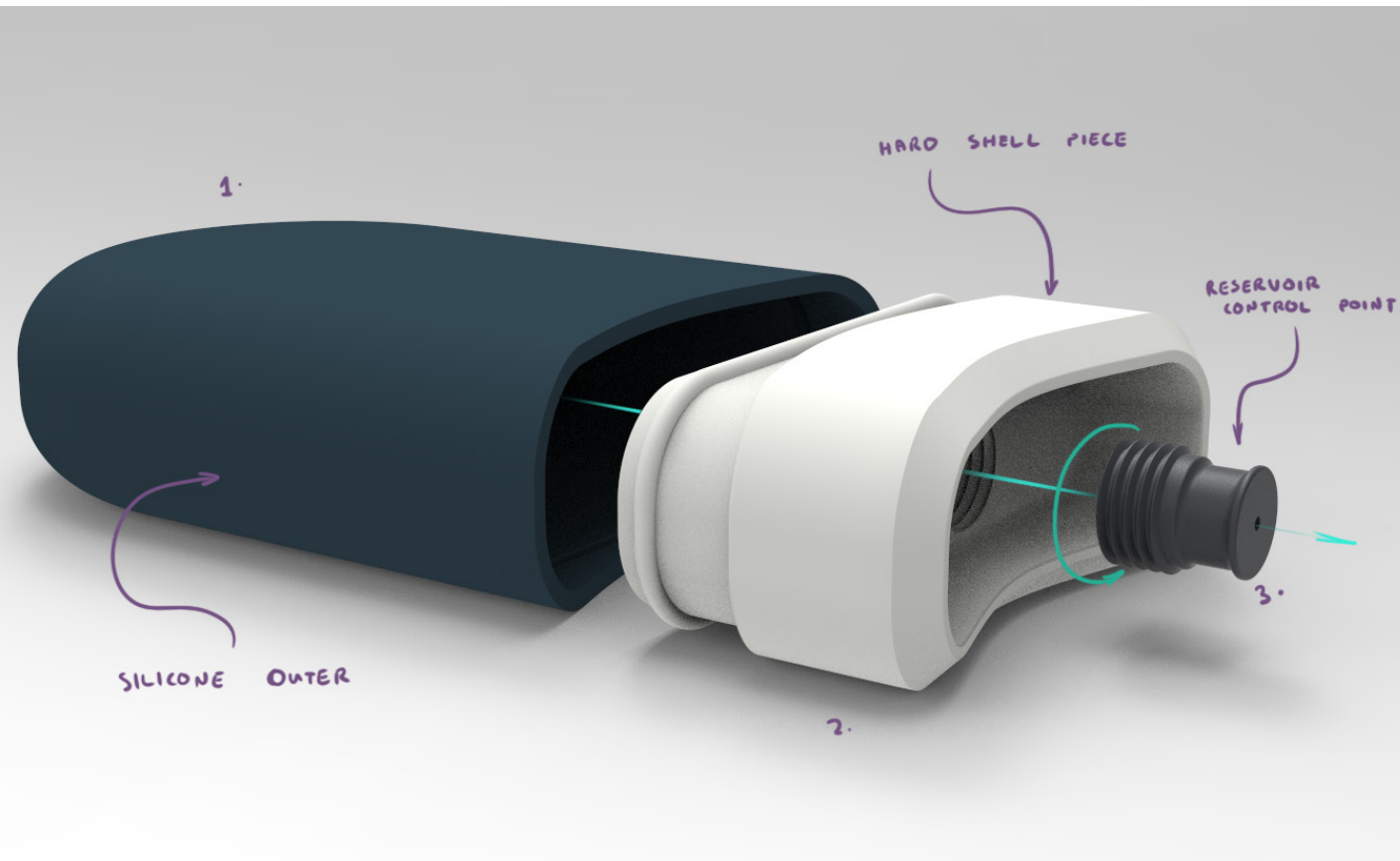
09.7. Appendix G.

Soft Shell Infuser Reflections

Although I set out to work within the existing constraints of the Baxter infuser, which featured a hard shell, I still wanted to explore if a soft-shell infuser was a significant improvement on the existing infuser. Therefore, I explored the use of silicone for the infuser shell.



A soft-shell, silicone-based infuser concept. The inclusion of a silicone reservoir could allow for a more individual fit. However, threading the IV-line control point into this creates a loose fit and did not hold the IV out securely. The silicone could be glued; however, in the research brief, I set out to create a system that could be dismantled easily and any parts which were glued would reduce this.



The refined soft-shell infuser concept.

The second version of this infuser concept featured a soft-shell and a hard-shell base. This design meant that the IV outlet would be more securely mounted to avoid any risks of damage to the reservoir during use. The silicone also made up less of the design, meaning more of the device could be recycled (Gosh et al., 2003).

There were issues with the robustness and durability of the soft-shell infuser. I felt that creating a robust system using silicone would have been too difficult to overcome without a complex system of joining the parts together. The silicone could be glued in place, but recycling plants will often not recycle multi-material plastic products due to the difficulty of separating these (Hopewell, 2009).



Silicone moulding was tested for the soft-shell infuser; however, getting the silicone robust enough without glue became too complex to be viable quickly.

09.8. Appendix H.

Ethics Application 20/293

Auckland University of Technology Ethics Committee (AUTEC)

Auckland University of Technology
D-88, Private Bag 92006, Auckland 1142, NZ
T: +64 9 921 9999 ext. 8316
E: ethics@aut.ac.nz
www.aut.ac.nz/researchethics

6 October 2020

Stephen Reay
Faculty of Design and Creative Technologies

Dear Stephen

Re Ethics Application: **20/293 Improving patient experiences with OPIVA through human-centred product design**

Thank you for providing evidence as requested, which satisfies the points raised by the Auckland University of Technology Ethics Committee (AUTEC).

Your ethics application has been approved for three years until 6 October 2023.

Standard Conditions of Approval

1. The research is to be undertaken in accordance with the [Auckland University of Technology Code of Conduct for Research](#) and as approved by AUTEC in this application.
2. A progress report is due annually on the anniversary of the approval date, using the EA2 form.
3. A final report is due at the expiration of the approval period, or, upon completion of project, using the EA3 form.
4. Any amendments to the project must be approved by AUTEC prior to being implemented. Amendments can be requested using the EA2 form.
5. Any serious or unexpected adverse events must be reported to AUTEC Secretariat as a matter of priority.
6. Any unforeseen events that might affect continued ethical acceptability of the project should also be reported to the AUTEC Secretariat as a matter of priority.
7. It is your responsibility to ensure that the spelling and grammar of documents being provided to participants or external organisations is of a high standard and that all the dates on the documents are updated.

AUTEC grants ethical approval only. You are responsible for obtaining management approval for access for your research from any institution or organisation at which your research is being conducted and you need to meet all ethical, legal, public health, and locality obligations or requirements for the jurisdictions in which the research is being undertaken.

Please quote the application number and title on all future correspondence related to this project.

For any enquiries please contact ethics@aut.ac.nz. The forms mentioned above are available online through <http://www.aut.ac.nz/research/researchethics>

(This is a computer-generated letter for which no signature is required)

The AUTEC Secretariat
Auckland University of Technology Ethics Committee

Cc: Kate.weatherly@aut.ac.nz

Auckland University of Technology Ethics Committee (AUTEC)

Auckland University of Technology
D-88, Private Bag 92006, Auckland 1142, NZ
T: +64 9 921 9999 ext. 8316
E: ethics@aut.ac.nz
www.aut.ac.nz/researchethics

4 November 2020

Stephen Reay
Faculty of Design and Creative Technologies

Dear Stephen

Re: Ethics Application: **20/293 Improving patient experiences with OPIVA through human-centred product design**

Thank you for your request for approval of amendments to your ethics application.

The amendment to the inclusion criteria (previous patients of the OPIVA service within the Waitemata DHB has been approved.

1. Remove bullet points 4 and 9 from the Consent Form as they apply to the single case study only.
2. Remove from the phone call script the following sentence 'Attached is a Participant Information Sheet giving further detail of the study'

Non-standard conditions must be completed before commencing your study. Non-standard conditions do not need to be reviewed by AUTEC before commencing your study but please forward updated documents for our file.

I remind you of the **Standard Conditions of Approval**.

1. The research is to be undertaken in accordance with the [Auckland University of Technology Code of Conduct for Research](#) and as approved by AUTEC in this application.
2. A progress report is due annually on the anniversary of the approval date, using the EA2 form.
3. A final report is due at the expiration of the approval period, or, upon completion of project, using the EA3 form.
4. Any amendments to the project must be approved by AUTEC prior to being implemented. Amendments can be requested using the EA2 form.
5. Any serious or unexpected adverse events must be reported to AUTEC Secretariat as a matter of priority.
6. Any unforeseen events that might affect continued ethical acceptability of the project should also be reported to the AUTEC Secretariat as a matter of priority.
7. It is your responsibility to ensure that the spelling and grammar of documents being provided to participants or external organisations is of a high standard.

AUTEC grants ethical approval only. You are responsible for obtaining management approval for access for your research from any institution or organisation at which your research is being conducted. When the research is undertaken outside New Zealand, you need to meet all ethical, legal, and locality obligations or requirements for those jurisdictions.

Please quote the application number and title on all future correspondence related to this project.

For any enquiries please contact ethics@aut.ac.nz. The forms mentioned above are available online through <http://www.aut.ac.nz/research/researchethics>

(This is a computer-generated letter for which no signature is required)

The AUTEC Secretariat
Auckland University of Technology Ethics Committee

Cc: Kate.weatherly@aut.ac.nz

Kate Weatherly