

Feasibility Study to Install a 1 MW Grid Connected Solar Plant in Wairoa-Mahia Peninsular, New Zealand

A. Garae Liu, T. T. Lie

Department of Electrical & Electronic Engineering, Auckland University of Technology, Auckland, New Zealand
(e-mail: tek.lie@aut.ac.nz)

Abstract - This study intends to investigate the voltage drop issue along the Mahia distribution network (11kV line) and further assess the feasibility of developing a grid tied 1MW solar farm in Wairoa District, New Zealand. The objective is to provide the solution for Wairoa's local distribution Company to mitigate Voltage drops and increasing summer load demand arising due to the influx of visitors (est. spike of 800 to 3-5000 visitor's over a 2-week period) to Mahia Peninsular. Furthermore, a solution to avoid transmission charges, increase supply security, reducing peak load demand and aim at substituting the non-environmental friendly operated 1MW diesel generator in Mahia.

Keywords - Photovoltaic (PV), Voltage Drop, Distribution network

I. INTRODUCTION

Traditional Electrical Power systems over the past years have evolved drastically to meet the increasing growth in demand for electricity access and to accommodate for the changes in technology to improve the robustness and conveniences of the overall power systems. Obviously it has been predominantly dominated by Fossil fuels base generation until the 21st century when the way energy or electricity is produced and distributed has transformed into cleaner and newer technologies like Renewable energies (RE) such as Hydro, Geothermal, Wind and Solar energy technology. Through the advancement of technology improvement (control systems) and improved regulatory environment, coordinated operating and planned procedures have made possible the connection of local and regional networks into large interconnected network to satisfy the growing access and distant peak demands [1].

Accordingly, this research builds its focus particularly around the distributive layer of New Zealand's (NZ) Power system aiming at investigating technical solutions to a Distributed Power Network at the East Coast of New Zealand's North Island, of which currently are experiencing technical issues relating to Voltage Drop (VD) and Load Demand (LD) shortfall over the 11kV distribution lines. Most specifically the core aim is to investigate the potential of Solar PV based Distributed Generation (DG) system to substitute the existing diesel-based DG at Mahia area (Wairoa District) which currently offers mitigating solutions to the above-mentioned technical issues.

In brief, NZ electricity power market employs an unbundling structure whereby the entire power system is not managed and operated by a single monopolized Utility, but rather a bunch of Generation, Distribution and Retail Companies, leaving only Transpower Ltd monopolizing the entire Transmission network jurisdiction. Eastland Network Ltd (ENL) is one of the many distribution companies that provides electricity distribution services at Gisborne/East Cape and Wairoa District the most eastern urban areas of the North Island. A region with its popularity and recognition of its world stage award-winning wines and the famous summer visiting spot (Mahia peninsular) often attracts visitors during the once per year three days Harvest Hawkes Bay wine and food festival. The increasing numbers combined with other major daily commercial loads demand coupled with the aging lines infrastructure would strain the local distribution capability to meet the increasing load demand especially from Blacks Pad to Mahia node and thus would leave ENL with no option but to operate a standby 1 MW Diesel generator to provide load demand and ensure network stability (provide increase supply security avoid transmission charges from Transpower [2]). This identified issue has led to the interest of this study to investigate and offer remedial options to mitigate the problem at hand plus a surplus forecast capacity reserve. Past studies undertaken by Easthabor management services in 2003-2004 for the Wairoa district council and Tairāwhiti Development Taskforce have highlighted the above-mentioned issue with very brief mentioned on the potential investment of Hydro and other RE however no follow up studies was taken to address the summer spike demand [3]. Figure 1 depicts the ENL Jurisdiction [4].



Figure 1. ENL Jurisdiction [4].

The ENL distribution area covers a total population of 53,000 of which about 41,000 live in the urban Gisborne and 5,000 live in Wairoa urban area. Small pockets of settlements such as Mahia, Matawaim Ruatoria, Tokomaru Bay, Tolaga Bay and Te Karaka make up the remaining 7,000. Domestic Customers make up Seventy Five percent (75%) of the Inter-connection Points (ICPs) stated above which have become a feature of the Eastland Network. Table 1 outlines the trend of ICP numbers since 2004 through to 2017 [4].

Table 1. Inter Connection Points (ICPs) from 2004-2017

Year Ending	ICPs	Change	Domestic	Non-Domestic
31/03/2004	24849	(-327)	19115	5734
31/03/2005	24854	(+5)	19149	5705
31/03/2006	24871	(+17)	19228	5643
31/03/2007	24975	(+104)	19324	5651
31/03/2008	25196	(+221)	19513	5683
31/03/2009	25300	(+104)	19554	5746
31/03/2010	25432	(+132)	19691	5741
31/03/2011	25514	(+82)	19748	5766
31/03/2012	25567	(+53)	19850	5717
31/03/2013	25550	(-17)	19940	5610
31/03/2014	25353	(-197)	19298	6055
31/03/2015	25387	34	19310	6077
31/03/2016	25410	23	19331	6079
31/03/2017	25455	45	19438	6017

Energy demand and consumption based on historical data has displayed no variation (constant) or growth (<0%) for reasons relating to the climate pattern, change in load control strategy, and relocation of grid metering.

In pursuit for a sustainable power or energy systems within the Wairoa district especially over seasons and better management of the aging grid infrastructure especially the distributions lines, this study intends to investigate the viability of Solar Photovoltaic Distributed Generation and Storage system contribution to offer capacity demand for Mahia area during summer load spike resulting from the influx of visitors into Mahia Peninsular and also the growing demand from real estates and sewage management system for Mahia [4]. Offer a least cost remedy option to substitute the aging grid infrastructure (Power Lines, Voltage regulators, transformers etc.) to mitigate the network issues at hand and further substitute the existing non-environmental friendly 1MW diesel generator and aging Voltage Regulator. Most importantly, it is to support the global initiative to combat Climate Change through the utilization of Renewable energy Generation (Green Energy). The objectives of the study are as follows:

- i. To investigate the voltage drop trend along the 11kV distribution line from blacks Pad to Iririki
- ii. To assess the feasibility of developing a grid tied 1MW solar farm in Wairoa District (Mahia Suburb), New Zealand, to replace the diesel generator.

II. METHODOLOGY

The photovoltaic industry in New Zealand (NZ) for the last 10 years has been quiet with only few players in the market. However, based on a study by IT Power Ltd in 2009, the numbers of local distributors affiliating with overseas manufacturers have increased influencing the competitive panel prices to date [5].

The PV market in NZ has been slowly growing with most focus on small off-grid marketing until recently grid connected installations are boosting up for residential and commercial sectors. Grid connected PV system investment cost have dropped dramatically over the past 10 years for New Zealand as shown in Figure 2, reflecting the continuous price drop of solar panels. However, storage technologies such as batteries remains a burdensome cost. The overall PV cost depends on the system sizing and installation nature (i.e. rooftop/Ground mounted).

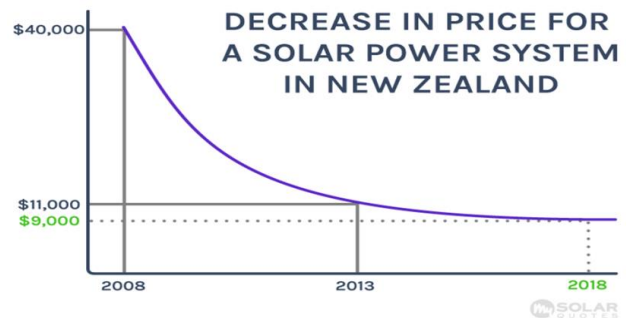

Figure 2 Cost of Solar PV in the last 10 years.

The International Renewable Agency in its updated global Solar database, 2017, recorded a 0.1% solar partition in the energy mix (see Figure 3) for NZ total installed Solar PV capacity [6].

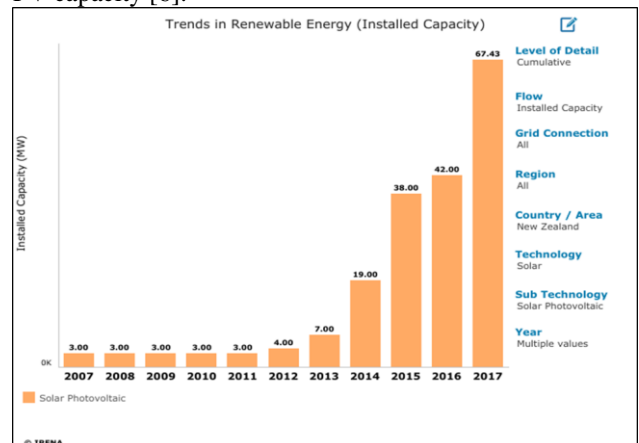

Figure 3. NZ PV Grid-connected Installed Capacity [6]

A. Data analysis and design approach for the local distribution network

This project utilises a combination of Power Factory (PF) and MATLAB to test and observe the voltage drops along the 11kV distribution network between nodes of interest. MATLAB is used mostly to analyse large

quantity of utility raw data that are nearly impossible to interpret via Microsoft excel and in some instances, a co-simulation framework is required based on MATLAB and PF. For instance, electricity spot prices from the year 2006 to 2017 and Mahia loads for a one-year period were simulated using MATLAB.

Simulation studies were conducted using the PF at different generation support scenarios to observe the voltage drop pattern along the distribution line from the starting of the 11kV feeder (Blackspad node) to Mahia load centres and beyond is crucial. This form the basis of investigating the feasibility of Solar PV system with back up storage to see whether it can offer the same generation support as the existing 1MW diesel generator and voltage regulator. Given the intermittent nature of PV and the potential impacts it could cause on the low voltage (LV) system, determining the maximum amount of generation capacity is mandatory so that the LV system can withstand without showing any voltage stability issue.

A combination of modified single diagram of the 33/11kV network from Wairoa to Blackspad and Mahia As shown in Figure 4 is sketched using PF by feeding in the data's (such as line voltage, impedance, distances, bus data and loads) obtained from the utility.

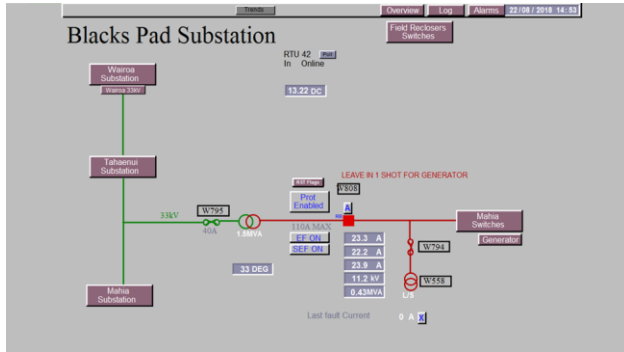

Figure 4. Blacks Pad Substation-Receiving end of 33 kV line.

Two different simulation scenarios approach were conducted using PF to observe the drops:

- i.) Run load analysis without voltage regulation support from Generator and Voltage regulator, and PV plus storage.
- ii.) Run load analysis under support generation supplied by PV and Storage.

Necessary line data (Distance, feeder type and size, impedance, reactance) are configured starting from Wairoa right through to the end of the line generalizing the model into one load centre only instead of the inclusion of the other two load centre (Mahunga and Kinikini) due to the load data provided is a combination of all loads after Blacks Pad.

B. PV Design Approach

This study proposed the PV power plant to be located within the Mahia load centre vicinity also known as the study area (Latitude: 39° 4'12.49"S, Longitude:

177°52'23.28"E) where the core network issue is centred around. There are handful of design tool or so-called PV modelling software, such as System Advisor Model (SAM), Homer, PVsys and Helioscope, are available in the market to model and simulate the PV power generation system performance. This investigation uses SAM and Helioscope interchangeably to design the 1MW PV farm. SAM primarily is used to simulate the economic analysis (Example: Capital cost) of the proposed PV System and storage, while Helioscope is utilised to model the electrical design overview of the system which SAM lacks. For this feasibility study, no manually design approach was utilised but rather feeding necessary PV system sizing data (Irradiance (GHI) data, required PV system capacity, Storage capacity and other relevant data) into the software's to model and simulate the desired PV system. Prior sizing the PV system, it is very important to understand the available solar resource in the within the location of installation and know the typical load profile of the customers (households). Obtaining such information will allow the system to be size accordingly to sufficiently meet the daily demand during summer. Basic PV peak power output can be calculated using equations (1) and (2).

$$PPV (kWp) = E_{load}/P_{output} \quad (1)$$

where, E_{Load} : - Summer month's average load and P_{output} - the power production from 1kWp of PV-modules during a summer months in kWh/month, kWp

$$P_{DC} = E/(PSH \times 30 \times K_d) \quad (2)$$

where, E - Load (kWh/month); PSH- Peak Sun hours; K_d - Derating Factor (System losses and efficiency)

C. Storage Sizing

Once the load profile is known, the final energy demand design can then be calculated. This also applies to the selection and sizing of the Battery inverter. In both DC and AC bus systems, the selection and sizing of the battery bank total energy demand is determined by considering all energy demand requirements and losses (system) up to the battery connection. Thus, the total designed energy demand from the DC bus (the battery (Wh)) can be calculated by equation (3).

$$E_{TOT} = E_{DC} + [E_{ac}/(\eta_{inv} \times \eta_{cable})] \quad (3)$$

where, E_{TOT} - Total design daily energy demand from the DC bus – the battery (in Wh); E_{DC} - Daily design DC energy demand (in Wh); E_{ac} - Daily design AC energy demand; η_{inv} - Average energy efficiency of the battery inverter when supplying the AC design energy demand and η_{cable} - cable efficiency between battery and AC switchboard.

Thus, the Battery Capacity (Ah) and Capacity for Autonomy (Ah) can be determined by equations (4) and (5).

$$\text{Daily Battery capacity (Ah)} = E_{TOT}/(V_{dc} \times DOD_{\text{daily}}) \quad (4)$$

$$\text{Autonomy Battery capacity (Ah)} = (E_{TOT}/(V_{dc})) \times (T_{\text{aut}}/(DOD_{\text{max}})) \quad (5)$$

where,

E_{TOT} - Total design daily energy demand at the battery (in Wh)

V_{dc} - System Voltage (in V)

DOD_{daily} - Maximum daily Depth of Discharge

DOD_{max} - Maximum allowable depth of discharge

T_{aut} - Days if autonomy

The 2017 load data shows that the load was more than 1000kW for 930 minutes or approximately 15.5 hours. This suggests that the generator only needs to top-up the load for this amount of time. Furthermore, loads were most of the time under 300kW, therefore this would indicate a base load generator supply of 300kW would get good utilisation for running and selling power most of the time. Considering times when load is over 700kW, an equivalent of 8250 minutes (137 hrs) is perhaps a value where the Voltage Regulator (VR) at Mahia is fixing the voltage at the lower loads it would not be needed. This suggests that a battery supporting load for 137 hours a year will be useful. The average loads at 700kW over a given month (January 2017), equates to 130.7 hrs of run time in a month or 4.35 hours (130.7hrs / 30days) run time per day.

Based on the typical observation of the generator running at 300kW most times throughout the past years and the times when the battery could best suit supplying the load in replacement of the VR, a typical battery bank of 400kW capacity and 4 hours run time around 32 to 34 days per year is recommended as storage capacity for the PV system.

Due to limitation of space, the paper only shows the results of the voltage profiles.

III. RESULTS

A. Site Investigation Findings

To better understand the core drivers triggering the feasibility study for the grid connected Solar PV system, thorough discussion with the key stakeholders is vital. Most discussion are done through formal in person dialogue with the Eastland Network Ltd team in Gisborne on a one-time occasion to share with them the purpose and core objectives of conducting this study and also further understand the nature of the challenges they are experiencing within their distribution network. Table 2, basically summarises the three main shortfalls ENL is currently confronted by within their network infrastructure and possible solutions.

Table 2. Summary of Key Network Issues encountered by ENL [4]

Network Issues	Description	Possible solution
Line Voltage Drop	Line Voltage drop due to the long-distance span from the source to the load (Blackspads substation-Mahia load centre)	-Install much bigger wire (lines). Between source and load as highlighted in ENL Asset Management Plan 2018-2030. -Move Source node (i.e. Blackspads near load centre (i.e. Mahia Beach) - Install Distributed Generator (Solar, Wind etc), Capacitor Bank and Storage
Holiday Demand	Occasional demanding load around Mahia beach over summer and Easter plus increase load due to developments such as real estate.	Generator options plus storage apart from existing diesel generator.
Aging infrastructure	-Faulty aging poles that would rough take 2 days to repair/replace -Aging lines resulting to line losses along the network.	Pole and Lines replacement

A.1. Voltage Drops

Theoretically, as electricity travel either downstream or upstream from the source to the receiver end, the voltage level will begin to decrease. Voltage drop along the line depends on several factors such as the distance between the two points and the size of the cable (line).

As depicted in Figure 5, 33Kv supply is stepped down at Mahia substation (Blacks Pad) to 11kV to be able to distribute the low voltage supply to the consumers in Mahunga, Mahia and Kinikini area.

Based on ENLs observations, the drop in the line voltage occurs between Blacks Pad, Mahia beach and the end of the distribution line. The drop is greatly impacted by the long distance the 11kV must travel over a single line until it supplies the requested load in Mahia. It is noted that from Blacks Pad at 11.2kV, the voltage drops around 5% of the line capacity, thus at Mahia where the

VR and generator is located, a 10.6 kV is recorded. The VR would then intervene to fix the voltage level to bring it back to 11kV to stay reference with the grid again to be able to supply the loads at the end of the line. Turning the Diesel Generator has to provide the required kW only to ensure no over voltage issue which can create more losses down the line. The voltage at the end of the line would then drop again. When needed the diesel generator would step in to supply additional capacity from the grid to meet the load demand.

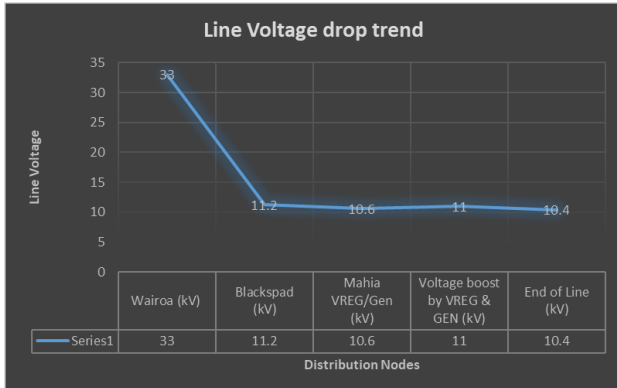

Figure 5 Line Voltage drop trend summary [4].

A.2. Holiday Demand

Summer and Easter holiday load peaks growth has obviously been a norm within the ENL network jurisdiction associated with the tourism and holiday settlements. According to the Tairawhiti Energy Assessment conducted by Eastland Harbour Management Services in 2004, in summer, the number of visitors visiting the famous Mahia Peninsula can spike up to 3000 to 5000 people on top of the under 1000 (872 heads) population in Mahia [4]. The 2016 launched Mahia Rocket lab also is a potential driver to increase tourism activity in Mahia. Figure 6, represent the annual load summary (2015 and 2016) around Mahia area where it is noticeable that the trend over the summer months (December, January and February) energy consumption are high.

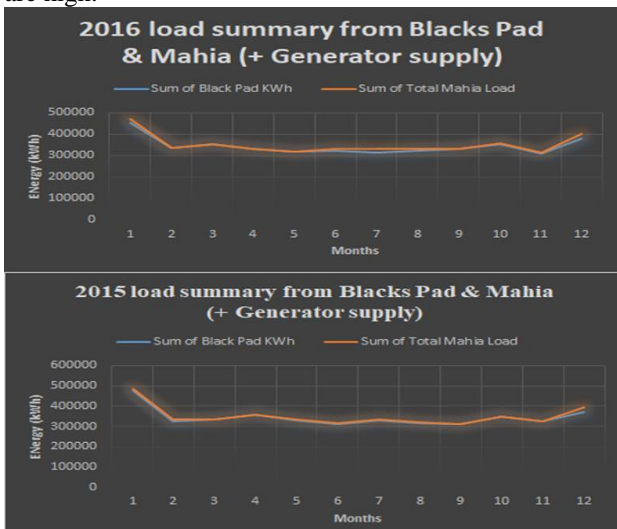

Figure 6. Mahia Load Summary 2015 and 2016

A.3. Aging Infrastructure

Aging infrastructure includes but not limited to feeders, poles and others. Distribution feeders have also been a contributing factor to the Voltage drop long the Blacks Pad-Mahia distribution network leading to the reduction in the line efficiency. Eastland Network as part of their strategic plans in terms of security reinforcement due to growth, the plan is to expand and upgrade the 11 kV feeders. At this stage, the ENL AMP 2018-2030 does not indicate any plans to upgrade the 11kV feeders to Mahia. Hence, feeder upgrade to Mahia as a mitigating option for voltage drops would seem to be a very expensive exercise. Table 3, provides an indication of how budget is needed to upgrade or implement new feeders in the future from Blacks Pad to Mahia.

Table 3. Cost breakdown of Line and Cable upgrades [4]

Item	Distance (km)	Cost per km (\$)	Total cost (\$)
Line	1.0	110,000	110,000
Cable	0.5	220,000	110,000

B. Low Voltage distribution network simulation under various generation support and load

Through the collation and validation of the data (years 2006 – June 2018) coupled with the aim of investigating the voltage drop from Blacks Pad to Mahia, the simulation test using Power Factory (PF) was done based on the worst case scenario when the load is high at the Mahia end assuming the summer and Easter holiday demand as clear depicted in Figure 7.

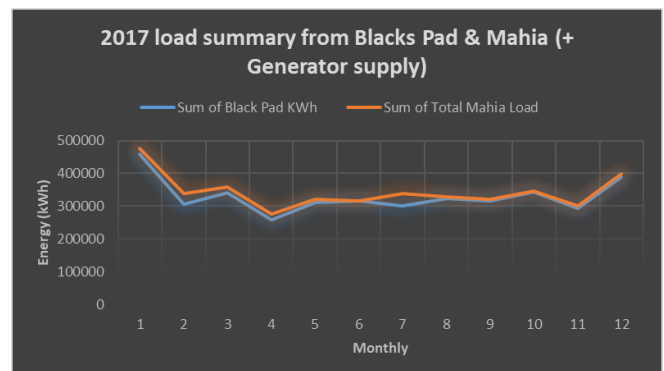

Figure 7. 2017 load summary from Blacks Pad and Mahia

Load data analysis shows the below trend in terms of the loads entering from Wairoa into Blacks Pad and loads consumed at Mahia load centre plus the generator kilowatt hours supplied and the corresponding load duration curve at various kilowatt outputs. For instance, Figure 8 shows annual energy (kWh) recorded at Blacks Pad and Mahia (inclusive of generator kWh) and the annual load duration curve, 2016 and 2017.

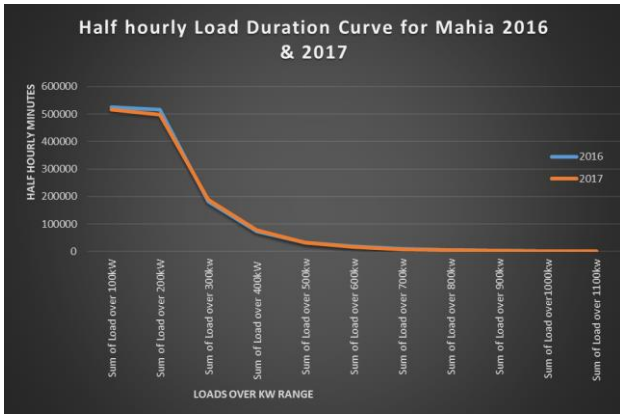

Figure 8. 2016 - 2017 Load Duration Curve

With the clear understanding of the load pattern in Mahia, the voltage drop test simulation considers the worst case scenario when the load is high during summer load demand.

Case 1:

The objective of conducting the model simulation to test and observe the voltage drop behaviour from the beginning of the 11kV line at Blacks Pad through to Mahia and the end of the distribution line anticipating a drop. Simulation outcome is as shown in Figure 9. Running the load flow calculation from blacks Pads initial 11kV, the voltage at the Voltage Regulator is recorded at 10.9kV (0.99pu) and a further drop of 10.4kV, which obviously signifies the need for additional generation support to meet the demanding load in summer. The 10.4 kV is way below the minimum voltage drop standard of 5% of line capacity.

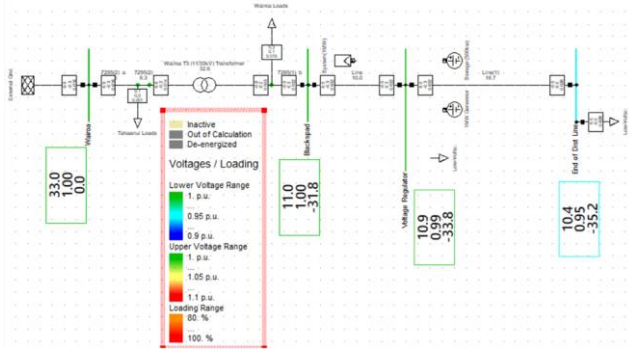

Figure 9. Voltage Profiles with no support

Case 2: Full Support but Replaced the Diesel Generator with PV and Storage.

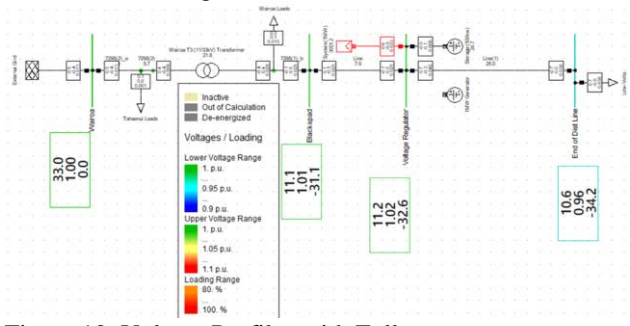

Figure 10. Voltage Profiles with Full support

Figure 10 depicts similar drop trend at each nodes, with the end of line voltage drop recorded at 10.6 or 0.96 pu. Thus, it has achieved similar results but it is more environmental friendly since there is no diesel generator is needed.

IV. CONCLUSION

With the core objective of determining the potential for Solar PV to replace the existing 1MW diesel generator that is currently mitigating the voltage drops and summer load spike in Mahia, findings and simulation results put Solar PV and Storage technically feasible. The voltage drop test outcome proof that PV is equally capable of offering the same support as the diesel generator. Though the current load requirements in Mahia would suggest a 300-500kW PV plant, a 1MW is recommended to basically supply the needed demand and also gather for future growth such as real estate development in Mahia. The economics of Solar PV looks promising though the production price seems double to the cost of Diesel. However, with the Governments commitments to fight against Climate change through the use of renewable energy sources, Solar is clearly the substituting option for diesel generator. Subject to funding availability to implement the PV system, it is recommended that an in-depth design of the Solar PV is carried out..

ACKNOWLEDGMENT

Sincere and massive thank you to the Eastland Network Ltd (ENL) team in Gisborne, especially Mr. Murray Carman and Mishu Chakma for their swift respond to offer their assistance during the two days visit to Gisborne to obtain the data.

REFERENCES

- [1] M. I. Henderson, D. Novosel, and M. L. Crow, "Electric Power Grid Modernization Trends, Challenges, and Opportunities," *IEEE Power and Energy*, November 2017.
- [2] East Harbour Management Ltd. (2003, June). Energy Supply Scoping Study to Wairoa. Retrieved from <http://www.eastharbour.co.nz/assets/pdfs/Wairoa-Energy-Supply-Scoping-Study-to-Wairoa-DCJune2003.pdf>.
- [3] Tairāwhiti Regional Energy Assessment (Rep.). 20 Dec. 2004.
- [4] Asset Management Plan 2018-2028 (Rep.) 1 April 2018.
- [5] Transpower New Zealand Limited. (2017, December 11). Solar PV in New Zealand. Retrieved from <https://www.transpower.co.nz/sites/default/files/plain-page/attachments/Solar%20PV%20in%20New%20Zealand.pdf>, 11 December 2017.
- [6] Accelerating the global energy transformation. International Renewable Energy Agency (IRENA), 2017.